



US00D754207S

**(12) United States Design Patent
Lamparelli****(10) Patent No.: US D754,207 S****(45) Date of Patent: ** Apr. 19, 2016****(54) PROPULSION CONTROL SYSTEM FOR SHIP
WITH A DISPLAY****(71) Applicant: Wartsila Finland Oy, Vaasa (FI)****(72) Inventor: Davide Lamparelli, Fitjar (NO)****(73) Assignee: Wartsila Finland Oy, Vaasa (FI)****(**) Term: 15 Years****(21) Appl. No.: 29/536,613****(22) Filed: Aug. 18, 2015****Related U.S. Application Data****(62) Division of application No. 29/454,667, filed on May 13, 2013, now Pat. No. Des. 742,418.****(30) Foreign Application Priority Data**

Nov. 13, 2012 (EM) 002134809

Nov. 13, 2012 (EM) 002135004

Nov. 13, 2012 (EM) 002135038

(51) LOC (10) Cl. 15-01**(52) U.S. Cl.**
USPC **D15/4; D12/317****(58) Field of Classification Search**USPC D15/5, 4; D12/300, 301, 303–315, 317,
D12/174, 178–180; D13/134, 168, 169,
D13/173; D10/49; 74/469, 473.1–473.12,
74/473.19, 473.2, 590 B, 491; 440/84–87,
440/98, 111, 112, 113
CPC B63H 21/21; B63H 21/213; B63H 25/00;
B63H 2025/026; B63H 25/46; Y10T
137/87064; Y10T 74/20732; Y10T 74/20612;
Y10T 137/87072; Y10T 74/20636; Y10T
74/20201; F02D 11/106; F02D 41/2464;
H01H 2217/04; H01H 2221/008; H01H
25/008

See application file for complete search history.

(56) References Cited

U.S. PATENT DOCUMENTS

6,538,217 B1 * 3/2003 Eriksen B63H 21/213
114/144 RE
D573,936 S 7/2008 Jin
D581,855 S 12/2008 Arol
D593,481 S * 6/2009 Kobelt D12/317
D663,253 S 7/2012 Bondesson
D663,254 S 7/2012 Bondesson
8,406,944 B2 3/2013 Garon et al.
D689,423 S 9/2013 Park et al.
D689,424 S 9/2013 Park et al.
D710,781 S 8/2014 Park et al.
8,925,414 B1 1/2015 Park et al.
8,930,050 B2 1/2015 Garon et al.
2007/0249244 A1 10/2007 Watanabe et al.

* cited by examiner

Primary Examiner — T. Chase Nelson*Assistant Examiner* — Ania Aman**(74) Attorney, Agent, or Firm** — Muncy, Geissler, Olds & Lowe, P.C.**(57) CLAIM**

The ornamental design for a propulsion control system for ship with a display, as shown and described.

DESCRIPTIONFIG. 1 is a perspective view of a propulsion control system for ship with a display with a screen display on the left;
FIG. 2 is a left side view thereof;
FIG. 3 is a right side view thereof;
FIG. 4 is a top plan view thereof;
FIG. 5 is a front elevational view thereof;
FIG. 6 is a rear elevational view thereof; and,
FIG. 7 is a perspective view thereof with the screen display activated.

The broken line showing is for the purpose of illustrating portions of the propulsion control system for a ship with a display which form no part of the claimed design.

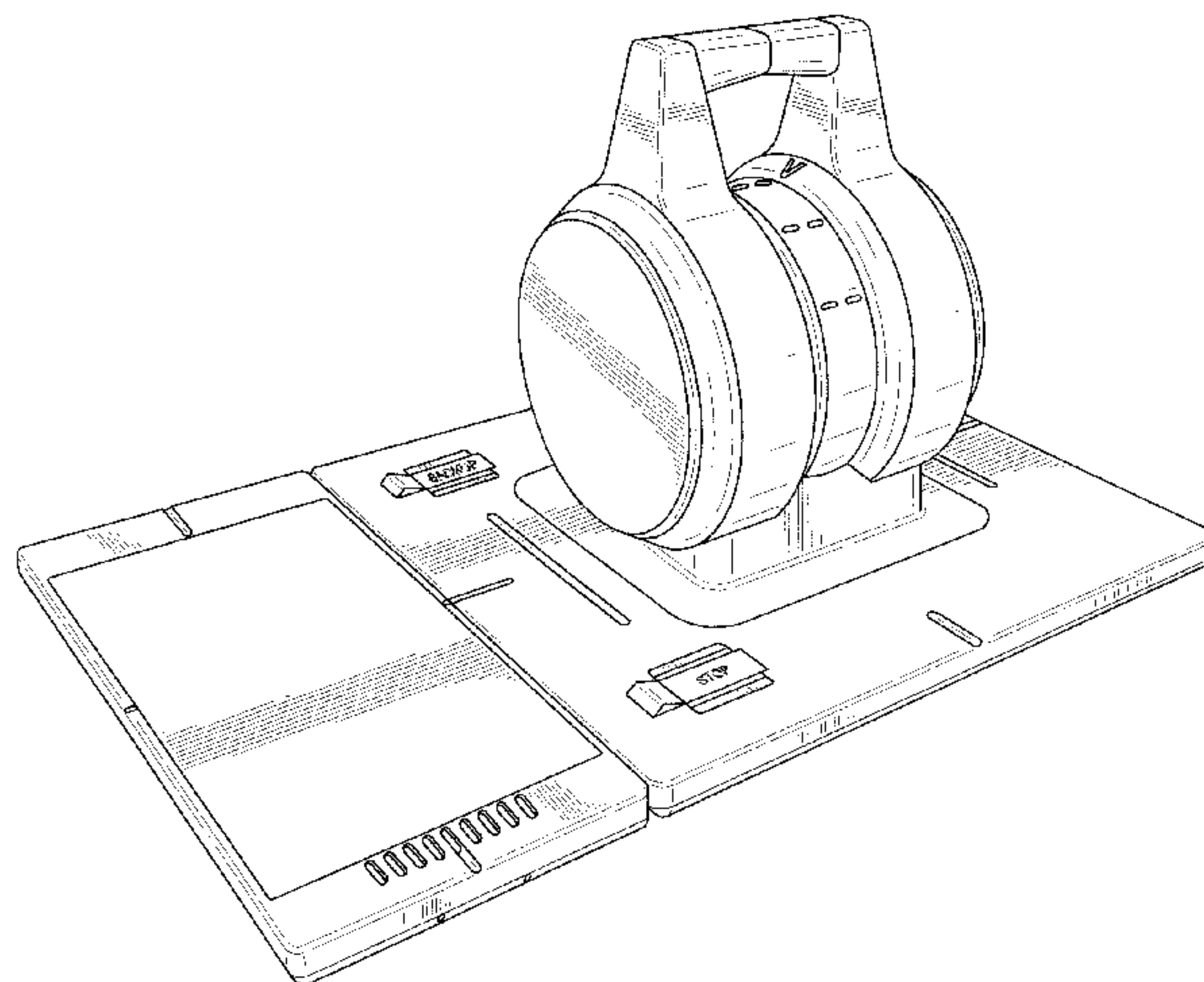
1 Claim, 7 Drawing Sheets

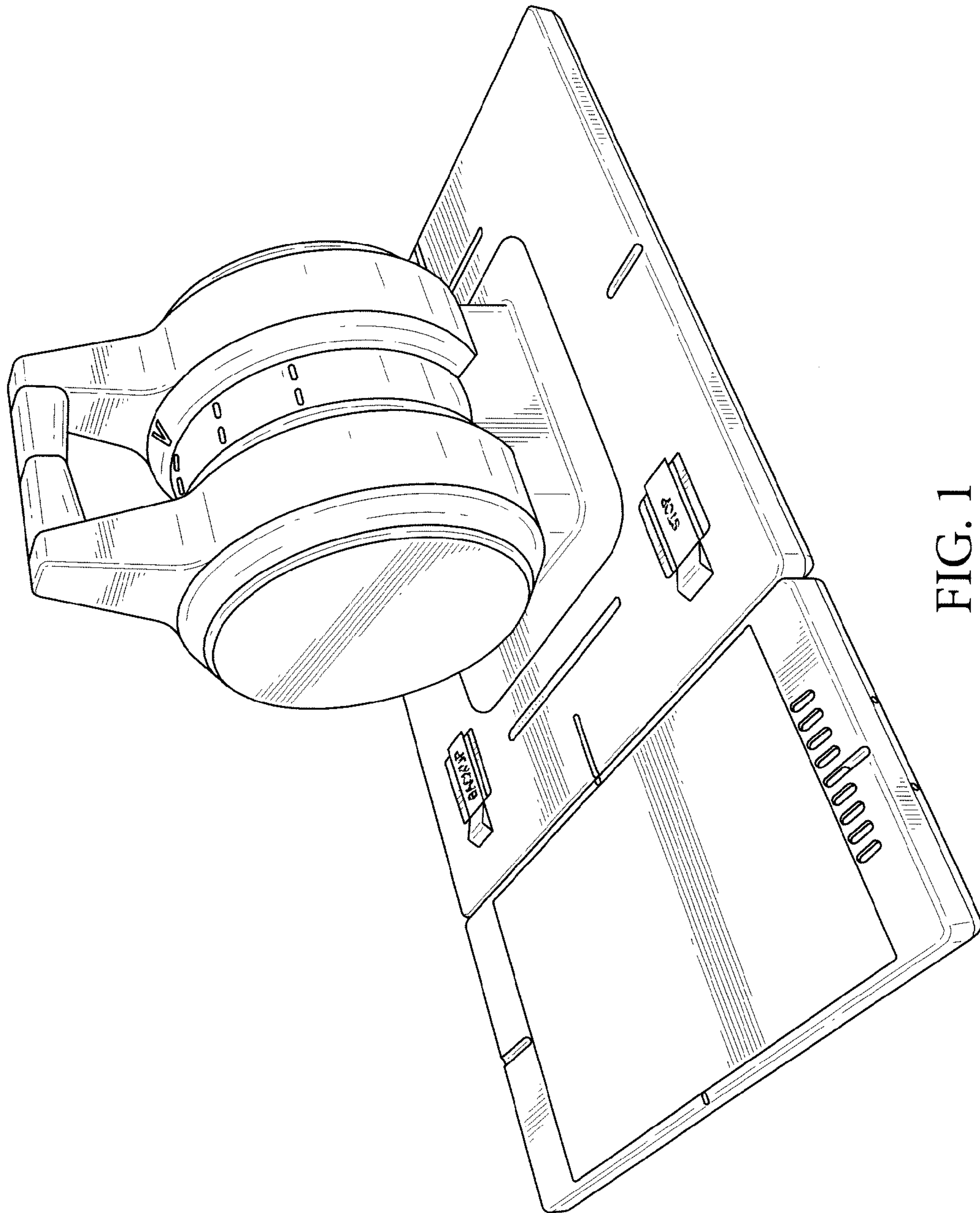

FIG. 1

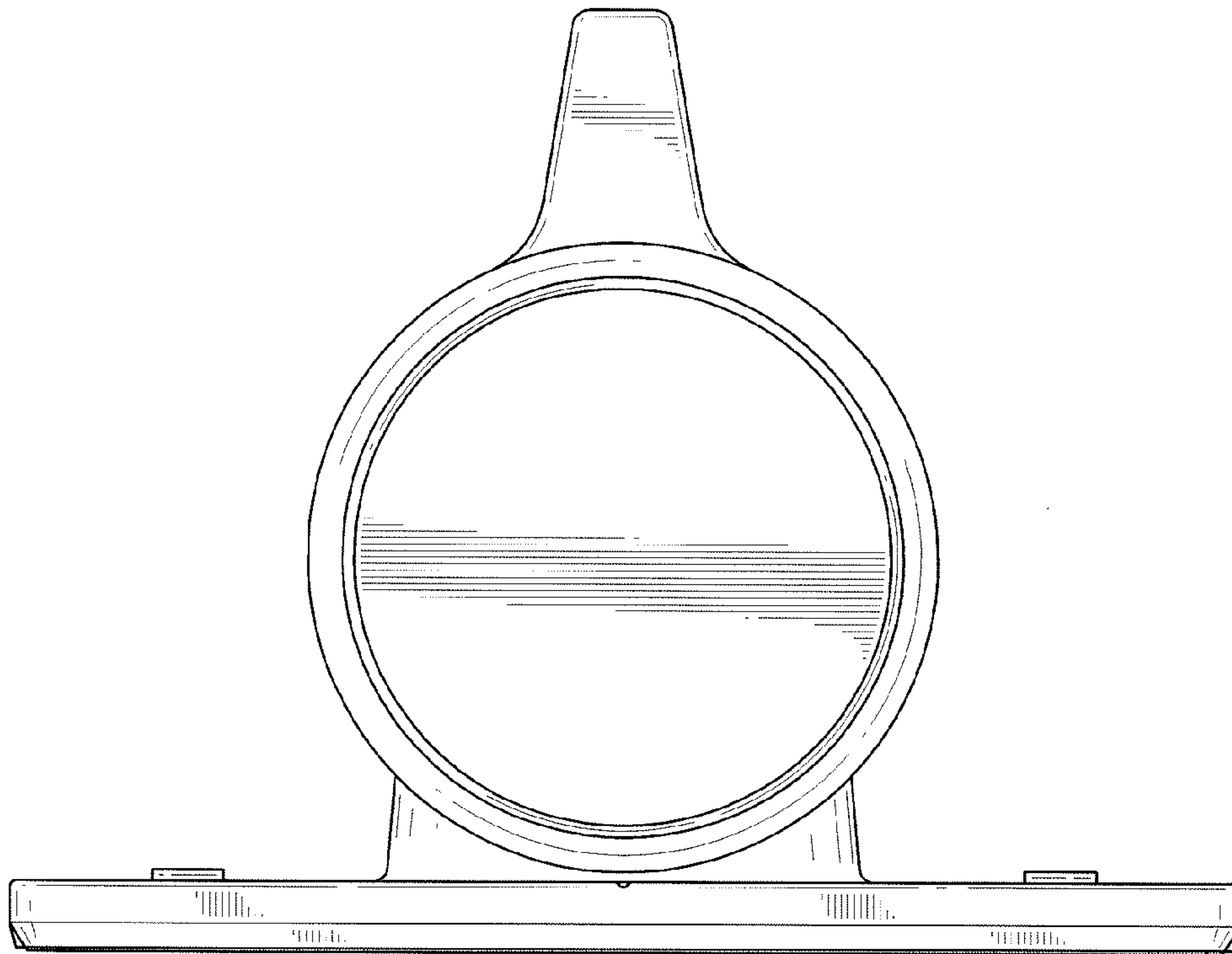

FIG. 2

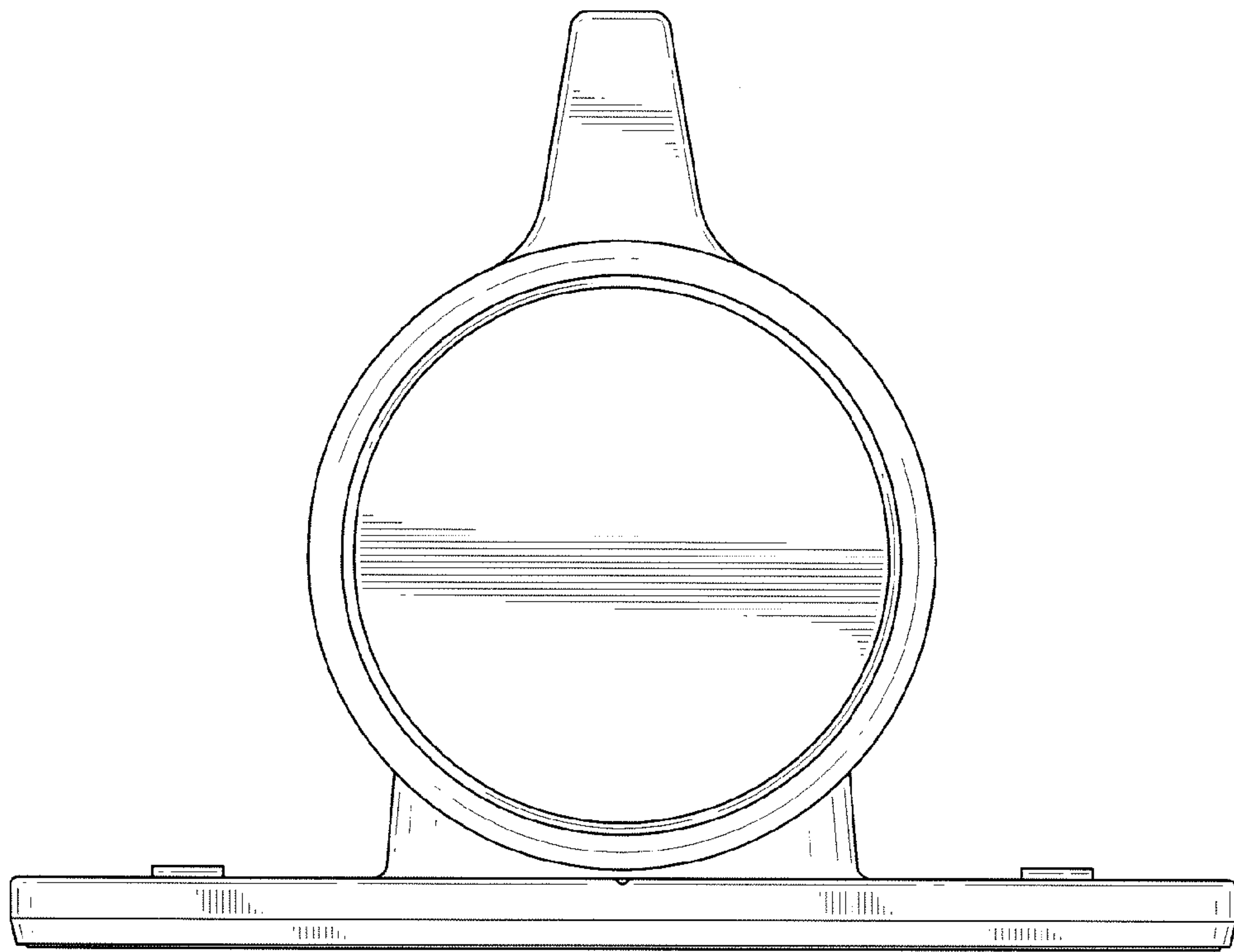

FIG. 3

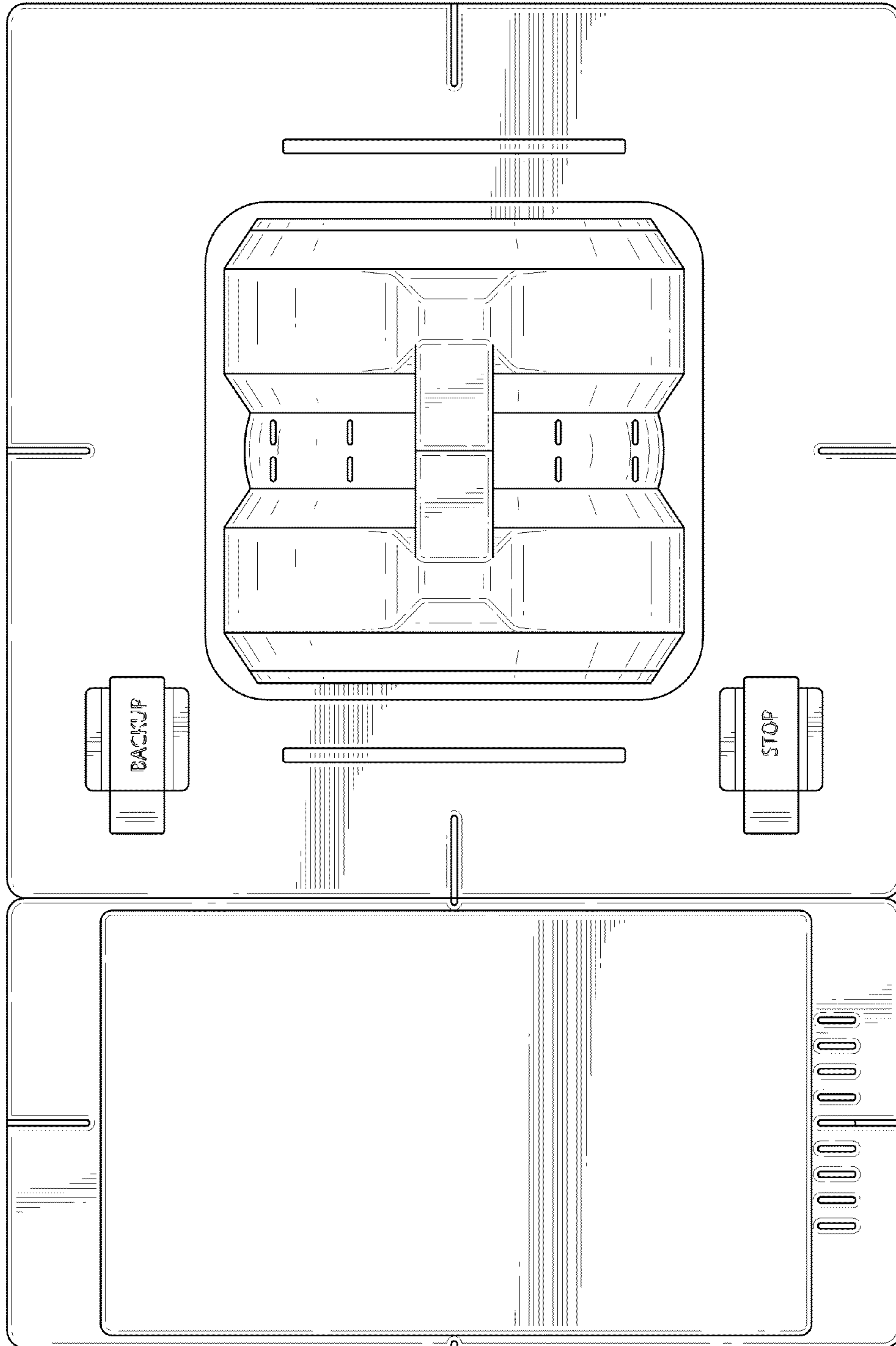

FIG.4

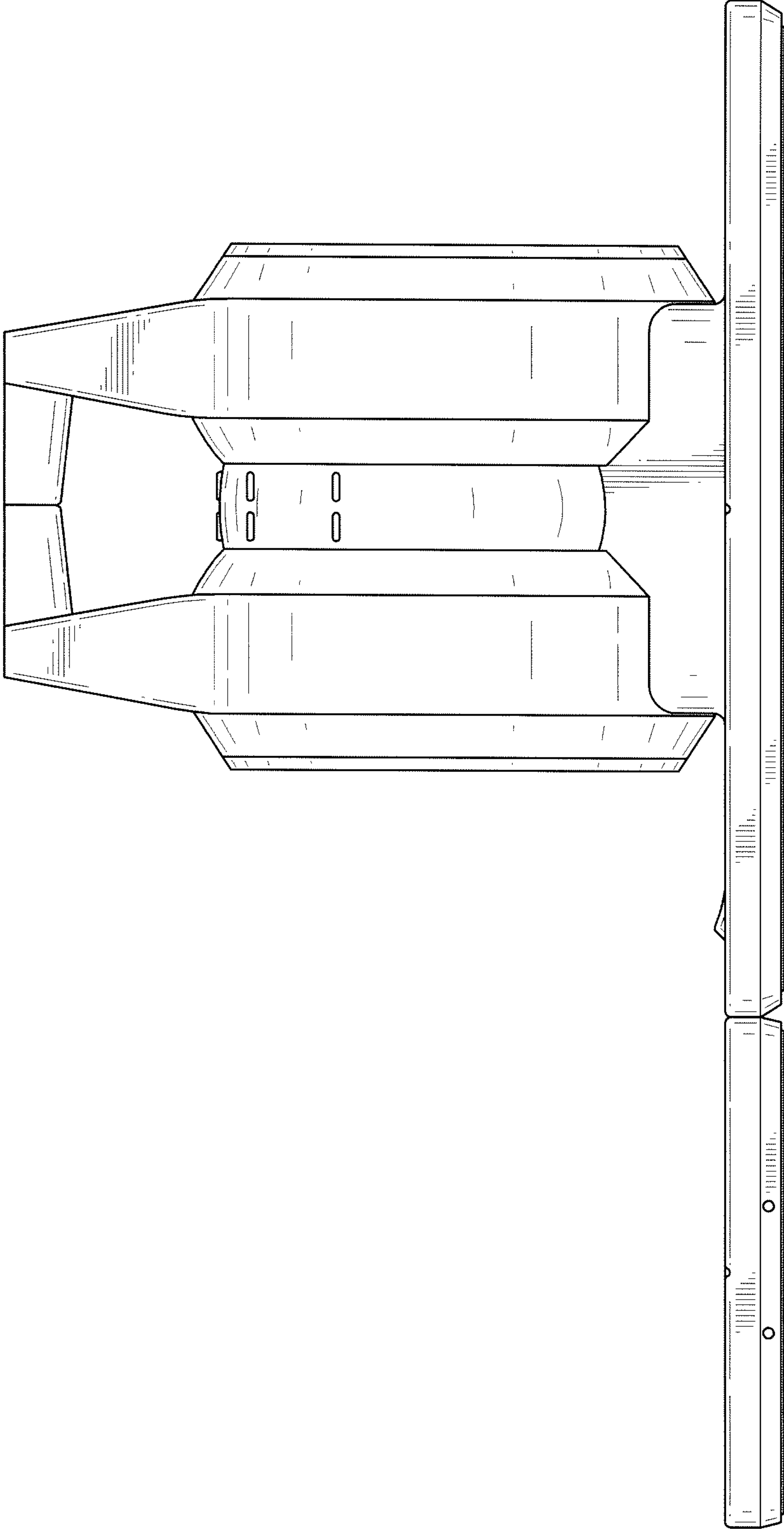

FIG. 5

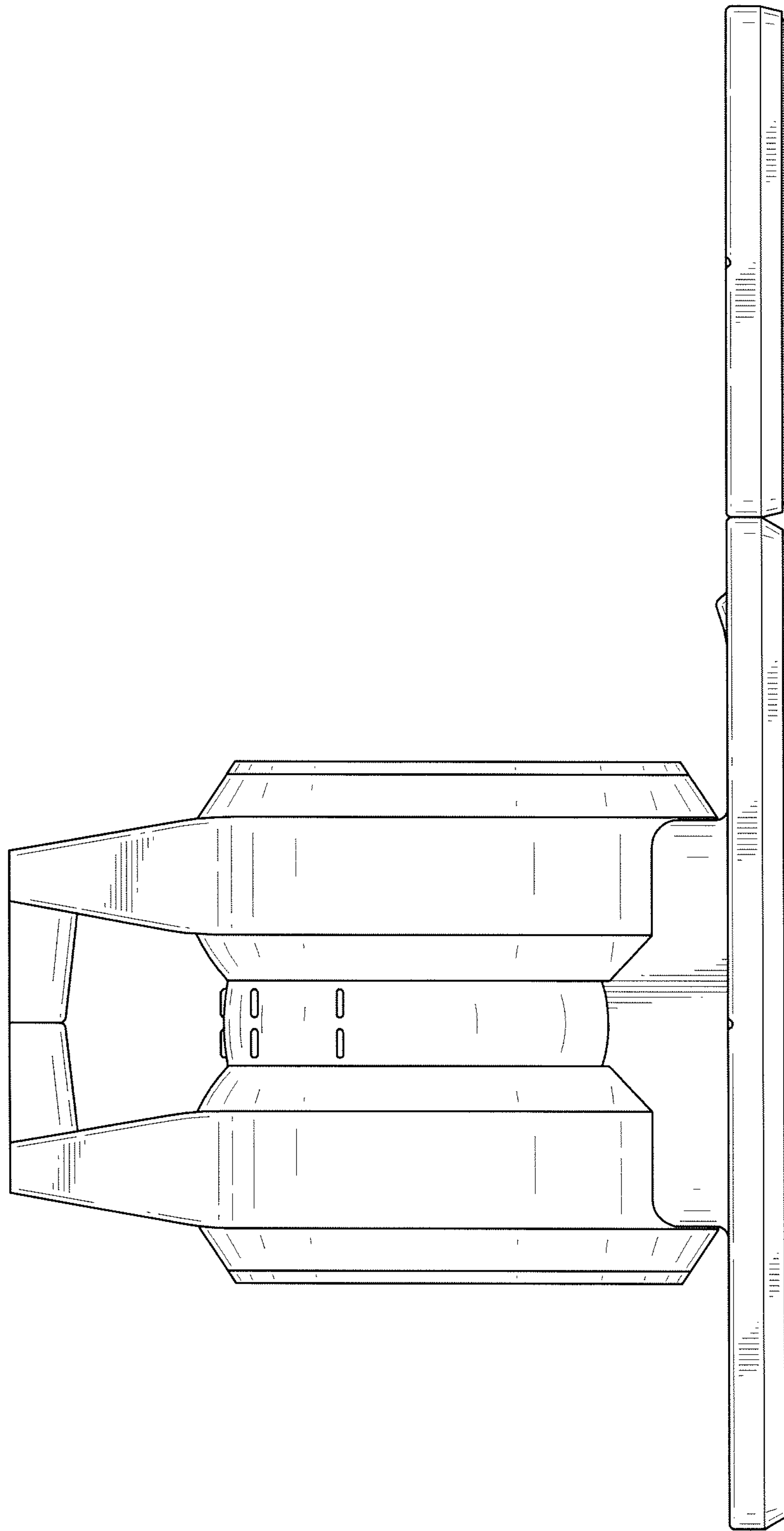

FIG. 6

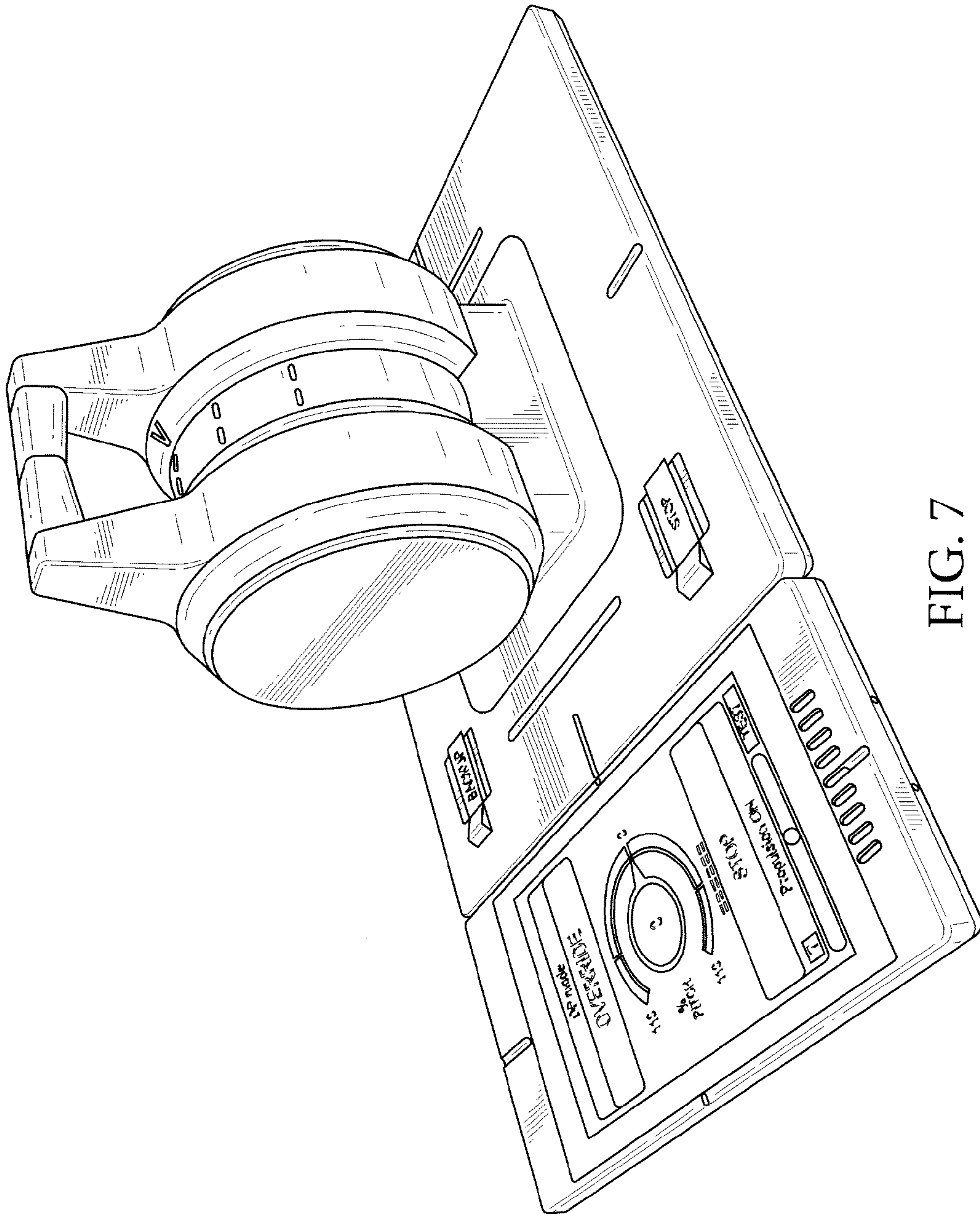

FIG. 7