

US00D754053S

(12) **United States Design Patent**
Robertson

(10) **Patent No.:** **US D754,053 S**

(45) **Date of Patent:** **** Apr. 19, 2016**

(54) **WING ROOT LEADING EDGE EXTENSION**

(71) Applicant: **Paul E. Robertson**, Arlington, WA (US)

(72) Inventor: **Paul E. Robertson**, Arlington, WA (US)

(73) Assignee: **Aeronautical Testing Service, Inc.**,
Arlington, WA (US)

(**) Term: **14 Years**

(21) Appl. No.: **29/482,564**

(22) Filed: **Feb. 19, 2014**

(51) **LOC (10) Cl.** **12-07**

(52) **U.S. Cl.**
USPC **D12/345**

(58) **Field of Classification Search**
USPC D12/345
CPC B64C 1/26; B64C 3/00; B64C 3/14;
B64C 3/24; B64C 2003/146; B64C 5/00;
B64C 5/06; B64C 7/00; B64C 7/02; B64C
21/00; B64C 21/06; B64C 21/08; B64C
23/00; B64C 23/06
See application file for complete search history.

(56) **References Cited**

U.S. PATENT DOCUMENTS

D182,014	S	*	2/1958	Brownell	D12/345
2,927,749	A	*	3/1960	Brownell	244/45 R
3,693,913	A	*	9/1972	Barland et al.	244/130
3,968,946	A	*	7/1976	Cole	244/214
4,569,494	A	*	2/1986	Sakata	244/199.1
D287,962	S	*	1/1987	Brechtbill et al.	D12/345
5,314,142	A	*	5/1994	Rao et al.	244/35 A
6,073,889	A	*	6/2000	Dees et al.	244/213
6,152,404	A	*	11/2000	Flaig et al.	244/199.1
7,510,144	B2	*	3/2009	Ambite Iglesias et al.	244/87
8,128,035	B2	*	3/2012	Malachowski et al.	244/199.4

8,177,170	B2	*	5/2012	Fol et al.	244/200
2010/0019080	A1	*	1/2010	Schweighart et al.	244/49
2012/0187252	A1	*	7/2012	Gerber	244/209

* cited by examiner

Primary Examiner — Martie K Holtje

(74) *Attorney, Agent, or Firm* — Seed IP Law Group PLLC

(57) **CLAIM**

The ornamental design for a wing root leading edge extension, as shown and described.

DESCRIPTION

FIG. 1 is a front left side isometric view of a wing root leading edge extension for a left wing of an aircraft showing my new design;

FIG. 2 is a top plan view of the wing root leading edge extension of FIG. 1;

FIG. 3 is a bottom plan view thereof;

FIG. 4 is a front elevational view thereof;

FIG. 5 is a rear elevational view thereof;

FIG. 6 is a left side elevational view thereof;

FIG. 7 is a right side elevational view thereof; and

FIG. 8 is a front right side isometric view of a wing root leading edge extension for a right wing of an aircraft showing my new design;

FIG. 9 is a top plan view of the wing root leading edge extension of FIG. 8;

FIG. 10 is a bottom plan view of FIG. 8;

FIG. 11 is a front elevational view of FIG. 8;

FIG. 12 is a rear elevational view of FIG. 8;

FIG. 13 is a right side elevational view of FIG. 8; and,

FIG. 14 is a left side elevational view of FIG. 8.

The broken lines on the peripheral edge of the interior surface of the wing root leading edge extension represent a boundary, the area within which forms no part of the claimed design.

1 Claim, 10 Drawing Sheets

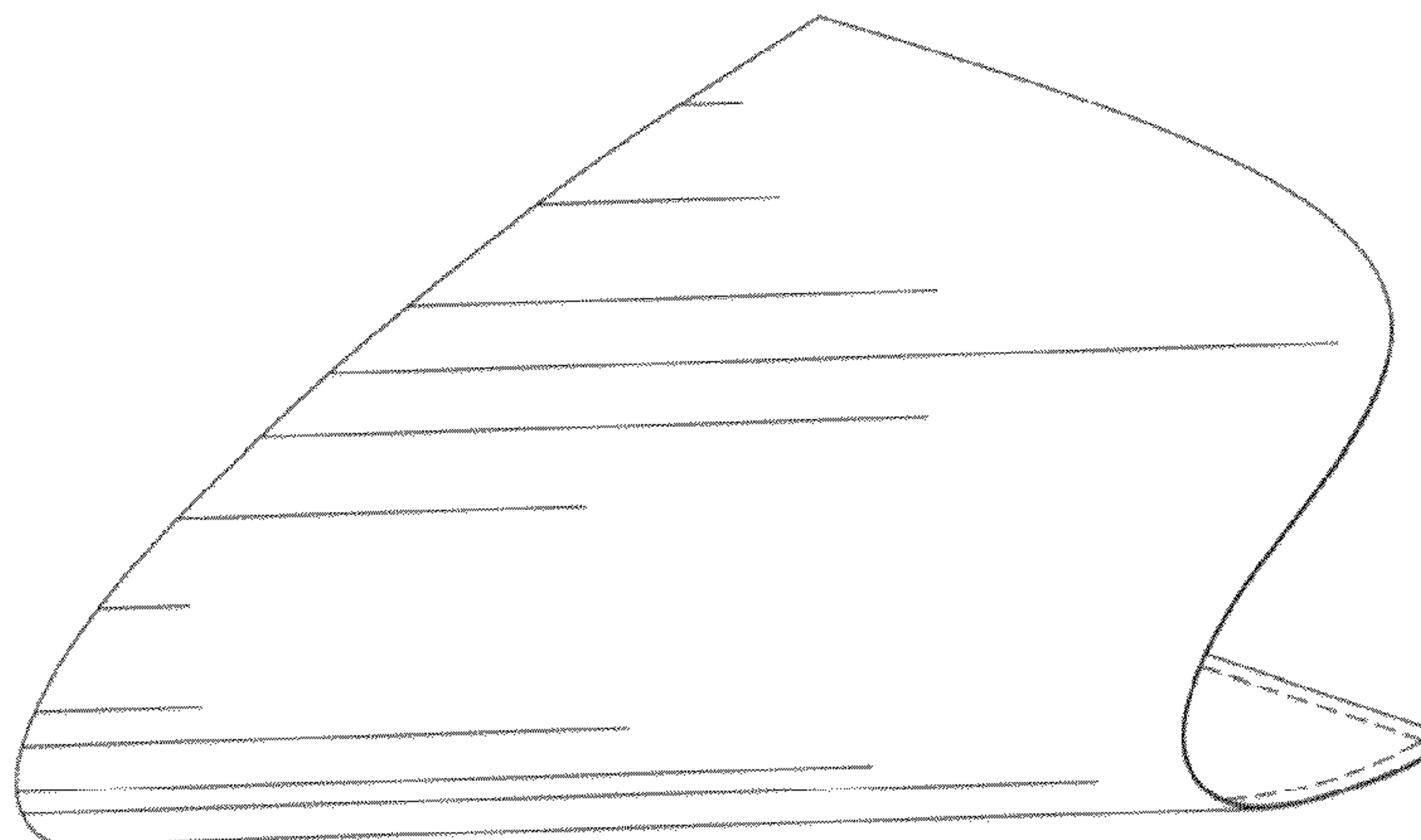

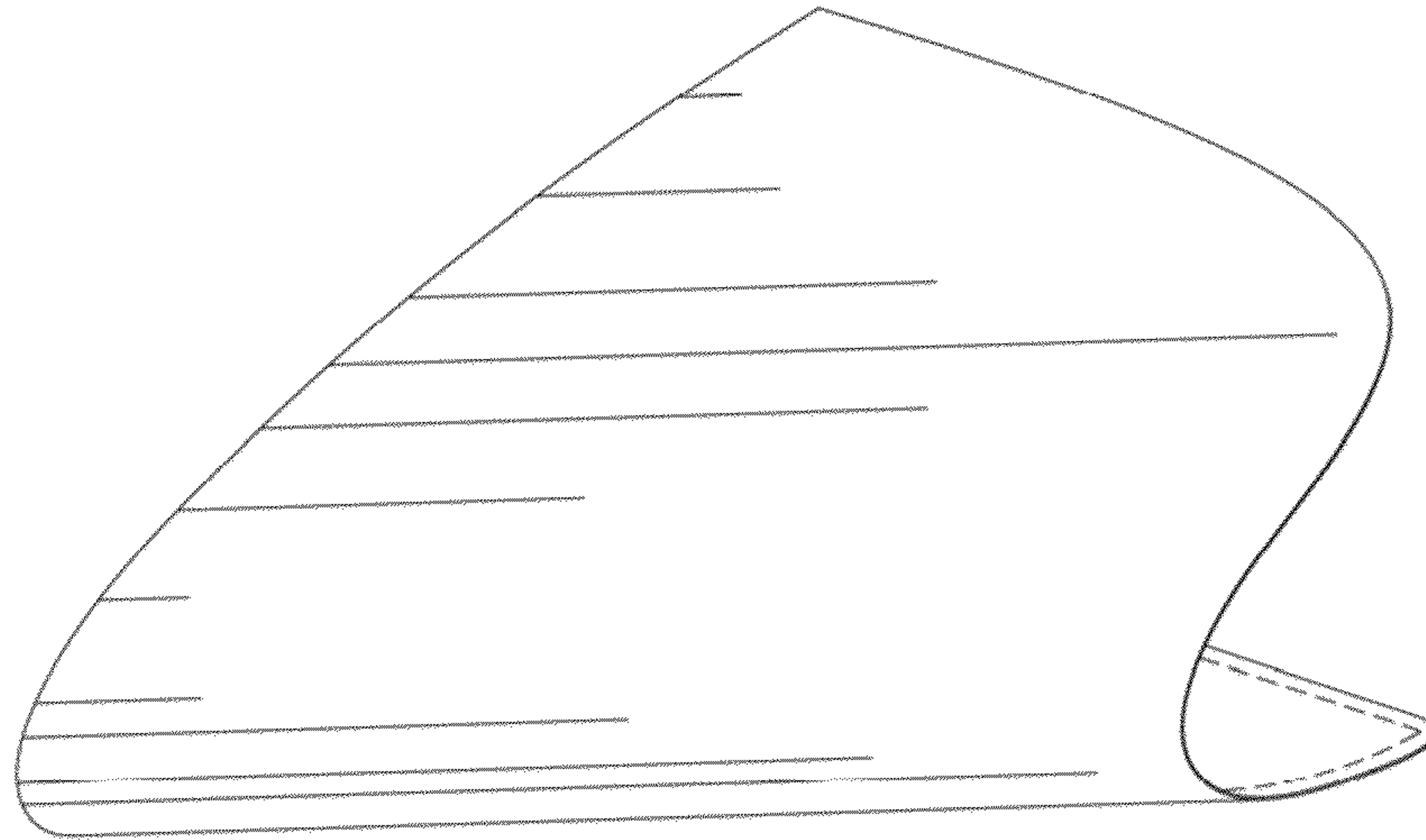

FIG. 1

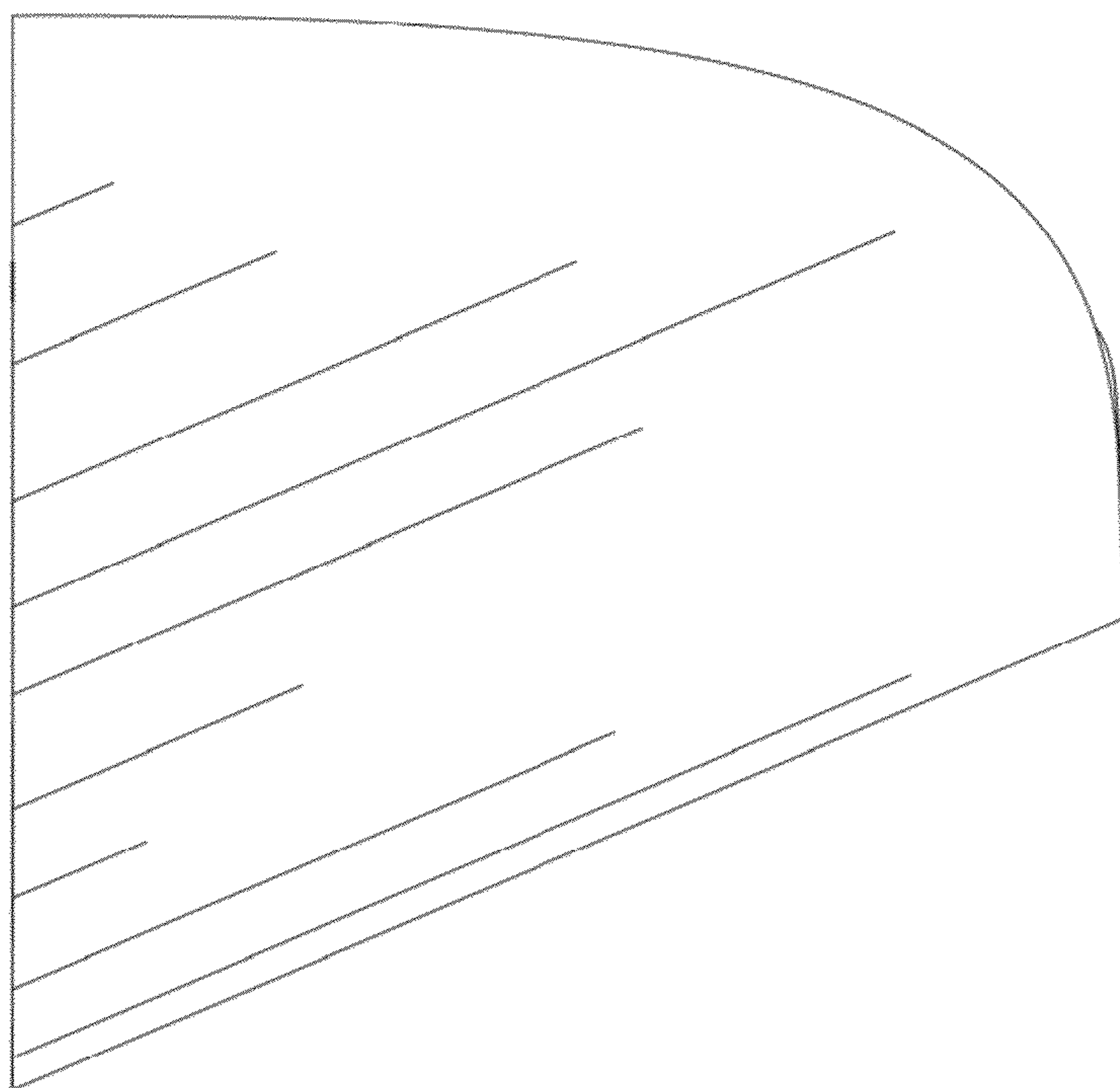

FIG. 2

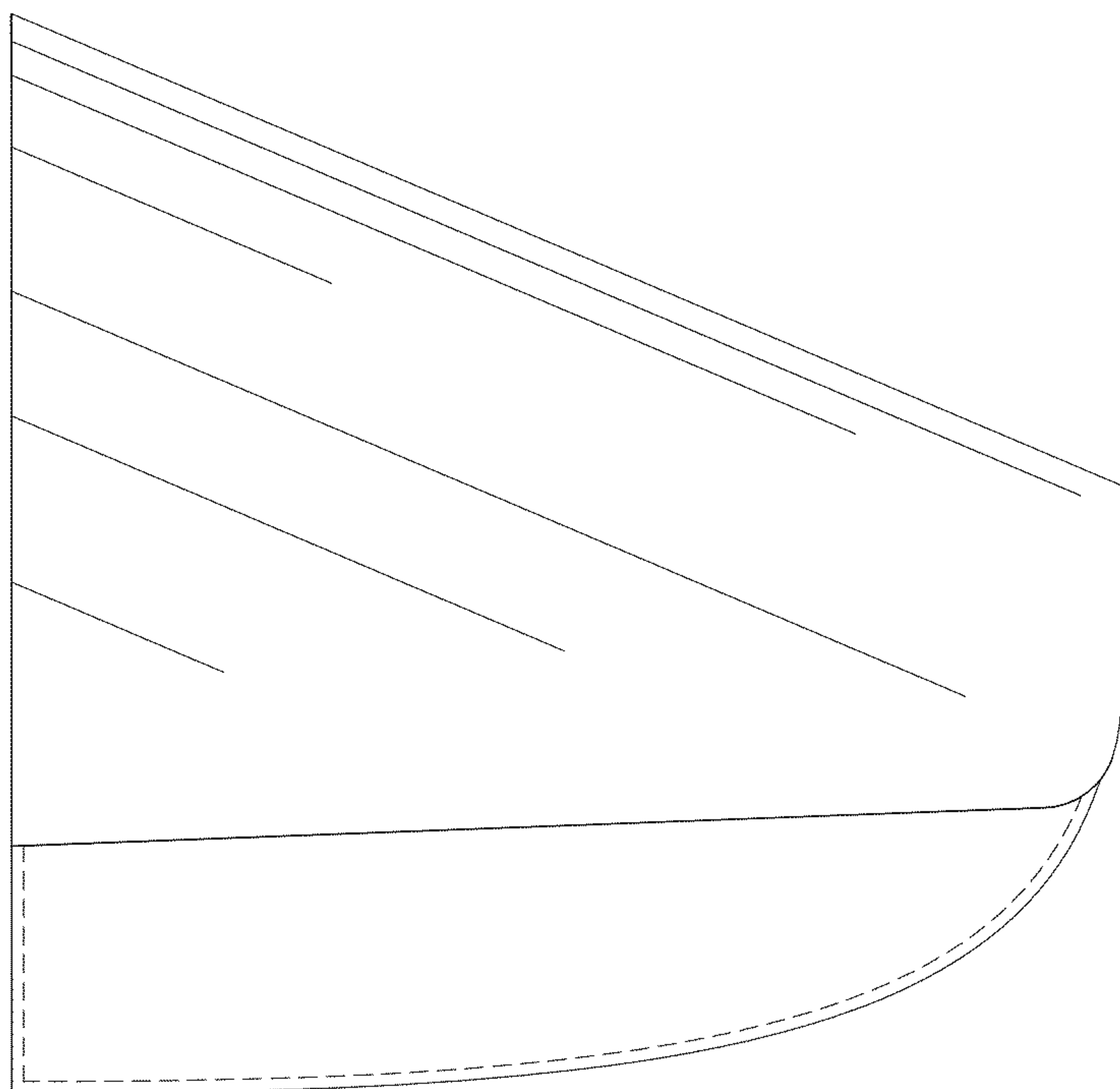

FIG. 3

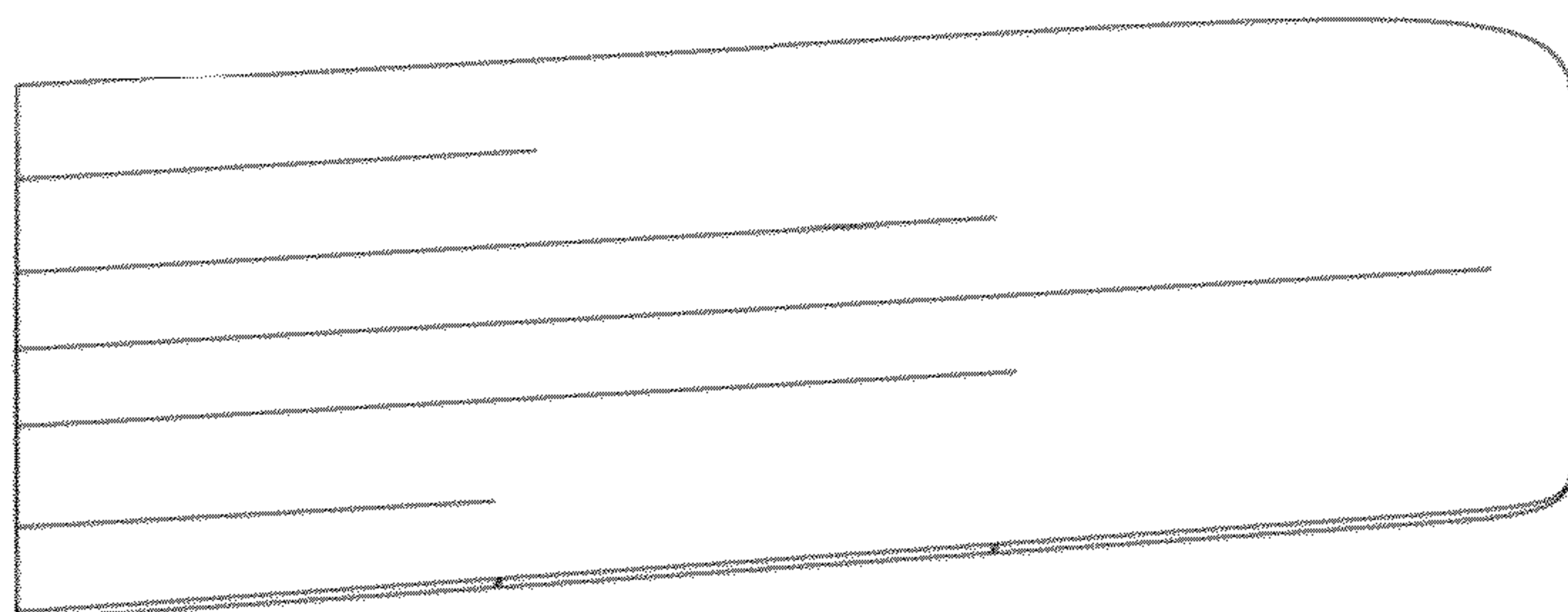

FIG. 4

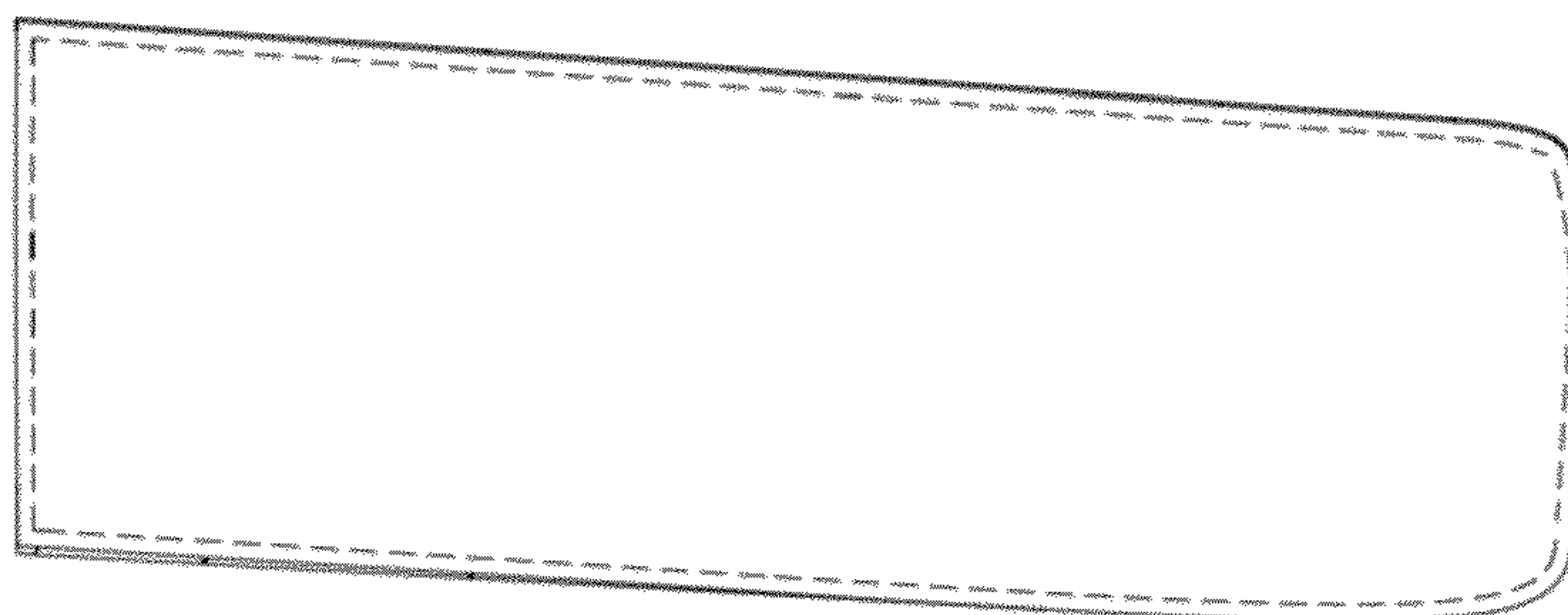

FIG. 5

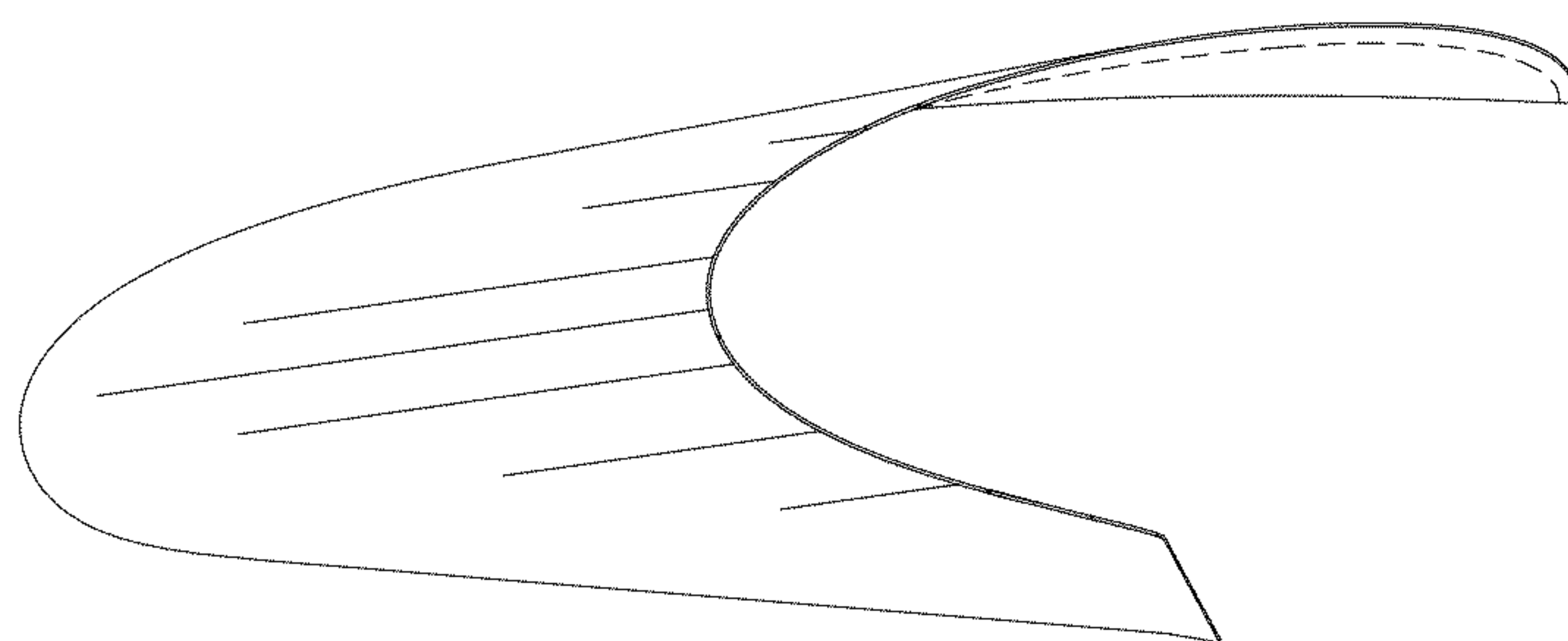

FIG. 6

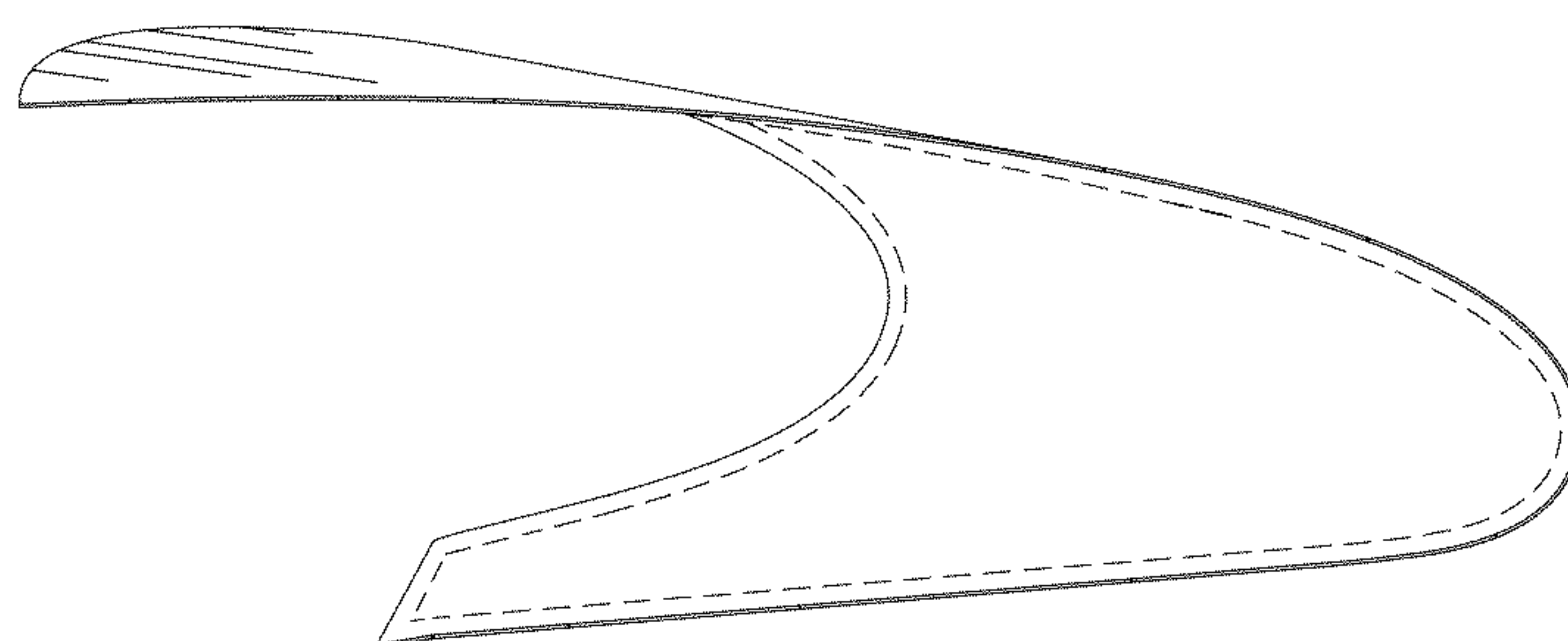

FIG. 7

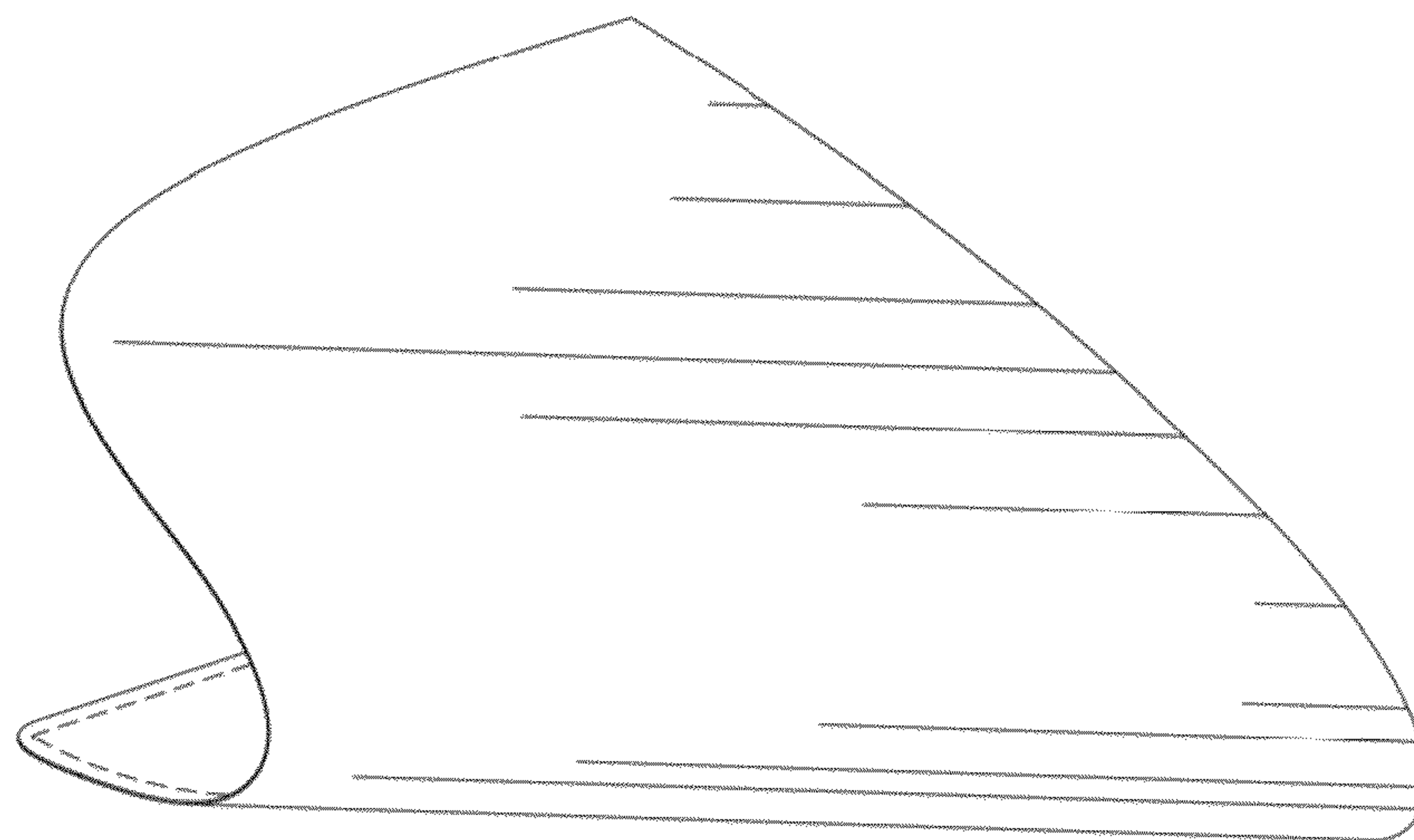

FIG. 8

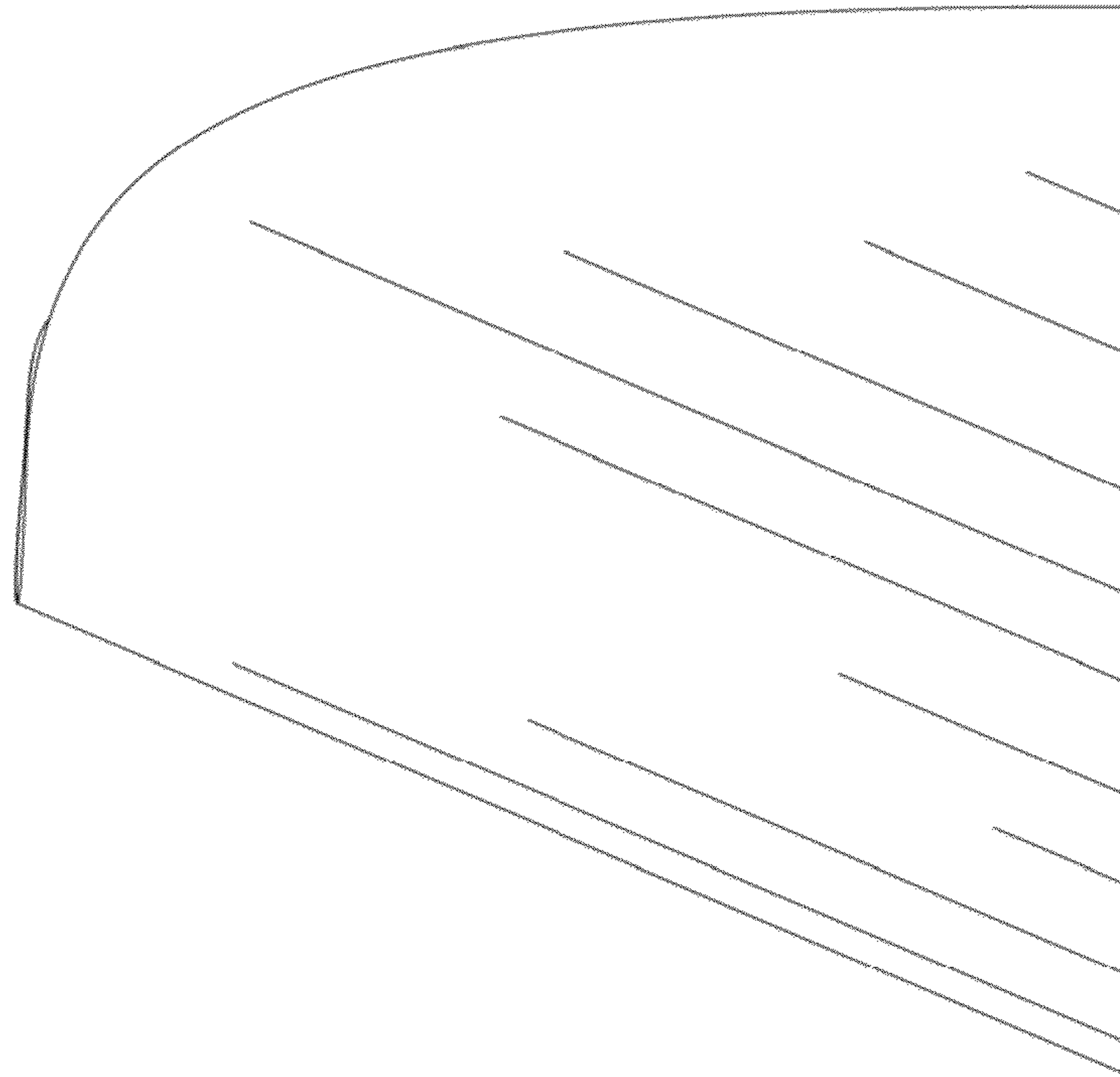

FIG. 9

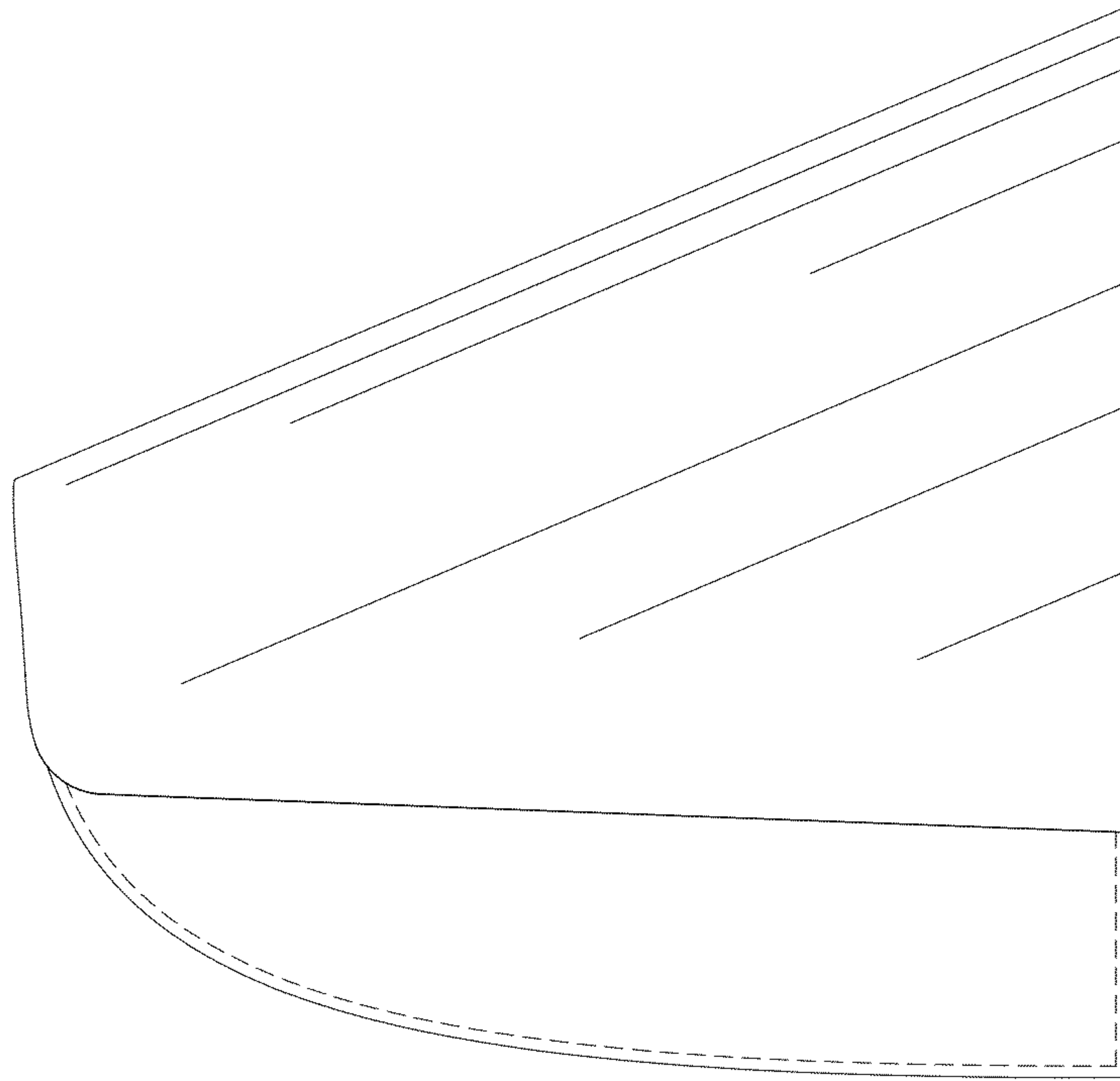

FIG. 10

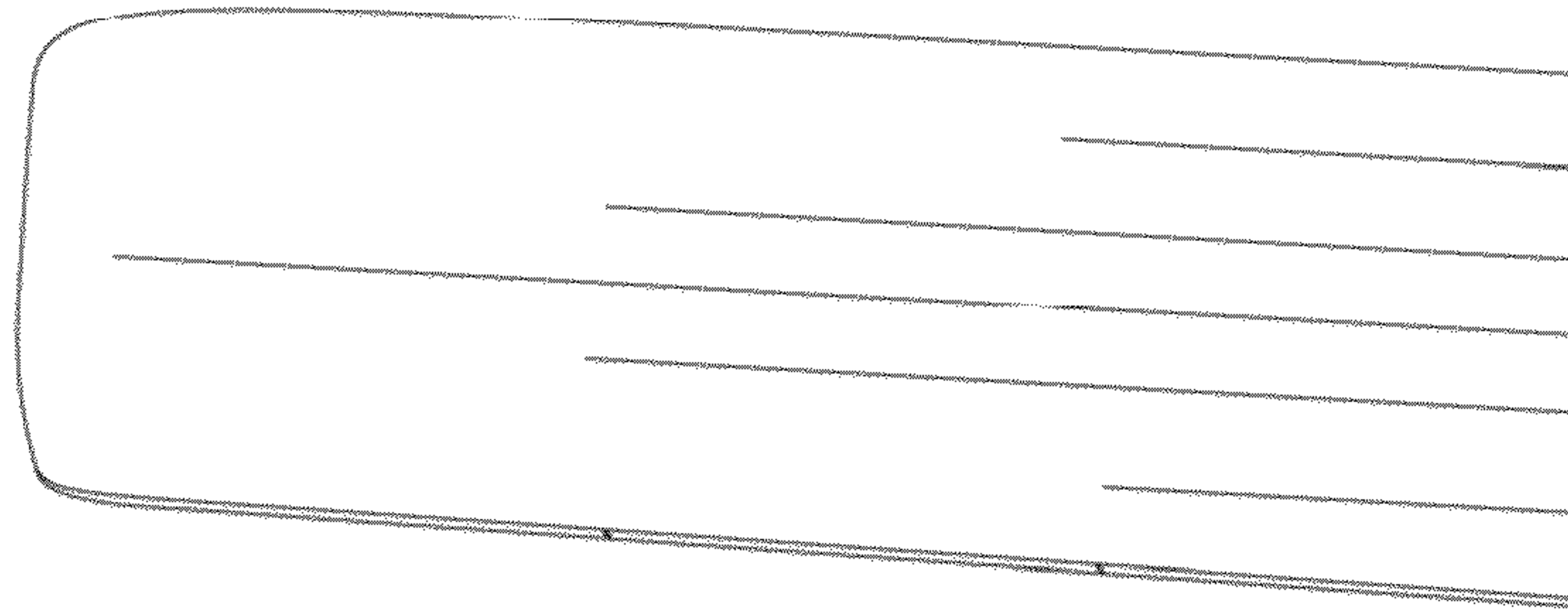

FIG. 11

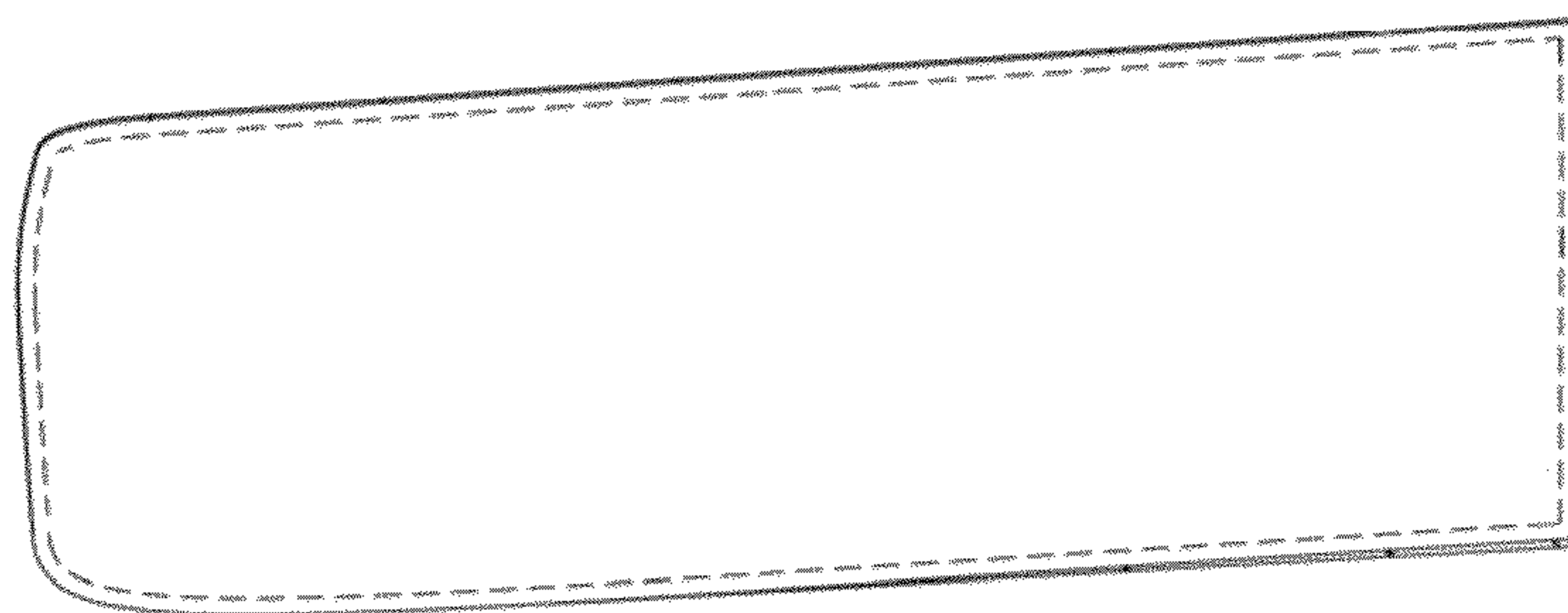

FIG. 12

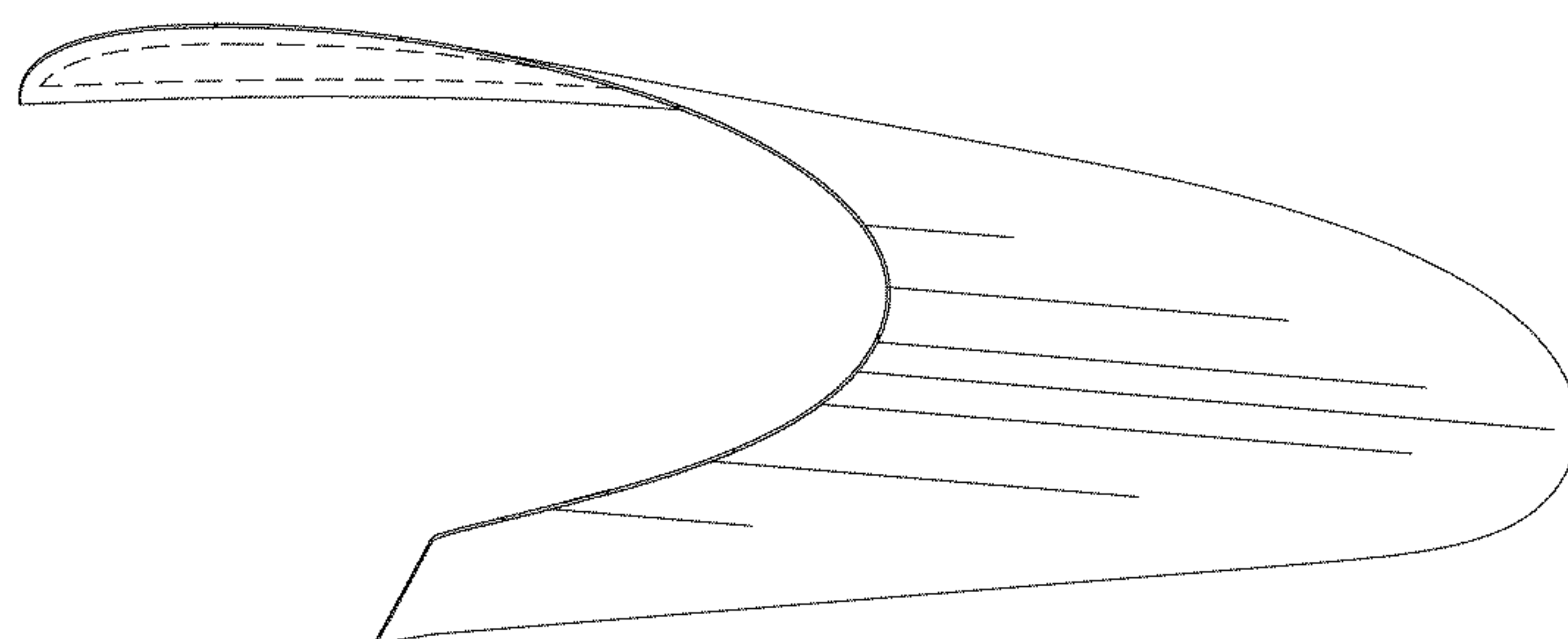

FIG. 13

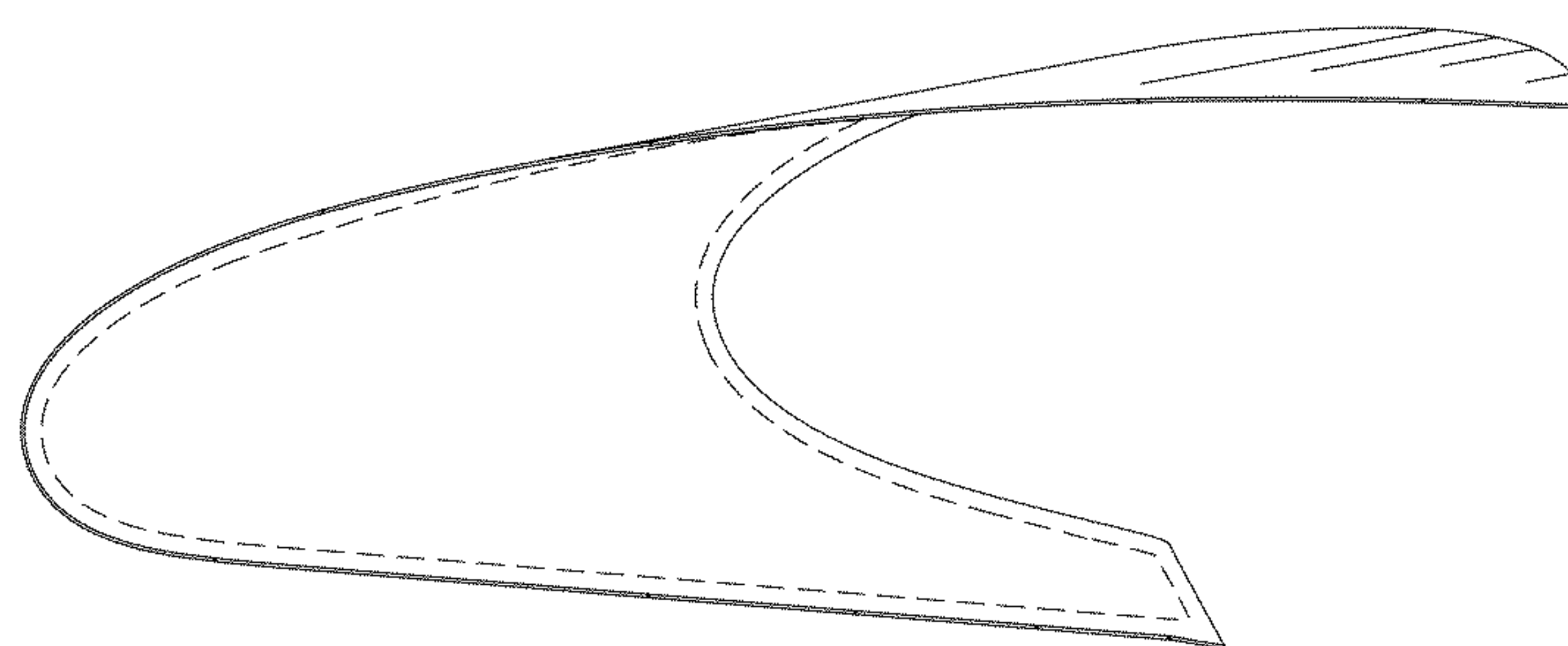

FIG. 14