



US00D753567S

(12) **United States Design Patent**  
**Boniface et al.**

(10) **Patent No.:** **US D753,567 S**

(45) **Date of Patent:** **\*\* Apr. 12, 2016**

(54) **VEHICLE REAR BUMPER**

(71) Applicant: **GM GLOBAL TECHNOLOGY OPERATIONS LLC**, Detroit, MI (US)

(72) Inventors: **Robert E. Boniface**, Bloomfield Hills, MI (US); **Robert J. Munson**, Rochester Hills, MI (US)

(73) Assignee: **GM Global Technology Operations LLC**, Detroit, MI (US)

(\*\*) Term: **14 Years**

(21) Appl. No.: **29/501,193**

(22) Filed: **Sep. 2, 2014**

(51) **LOC (10) Cl.** ..... **12-16**

(52) **U.S. Cl.**  
USPC ..... **D12/196**

(58) **Field of Classification Search**  
USPC ..... D12/169, 216, 90-92, 86, 171, 196,  
D12/163; 293/102, 113, 115, 117, 120;  
296/180.1, 180.2

CPC ..... B62D 25/08; B60R 19/02; B60R 19/03;  
B60R 19/04

See application file for complete search history.

(56) **References Cited**

**U.S. PATENT DOCUMENTS**

D663,666 S \* 7/2012 Matsumoto ..... D12/196  
D676,793 S \* 2/2013 Yamada ..... D12/196

D679,643 S \* 4/2013 Karras ..... D12/196  
D703,122 S \* 4/2014 Futschik ..... D12/196  
D715,712 S \* 10/2014 Thompson ..... D12/196  
D731,942 S \* 6/2015 Hammoud ..... D12/196  
D733,629 S \* 7/2015 Rupar ..... D12/196

**OTHER PUBLICATIONS**

Design U.S. Appl. No. 29/476,490, filed Dec. 13, 2013; First Named Inventor: Robert J. Munson; Title: Vehicle Body Exterior.

Design U.S. Appl. No. 29/498,216, filed Aug. 1, 2014; First Named Inventor: Brian J. Smith; Title: Vehicle Decklid.

Design U.S. Appl. No. 29/500,891, filed Aug. 29, 2014; First Named Inventor: Louis D. Thole; Title: Vehicle Decklid.

\* cited by examiner

*Primary Examiner* — Melody N Brown

(74) *Attorney, Agent, or Firm* — Reising Ethington P.C.

(57) **CLAIM**

The ornamental design for a vehicle rear bumper, as shown and described.

**DESCRIPTION**

FIG. 1 is a front perspective view of a vehicle rear bumper showing our new design;

FIG. 2 is a front view thereof;

FIG. 3 is a top plan view thereof; and,

FIG. 4 is a right side elevation view thereof.

The left side elevation view of the vehicle rear bumper is omitted because the left side elevation view is identical to the right side elevation view.

**1 Claim, 2 Drawing Sheets**

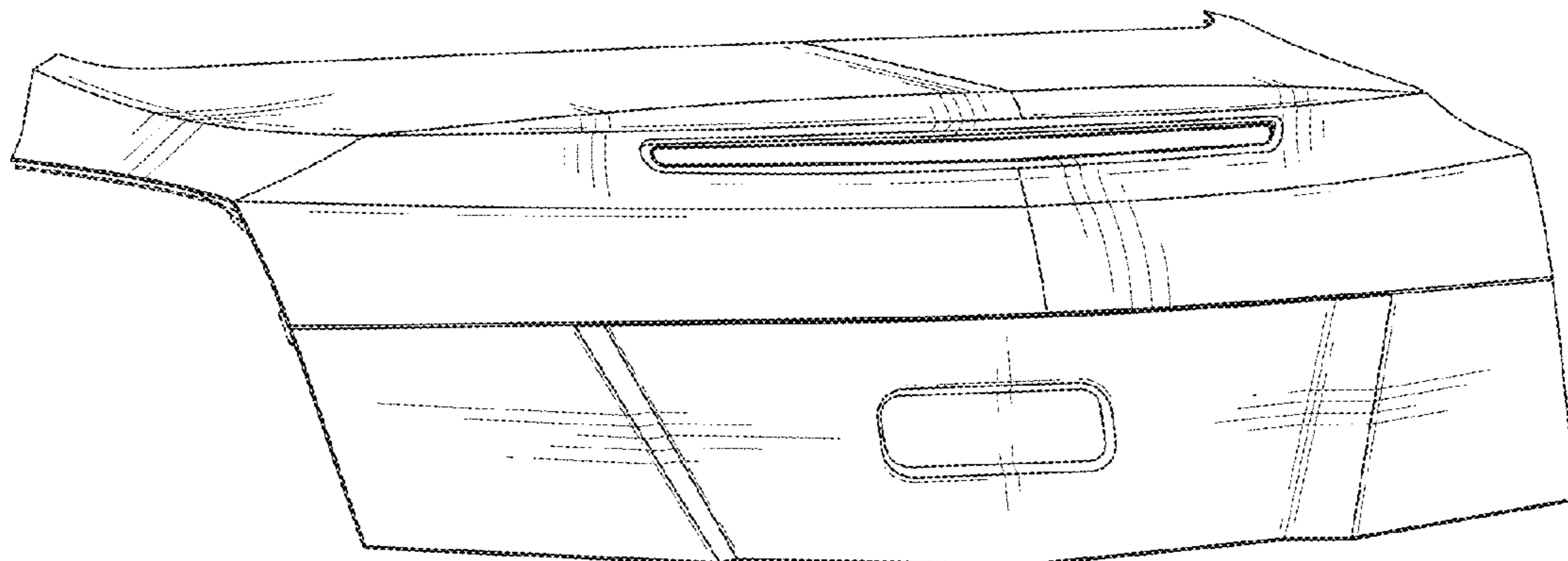

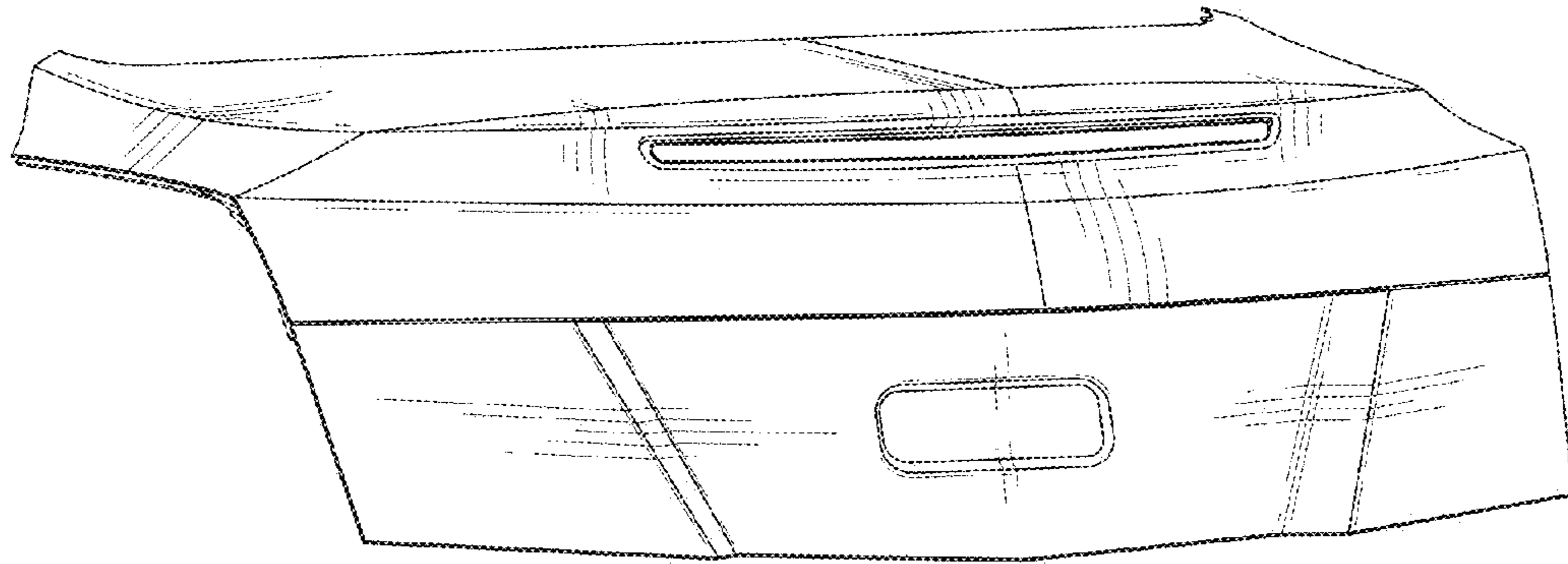

Fig-1

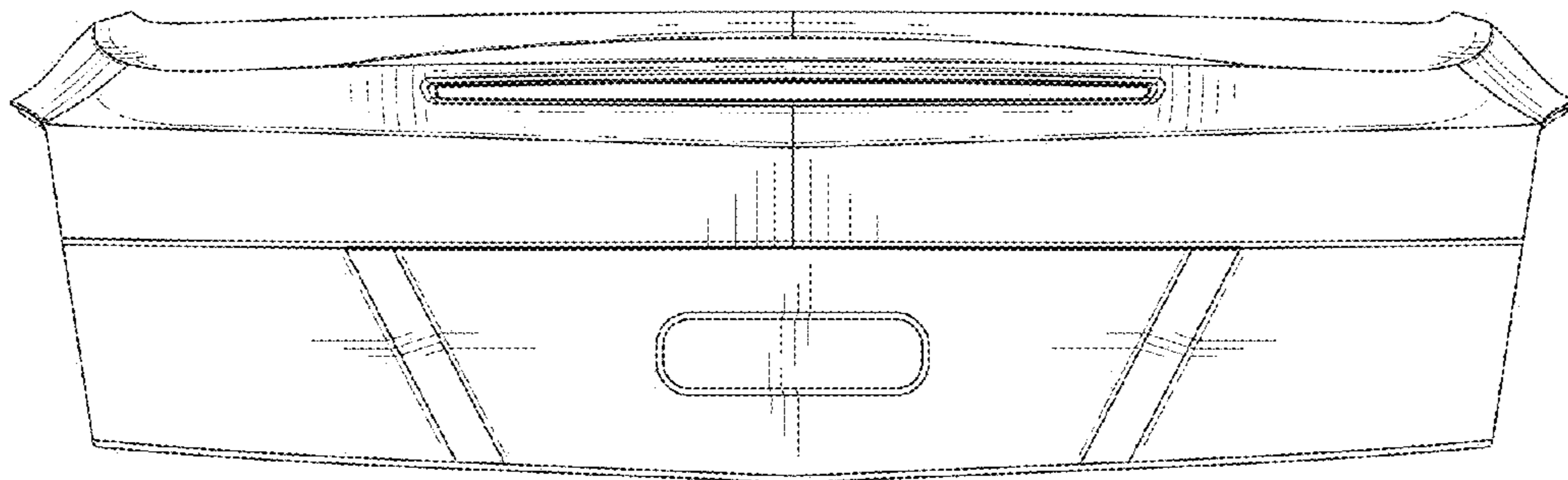

Fig-2

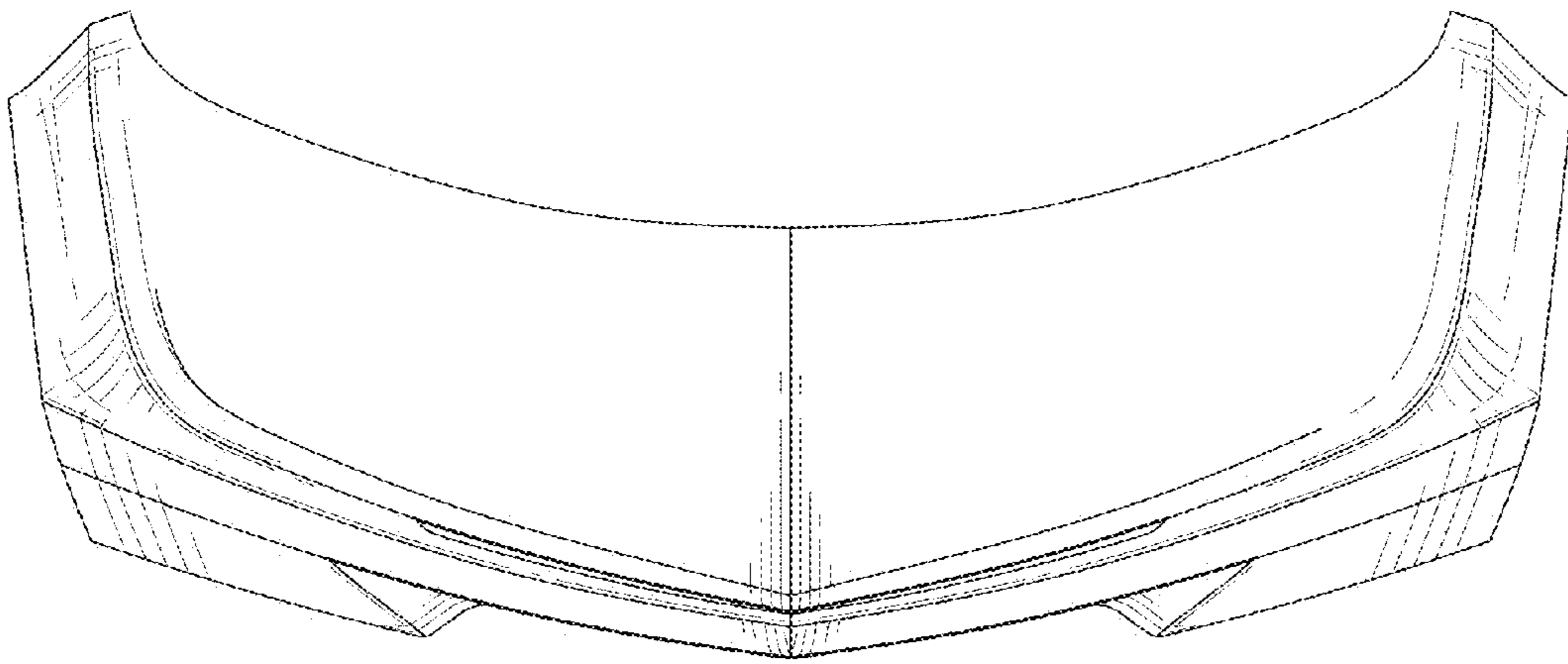

Fig-3

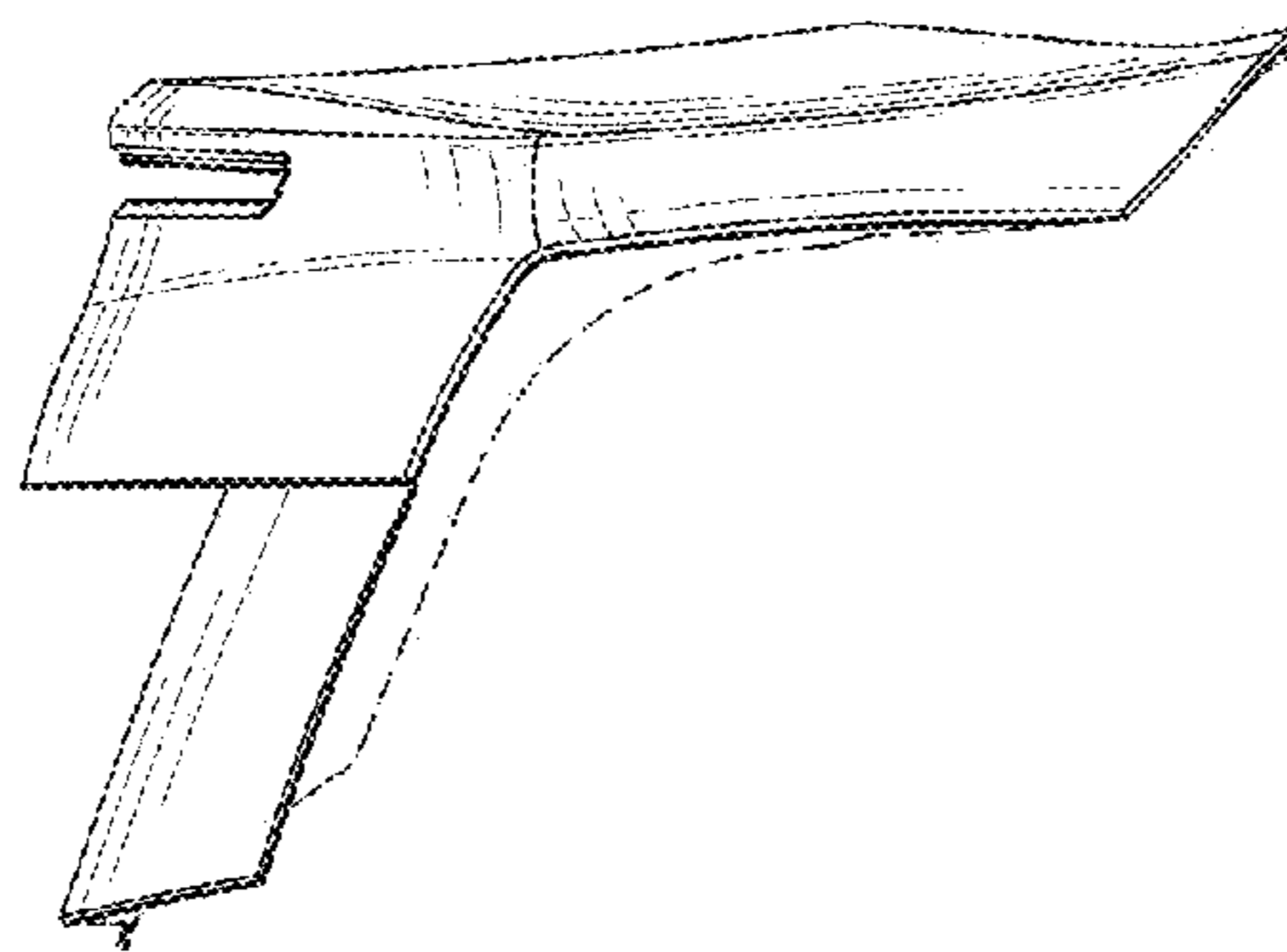

Fig-4

UNITED STATES PATENT AND TRADEMARK OFFICE  
**CERTIFICATE OF CORRECTION**

PATENT NO. : D753,567 S  
APPLICATION NO. : 29/501193  
DATED : April 12, 2016  
INVENTOR(S) : Boniface et al.

Page 1 of 1

It is certified that error appears in the above-identified patent and that said Letters Patent is hereby corrected as shown below:

On the Title Page

Item (54) and in the Specification, Column 1, Should Be: "Vehicle Decklid" not "Vehicle Rear Bumper"

Signed and Sealed this  
Seventh Day of February, 2017



Michelle K. Lee  
*Director of the United States Patent and Trademark Office*