



US00D753268S

(12) **United States Design Patent**
Nishimura

(10) **Patent No.:** **US D753,268 S**
(45) **Date of Patent:** **** Apr. 5, 2016**

(54) **FLOW-RATE CONTROL VALVE**

(71) Applicant: **SMC CORPORATION**, Tokyo (JP)
(72) Inventor: **Akiho Nishimura**, Moriya (JP)
(73) Assignee: **SMC CORPORATION**, Tokyo (JP)
(**) Term: **14 Years**

(21) Appl. No.: **29/515,260**

(22) Filed: **Jan. 21, 2015**

(30) **Foreign Application Priority Data**

Jul. 30, 2014 (CN) 2014 3 0262693

(51) **LOC (10) Cl.** **23-01**

(52) **U.S. Cl.**
USPC **D23/233**

(58) **Field of Classification Search**

USPC D23/233-250; 137/498, 545, 547, 549,
137/377; 251/129.15, 129.01, 250
CPC F16K 47/08; F16K 15/188; F16K 31/12;
F16K 5/10; F16K 11/0716
See application file for complete search history.

(56) **References Cited**

U.S. PATENT DOCUMENTS

D623,271 S	9/2010	Yamada	
8,141,582 B2 *	3/2012	Fukano F16K 7/16 116/277
D722,362 S *	2/2015	Kluss D23/235
D722,363 S *	2/2015	Kluss D23/235
D736,896 S *	8/2015	Nishimura D23/233

* cited by examiner

FOREIGN PATENT DOCUMENTS

JP D1368781 S 9/2009

Primary Examiner — Cynthia Ramirez

Assistant Examiner — Gino Colan

(74) *Attorney, Agent, or Firm* — Birch, Stewart, Kolasch & Birch, LLP

(57) **CLAIM**

The ornamental design for a flow-rate control valve, as shown.

DESCRIPTION

FIG. 1 is a front, top and left side perspective view of a flow-rate control valve showing a first embodiment of my design;

FIG. 2 is a front view thereof;

FIG. 3 is a rear view thereof;

FIG. 4 is a top plan view thereof;

FIG. 5 is a bottom plan view thereof;

FIG. 6 is a left side view thereof;

FIG. 7 is a right side view thereof;

FIG. 8 is a front, top and left side perspective view of a flow-rate control valve showing a second embodiment of my design;

FIG. 9 is a front view thereof;

FIG. 10 is a rear view thereof;

FIG. 11 is a top plan view thereof;

FIG. 12 is a bottom plan view thereof;

FIG. 13 is a left side view thereof;

FIG. 14 is a right side view thereof;

FIG. 15 is a front, top and left side perspective view of a flow-rate control valve showing a third embodiment of my design;

FIG. 16 is a front view thereof;

FIG. 17 is a rear view thereof;

FIG. 18 is a top plan view thereof;

FIG. 19 is a bottom plan view thereof;

FIG. 20 is a left side view thereof;

FIG. 21 is a right side view thereof;

FIG. 22 is a front, top and left side perspective view of a flow-rate control valve showing a fourth embodiment of my design;

FIG. 23 is a front view thereof;

FIG. 24 is a rear view thereof;

FIG. 25 is a top plan view thereof;

FIG. 26 is a bottom plan view thereof;

FIG. 27 is a left side view thereof;

FIG. 28 is a right side view thereof;

FIG. 29 is a front, top and left side perspective view of a flow-rate control valve showing a fifth embodiment of my design;

FIG. 30 is a front view thereof;

FIG. 31 is a rear view thereof;

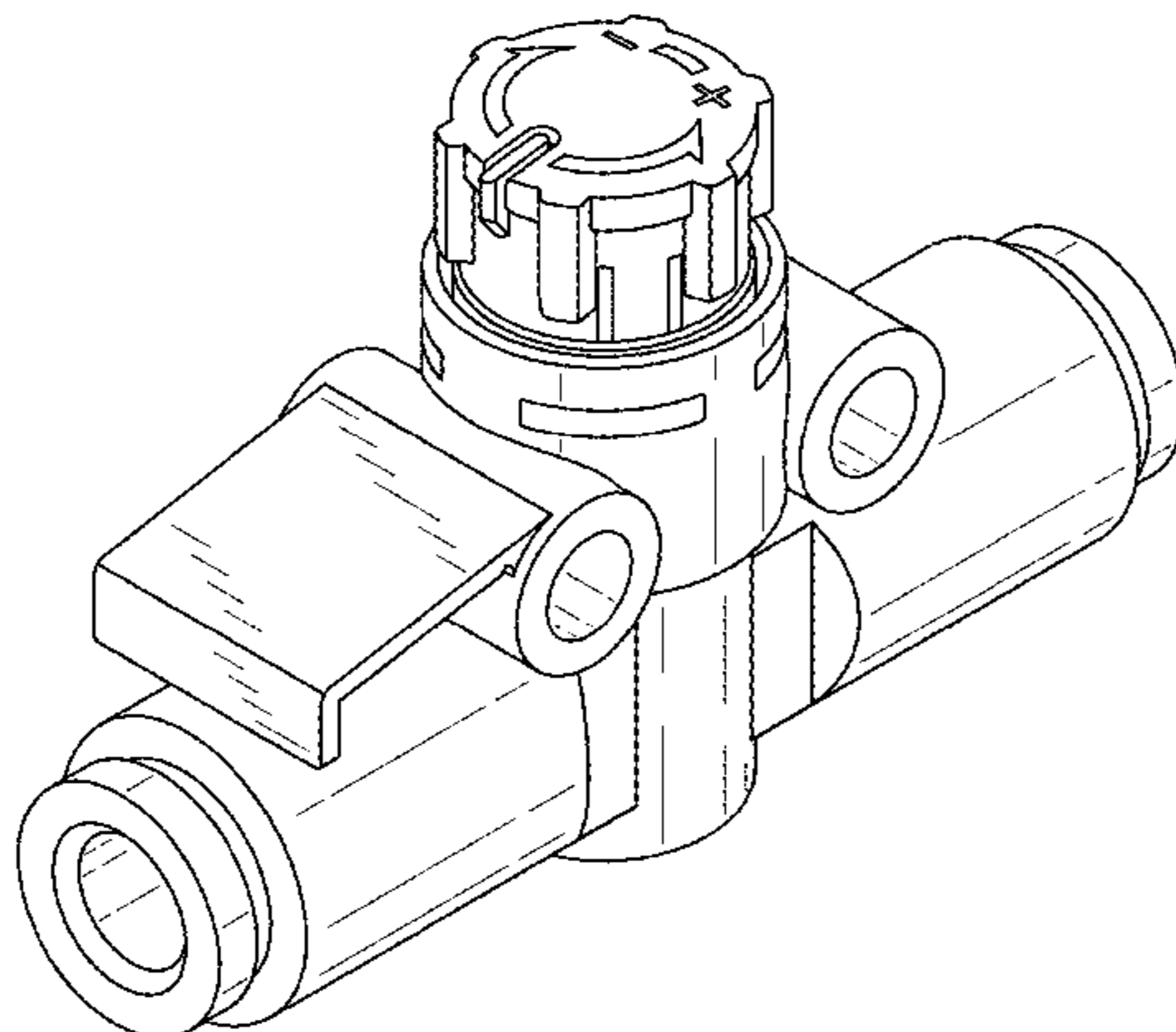

FIG. 32 is a top plan view thereof;
FIG. 33 is a bottom plan view thereof;
FIG. 34 is a left side view thereof;
FIG. 35 is a right side view thereof;
FIG. 36 is a front, top and left side perspective view of a flow-rate control valve showing a sixth embodiment of my design;
FIG. 37 is a front view thereof;
FIG. 38 is a rear view thereof;
FIG. 39 is a top plan view thereof;
FIG. 40 is a bottom plan view thereof;
FIG. 41 is a left side view thereof;

FIG. 42 is a right side view thereof;
FIG. 43 is a front, top and left side perspective view of a flow-rate control valve showing a seventh embodiment of my design;
FIG. 44 is a front view thereof;
FIG. 45 is a rear view thereof;
FIG. 46 is a top plan view thereof;
FIG. 47 is a bottom plan view thereof;
FIG. 48 is a left side view thereof; and,
FIG. 49 is a right side view thereof.

1 Claim, 49 Drawing Sheets

FIG. 1

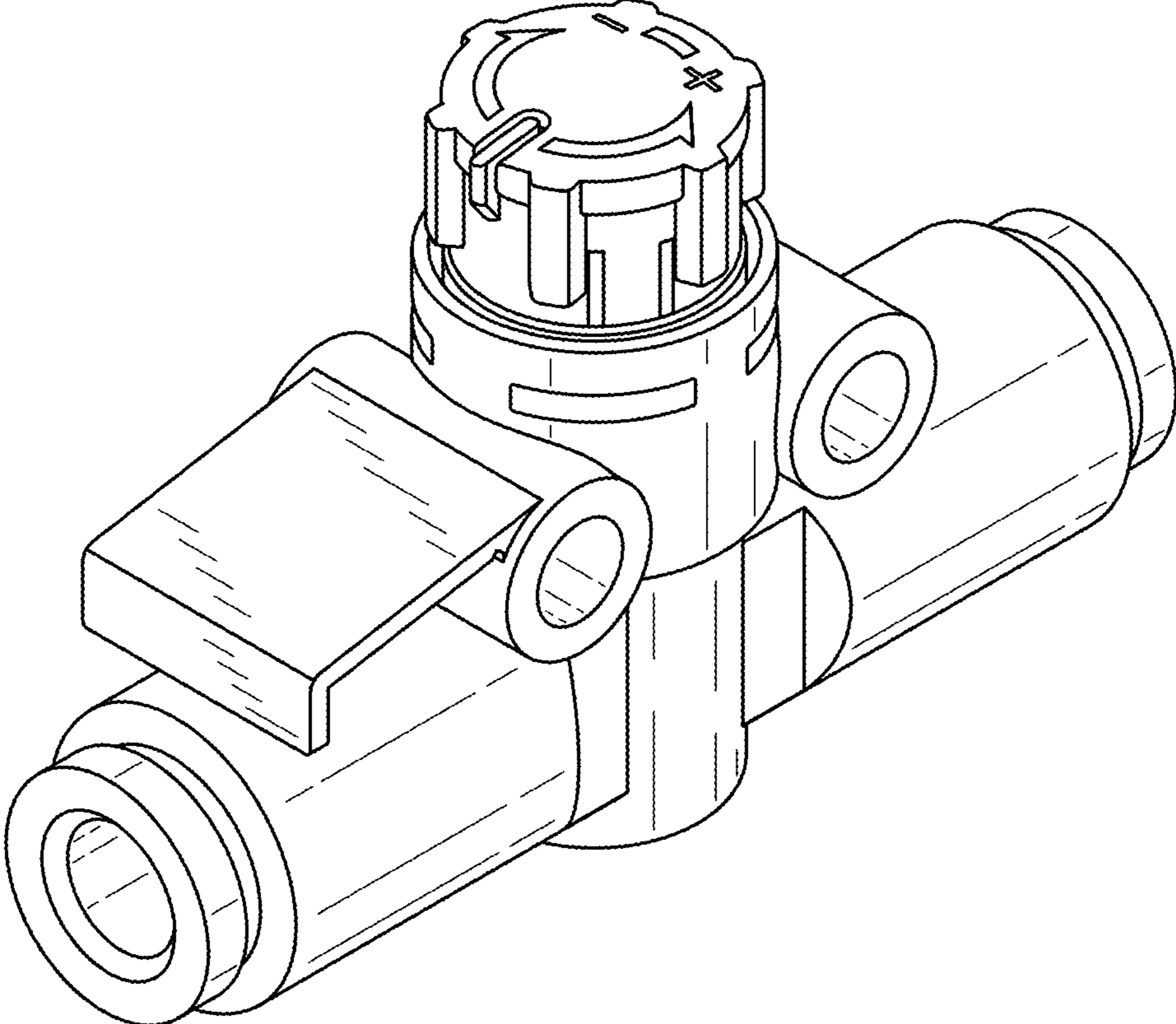

FIG. 2

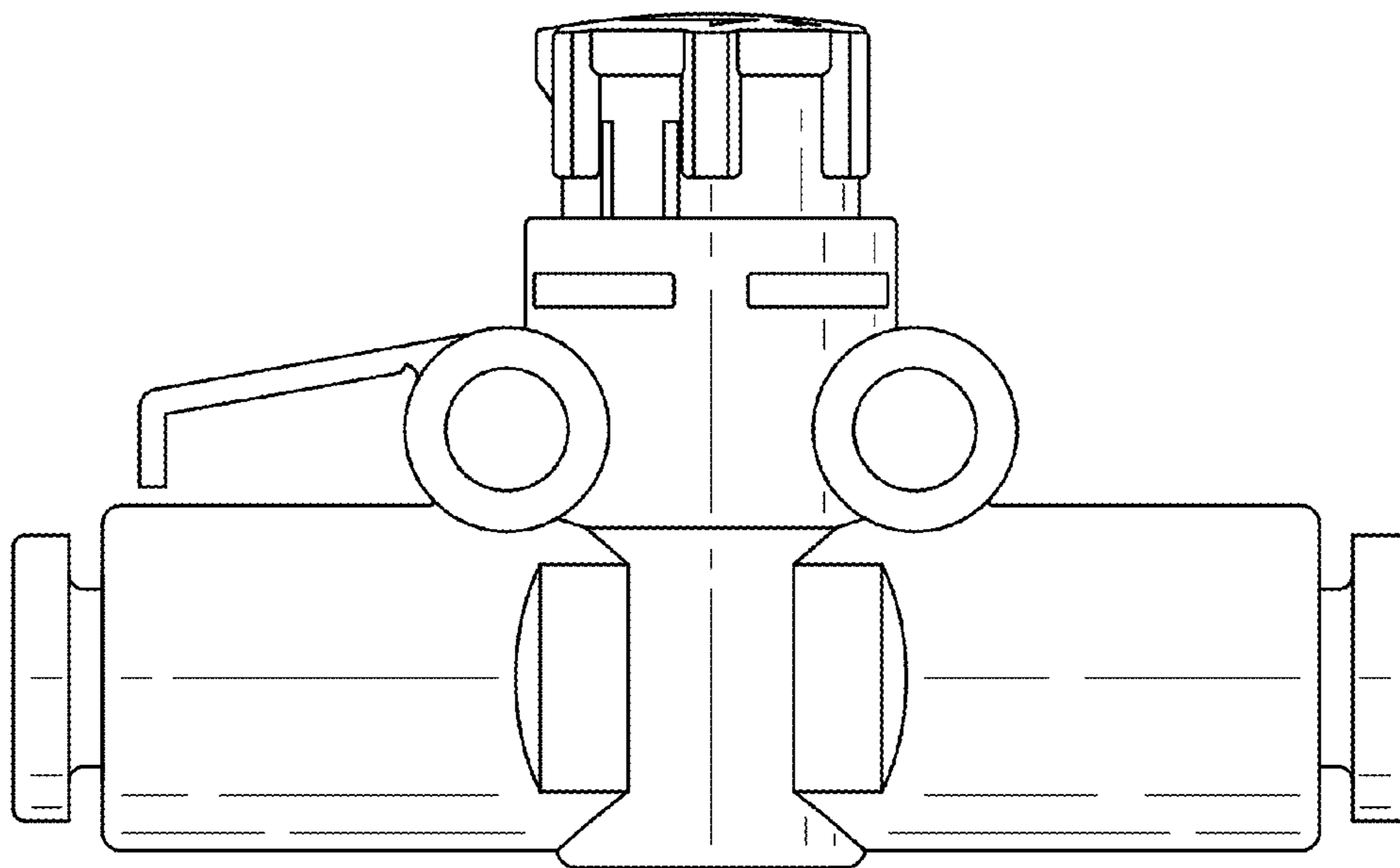

FIG. 3

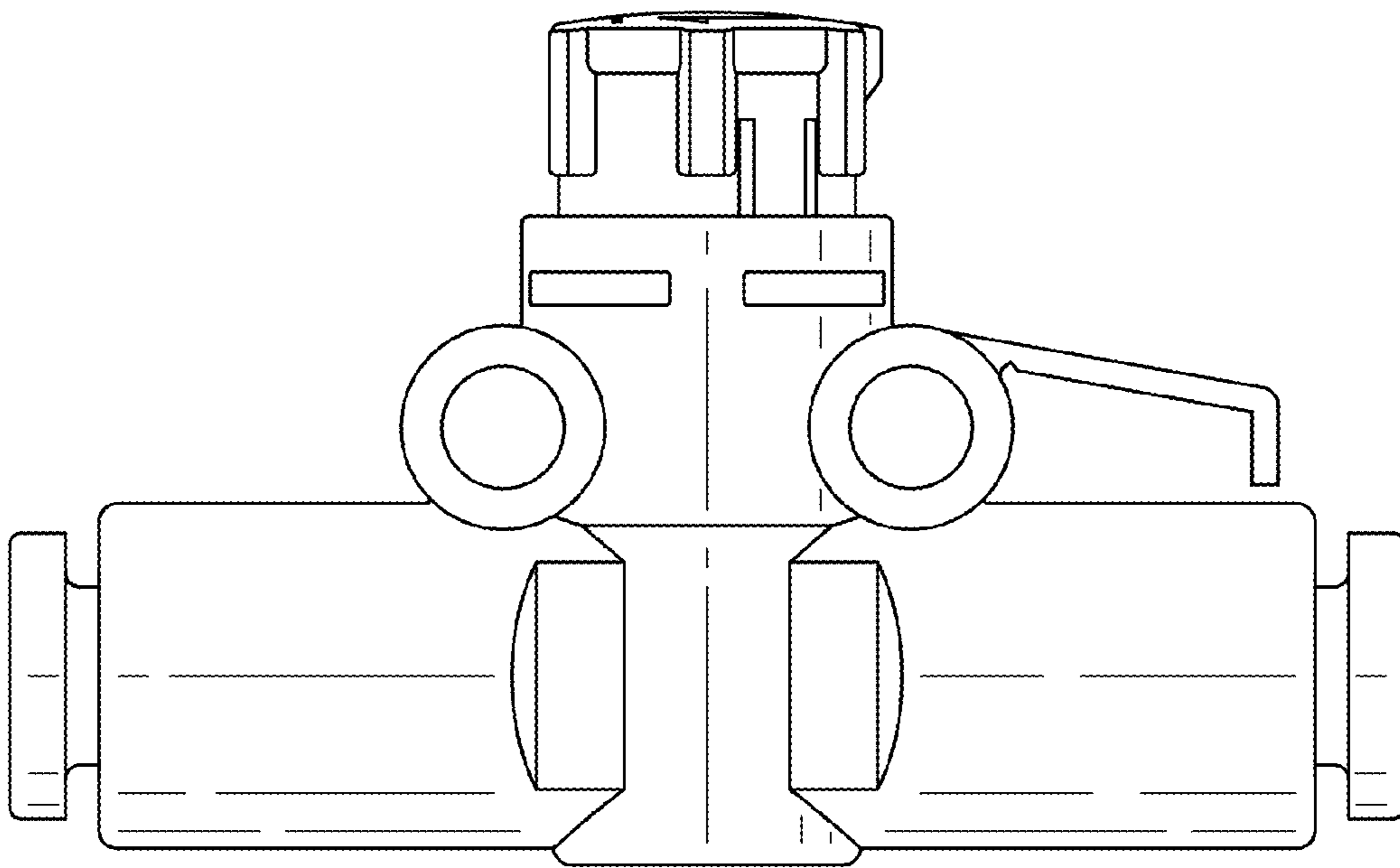

FIG. 4

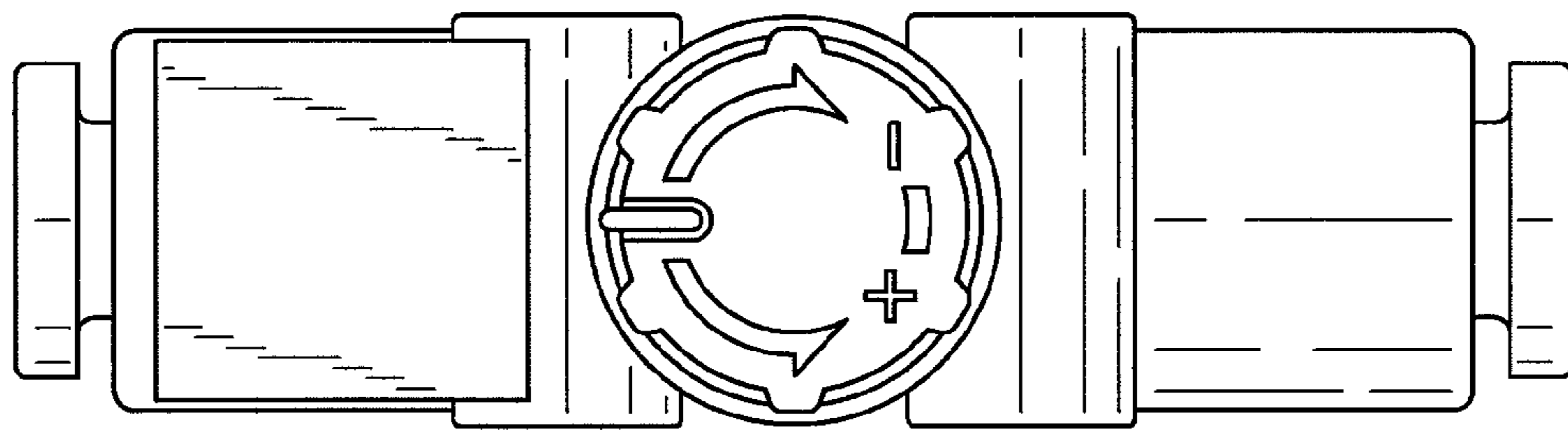

FIG. 5

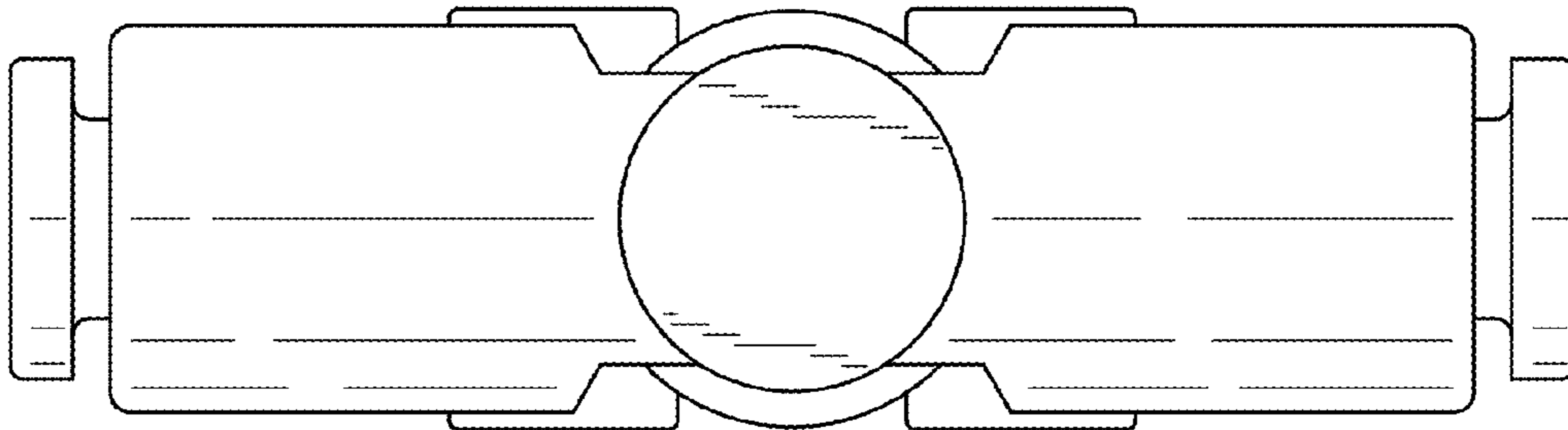

FIG. 6

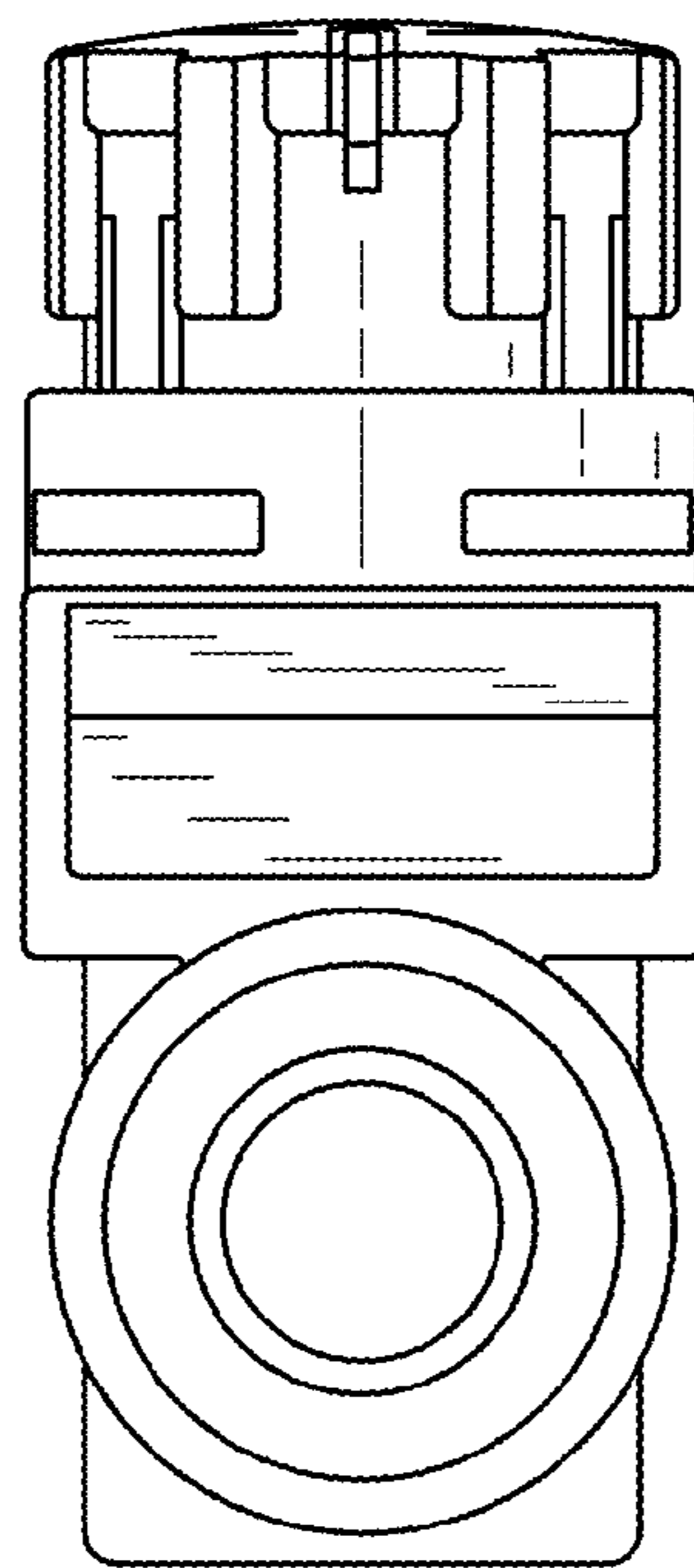

FIG. 7

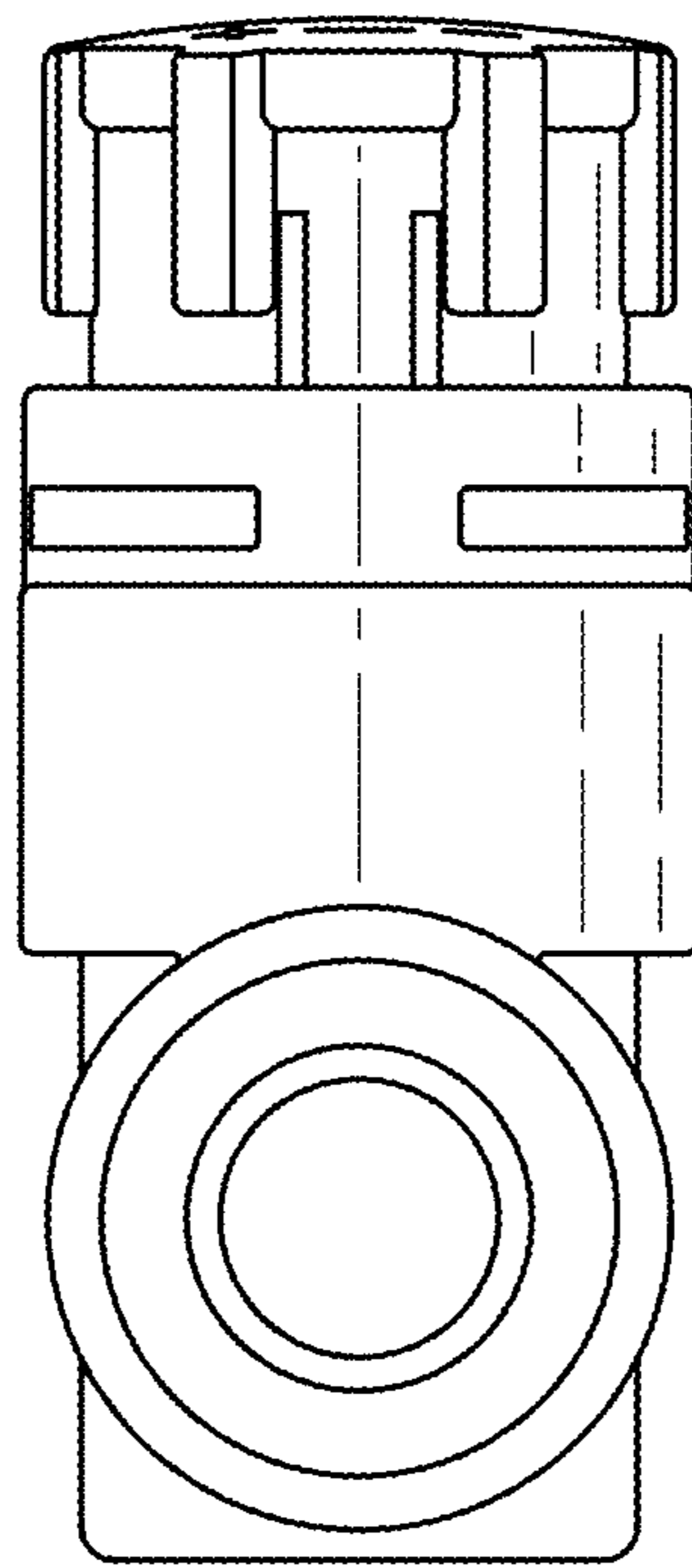

FIG. 8

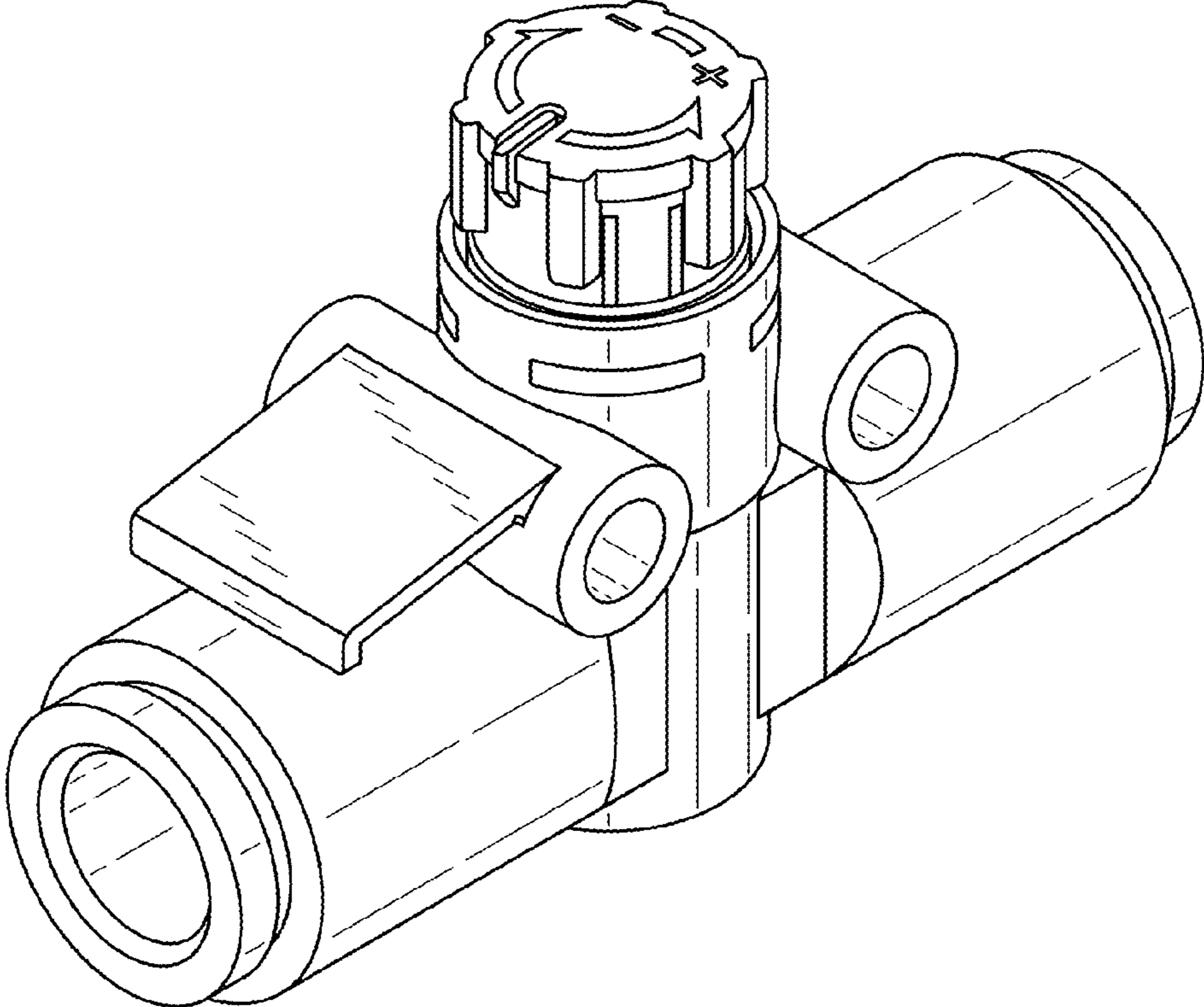

FIG. 9

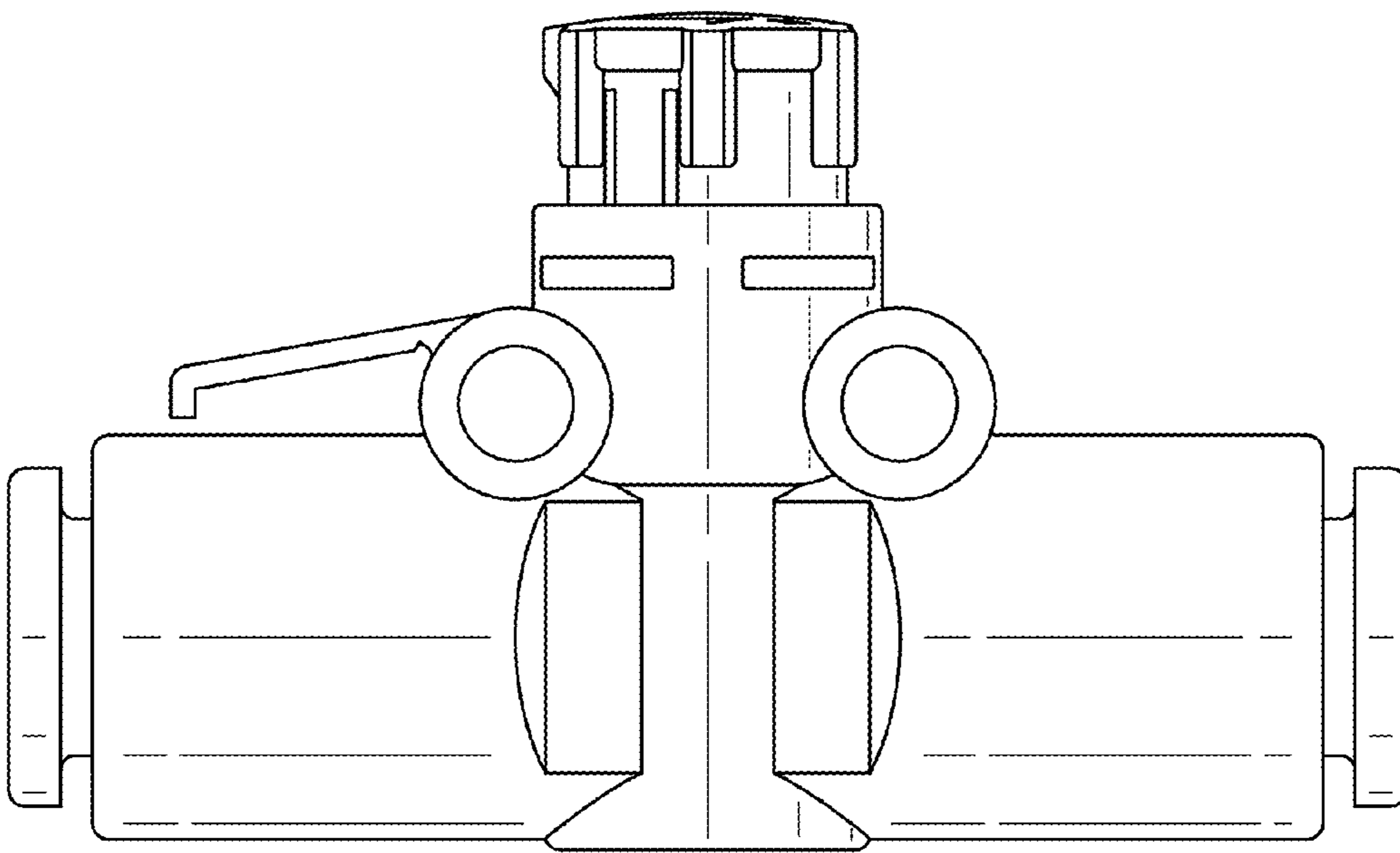

FIG. 10

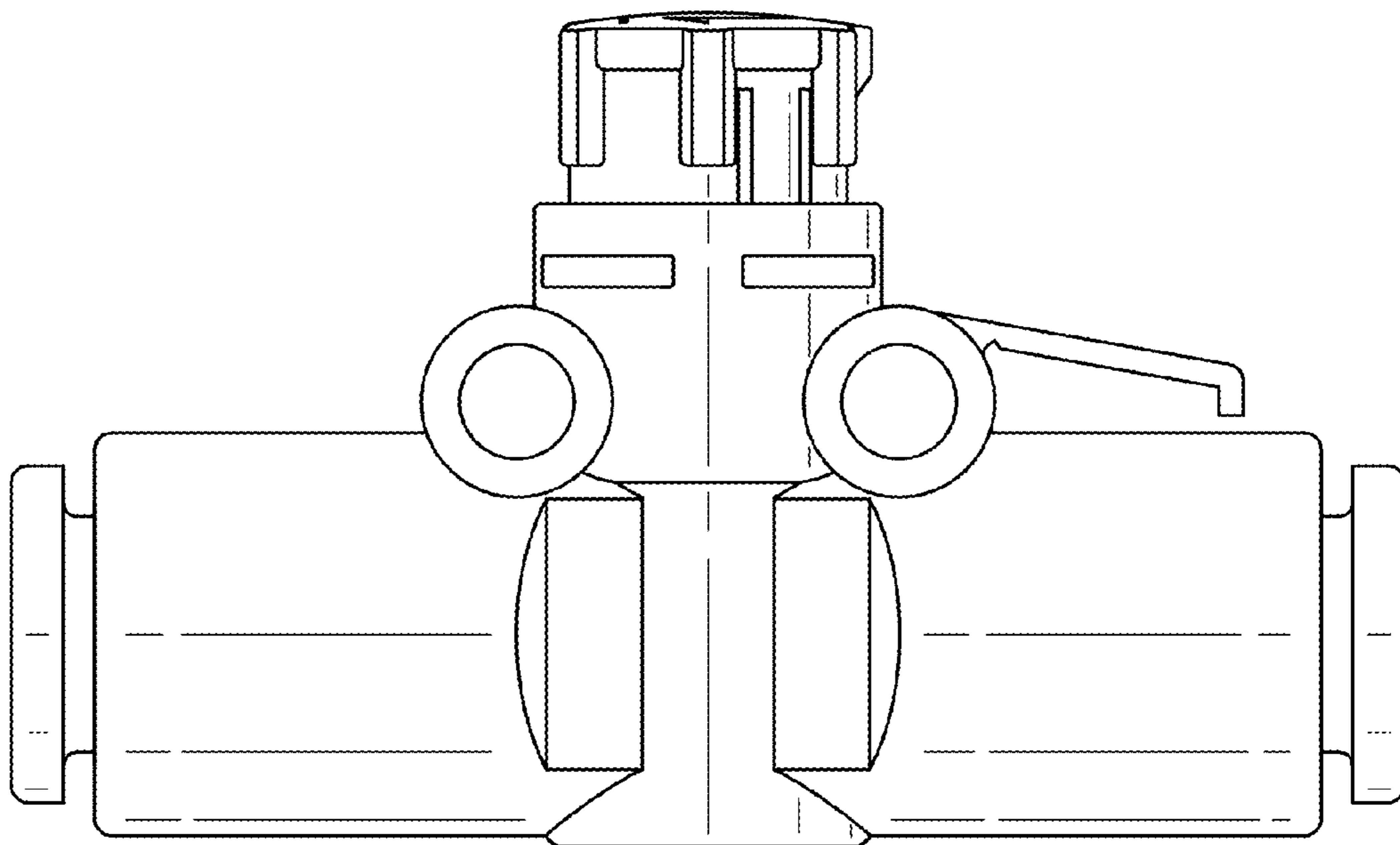

FIG. 11

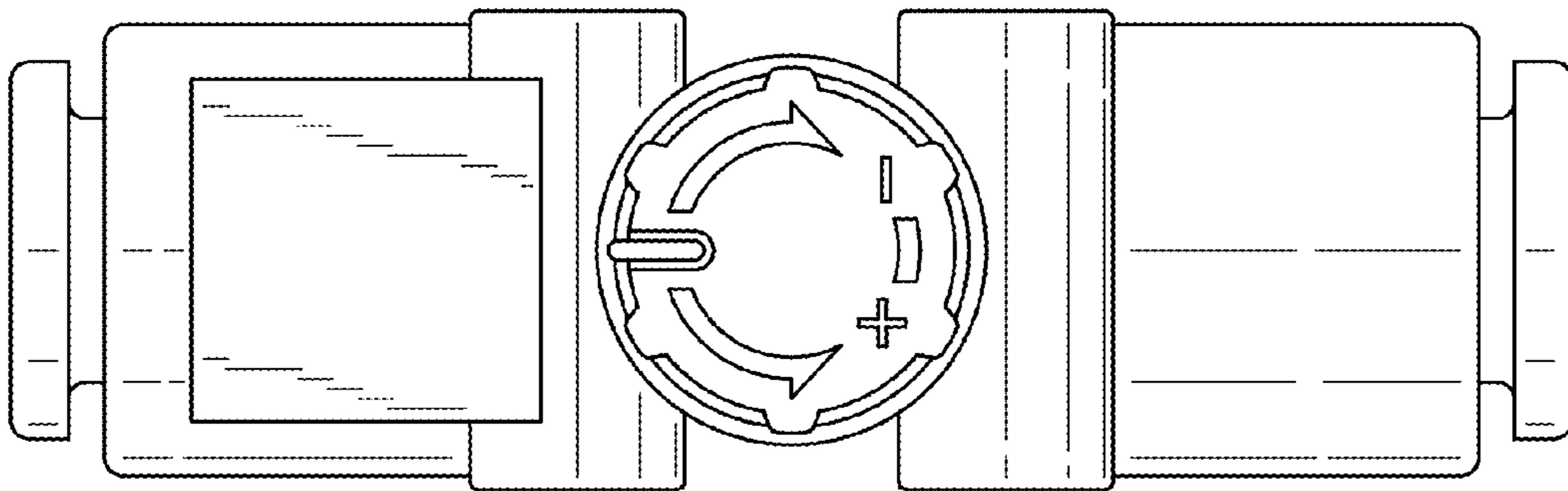

FIG. 12

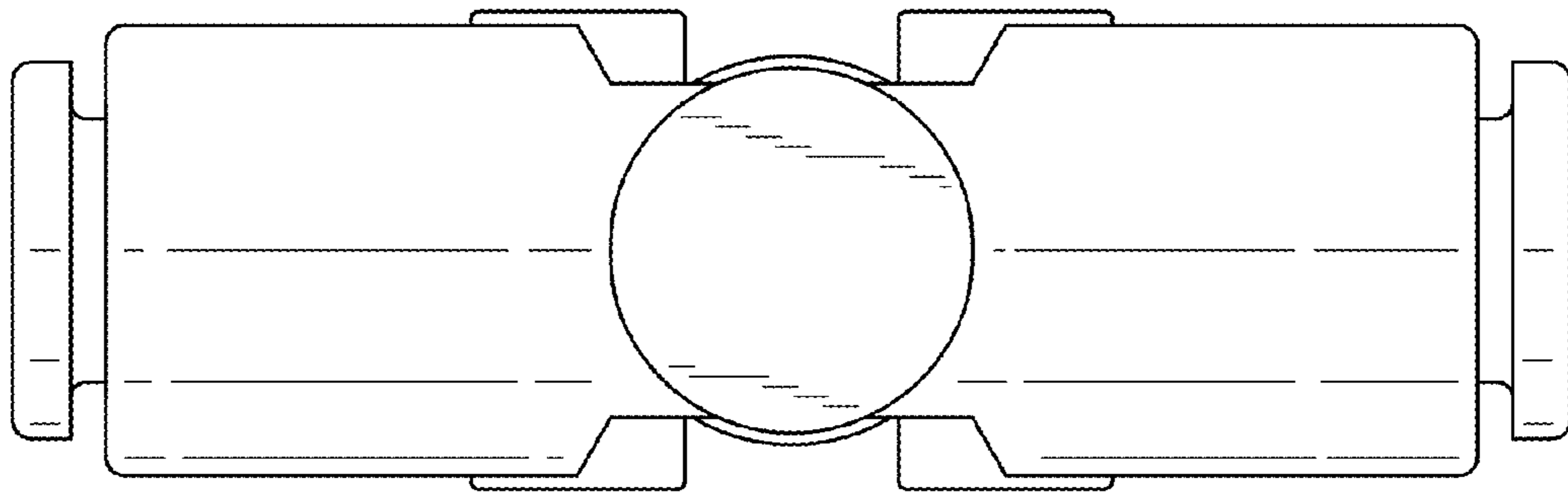

FIG. 13

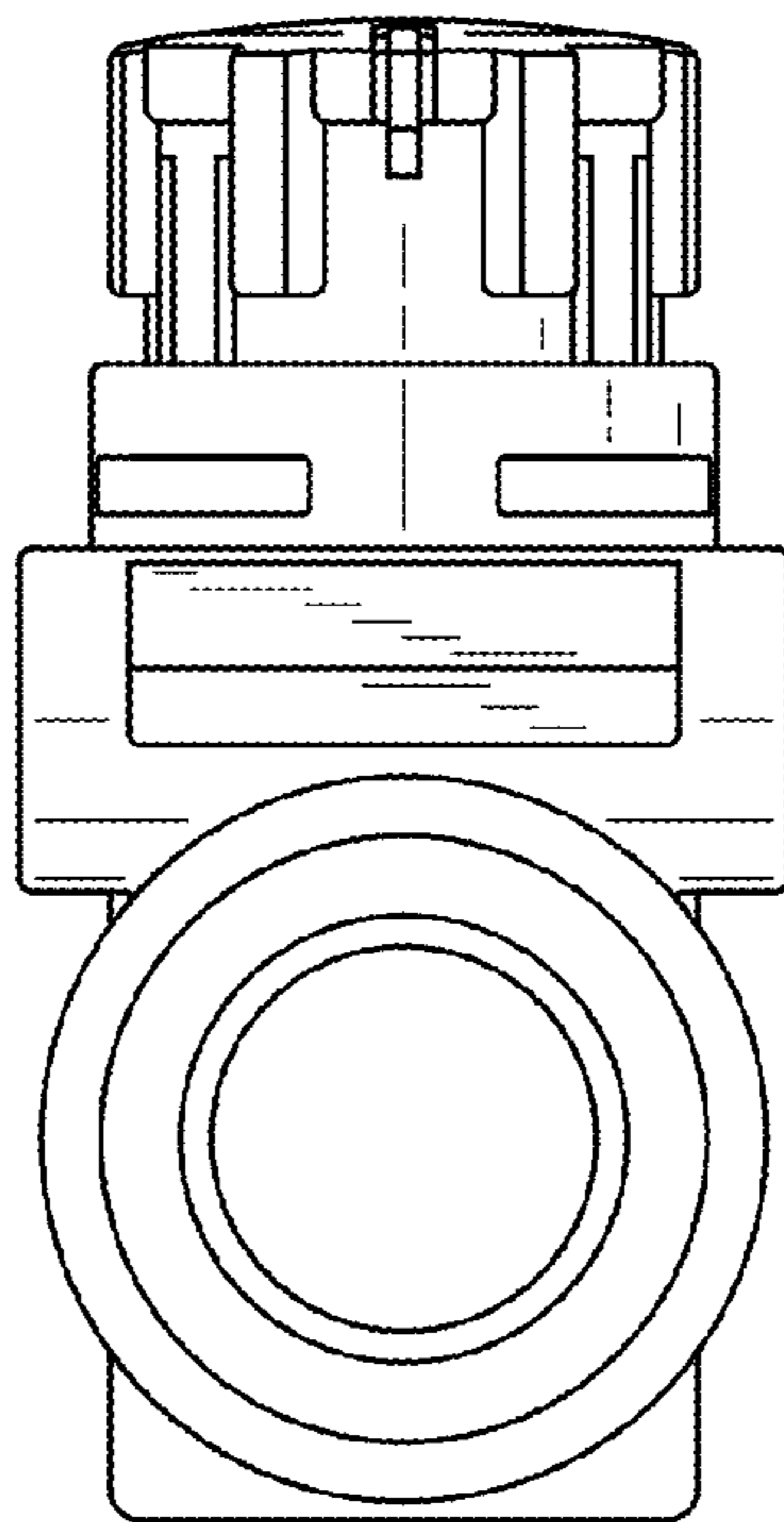

FIG. 14

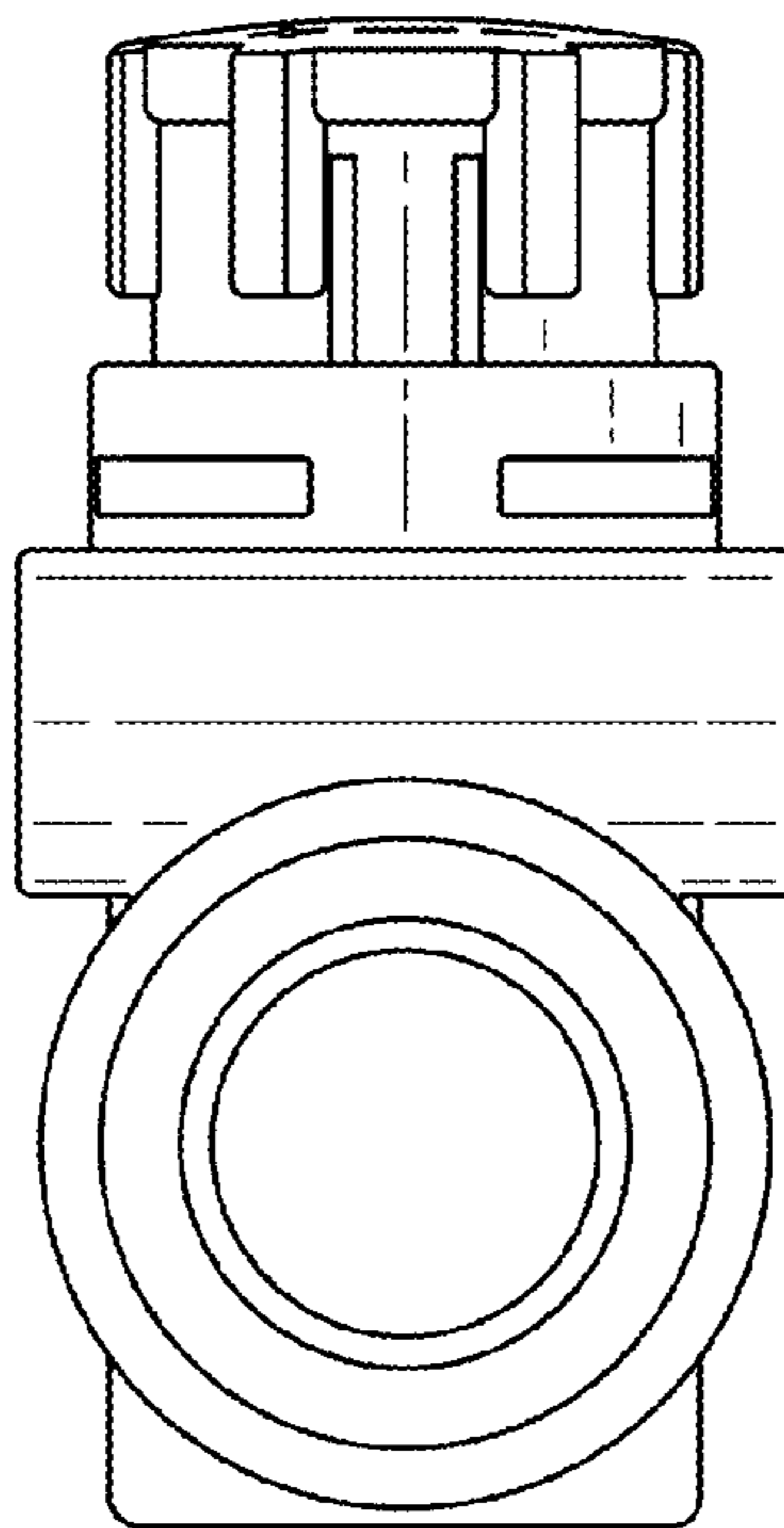

FIG. 15

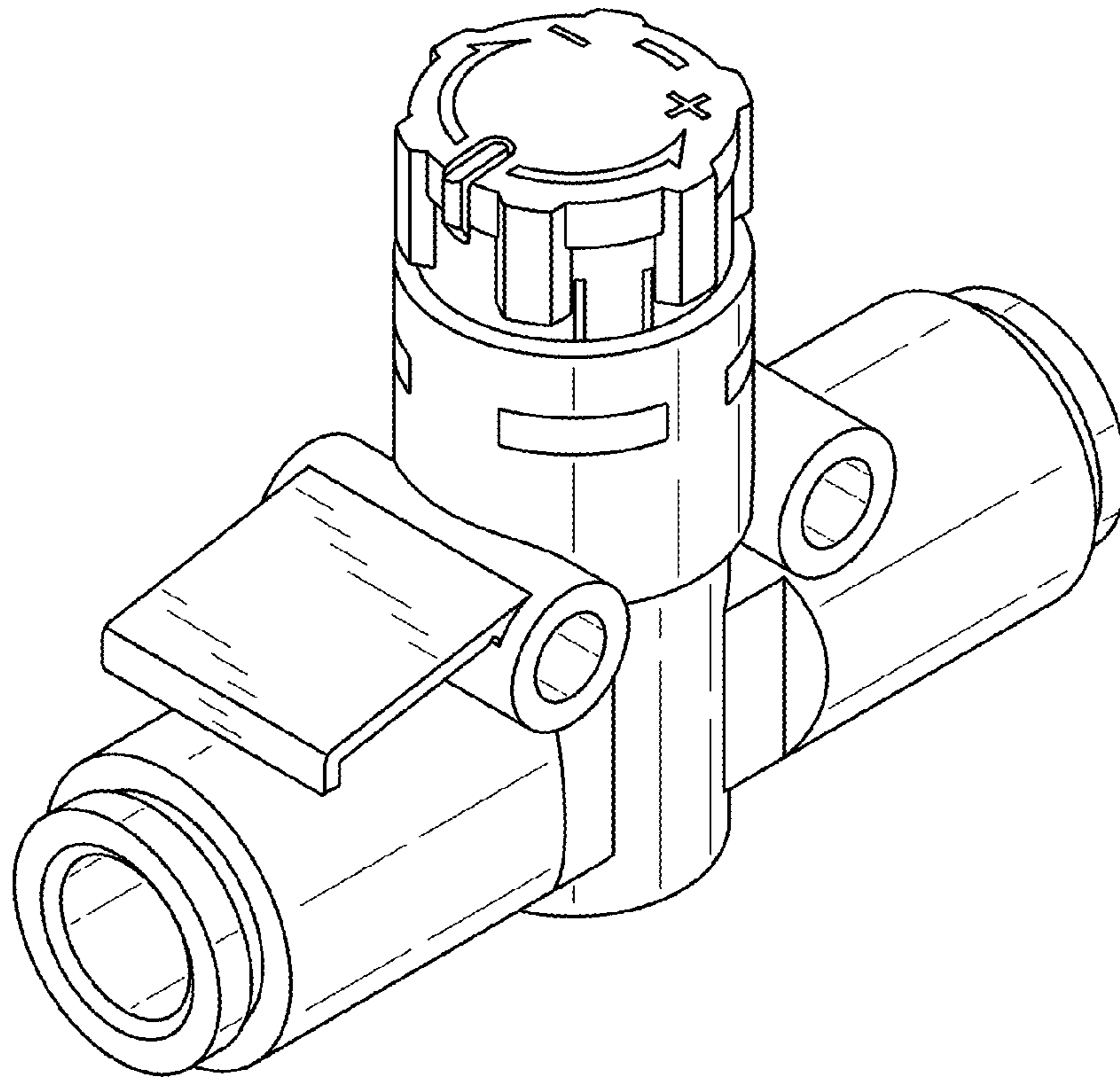

FIG. 16

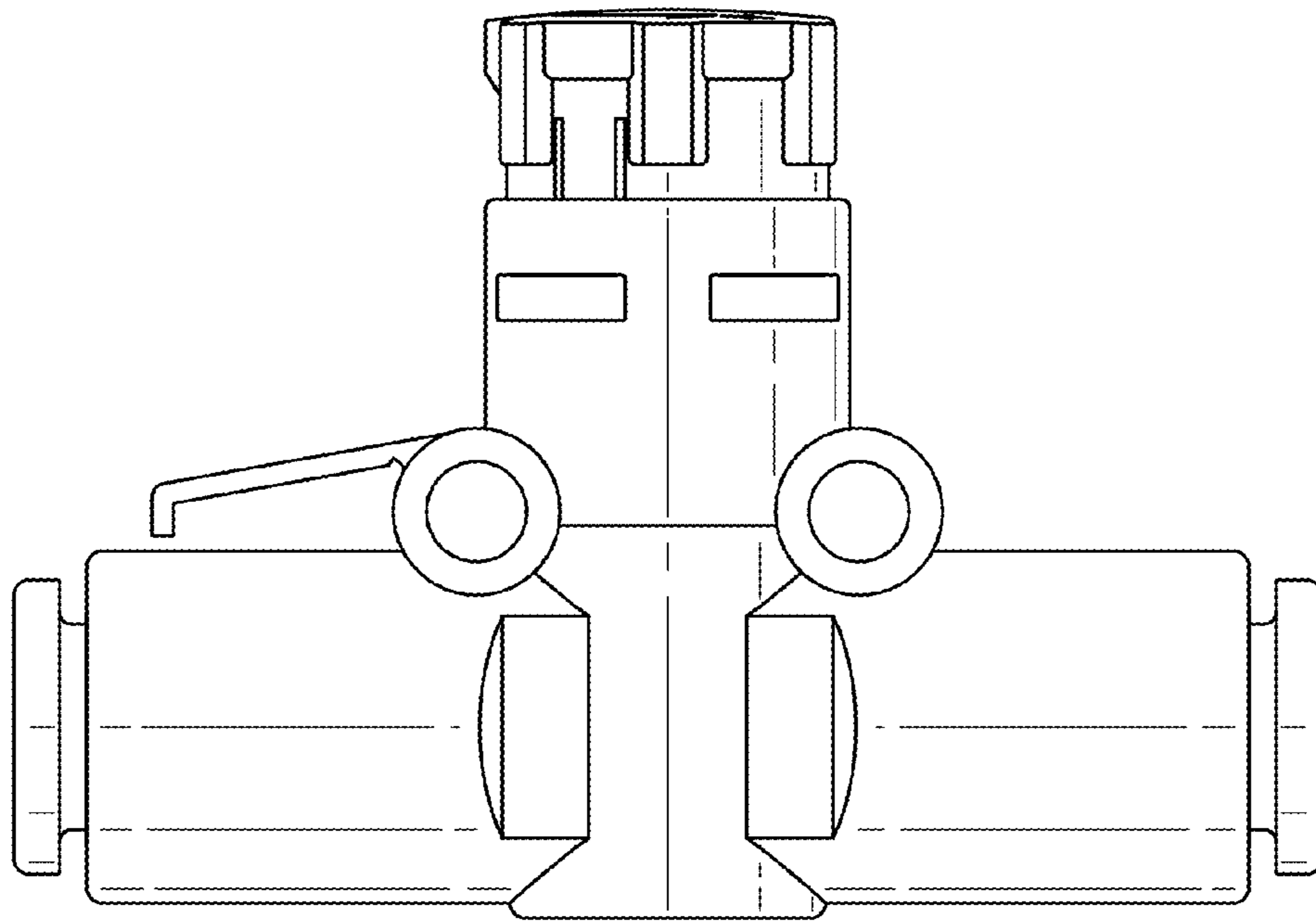

FIG. 17

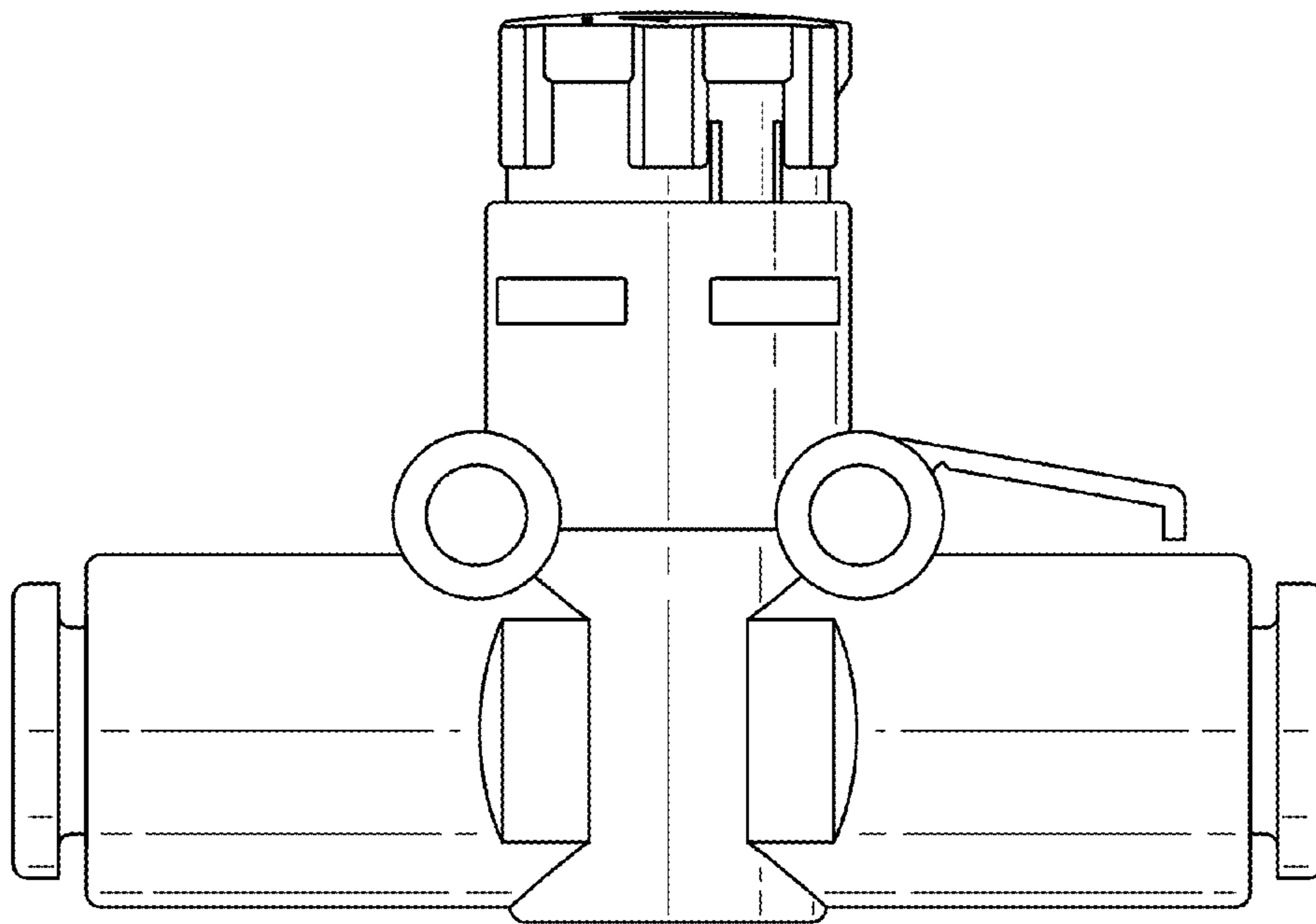

FIG. 18

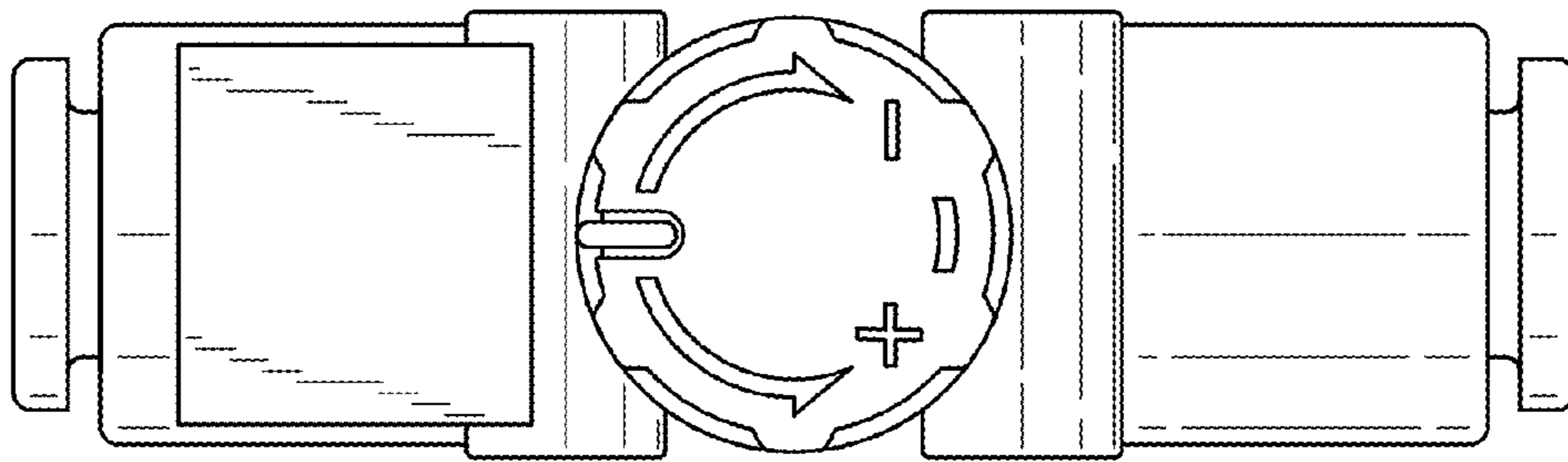

FIG. 19

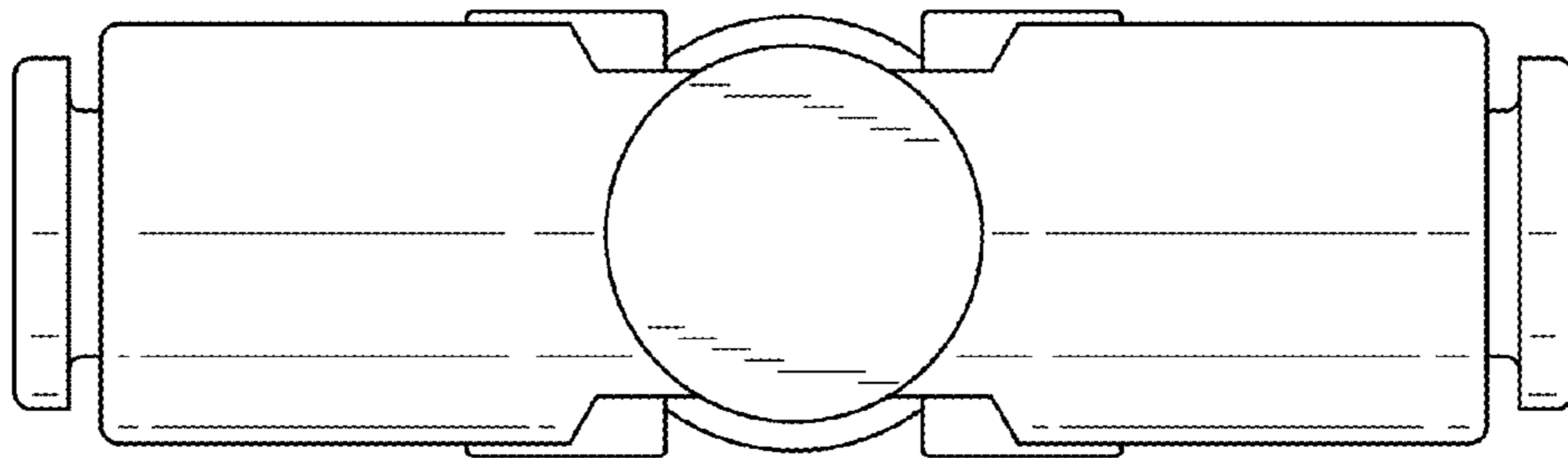

FIG. 20

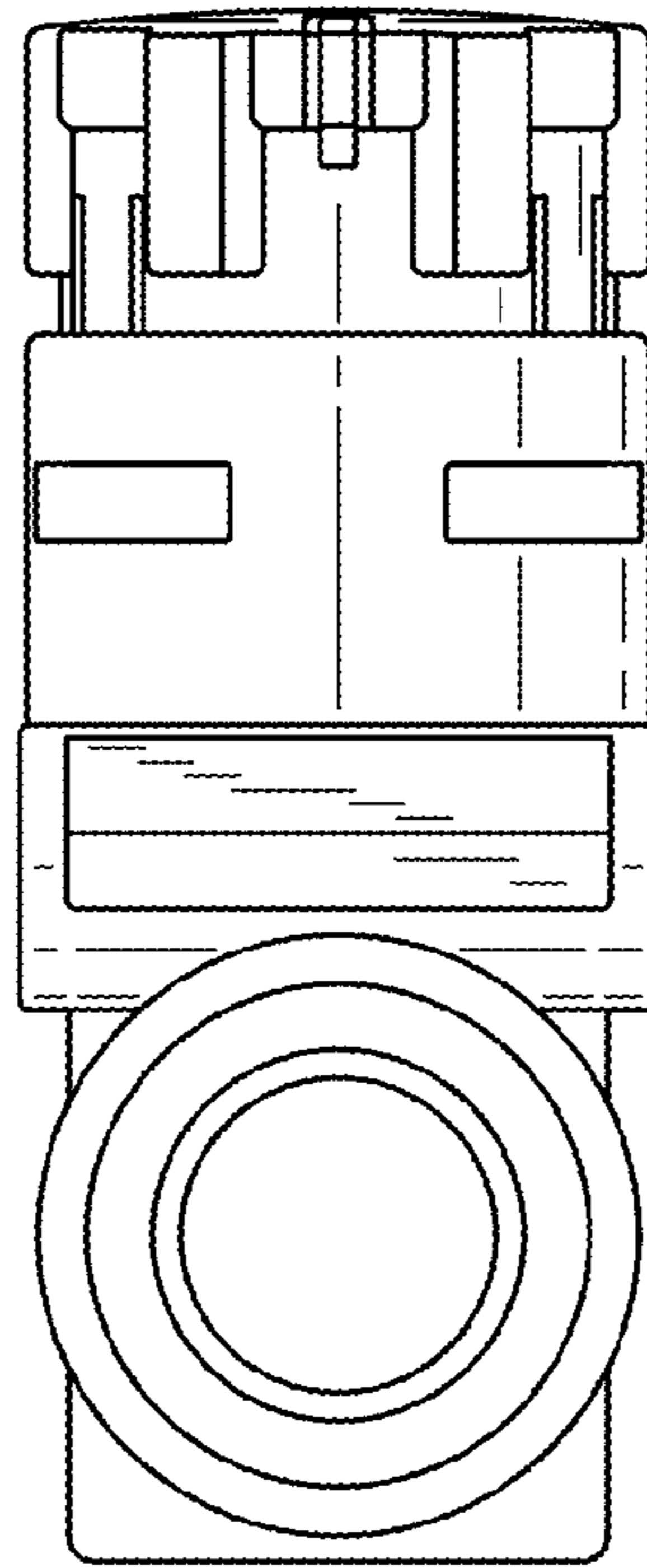

FIG. 21

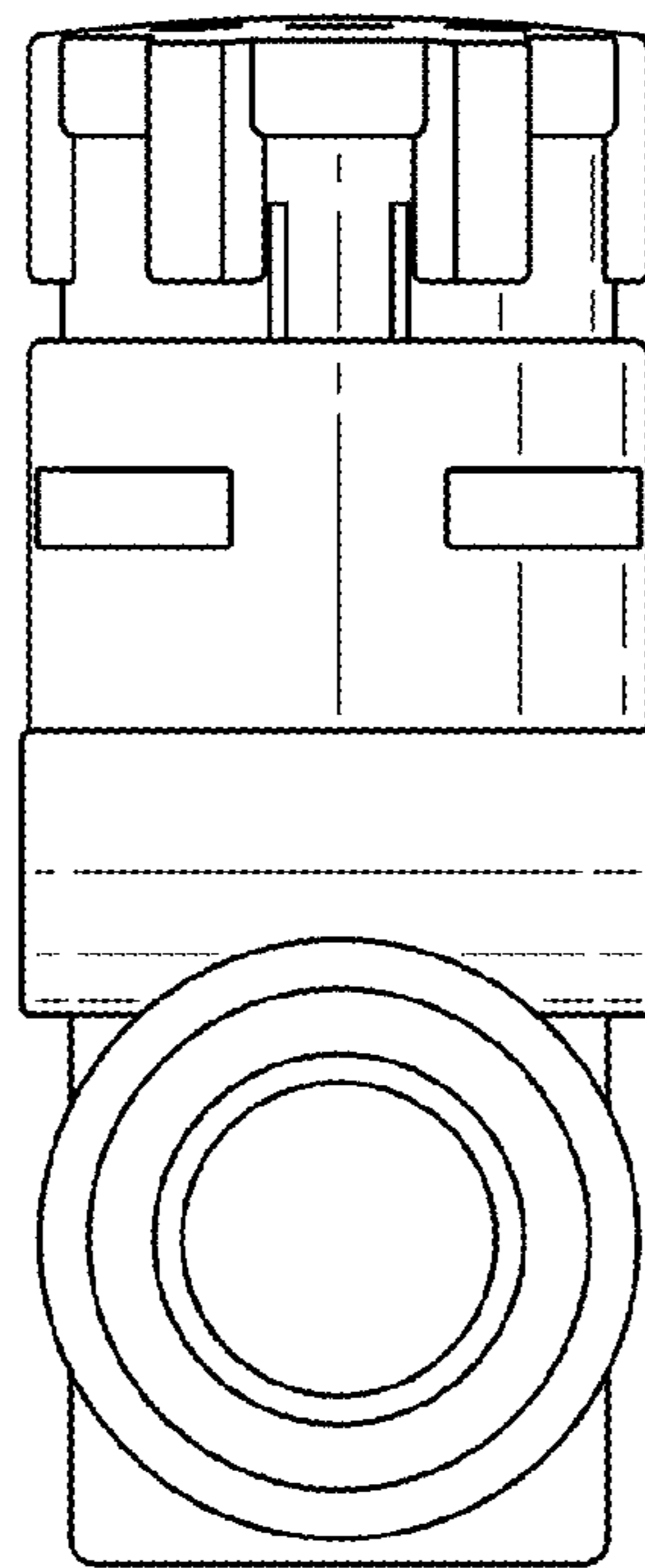

FIG. 22

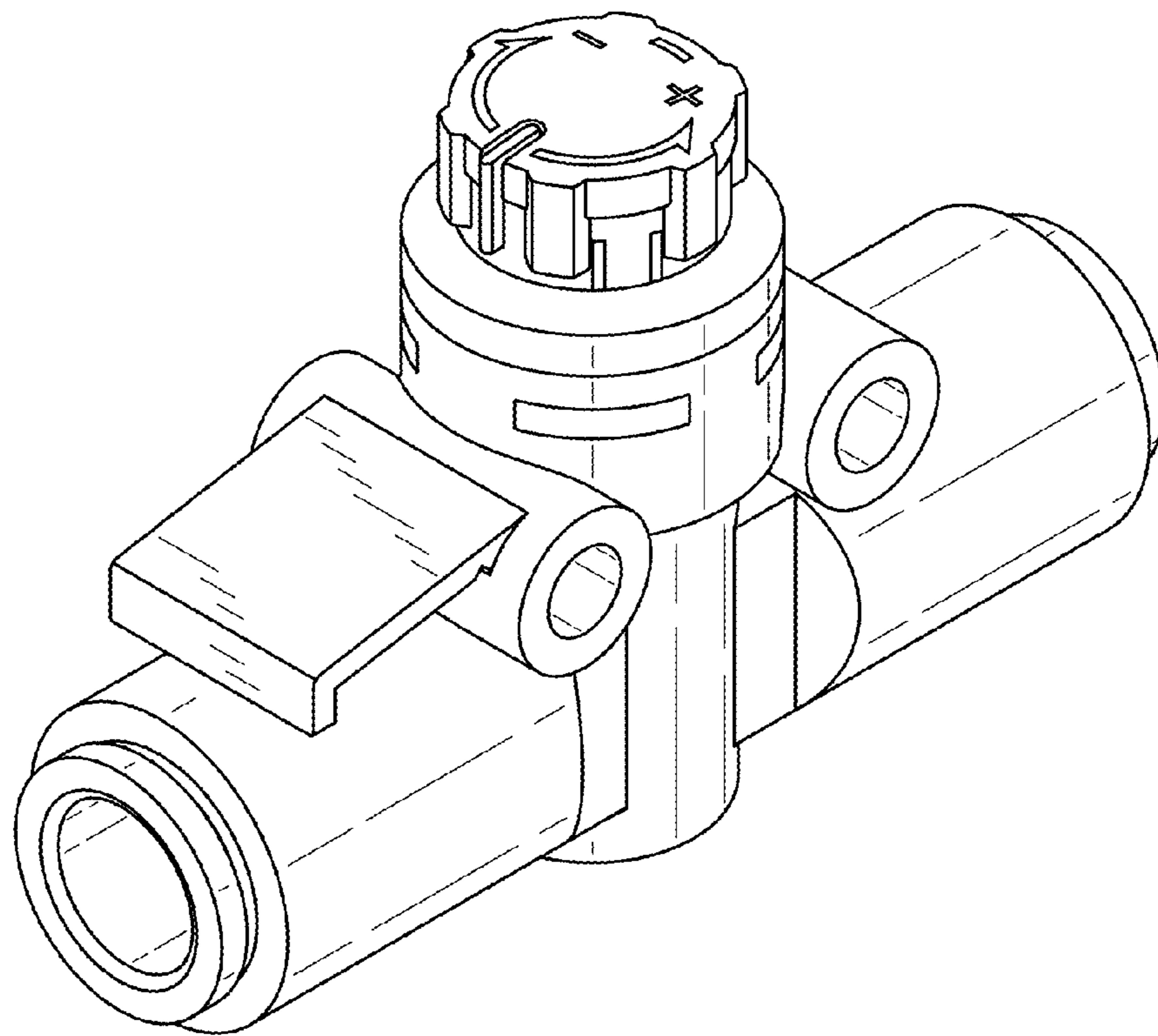

FIG. 23

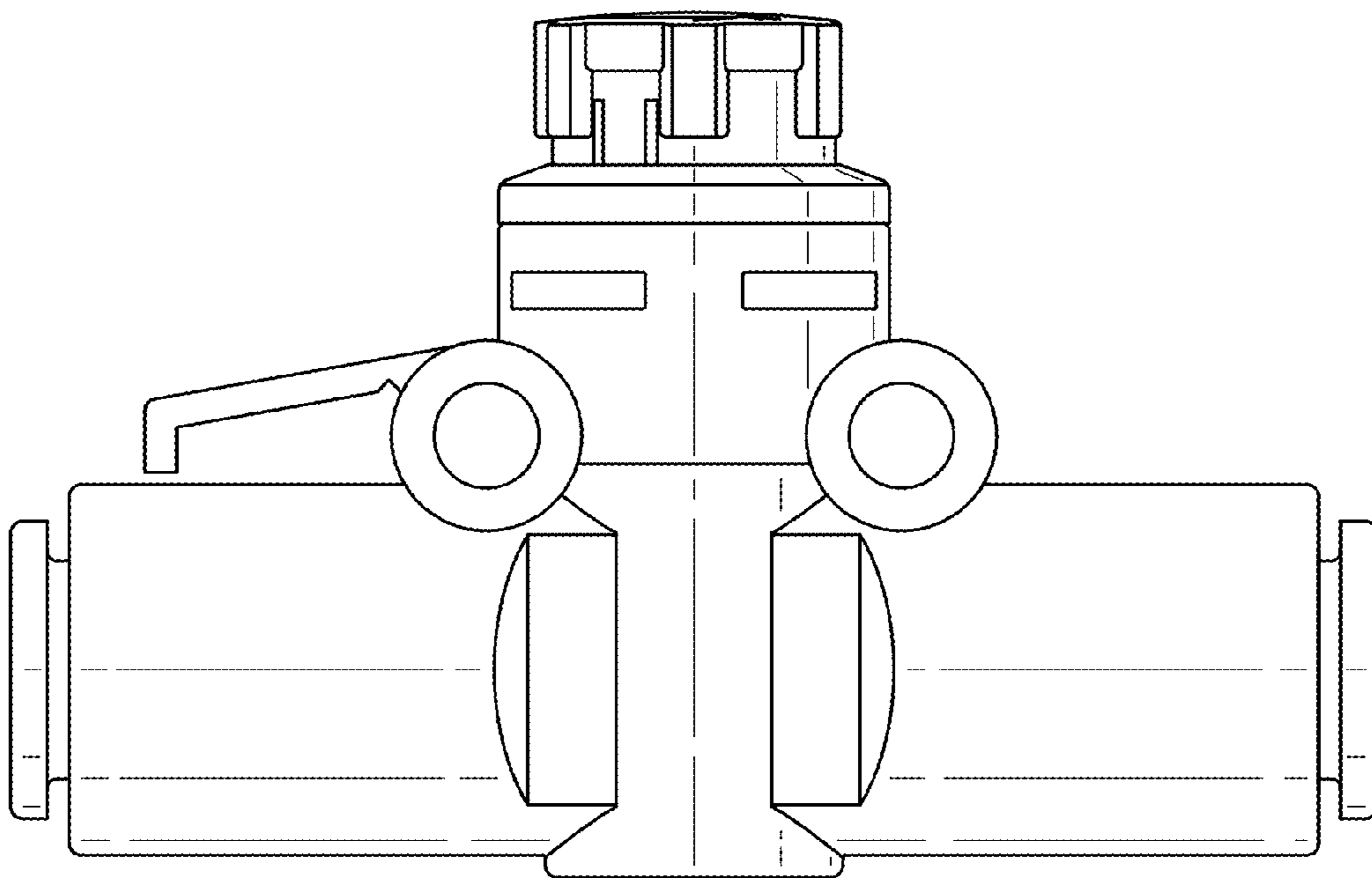

FIG. 24

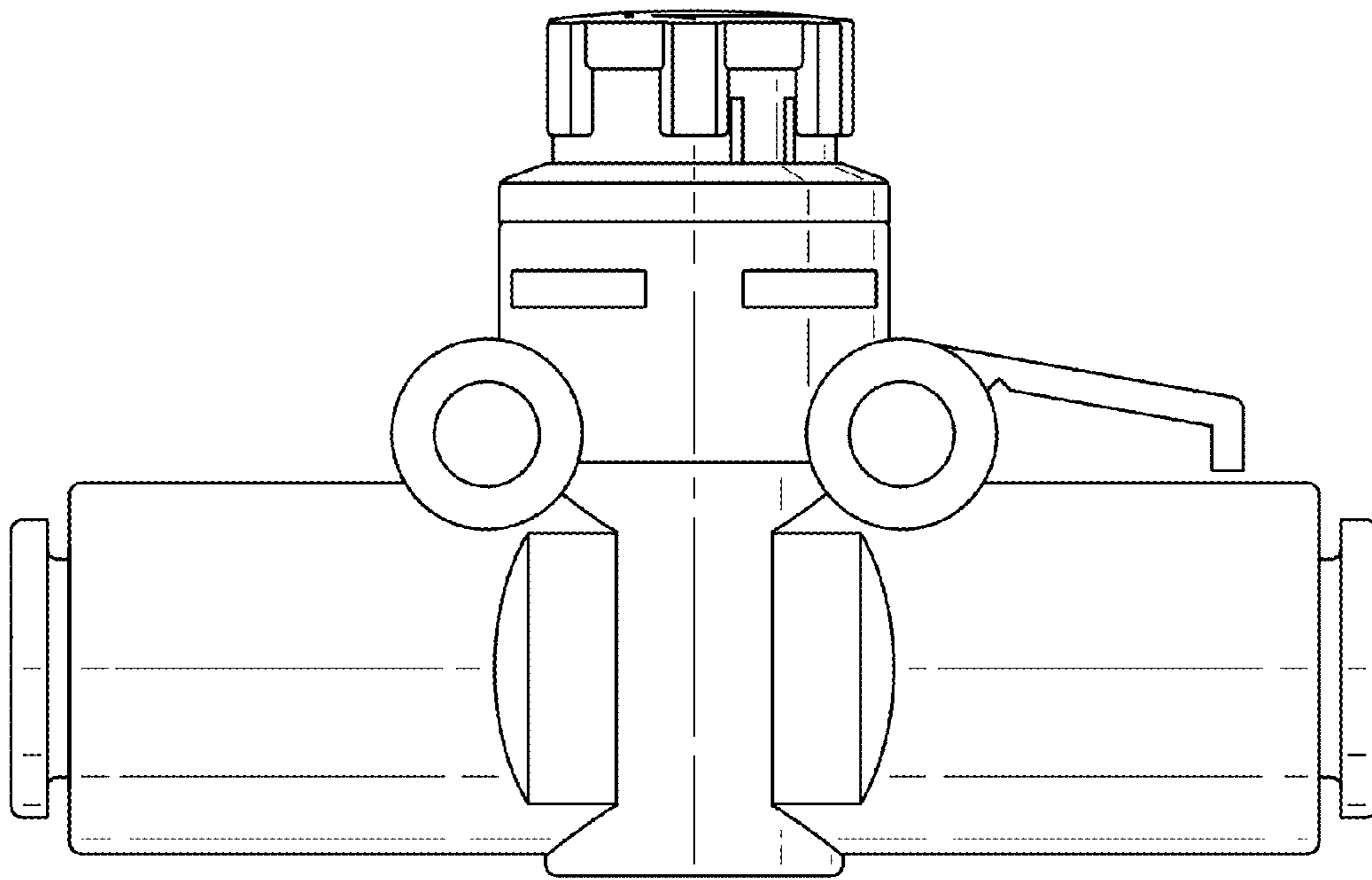

FIG. 25

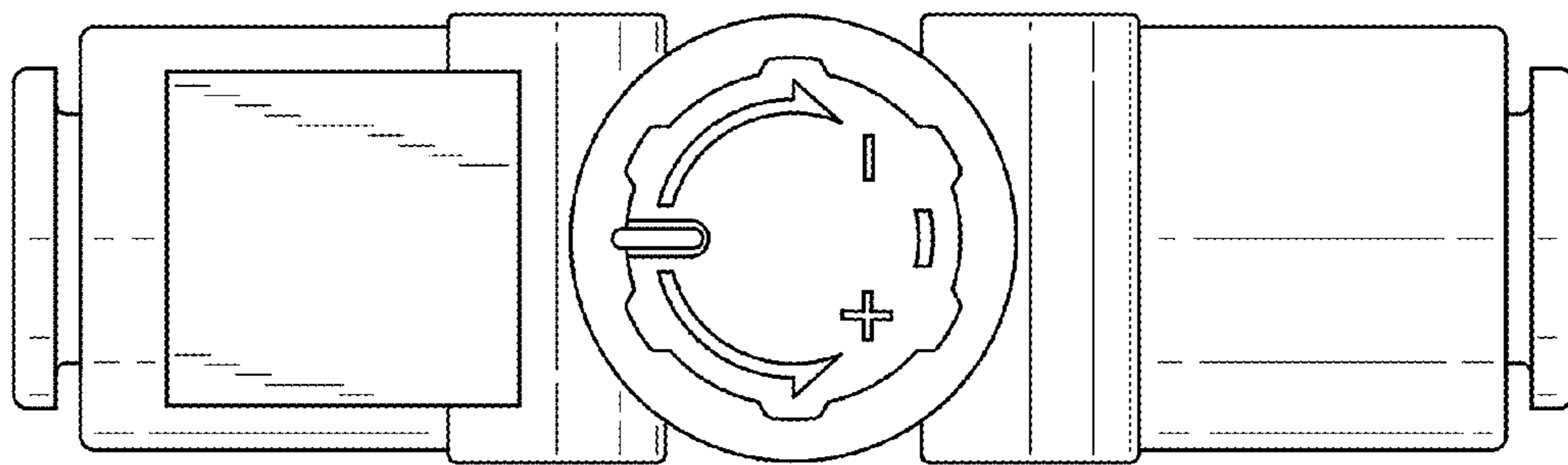

FIG. 26

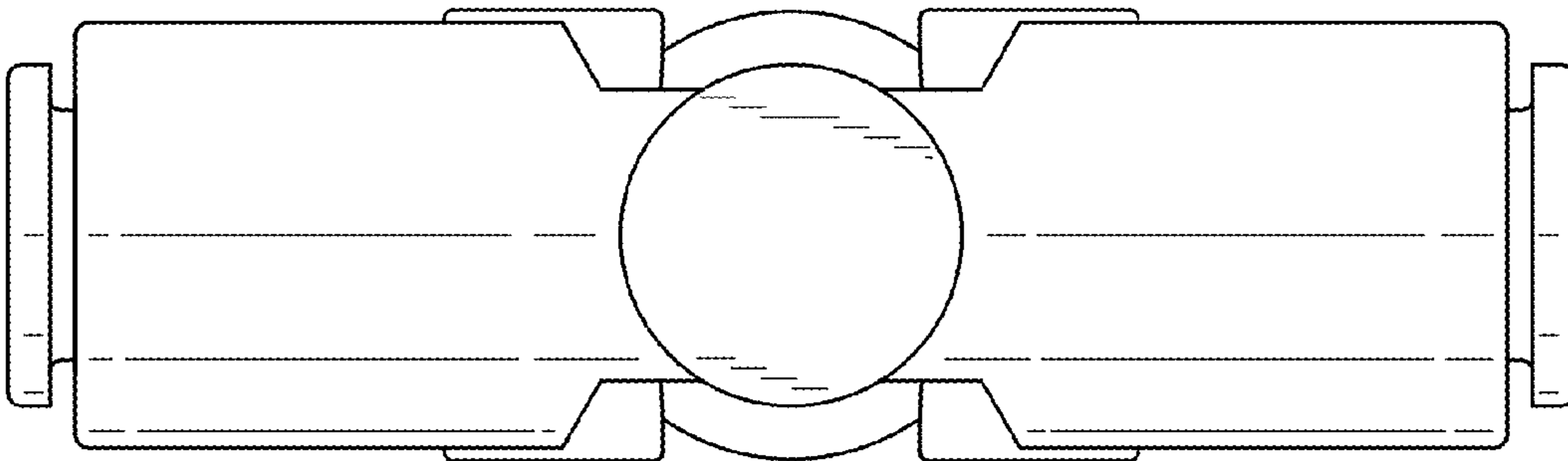

FIG. 27

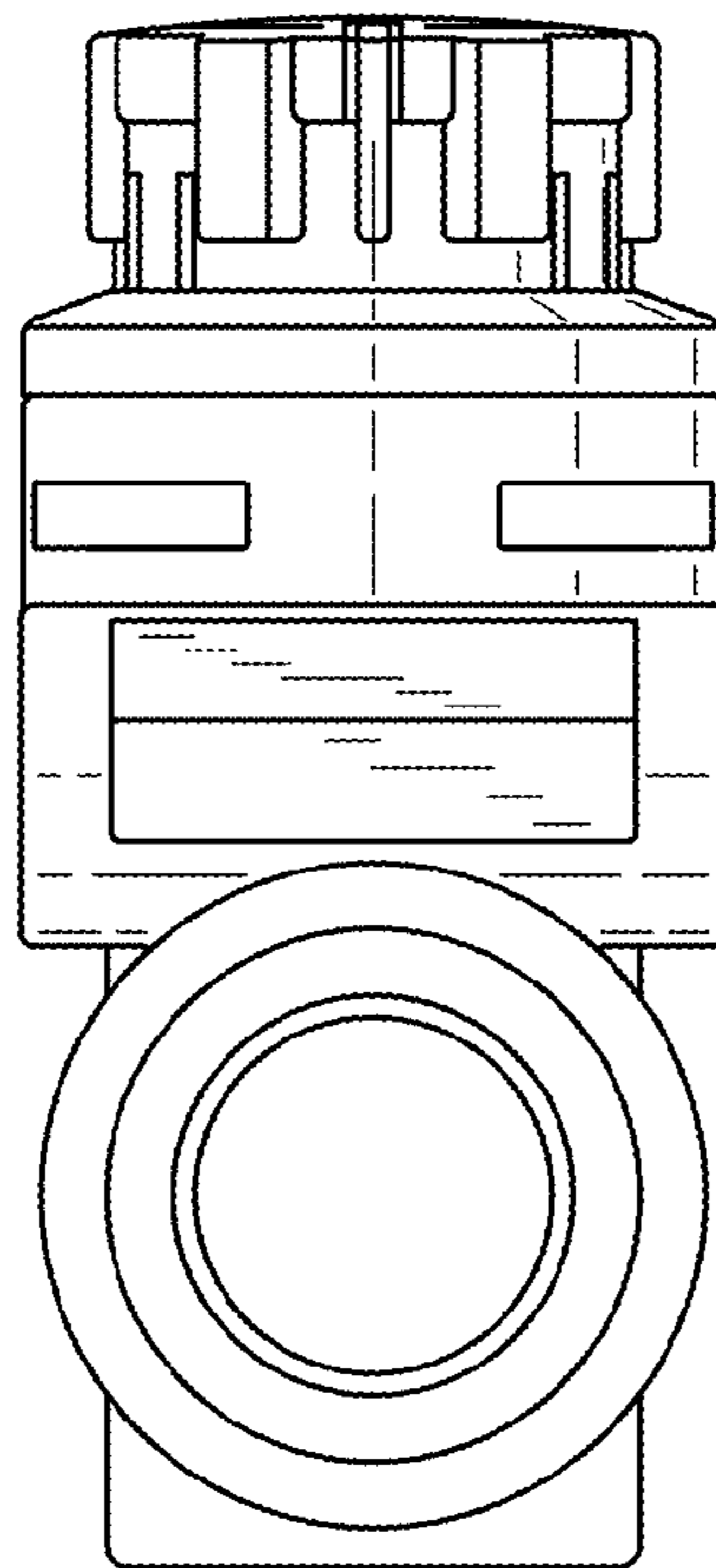

FIG. 28

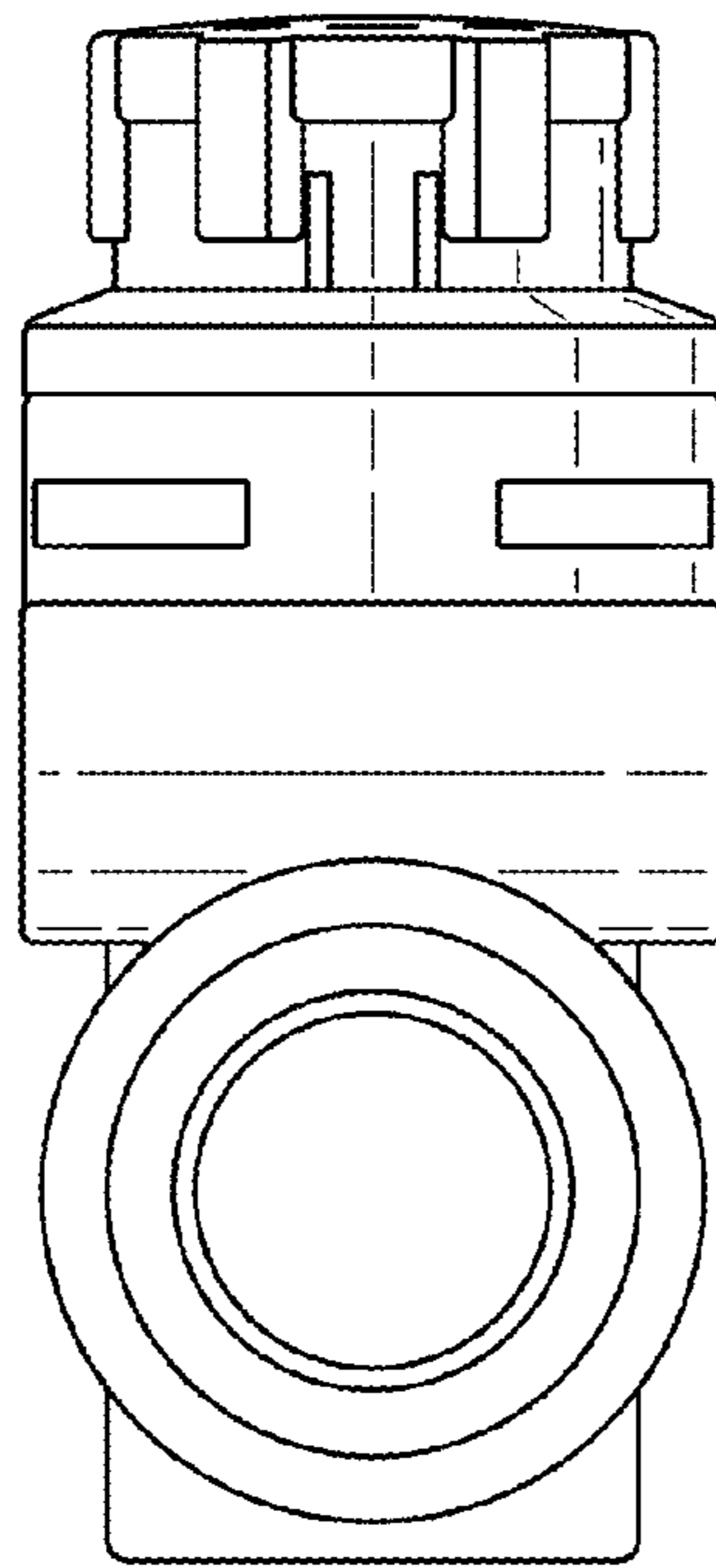

FIG. 29

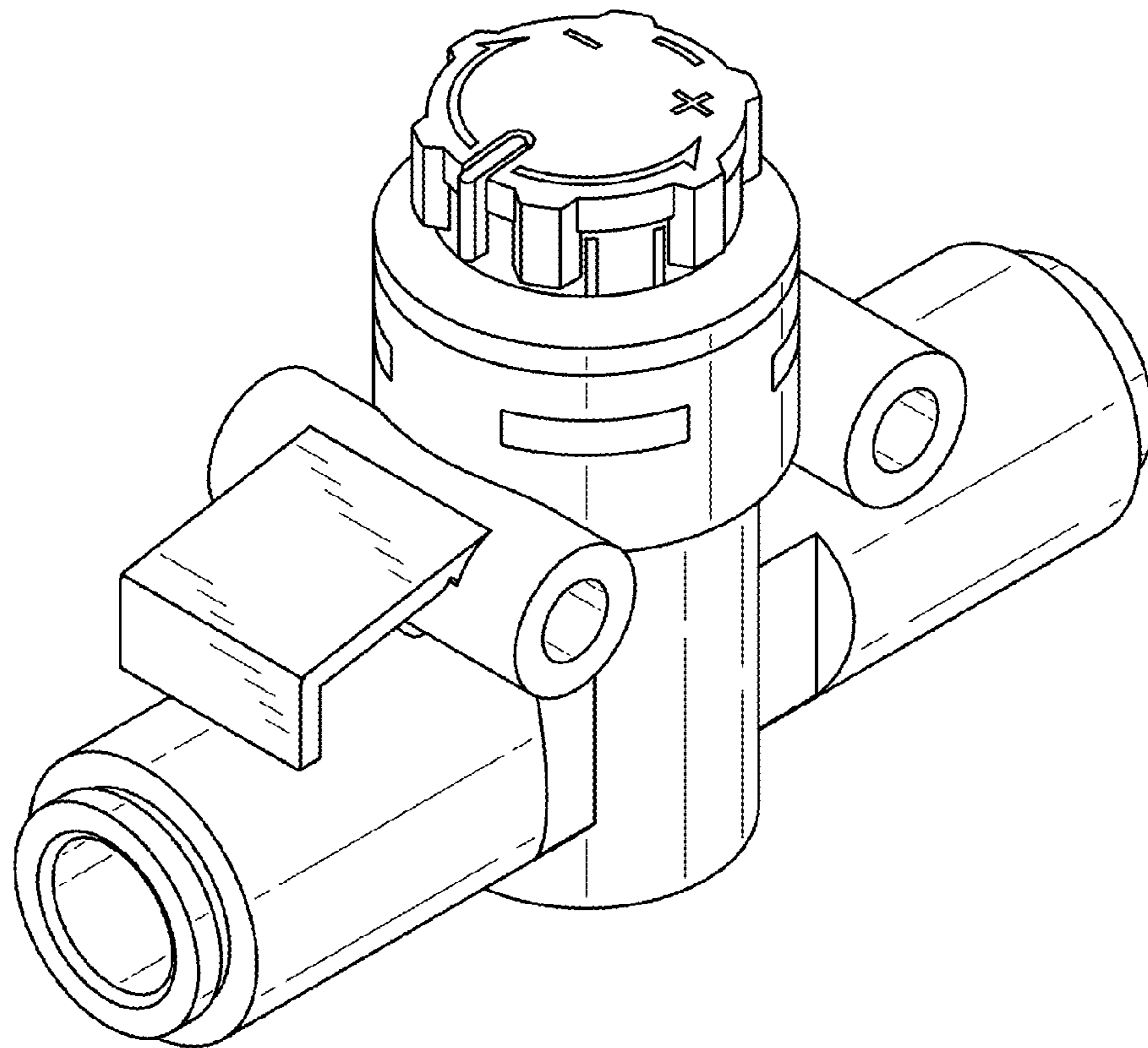

FIG. 30

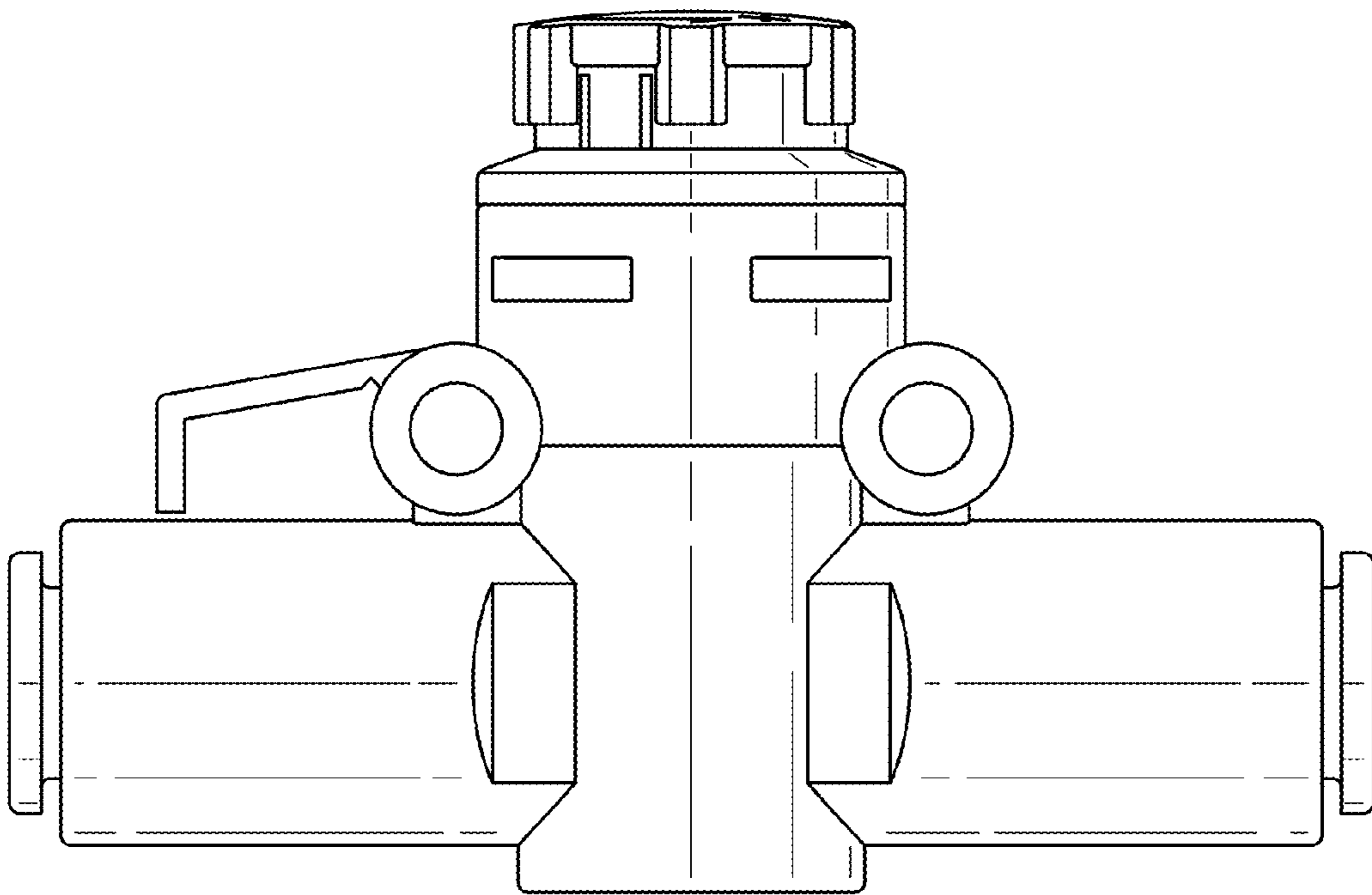

FIG. 31

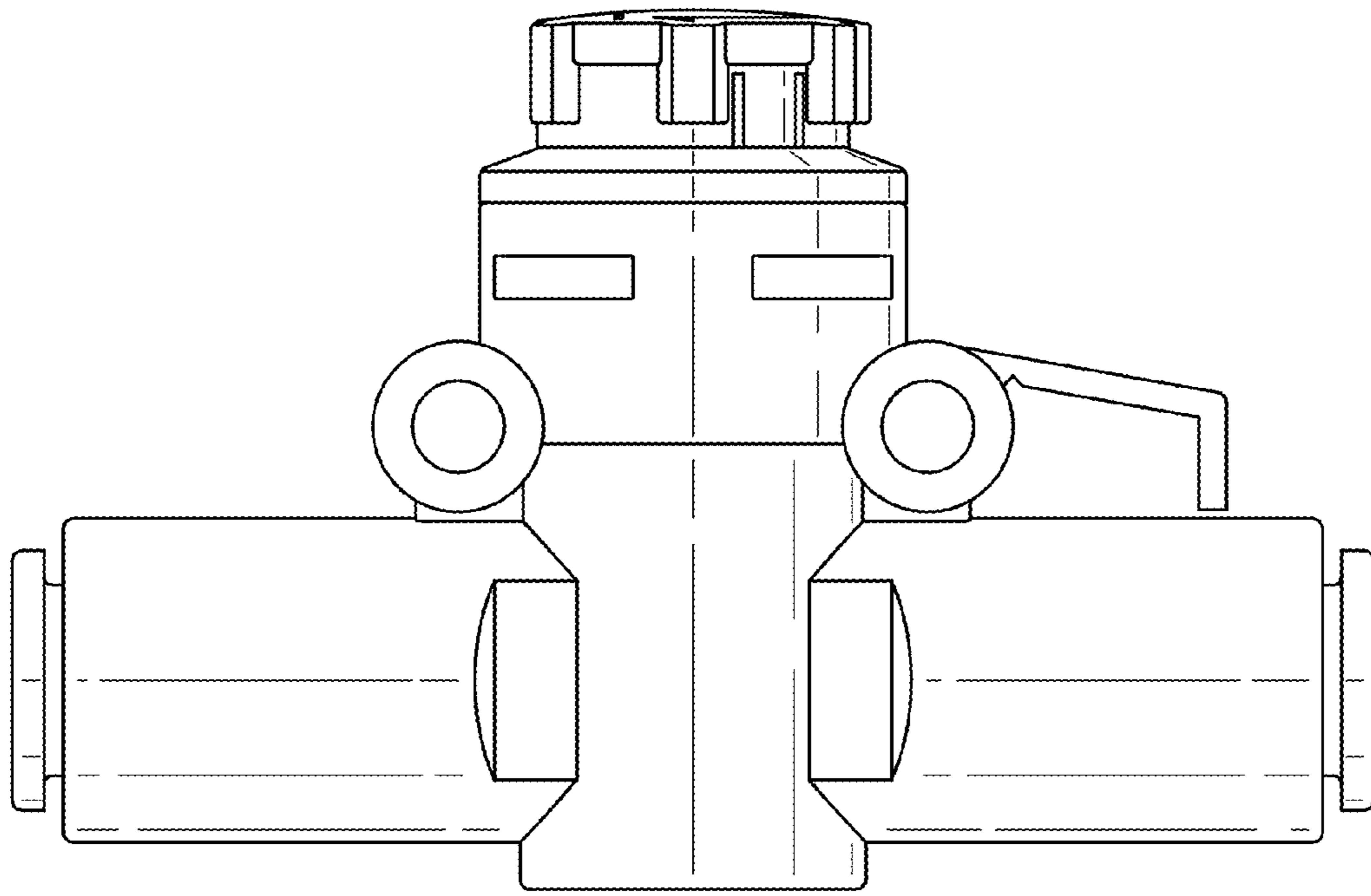

FIG. 32

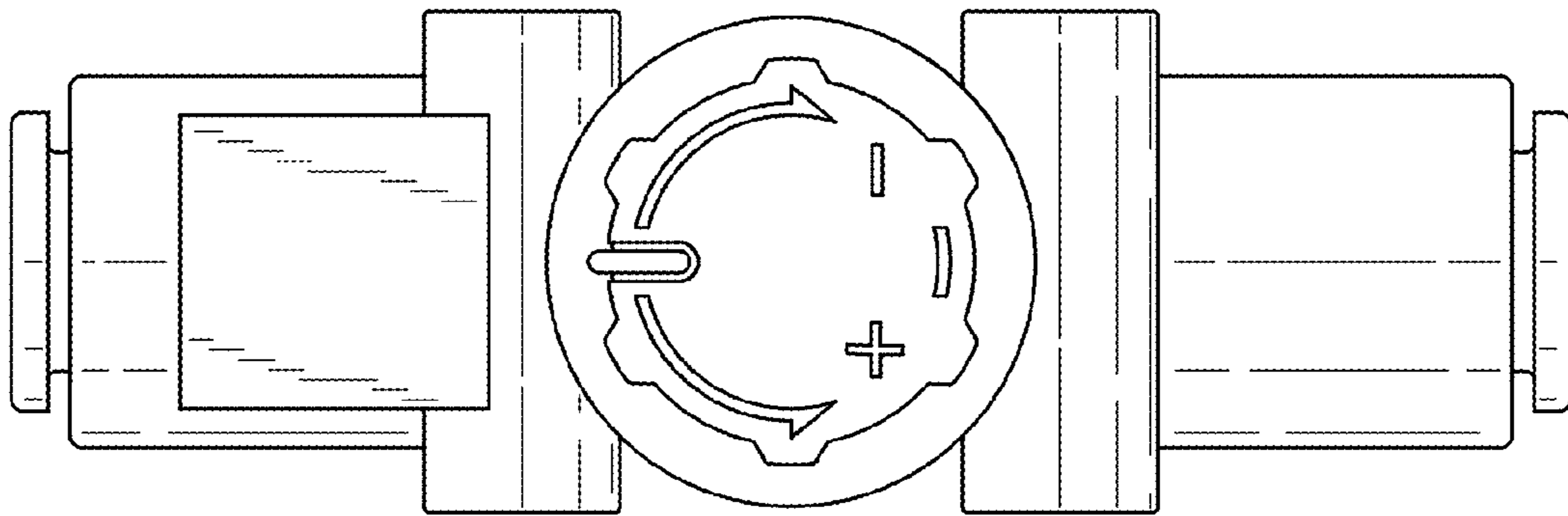

FIG. 33

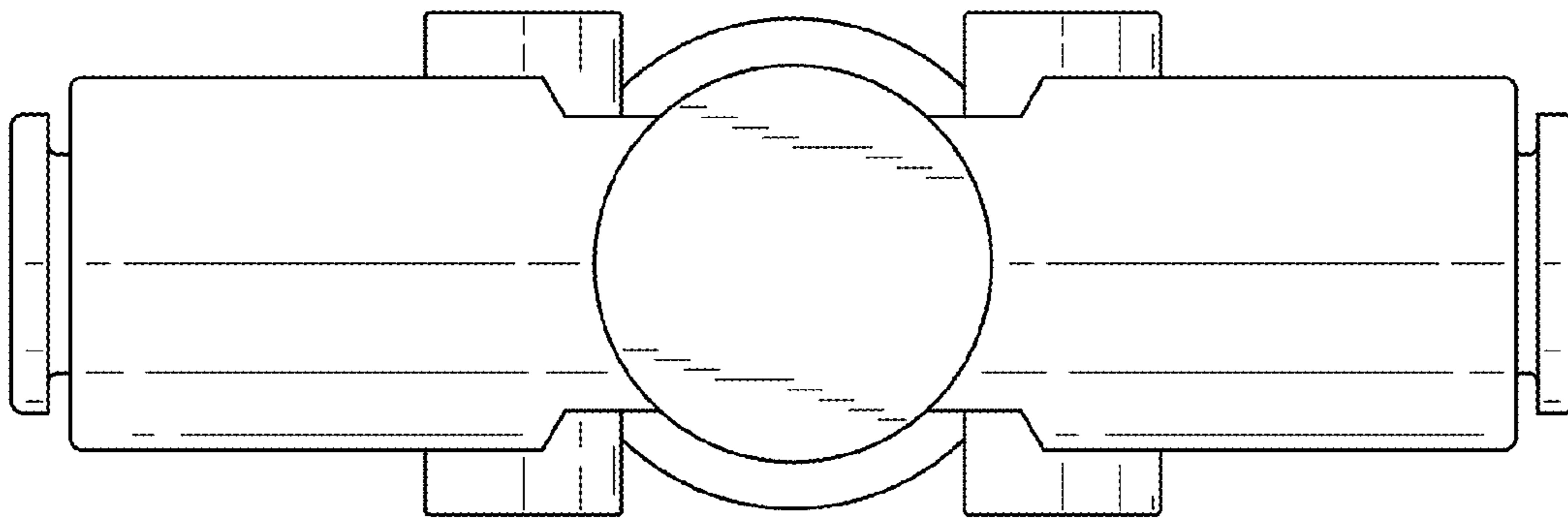

FIG. 34

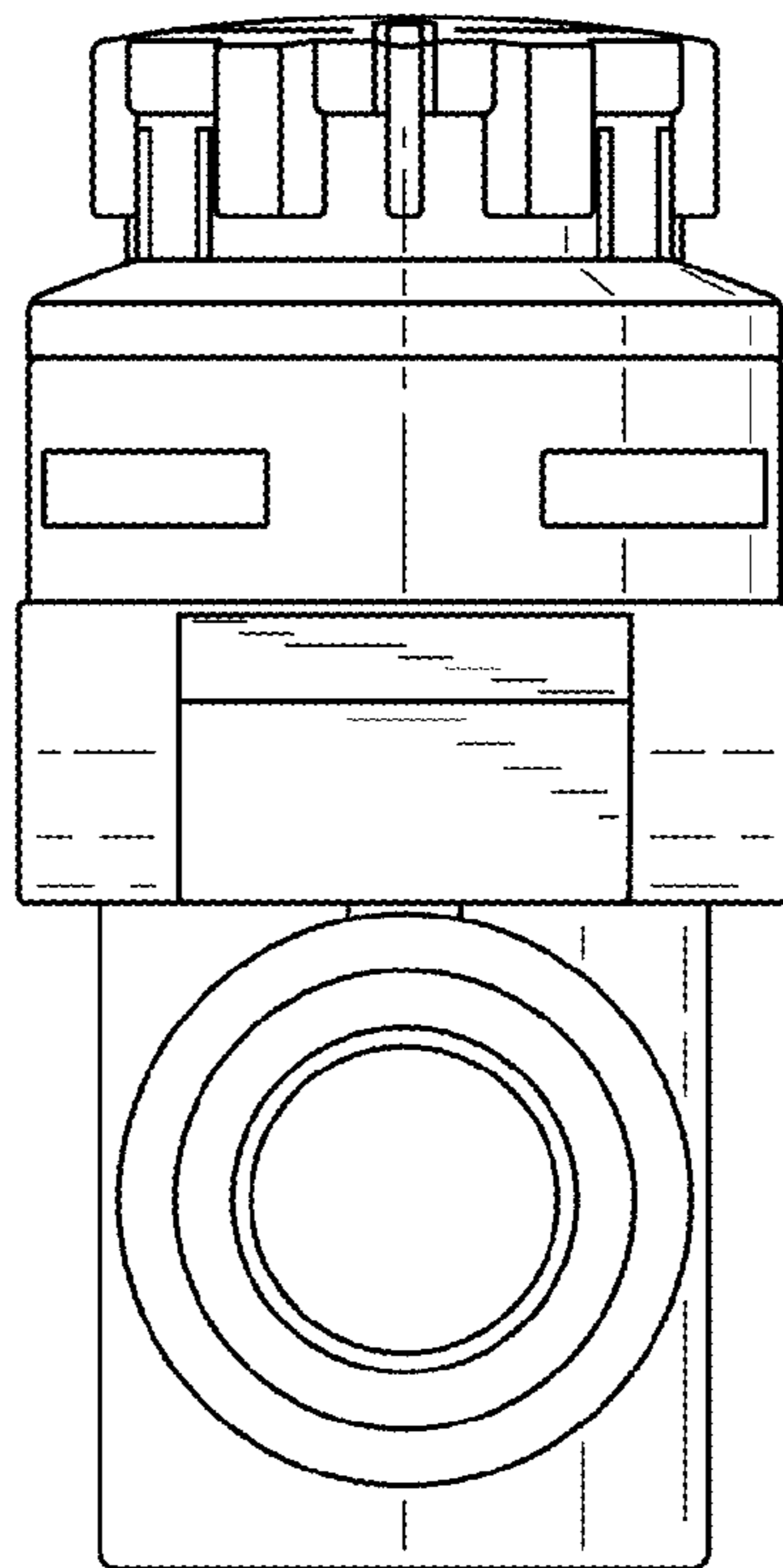

FIG. 35

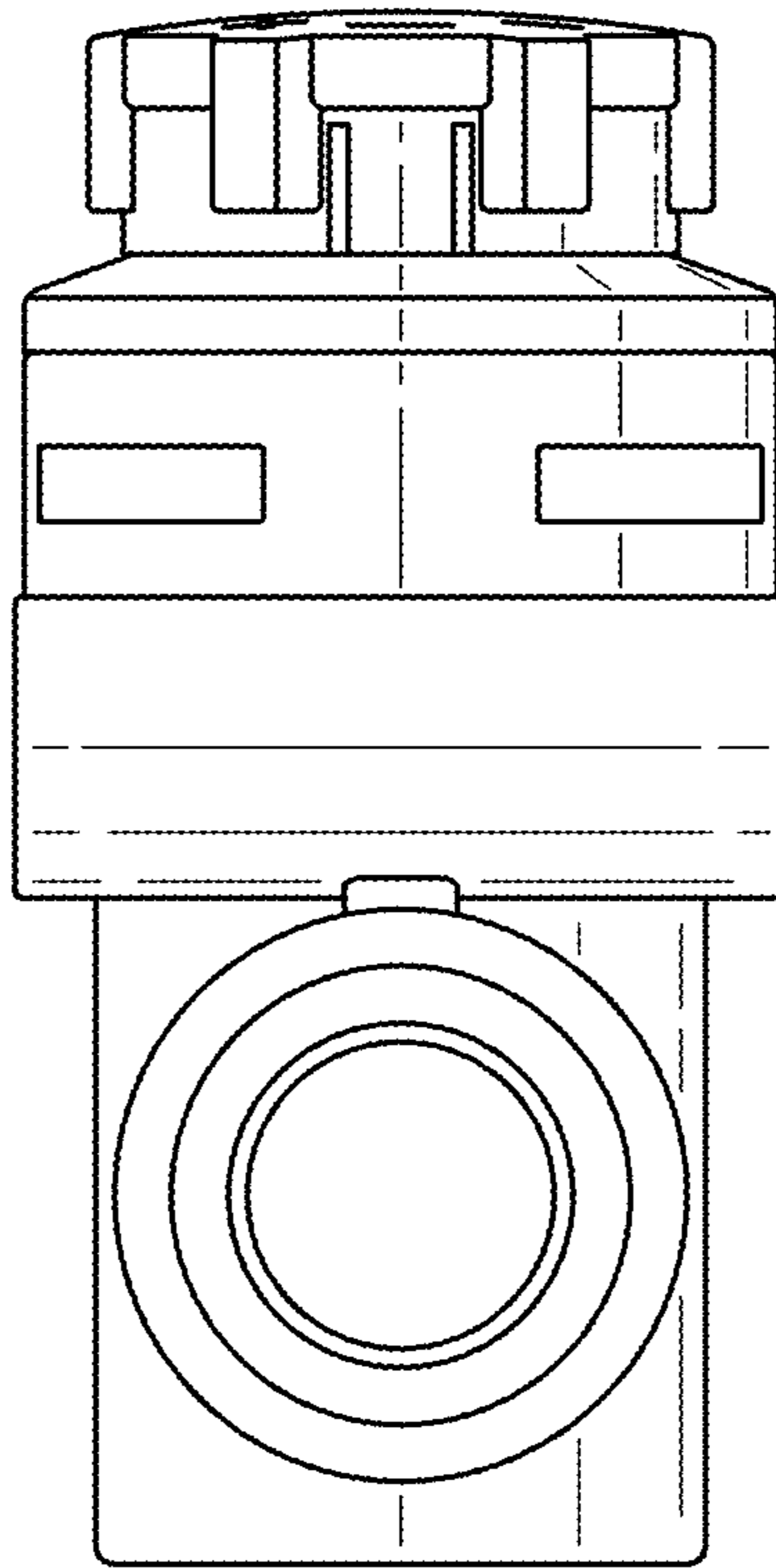

FIG. 36

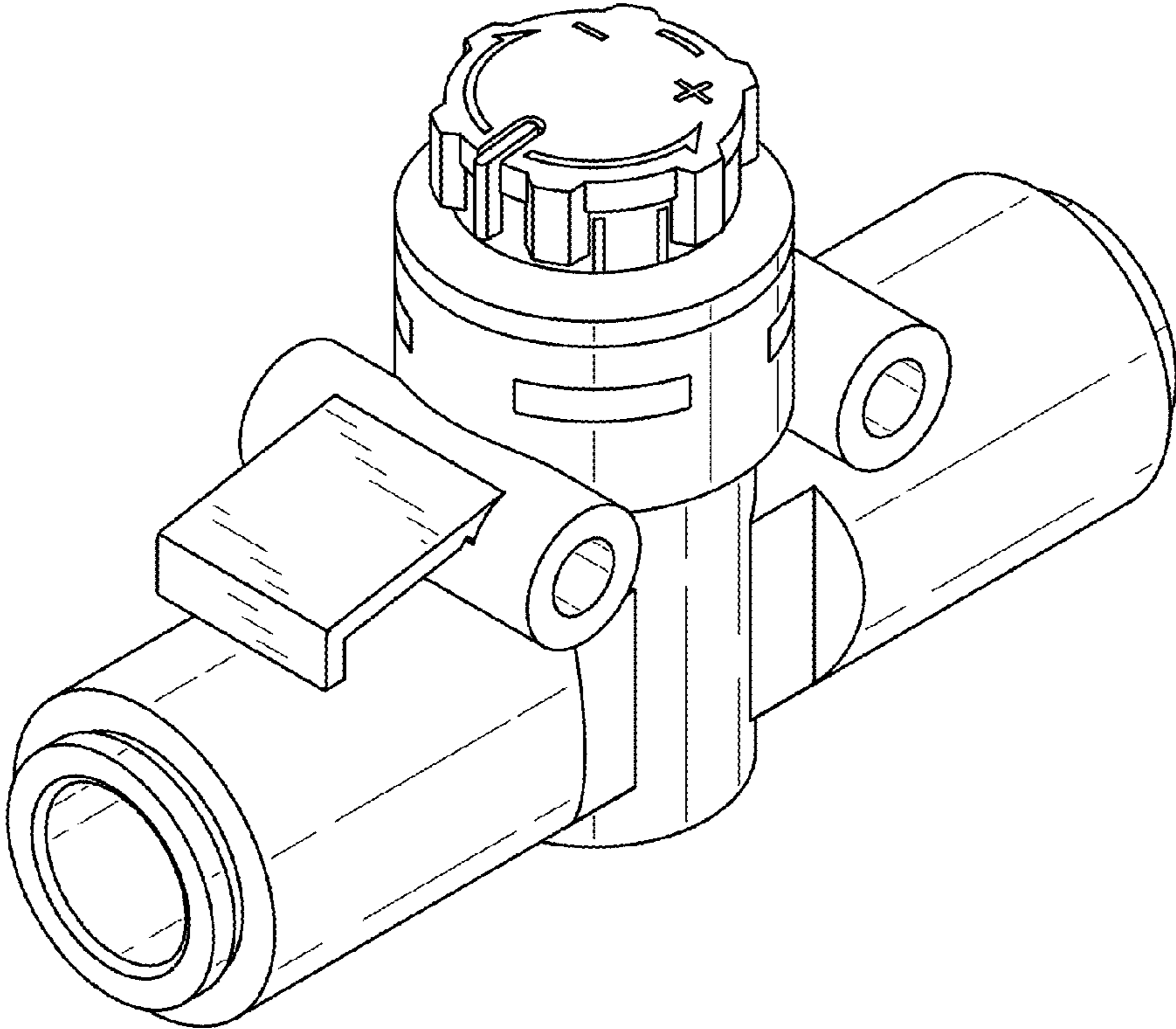

FIG. 37

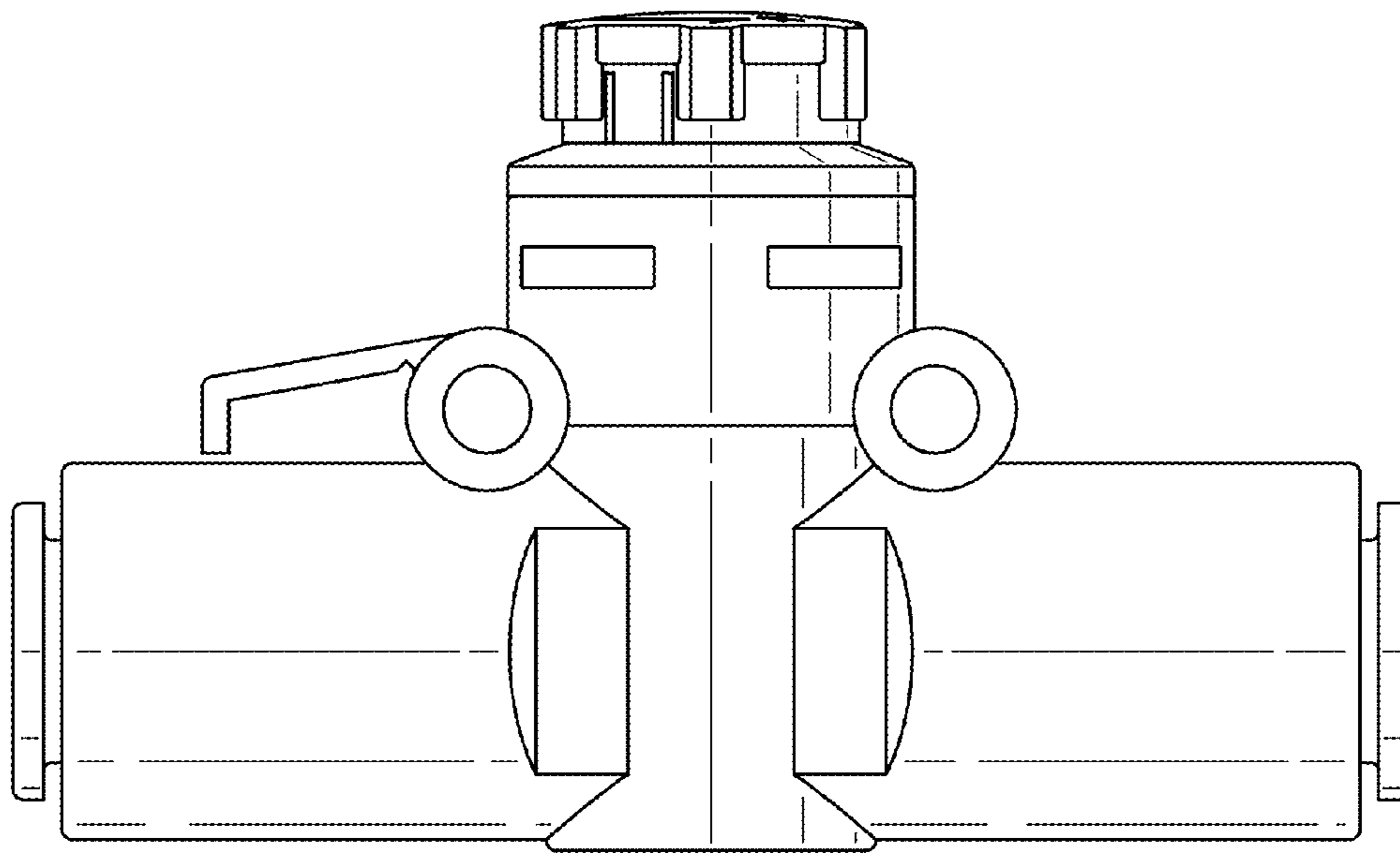

FIG. 38

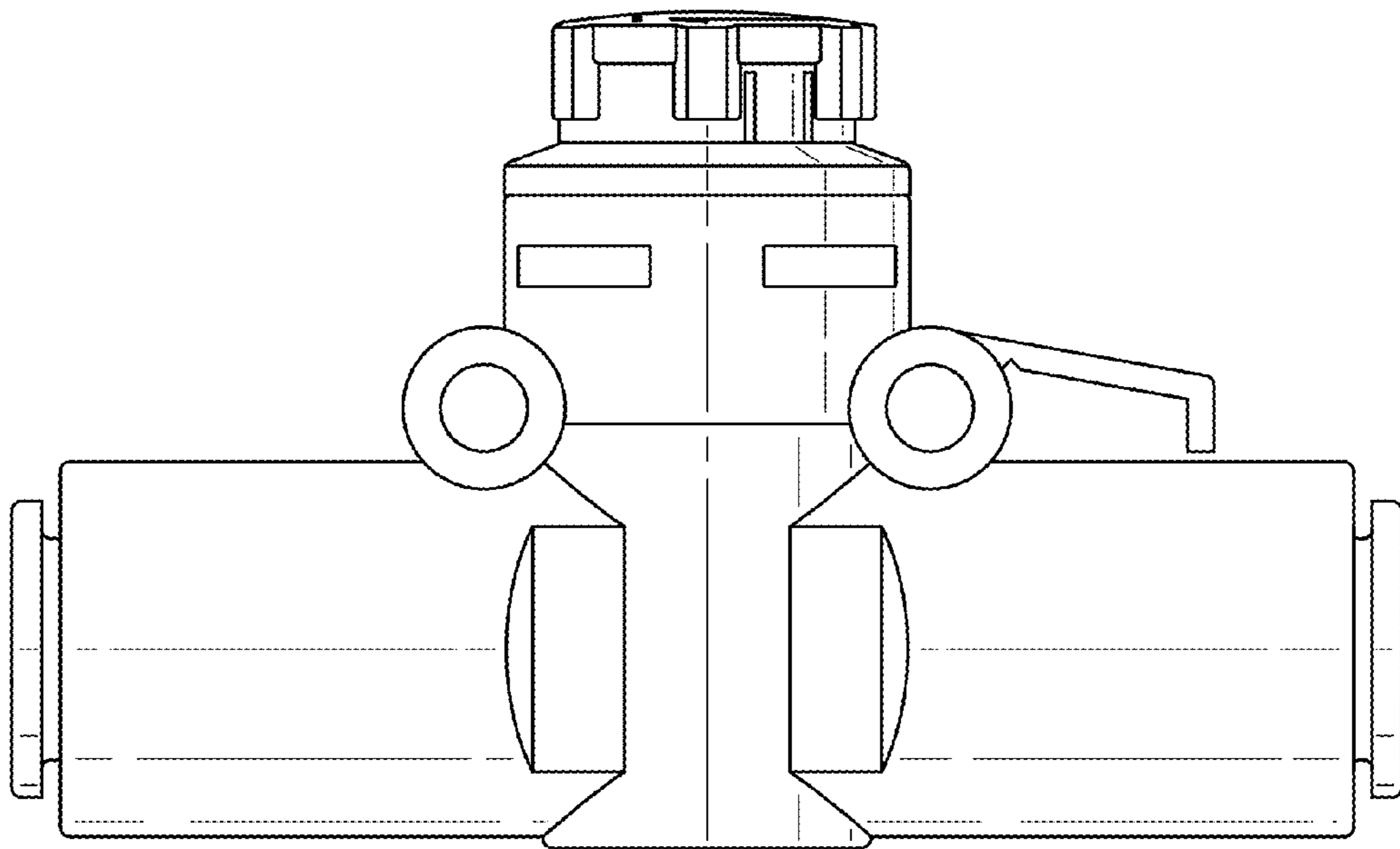

FIG. 39

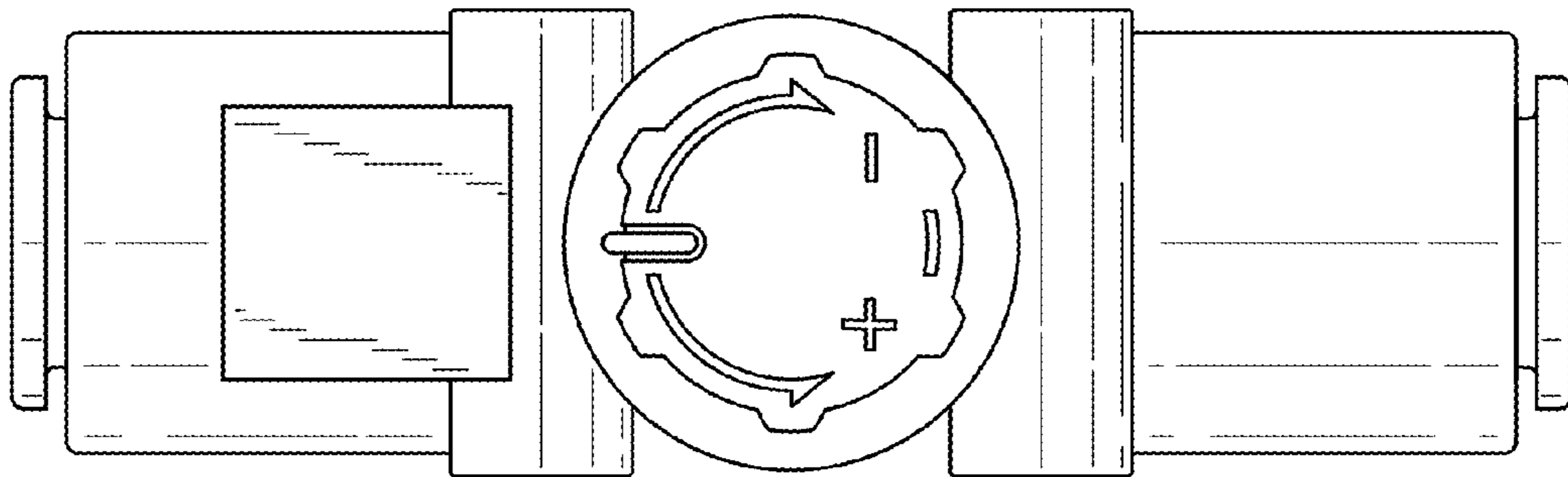

FIG. 40

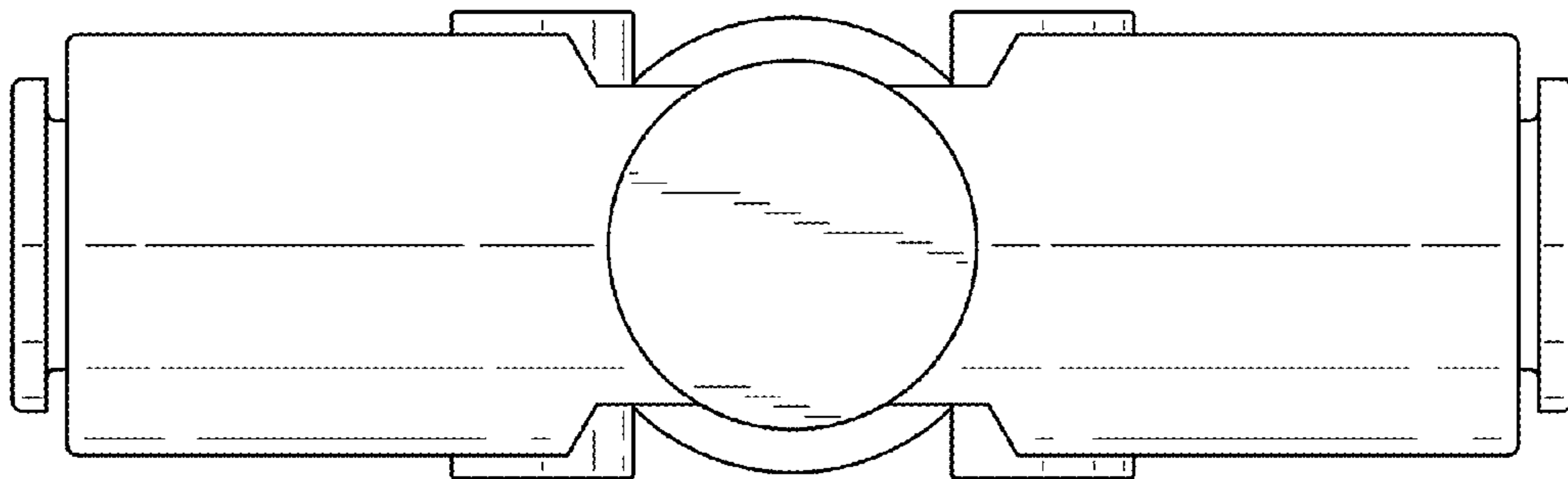

FIG. 41

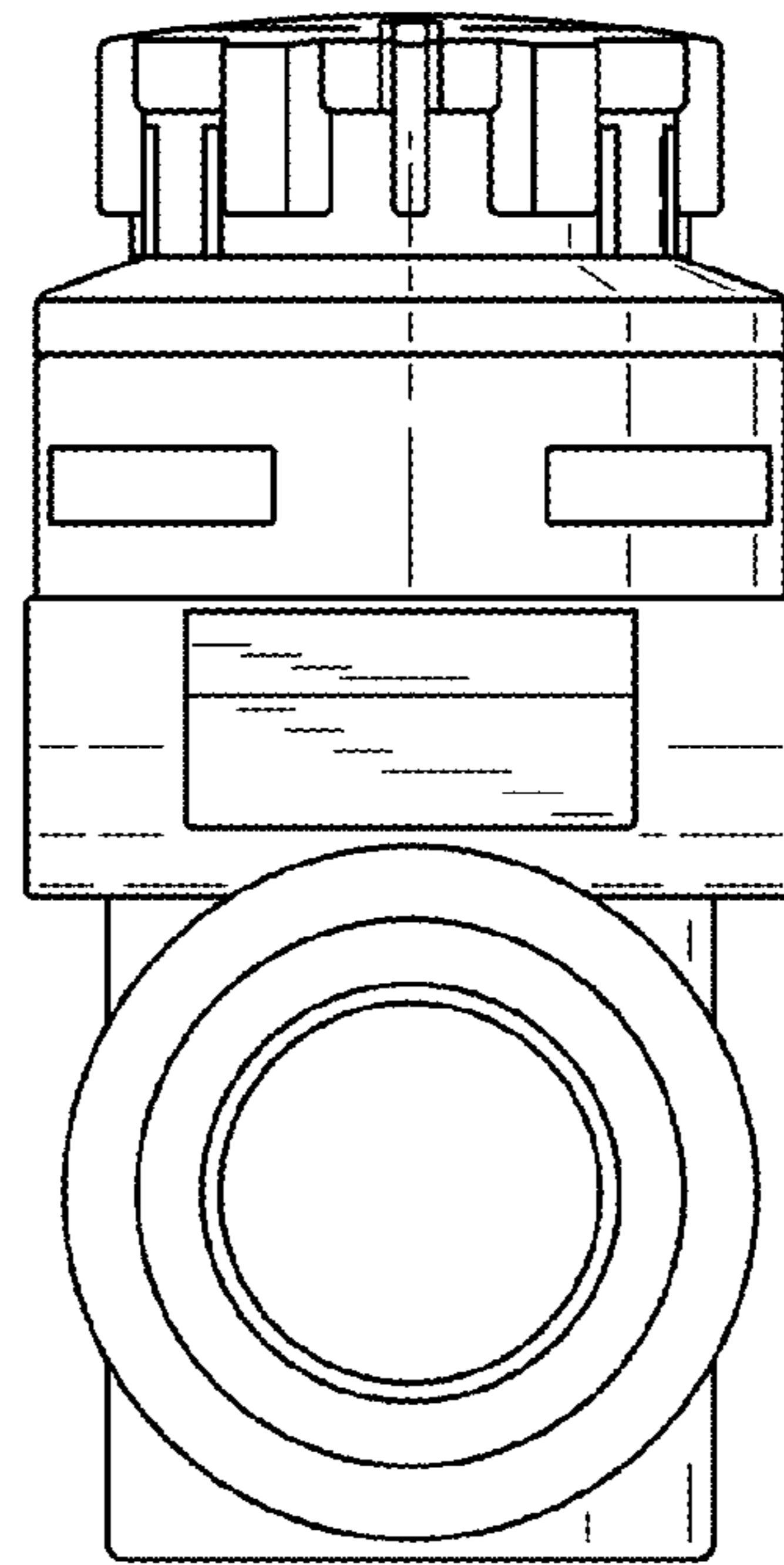

FIG. 42

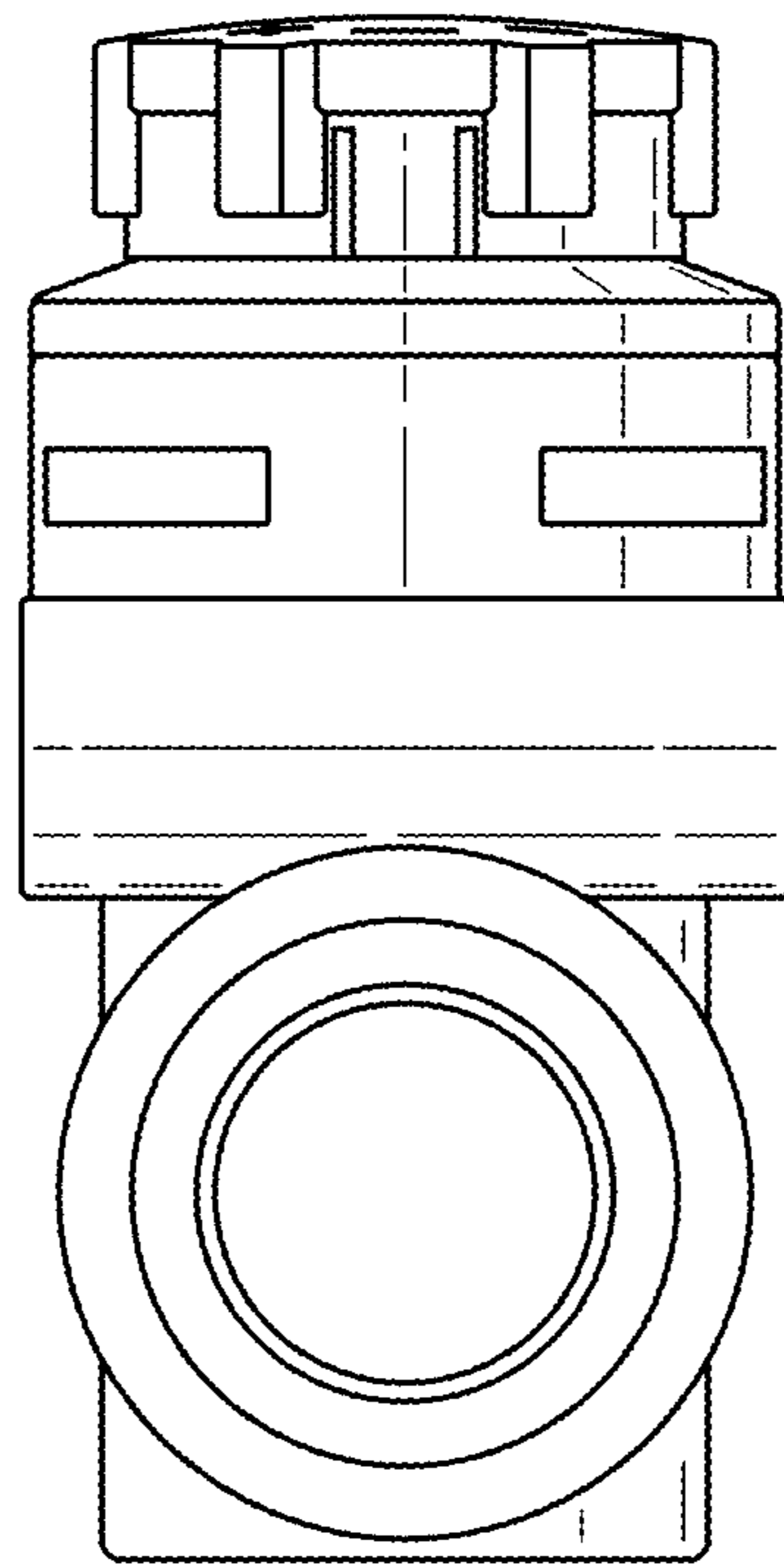

FIG. 43

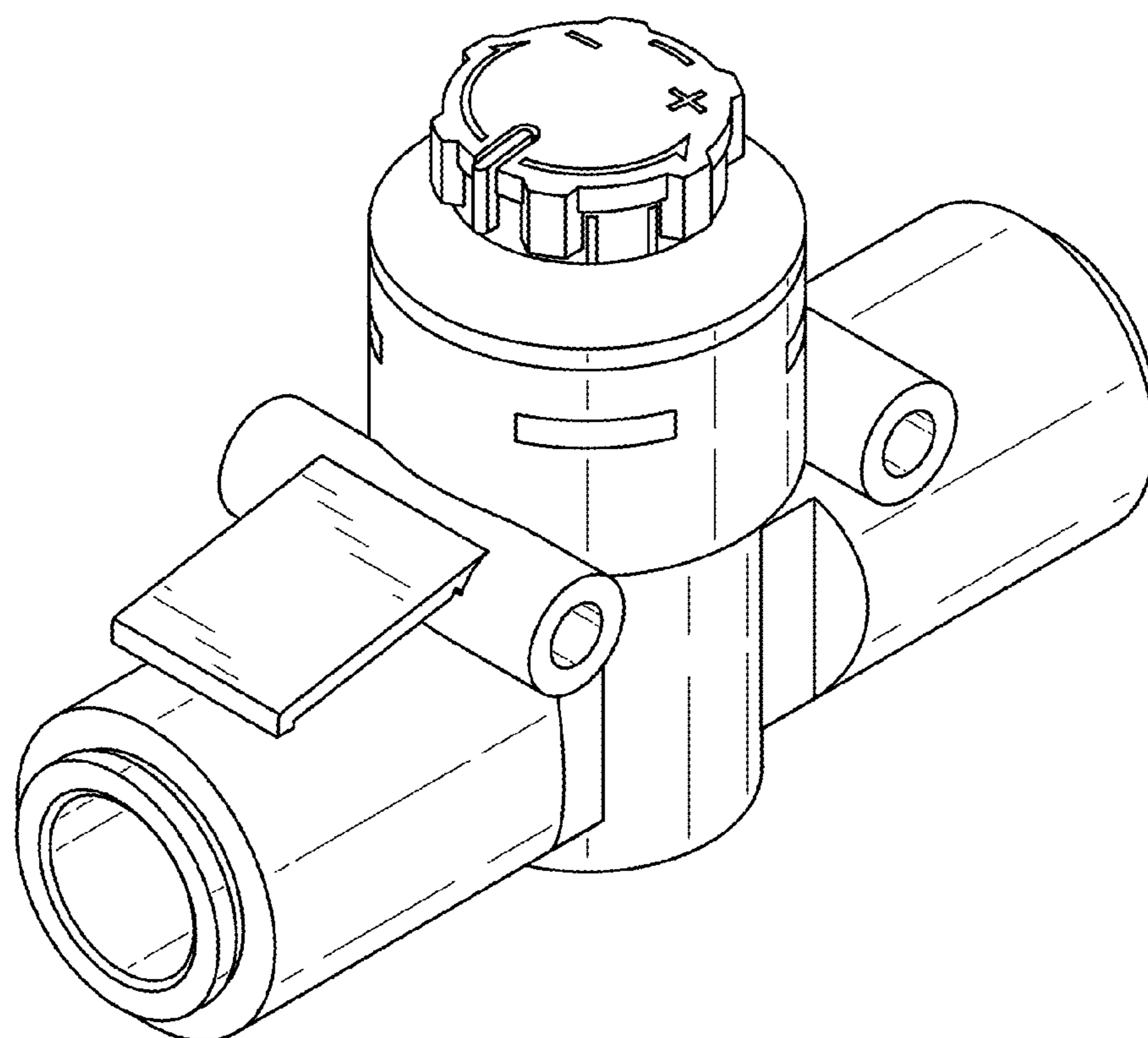

FIG. 44

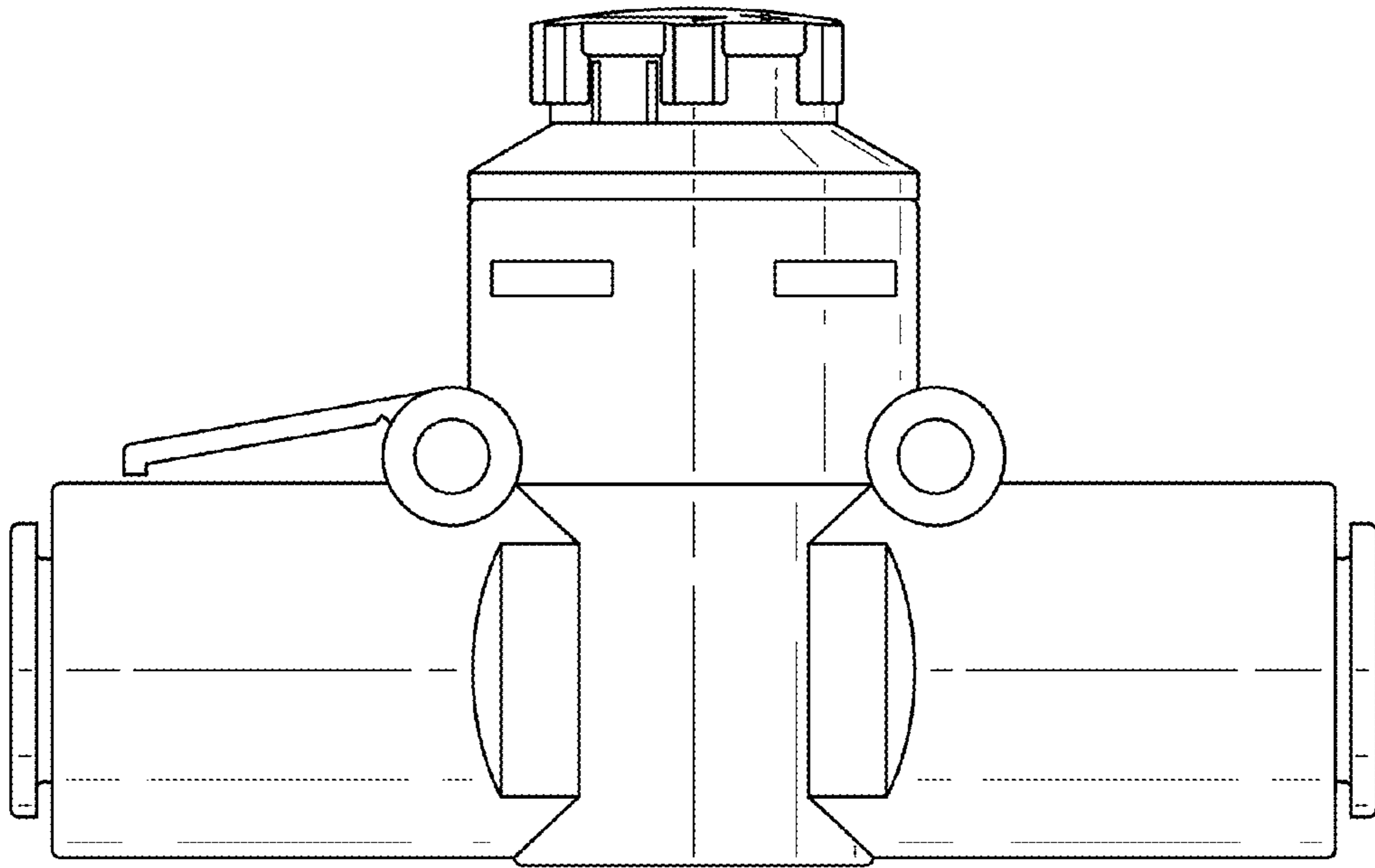

FIG. 45

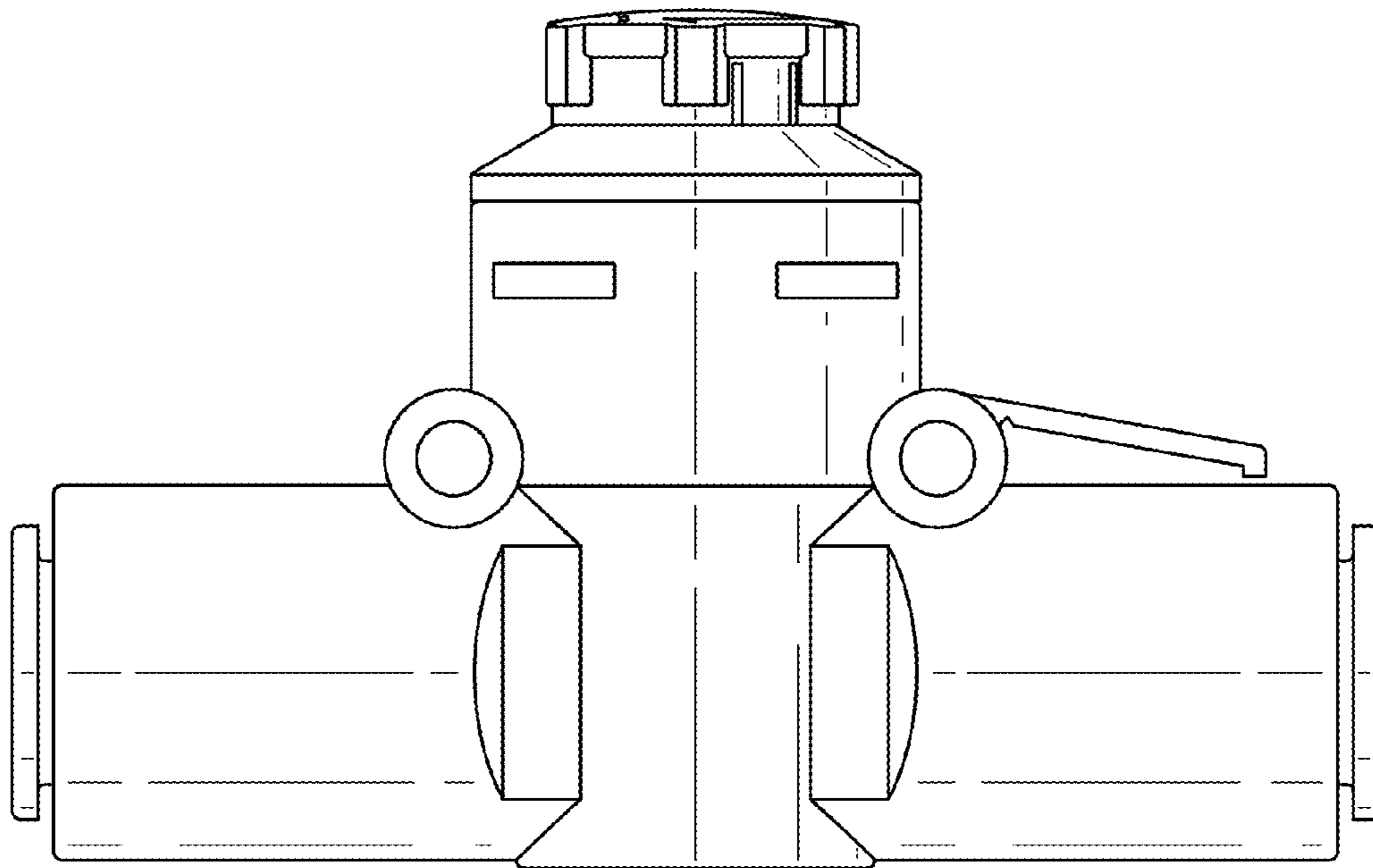

FIG. 46

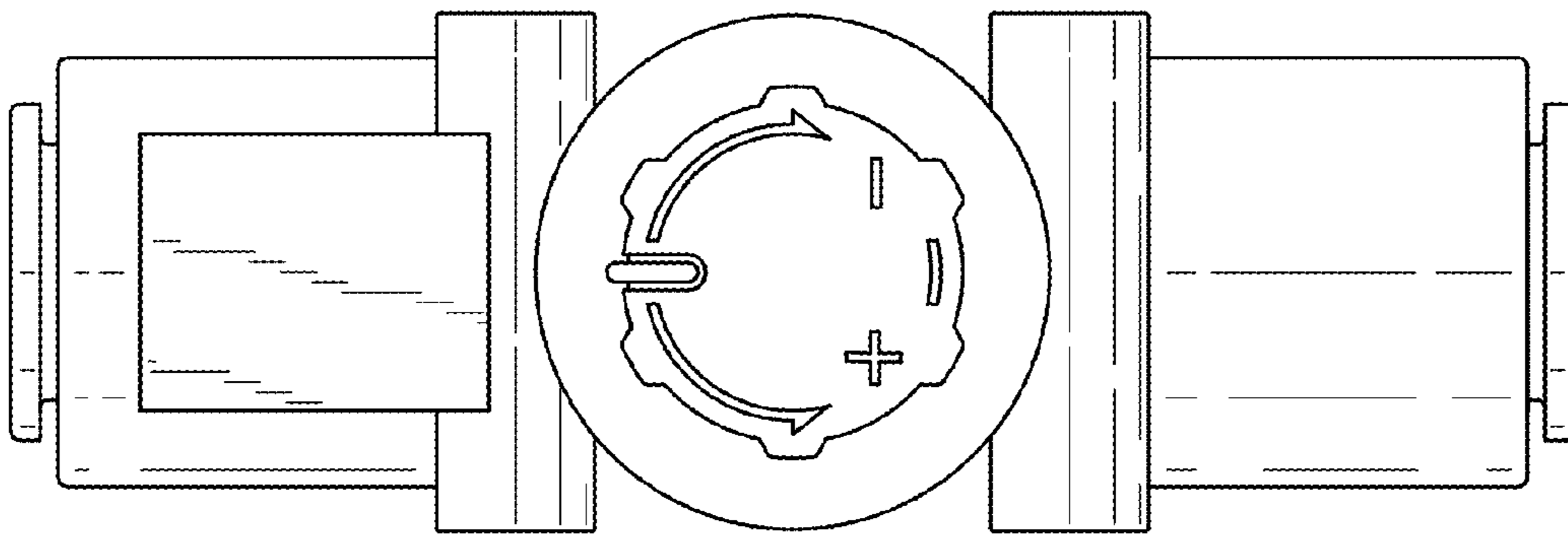

FIG. 47

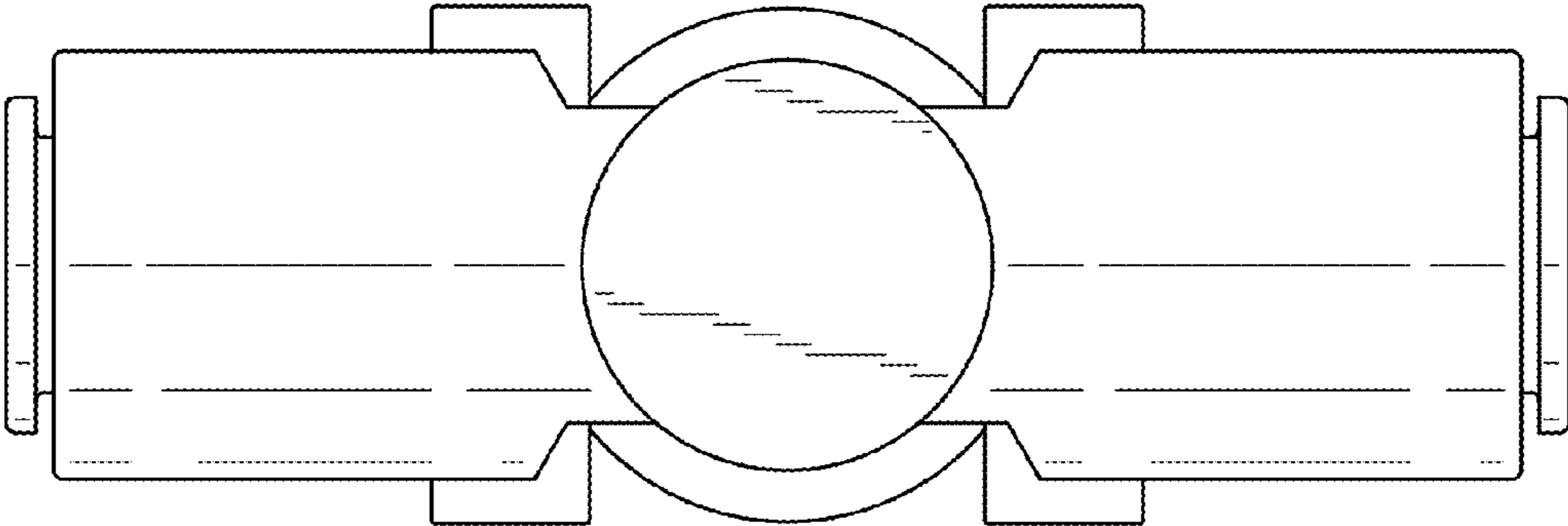

FIG. 48

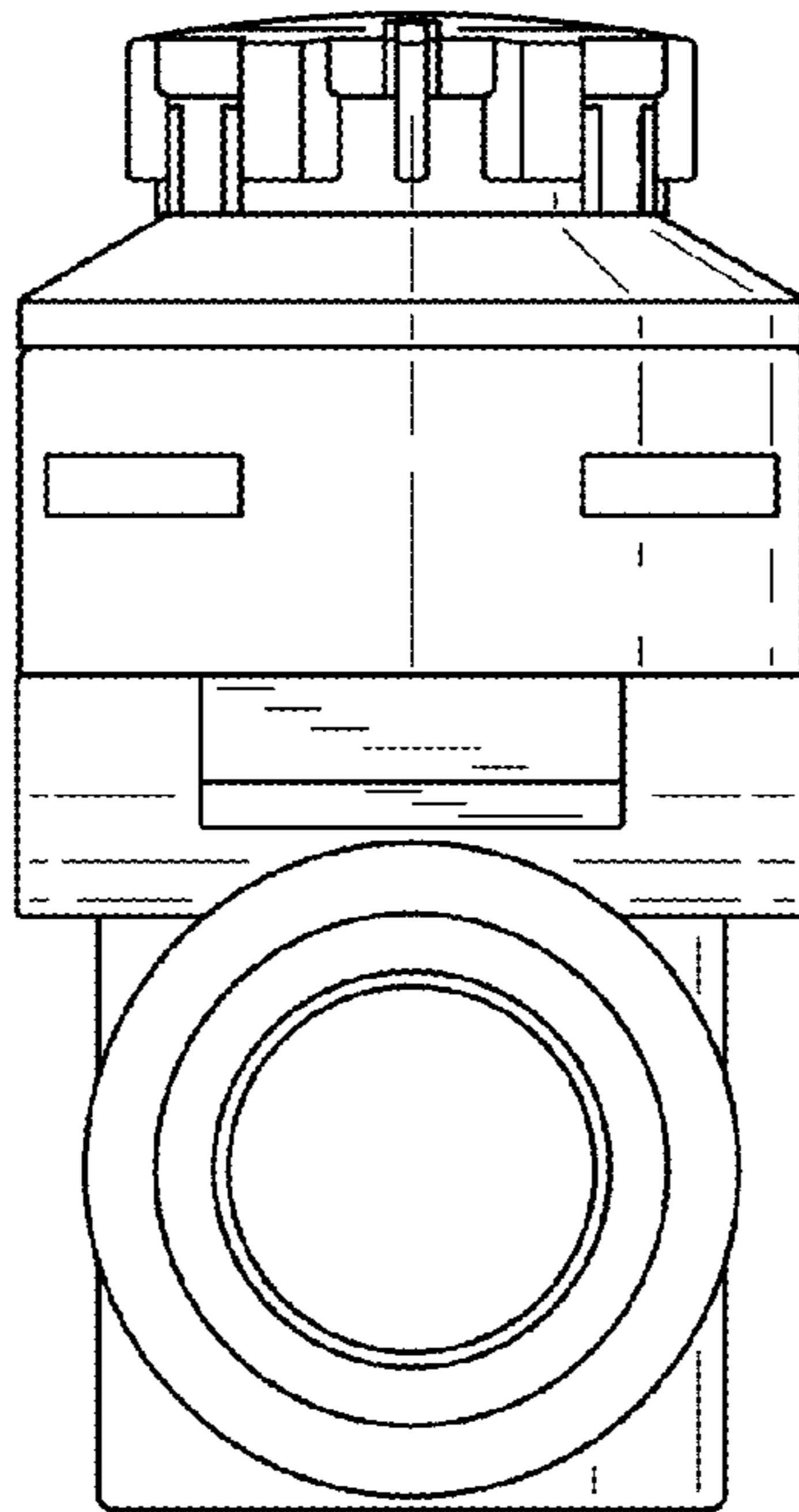

FIG. 49

