



US00D752998S

(12) **United States Design Patent**
Robinson et al.

(10) **Patent No.:** **US D752,998 S**

(45) **Date of Patent:** **** Apr. 5, 2016**

(54) **NAVIGATION SATELLITE SYSTEM
RECEIVER**

(71) Applicant: **Trimble Navigation Limited,**
Sunnyvale, CA (US)

(72) Inventors: **Scott Keith Robinson,** Newark, CA
(US); **Jack Spencer Warner,**
Bellingham, WA (US)

(73) Assignee: **Trimble Navigation Limited,**
Sunnyvale, CA (US)

(**) Term: **14 Years**

(21) Appl. No.: **29/515,067**

(22) Filed: **Jan. 20, 2015**

(51) **LOC (10) Cl.** **10-04**

(52) **U.S. Cl.**
USPC **D10/65**

(58) **Field of Classification Search**
USPC D10/65, 70
CPC G08G 1/096883; G08G 1/096872;
G08G 1/096775; G01C 21/16; G01C 21/3688;
G01C 21/30; G01V 8/20; G01J 5/02; G01J
5/023; G01J 5/24; G01J 5/10; G01J 5/20;
G01J 5/0235; G01J 5/08; G01J 5/0853;
G01J 5/33; G01J 5/34

See application file for complete search history.

(56) **References Cited**

U.S. PATENT DOCUMENTS

D519,392 S * 4/2006 Ishii D10/65
D697,438 S * 1/2014 Rector, III D10/65

* cited by examiner

Primary Examiner — Antoine D Davis

(57) **CLAIM**

We claim the ornamental design for a navigation satellite system receiver, as shown and described.

DESCRIPTION

FIG. 1 is a top front right perspective view of a navigation satellite system receiver showing our new design, features shown in broken line are for illustrative purposes only and form no part of the claimed design;

FIG. 2 is a front elevational view of our navigation satellite system receiver, features shown in broken line are for illustrative purposes only and form no part of the claimed design; FIG. 3 is a right side elevational view of our navigation satellite system receiver, the left side elevational view is a mirror image thereof;

FIG. 4 is a rear elevational view of our navigation satellite system receiver, features shown in broken line are for illustrative purposes only and form no part of the claimed design; FIG. 5 is a top plan view of our navigation satellite system receiver; and,

FIG. 6 is a bottom plan view of our navigation satellite system receiver, features shown in broken line are for illustrative purposes only and form no part of the claimed design.

1 Claim, 3 Drawing Sheets

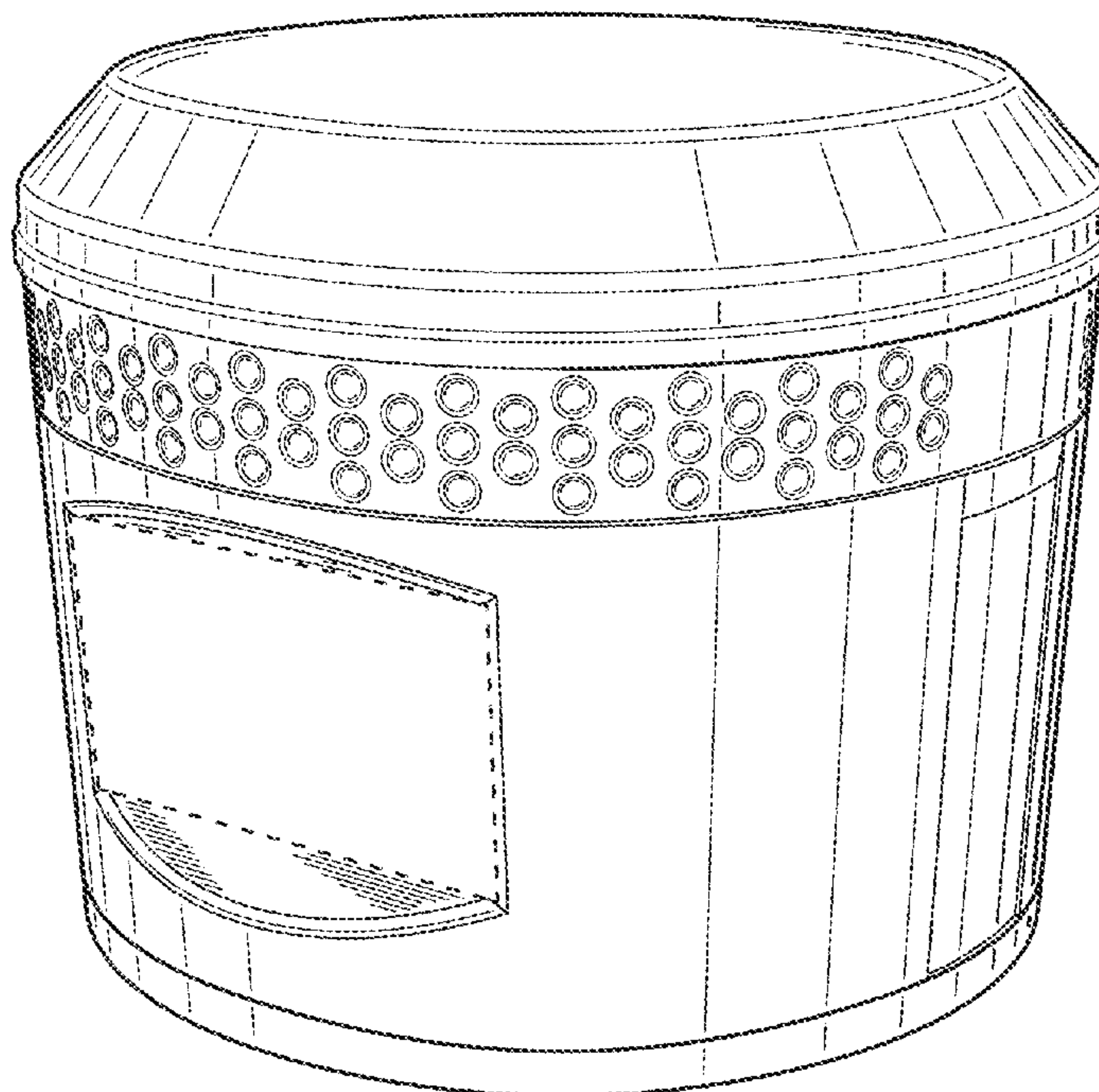

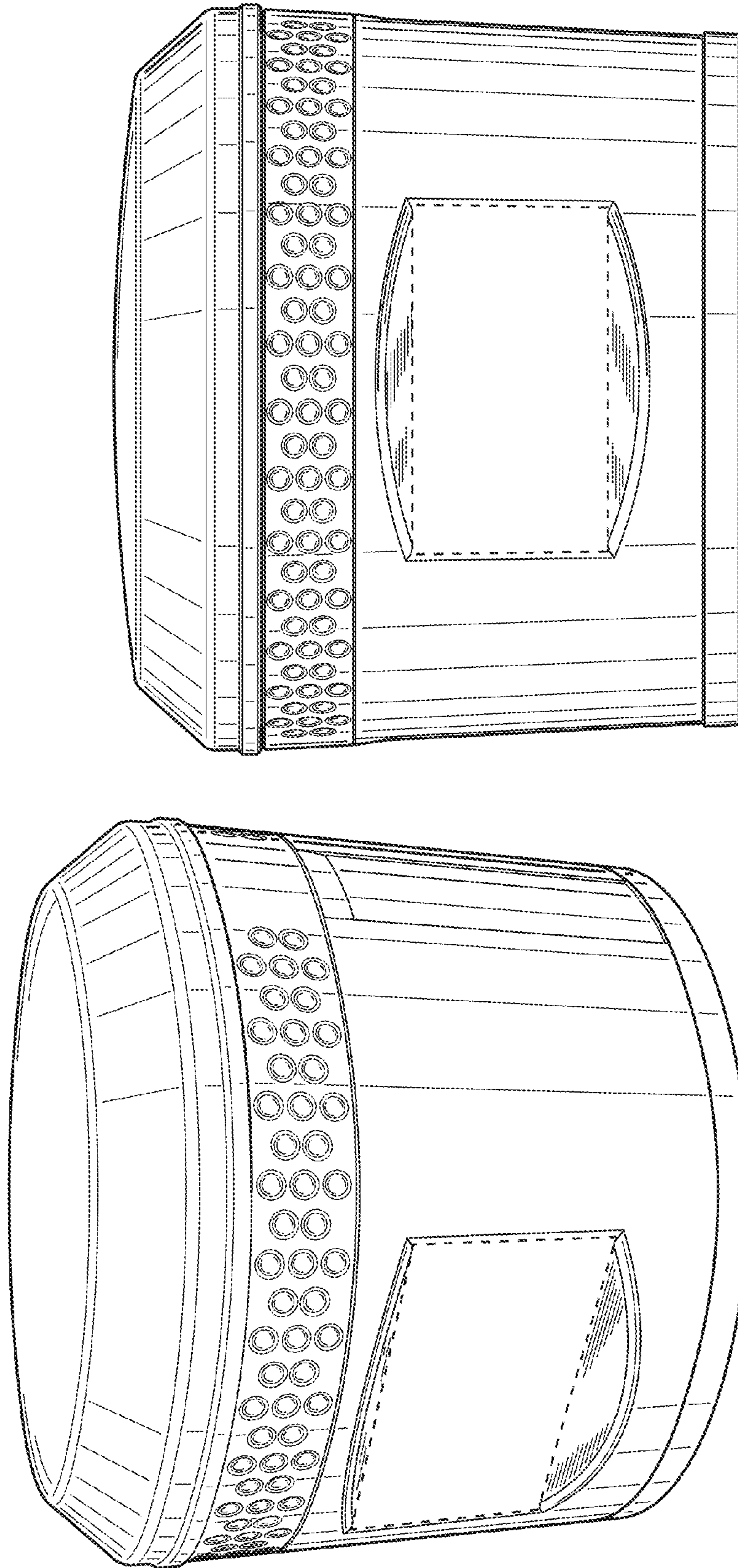

FIG. 2

FIG. 1

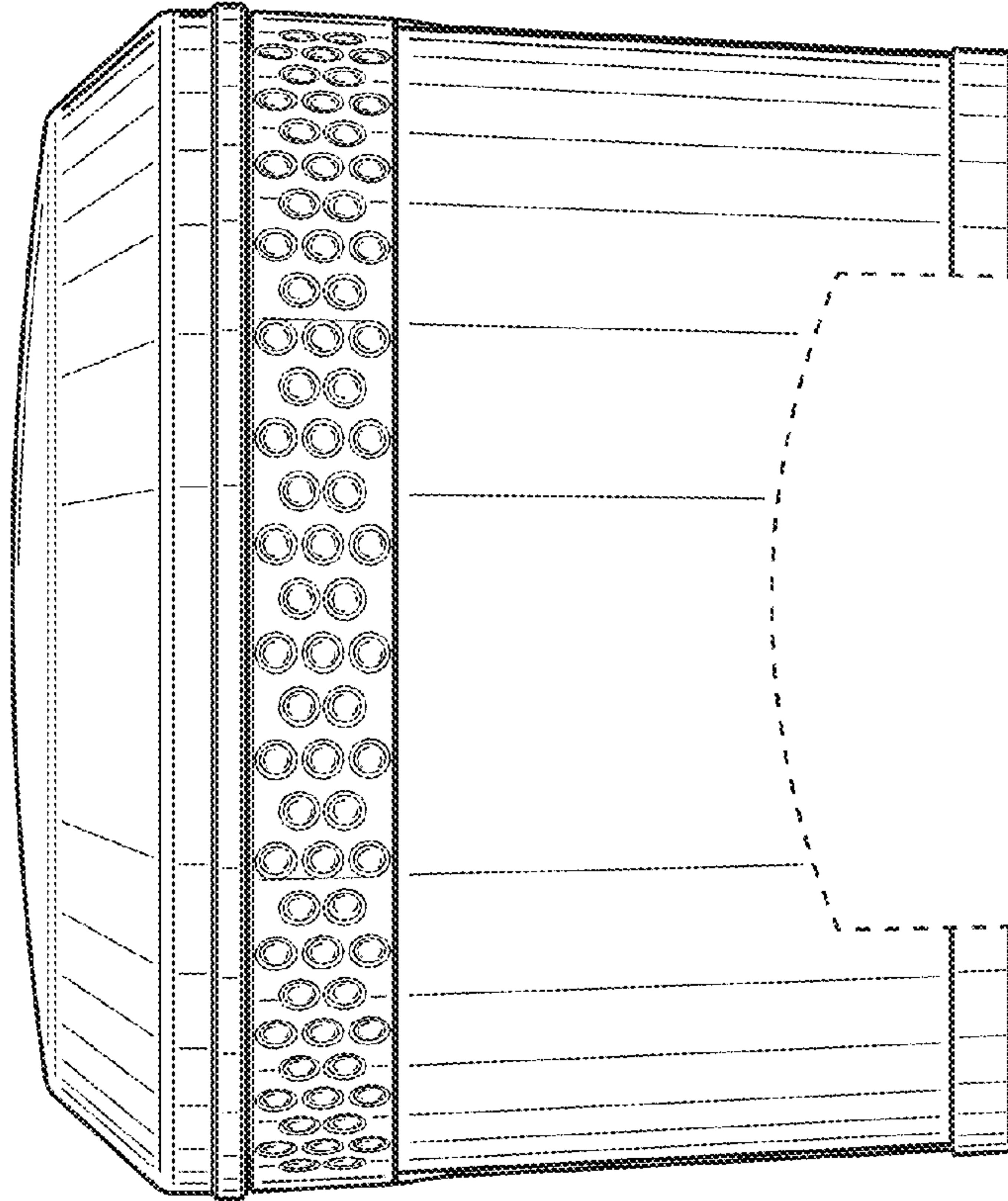

FIG. 4

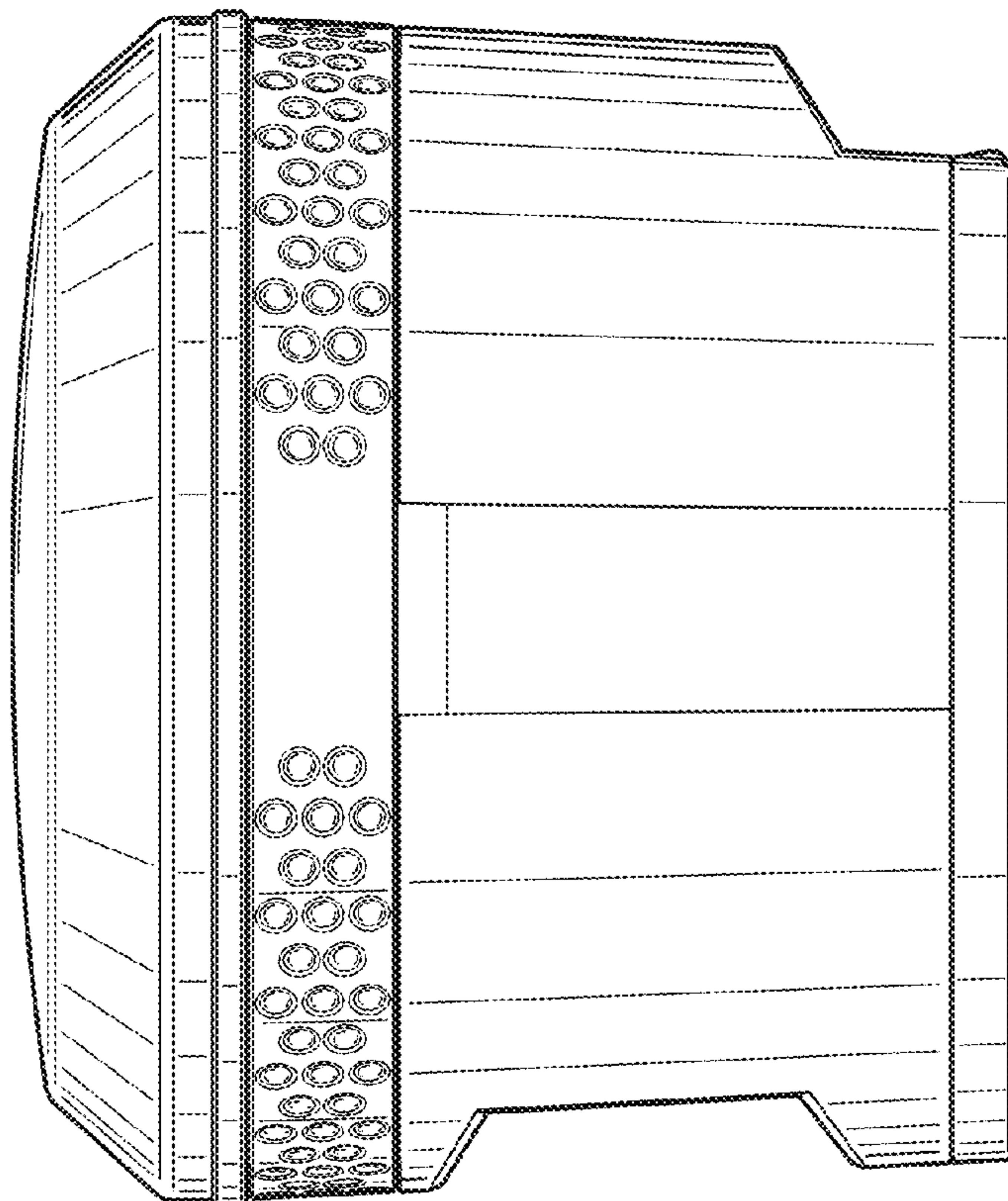

FIG. 3

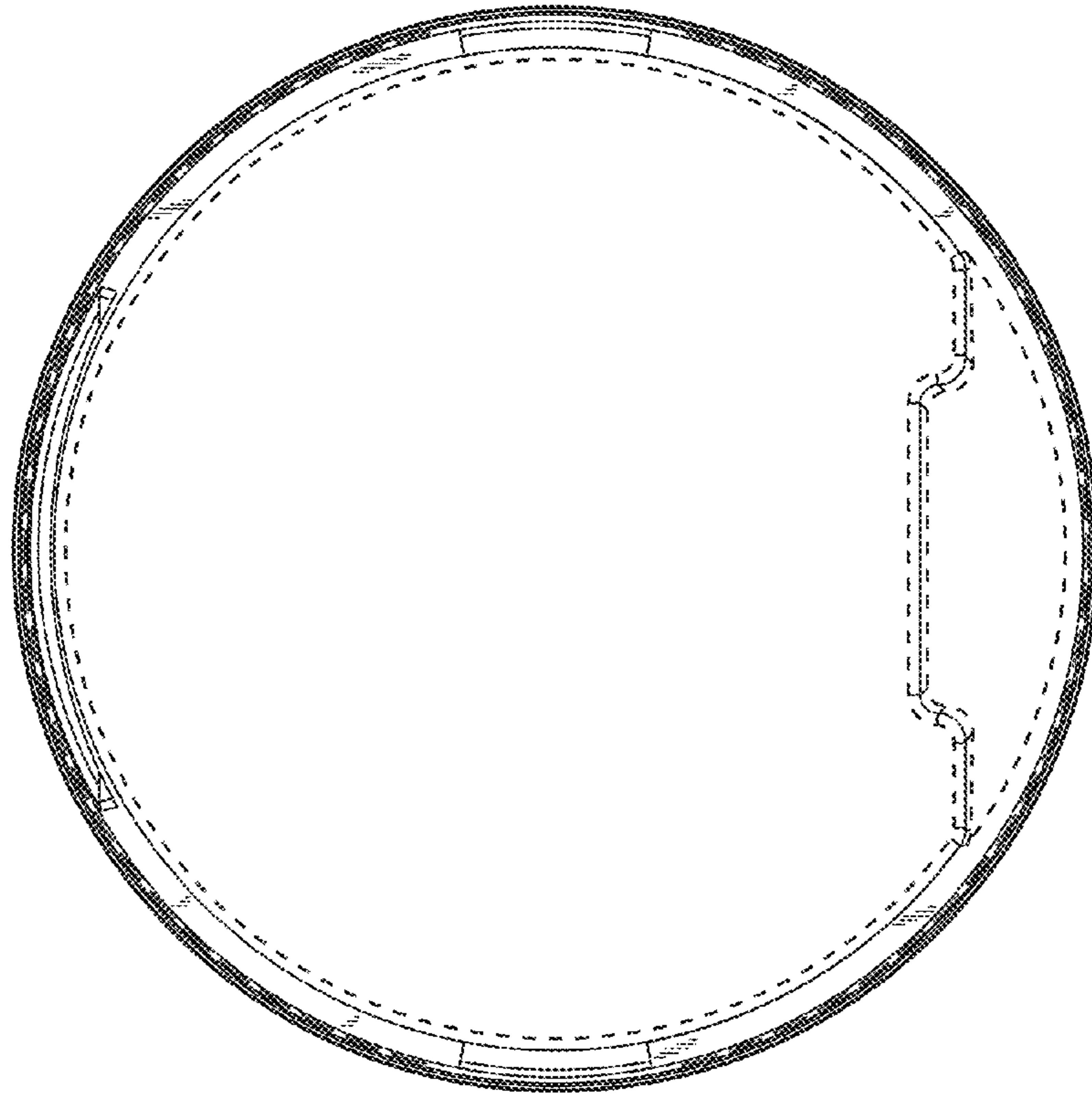

FIG. 6

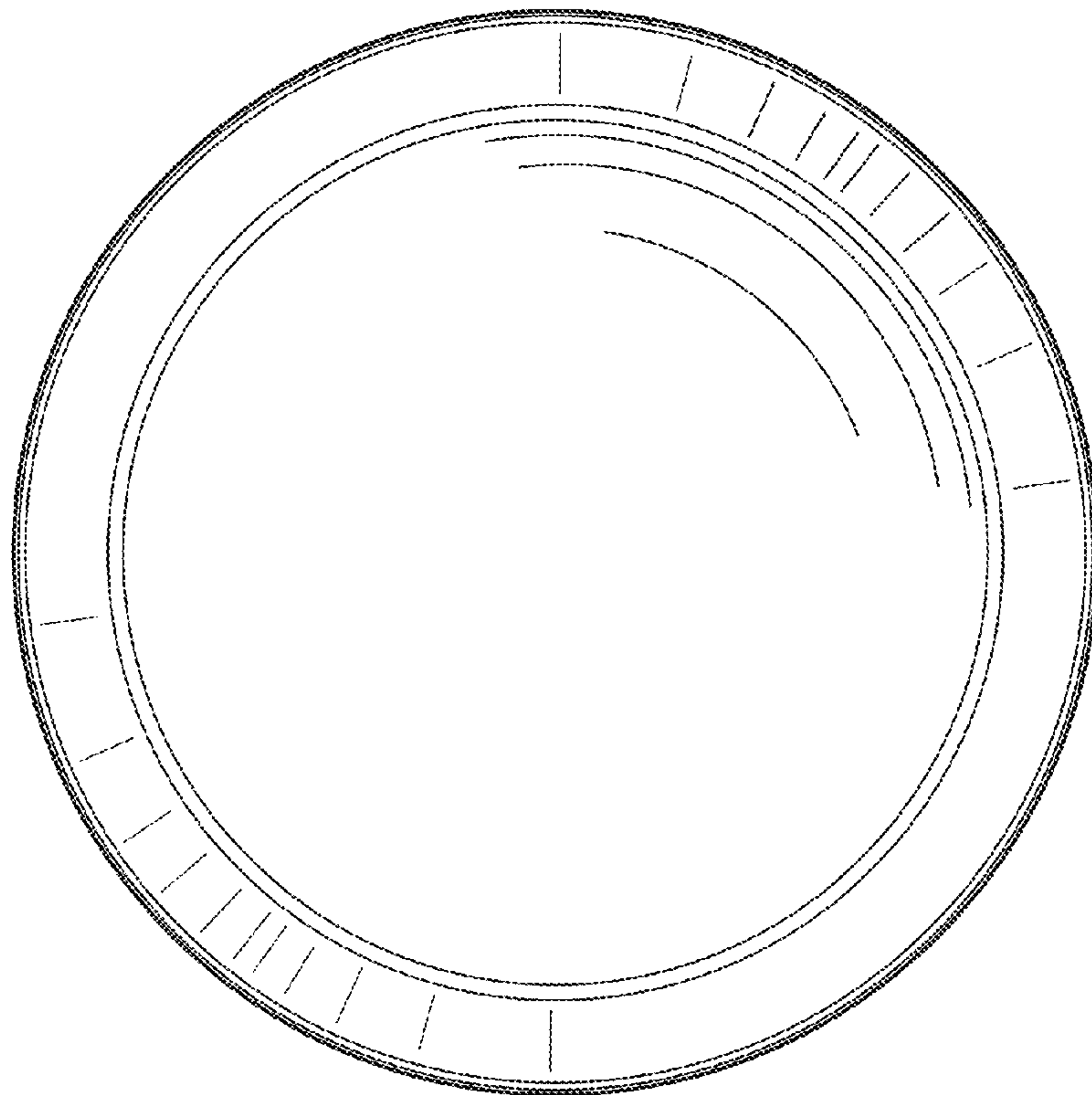

FIG. 5