



US00D752962S

(12) **United States Design Patent**
Cottier

(10) **Patent No.:** **US D752,962 S**

(45) **Date of Patent:** **** Apr. 5, 2016**

(54) **COMBINED INSERT AND SCREW ELEMENT**

(71) Applicant: **James Hardie Technology Limited,**
Dublin 2 (IE)

(72) Inventor: **John Cottier,** Rosehill (AU)

(73) Assignee: **James Hardie Technology Limited,**
Dublin (IE)

(**) Term: **14 Years**

(21) Appl. No.: **29/464,402**

(22) Filed: **Aug. 15, 2013**

(30) **Foreign Application Priority Data**

Feb. 15, 2013 (AU) 347967

(51) **LOC (10) Cl.** **08-08**

(52) **U.S. Cl.**
USPC **D8/385**

(58) **Field of Classification Search**

USPC D8/385, 387, 391, 388, 393
CPC F16B 15/00; F16B 17/00; F16B 19/00;
F16B 21/00; F16B 15/02; F16B 15/08;
F16B 19/02; F16B 19/04

See application file for complete search history.

(56) **References Cited**

U.S. PATENT DOCUMENTS

D29,283 S * 8/1898 Sweeny D8/391
D101,962 S * 11/1936 Le Breux D8/391
D101,971 S * 11/1936 Shchuster D8/391
D101,972 S * 11/1936 Shchuster D8/391
4,943,197 A * 7/1990 Baritz 411/375
4,990,041 A * 2/1991 Winston 411/23
D322,556 S * 12/1991 Jeter D8/388
D324,649 S * 3/1992 Lederhaus, Jr. D8/391
5,370,487 A * 12/1994 Kracke 411/485
D366,113 S * 1/1996 Morgan D24/145
D375,452 S * 11/1996 Housser D8/393
D415,676 S * 10/1999 Negishi et al. D8/387
D462,257 S * 9/2002 Alexander D8/391

6,457,213 B2 * 10/2002 Watanabe 24/94
D483,253 S * 12/2003 Sayegh et al. D8/388
D517,404 S * 3/2006 Schluter D8/387
D518,606 S * 4/2006 Cross D30/199
D590,704 S * 4/2009 Brunsteter D8/387
D712,242 S * 9/2014 Deneve D8/391

* cited by examiner

Primary Examiner — Sheryl Lane

(74) *Attorney, Agent, or Firm* — Knobbe, Martens, Olson & Bear, LLP

(57) **CLAIM**

The ornamental design for the combined insert and screw element, as shown and described.

DESCRIPTION

FIG. 1 is a perspective view of an insert for screw element in accordance with the present design.

FIG. 2 is an exploded perspective view of the insert for screw element in FIG. 1.

FIG. 3 is a front view of the insert for screw element in FIG. 1.

FIG. 4 is an exploded front view of the insert for screw element in FIG. 1.

FIG. 5 is a left side view of the insert for screw element in FIG. 1. The right side view is a mirror image of the left side view.

FIG. 6 is an exploded left side view of the insert for screw element in FIG. 1. The exploded right side view is a mirror image of the left side view.

FIG. 7 is a side view of the insert for screw element in FIG. 1.

FIG. 8 is an exploded side view of the insert for screw element in FIG. 1.

FIG. 9 is a top view of the insert for screw element in FIG. 1.

FIG. 10 is a bottom view of the insert for screw element in FIG. 1; and,

FIG. 11 is a bottom view of the insert portion of the insert for screw element in FIG. 1.

The broken lines represent the screw element and form no part of the claimed design.

1 Claim, 7 Drawing Sheets

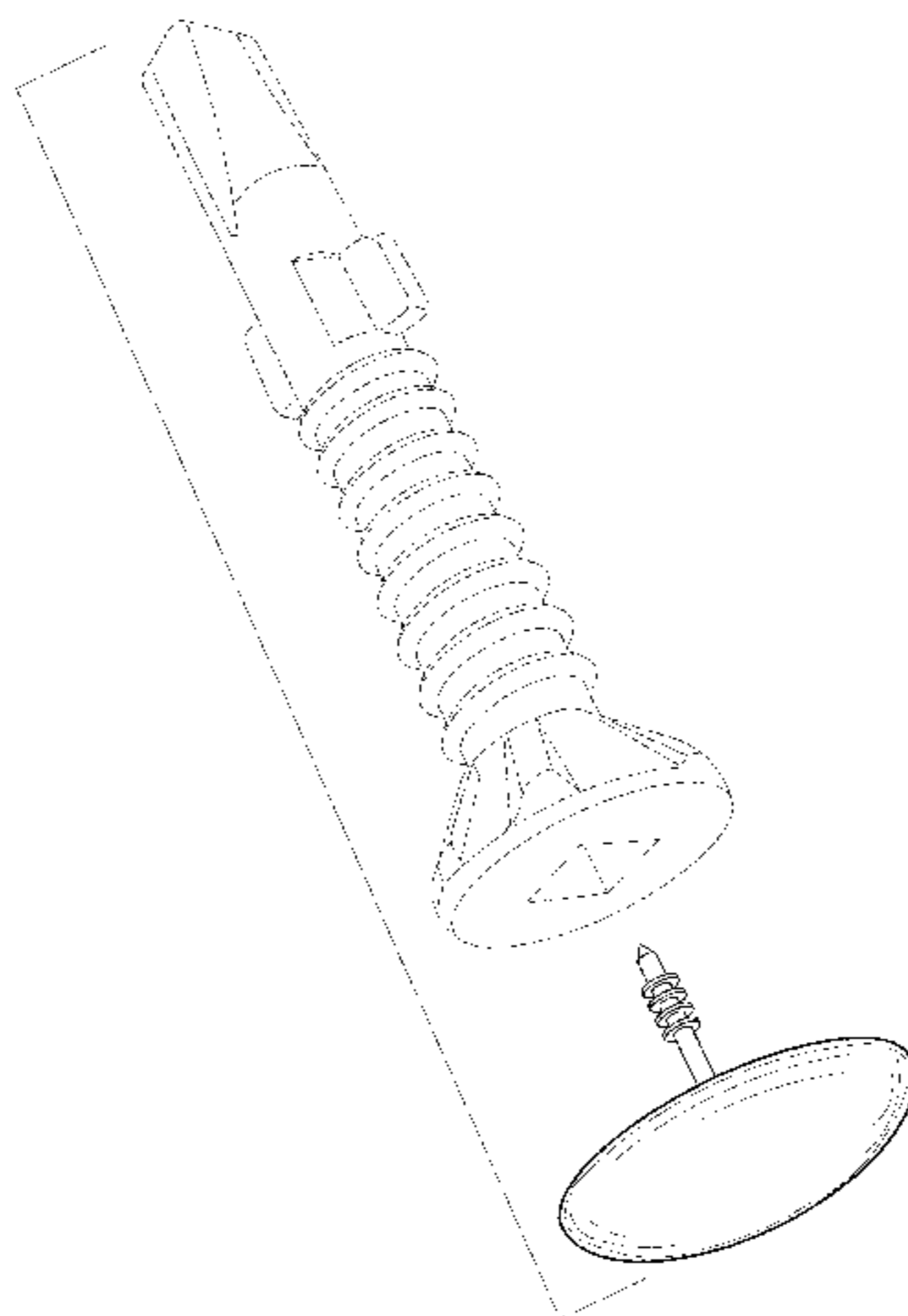

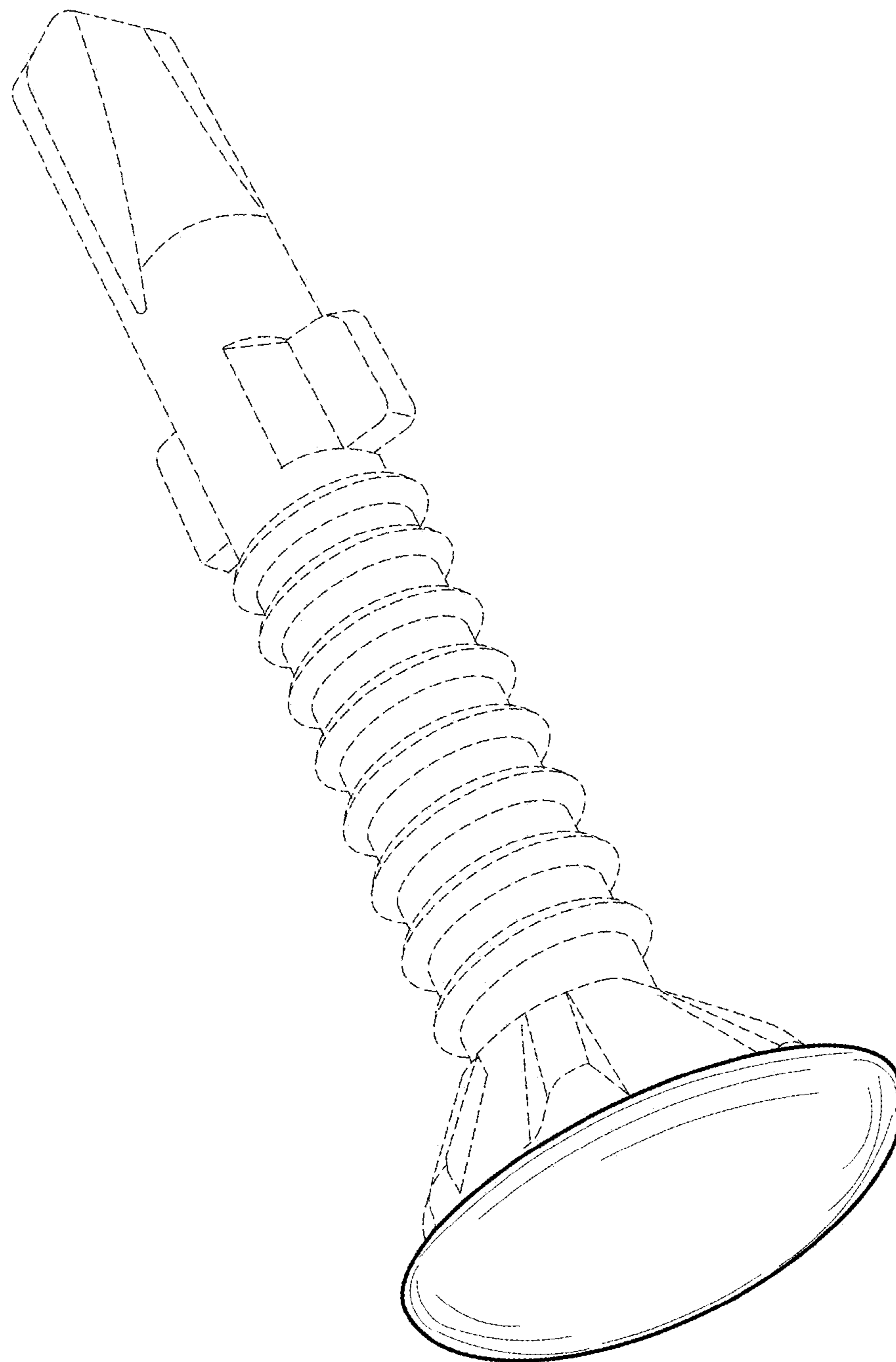

Figure 1

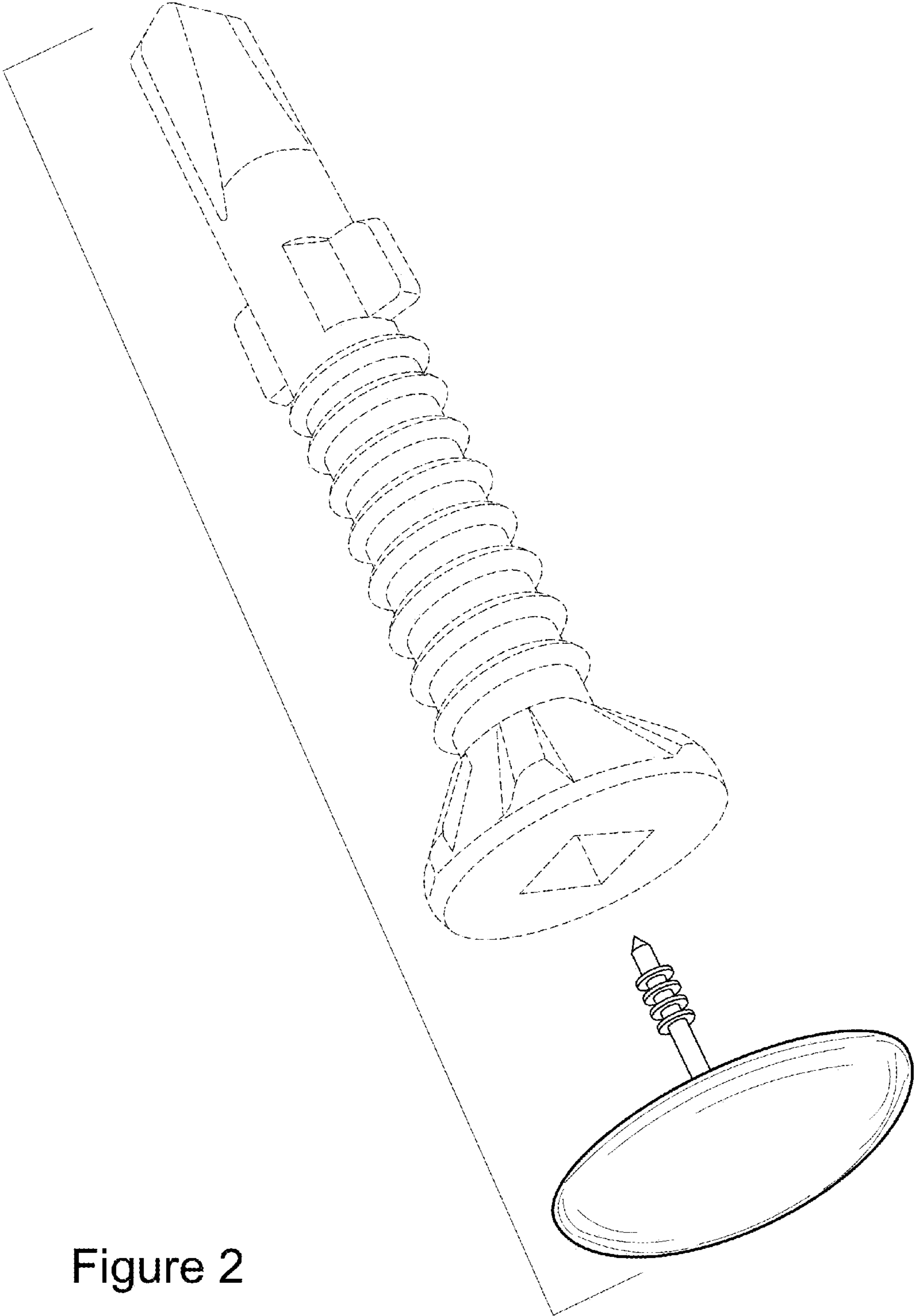

Figure 2

Figure 3

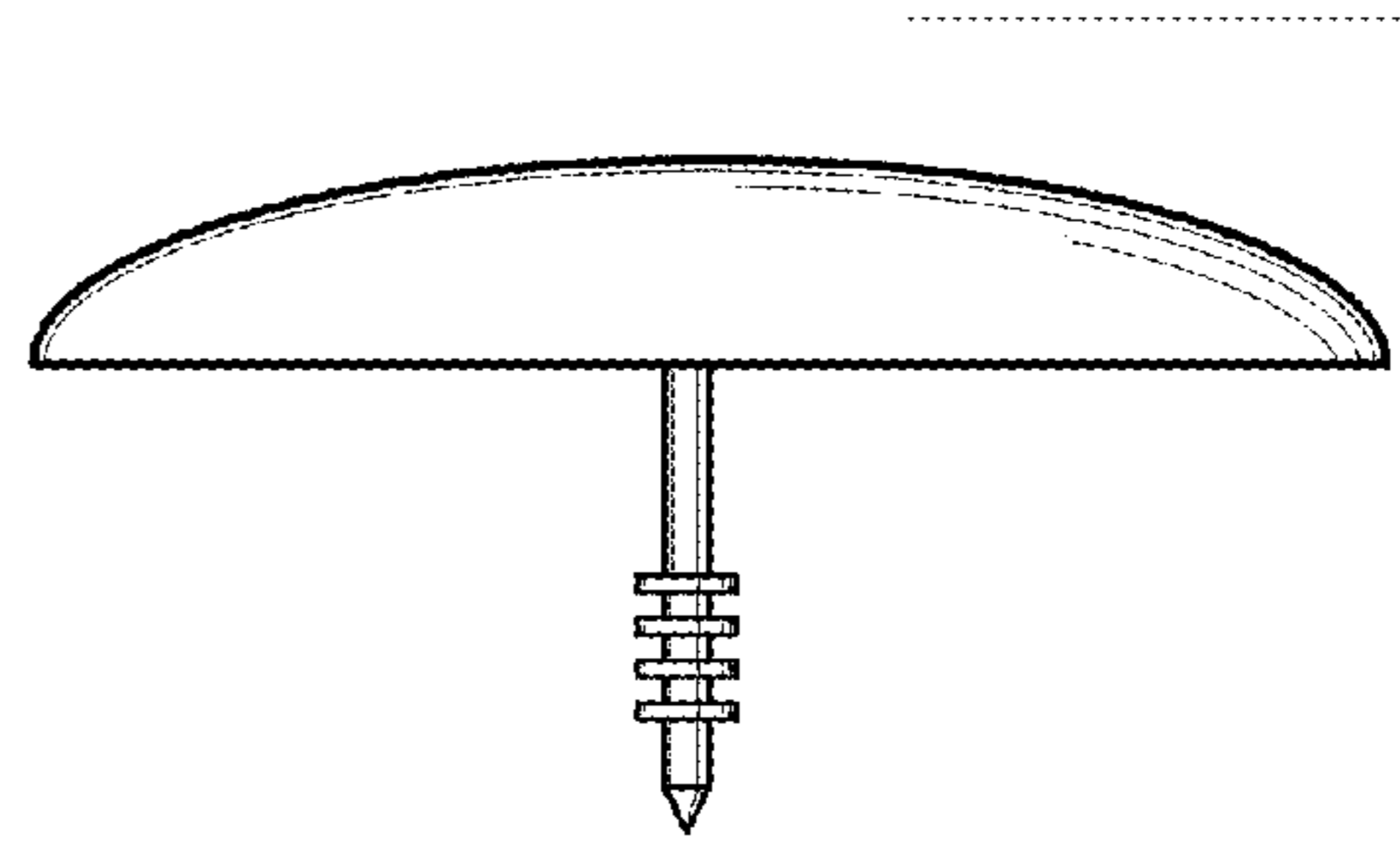
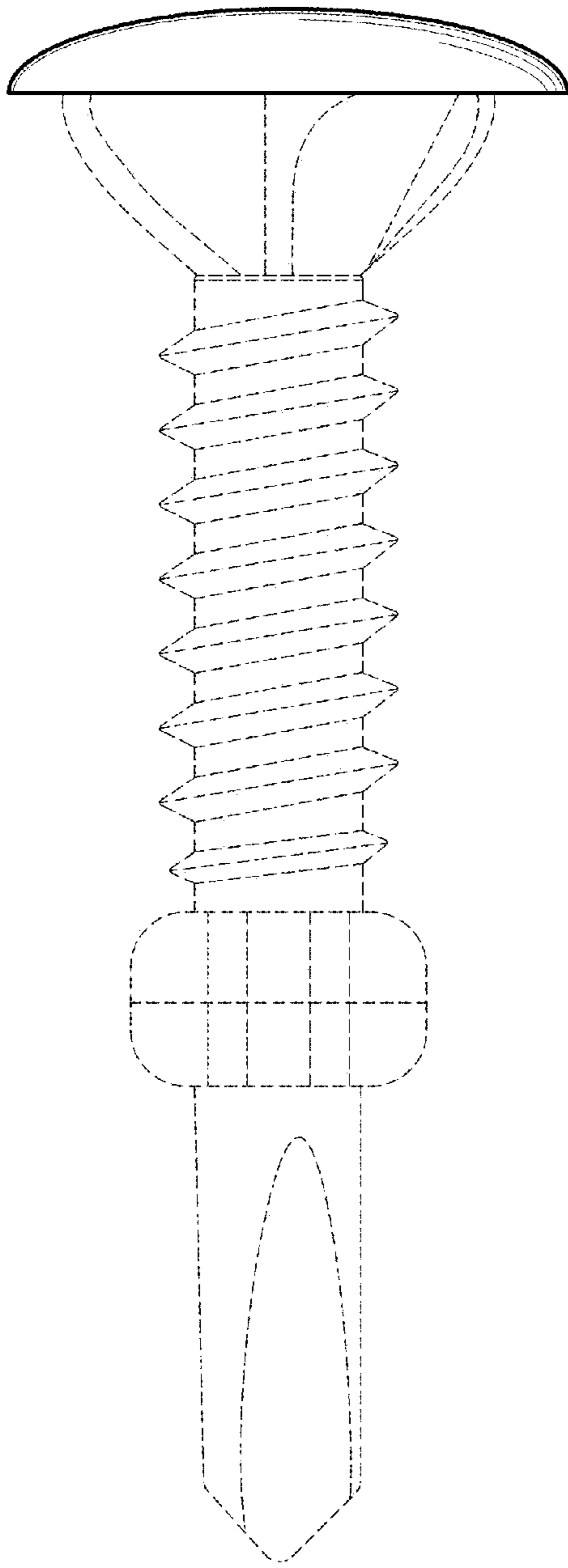

Figure 4

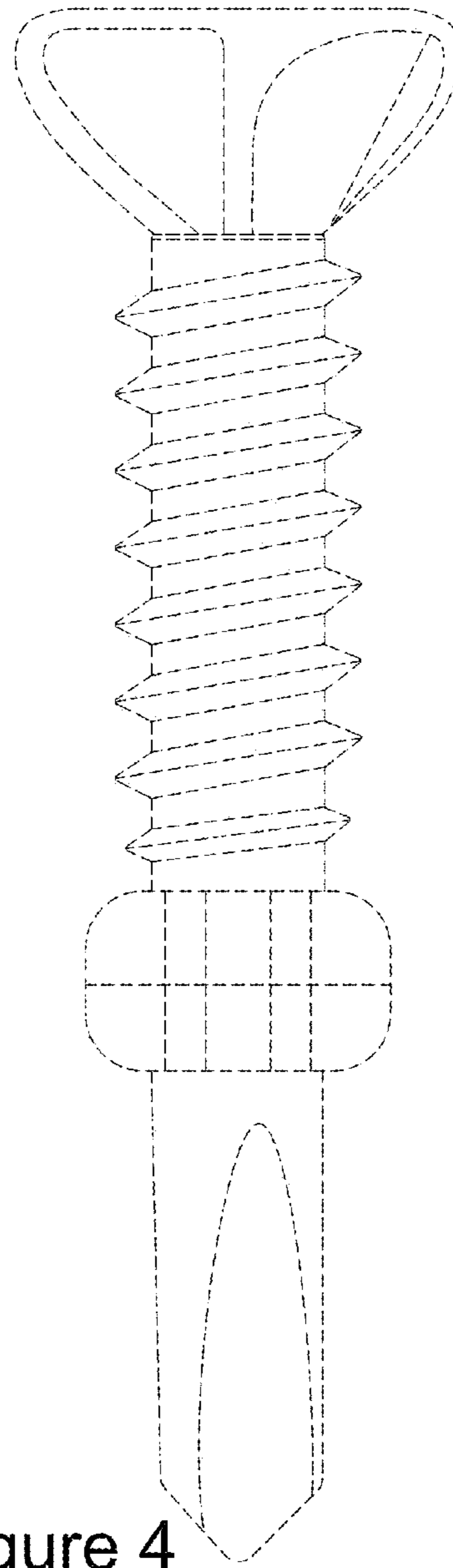

Figure 5

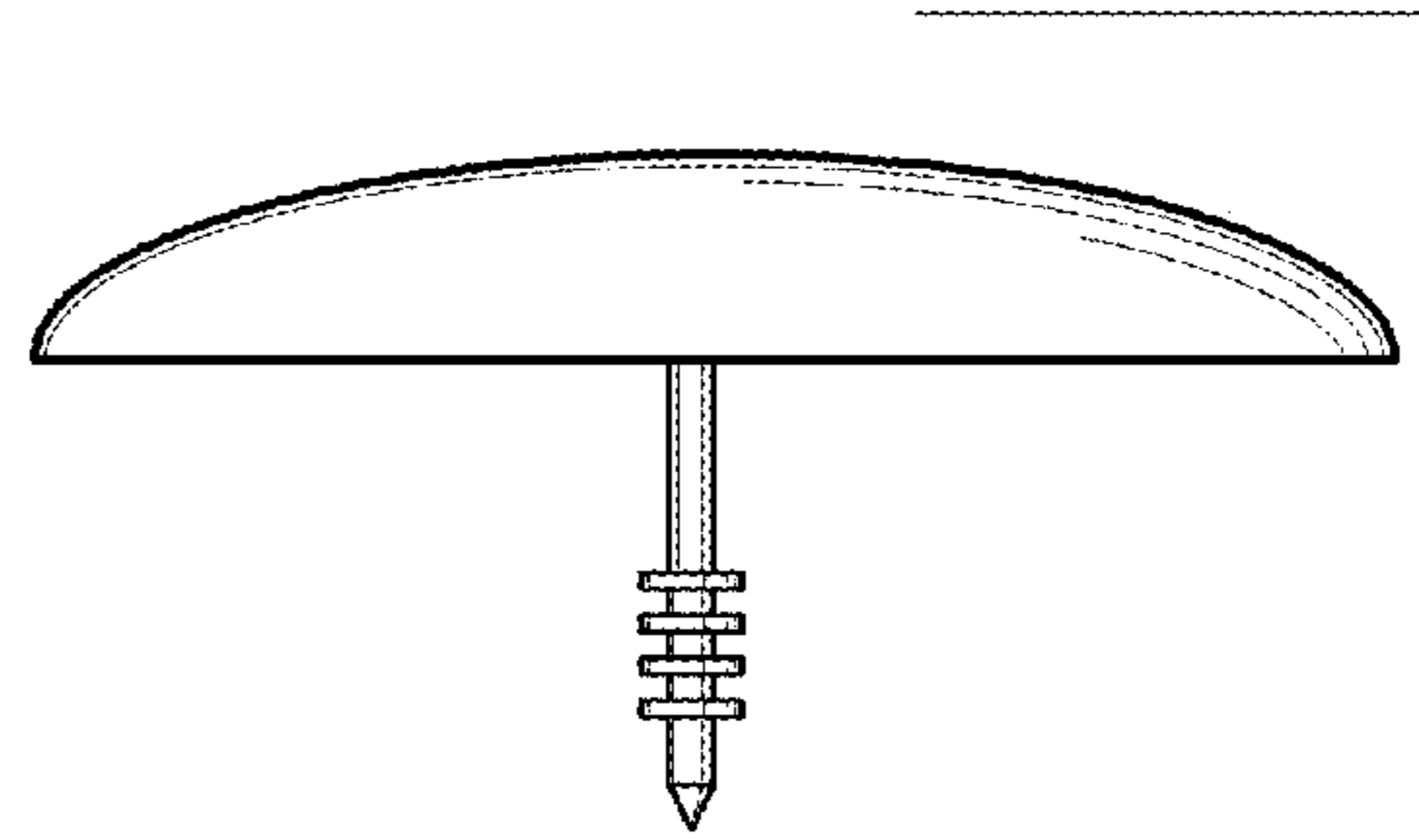
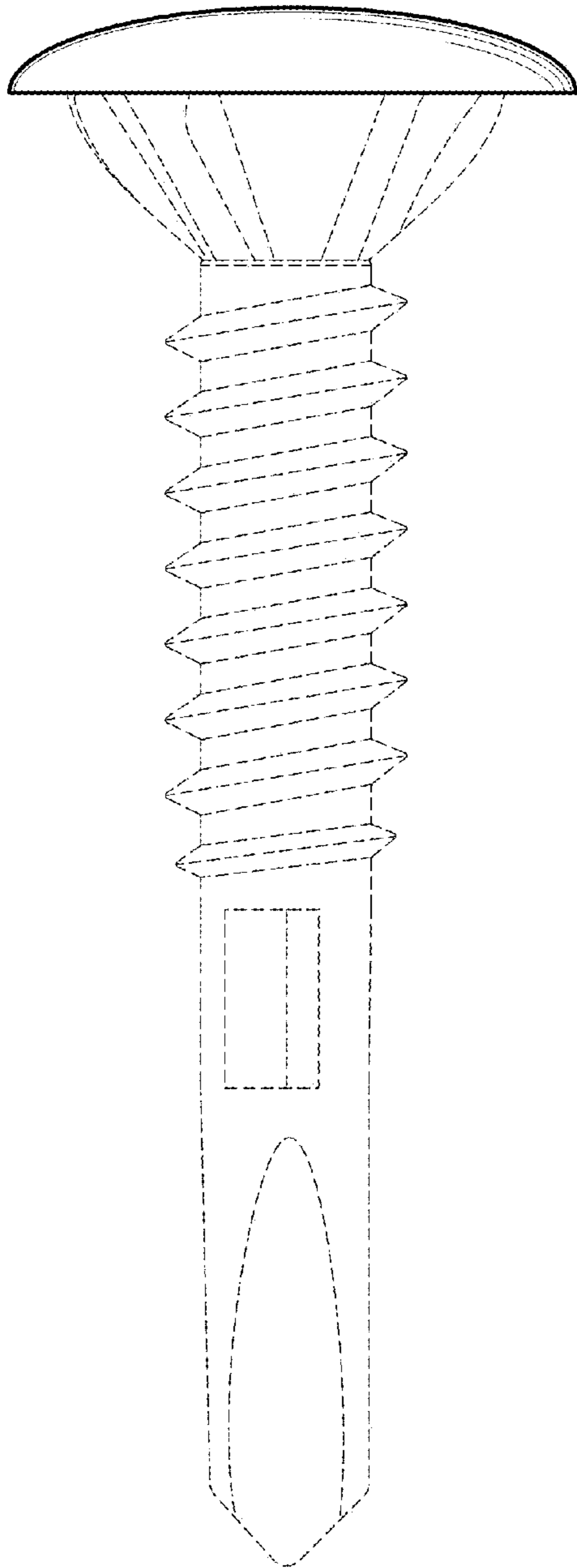

Figure 6

Figure 7

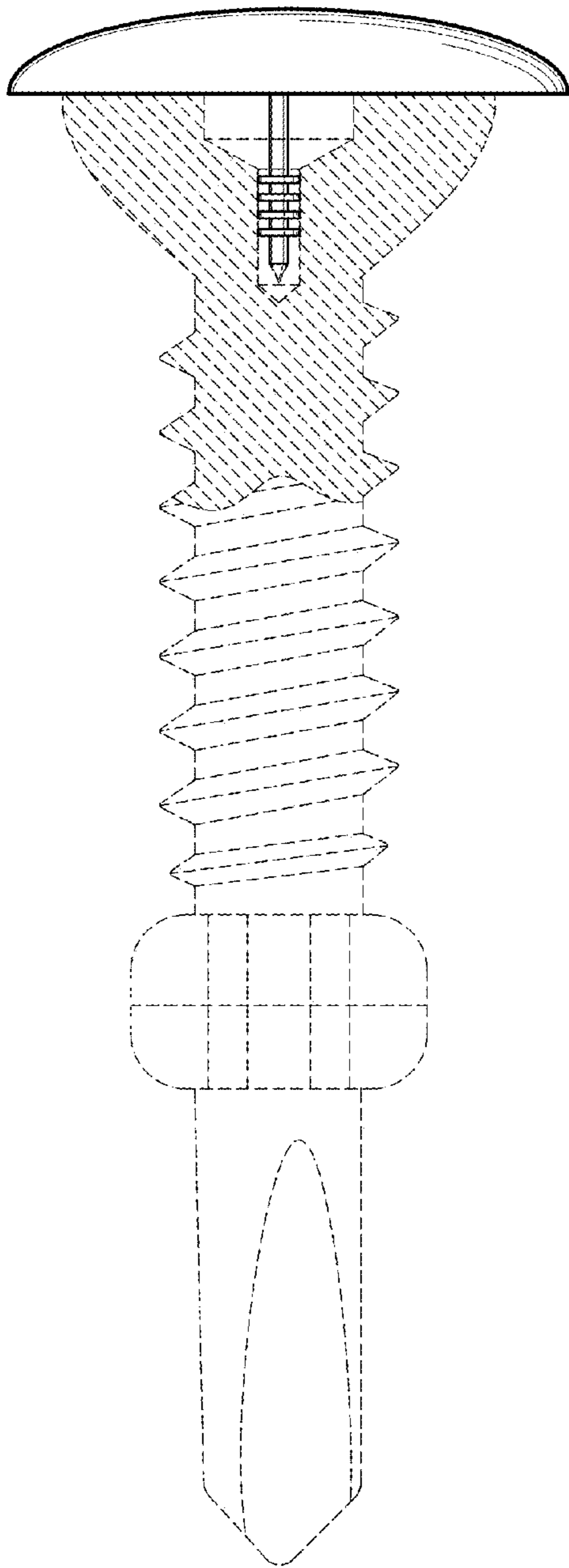
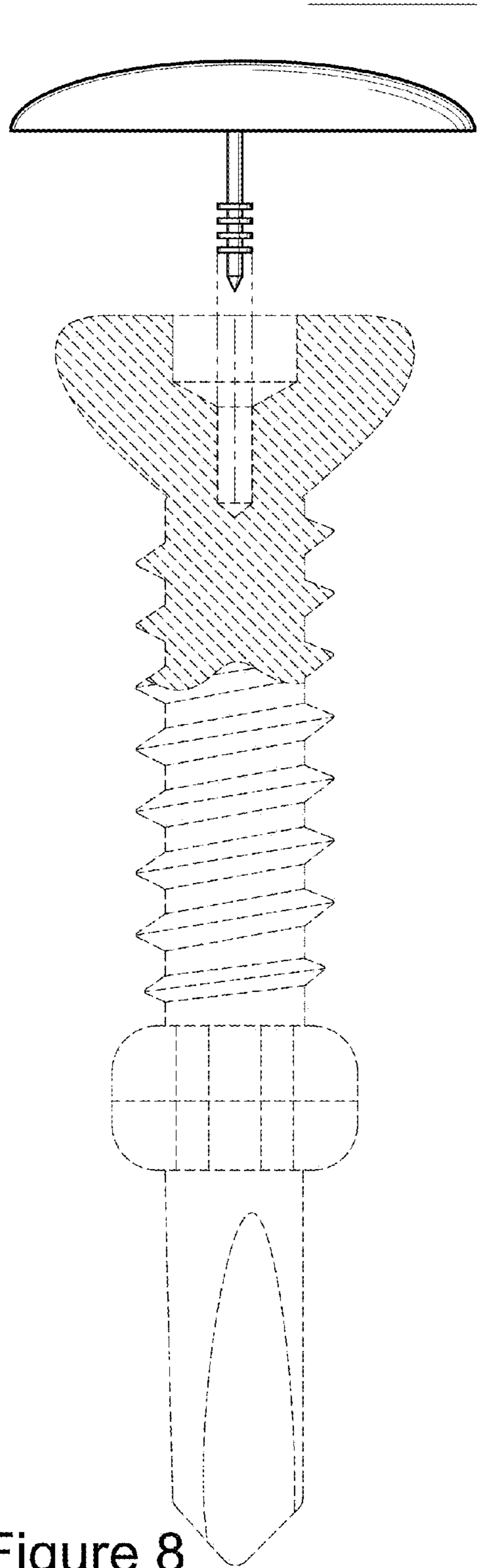

Figure 8



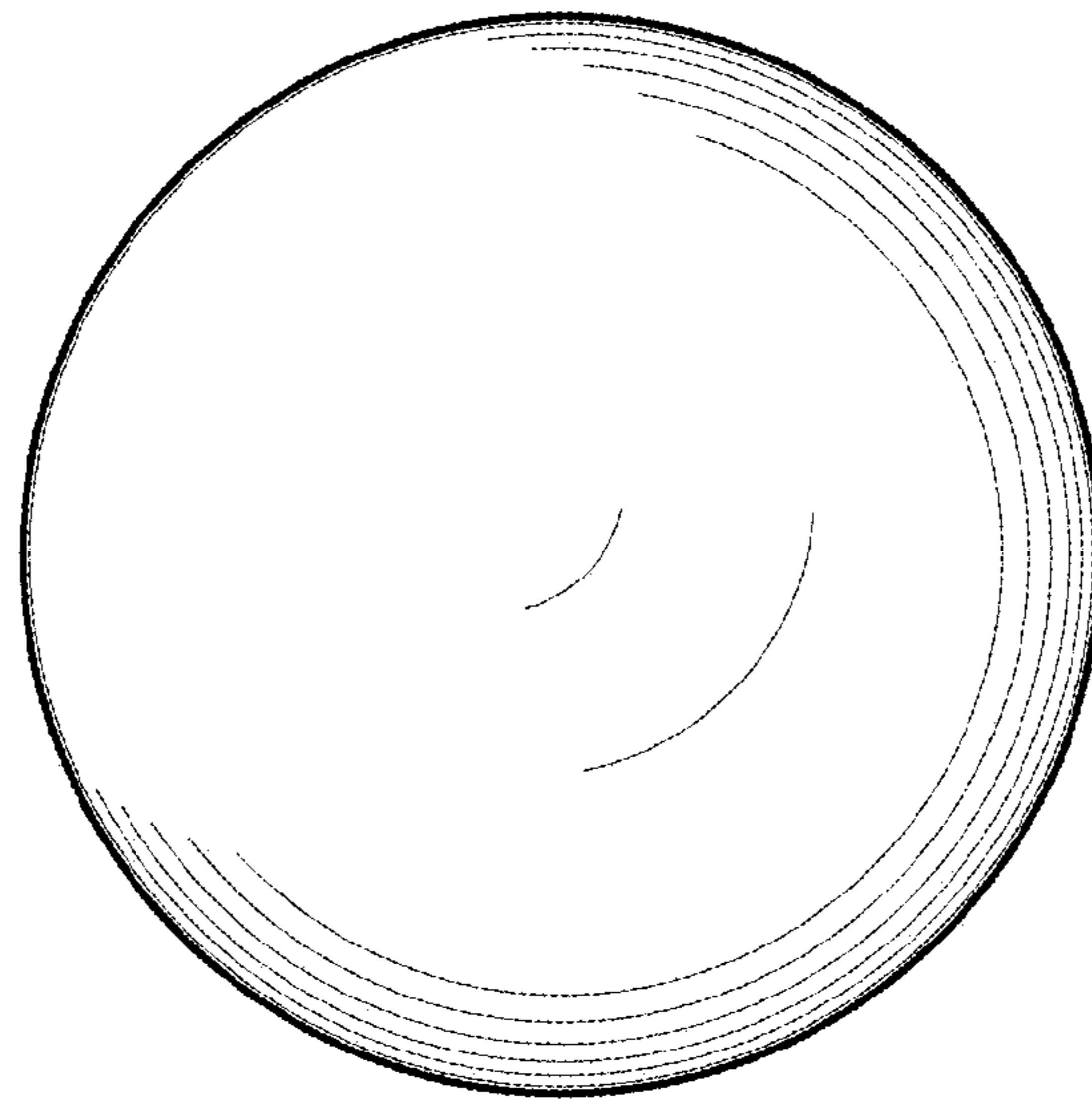

Figure 9

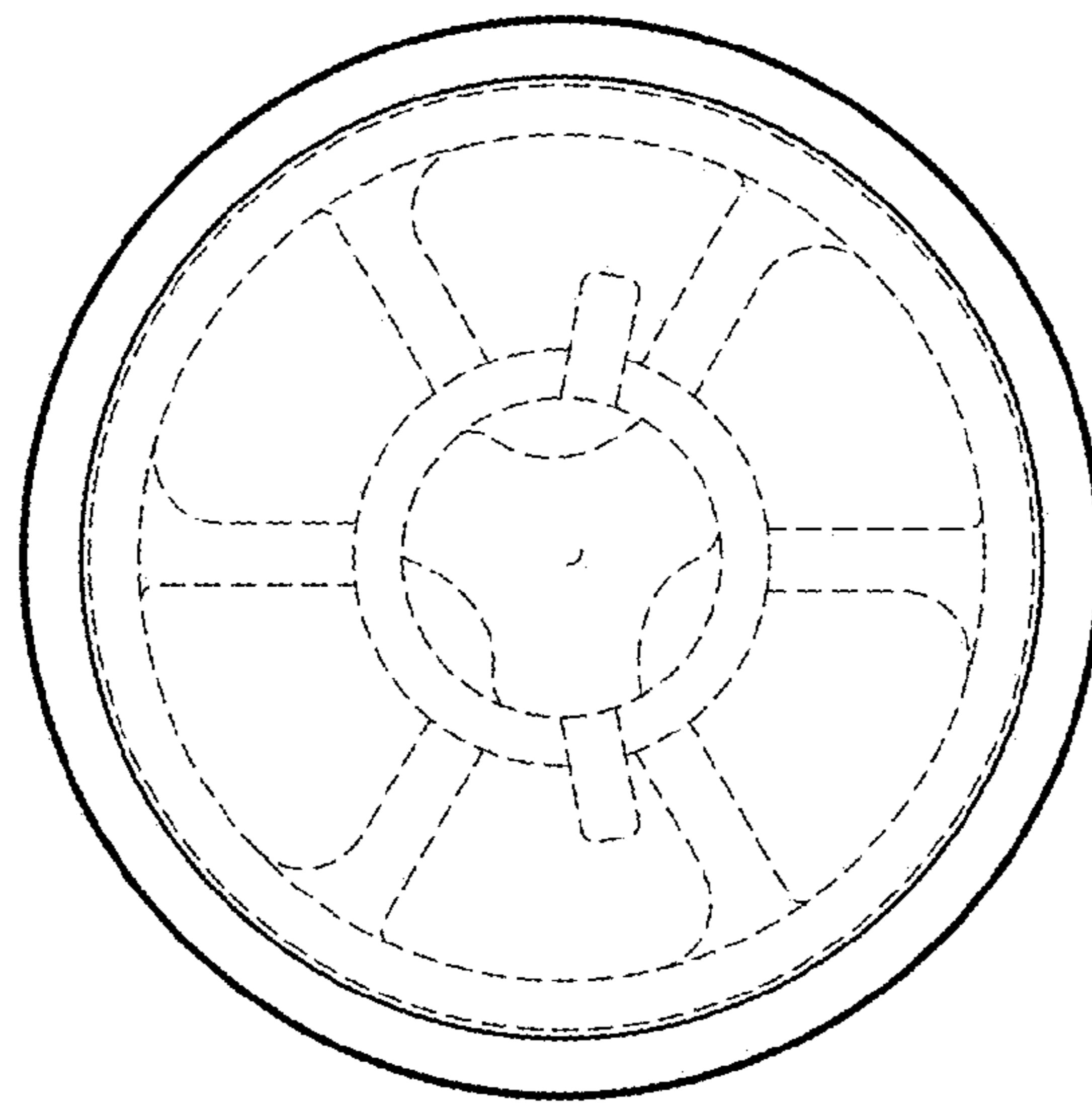

Figure 10

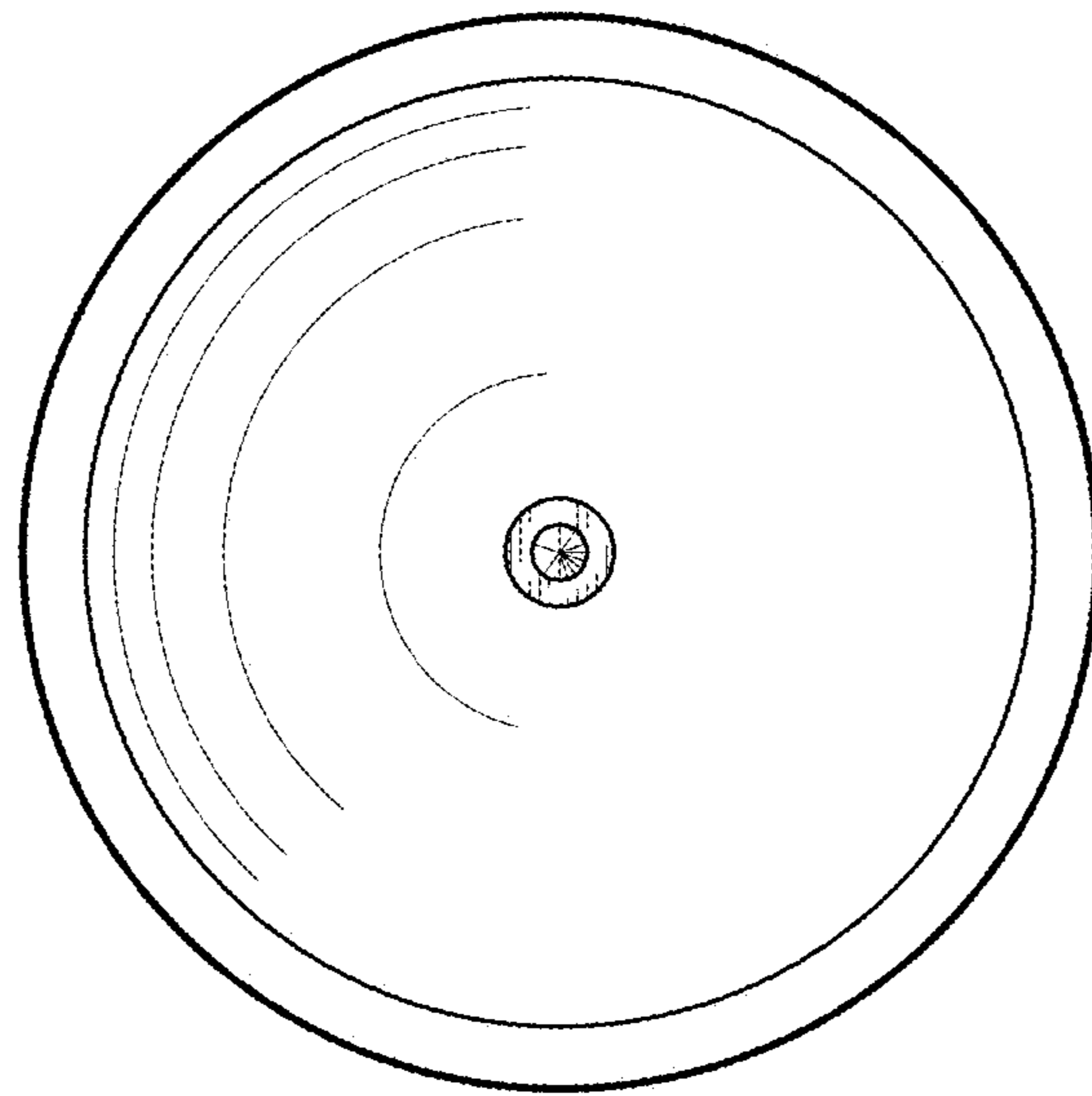

Figure 11