



US00D752759S

(12) **United States Design Patent**
Chung et al.

(10) **Patent No.:** **US D752,759 S**
(45) **Date of Patent:** **** Mar. 29, 2016**

(54) **CASSETTE ASSEMBLY WITH TUBING LOOPS**

D556,909 S 12/2007 Reihanifam et al.
D600,792 S 9/2009 Eubanks et al.
7,608,053 B2 * 10/2009 Felt A61M 1/30
604/6.05

(71) Applicant: **Fenwal, Inc.**, Lake Zurich, IL (US)

D616,539 S 5/2010 McGill
D639,978 S 6/2011 Roos et al.
8,114,276 B2 2/2012 Childers et al.
D657,865 S * 4/2012 Williams D24/111
8,192,401 B2 6/2012 Morris et al.
D664,660 S * 7/2012 Hickey D24/169
D721,801 S * 1/2015 Mollstam D24/111
2006/0217651 A1 * 9/2006 Hutchinson A61M 1/3681
604/6.01

(72) Inventors: **Terry Chung**, Kildeer, IL (US); **Brian C. Case**, Lake Villa, IL (US); **Steven R. Katz**, Deerfield, IL (US); **Salvatore Manzella, Jr.**, Barrington, IL (US); **Gregory Pieper**, Spring Grove, IL (US); **Patrick Flanagan**, Algonquin, IL (US)

(73) Assignee: **Fenwal, Inc.**, Lake Zurich, IL (US)

2013/0331774 A1 12/2013 Farrell et al.
2014/0194809 A1 7/2014 Plahey et al.

(**) Term: **14 Years**

* cited by examiner

(21) Appl. No.: **29/514,466**

Primary Examiner — Anhdao Doan

(22) Filed: **Jan. 13, 2015**

(74) *Attorney, Agent, or Firm* — Cook Alex Ltd.

Related U.S. Application Data

(63) Continuation-in-part of application No. 29/472,722, filed on Nov. 15, 2013, now Pat. No. Des. 724,221.

(51) **LOC (10) Cl.** **24-01**

(52) **U.S. Cl.**
USPC **D24/169**

(58) **Field of Classification Search**
USPC D24/169, 186, 107, 108, 111, 216, 219, D24/232; 604/27, 29, 131, 132, 140, 141, 604/146, 6.01–6.05, 6.11, 6.13–6.16, 151
CPC A61M 1/28; A61M 1/281; A61M 1/282; A61M 1/3621; A61M 2205/12
See application file for complete search history.

(56) **References Cited**

U.S. PATENT DOCUMENTS

D257,689 S 12/1980 Riede
4,770,787 A * 9/1988 Heath A61M 1/3621
210/646
D350,823 S 9/1994 Lanigan
6,491,656 B1 * 12/2002 Morris A61M 1/3621
604/6.09

(57) **CLAIM**

The ornamental design for the cassette assembly with tubing loops, as shown and described.

DESCRIPTION

FIG. 1 is a top perspective view of a cassette assembly with tubing loops showing our new design;
FIG. 2 is a bottom perspective view thereof;
FIG. 3 is a front view of the cassette assembly with tubing loops of FIG. 1;
FIG. 4 is a rear view of the cassette assembly with tubing loops of FIG. 1;
FIG. 5 is end view taken from the right-hand side of FIG. 3;
FIG. 6 is an end view taken from the left-hand side of FIG. 3;
FIG. 7 is a top view of the of the cassette assembly with tubing loops of FIG. 1; and,
FIG. 8 is a bottom view of the of the cassette assembly with tubing loops of FIG. 1.
The broken lines in the drawing views are included for the purpose of illustrating portions of the cassette assembly with pump tubing that form no part of the claimed design.

1 Claim, 6 Drawing Sheets

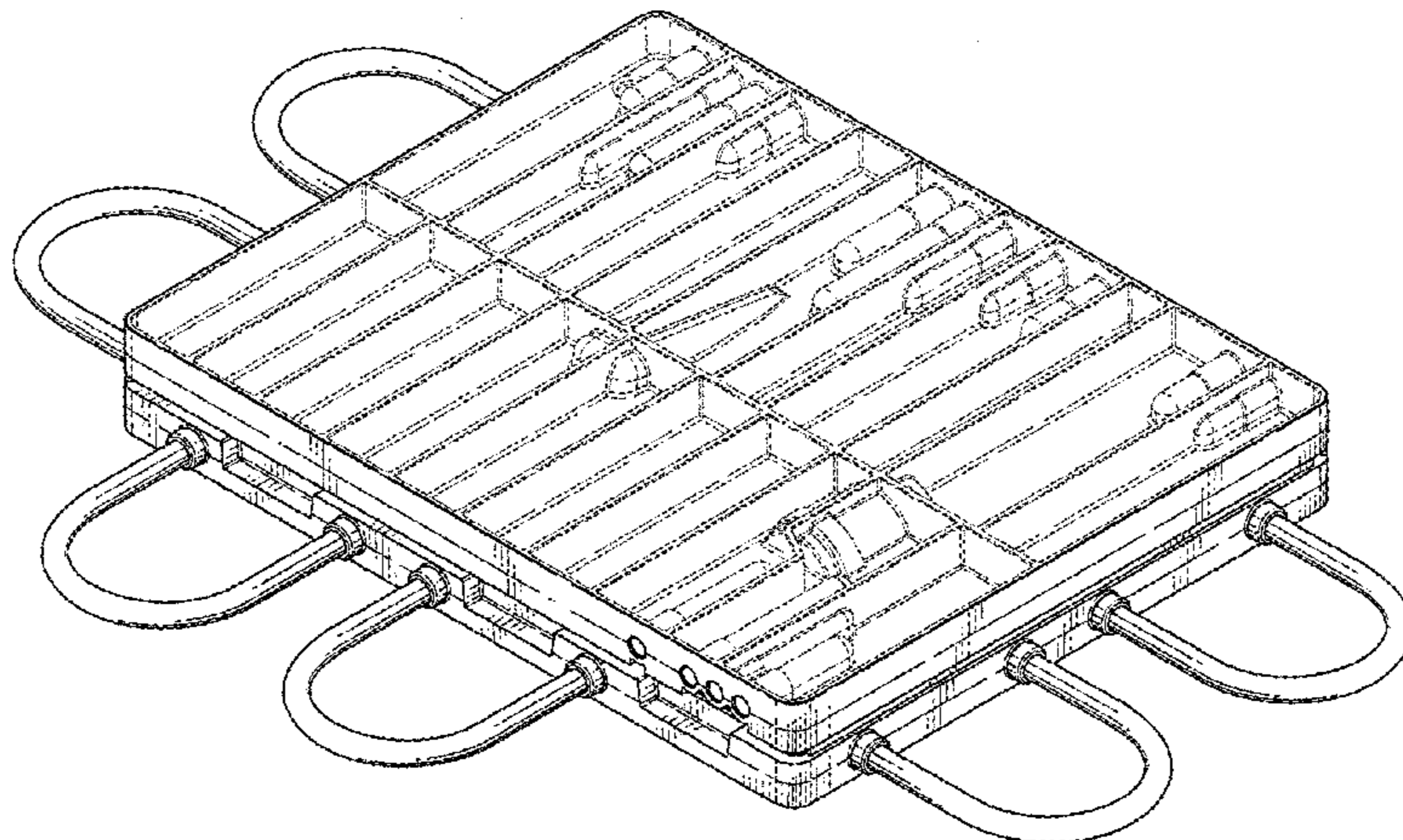

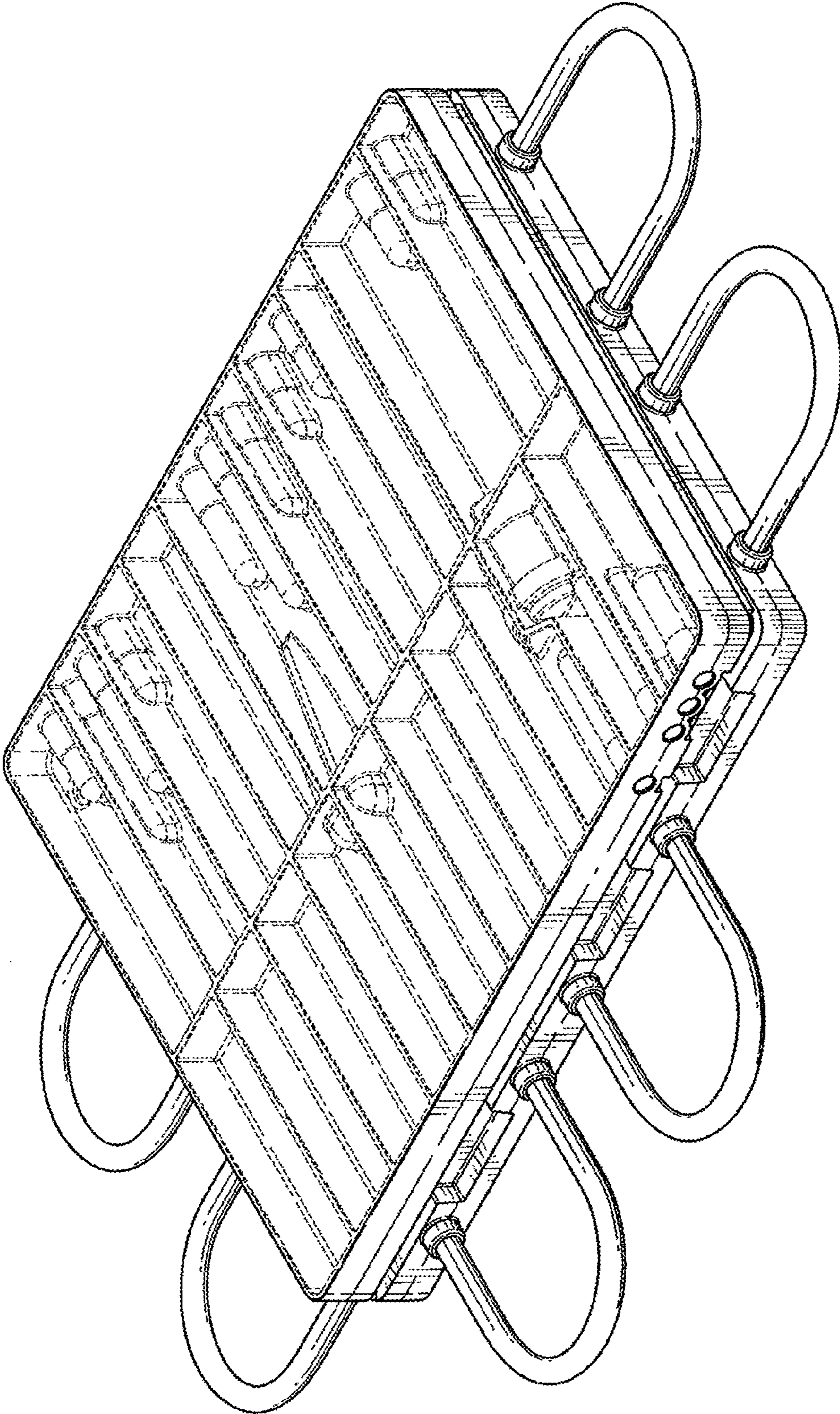

FIG. 1

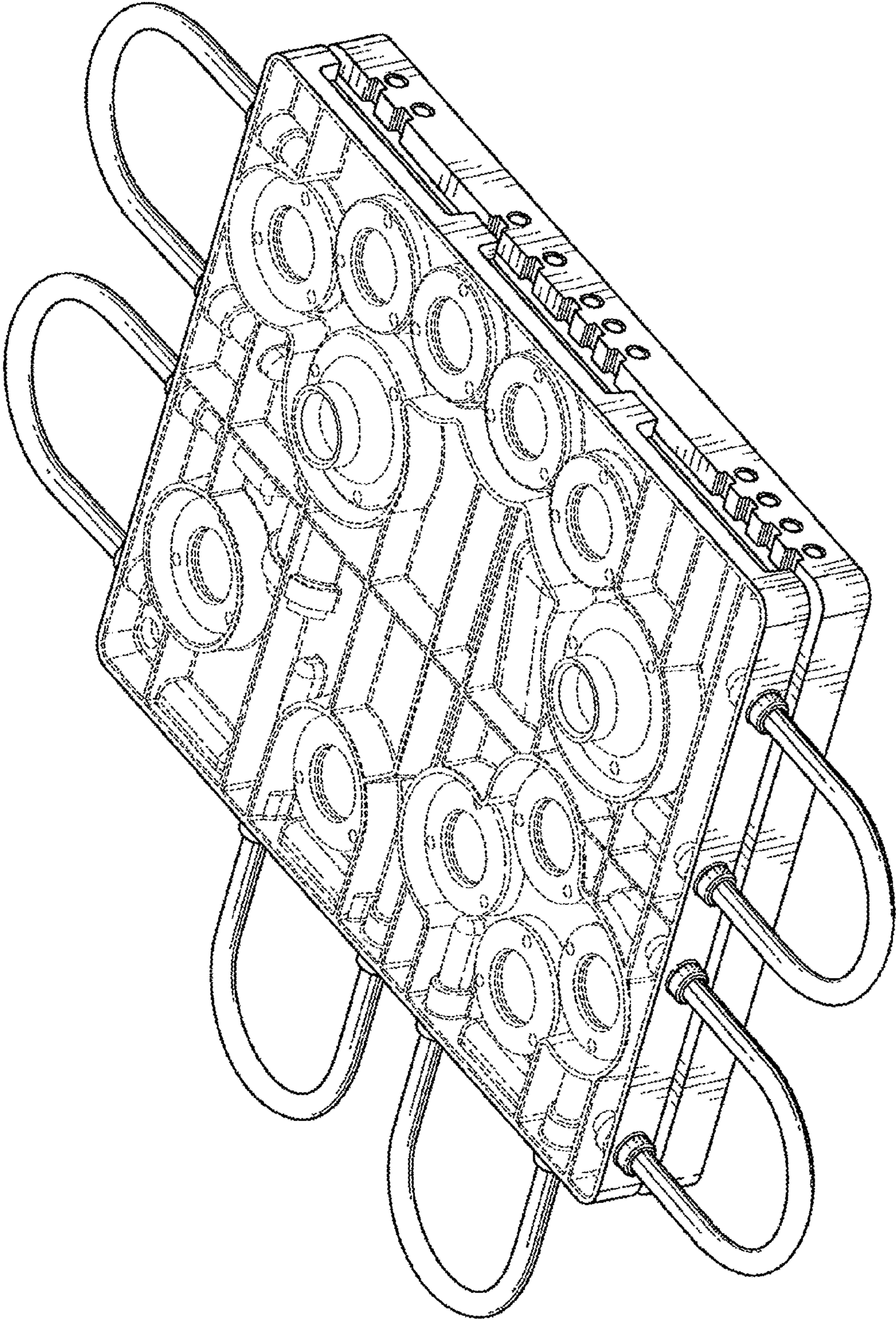

FIG. 2

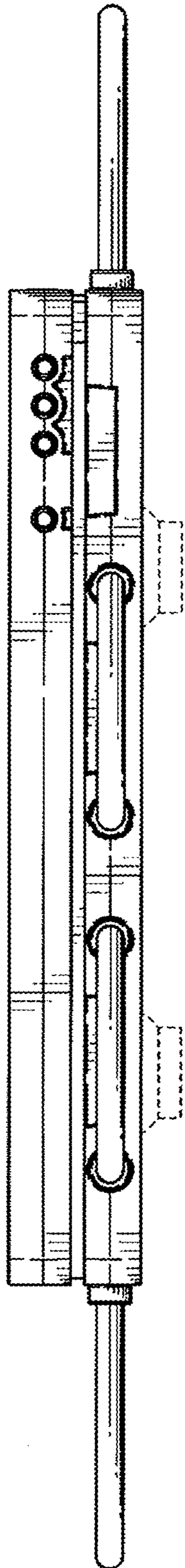

FIG. 3

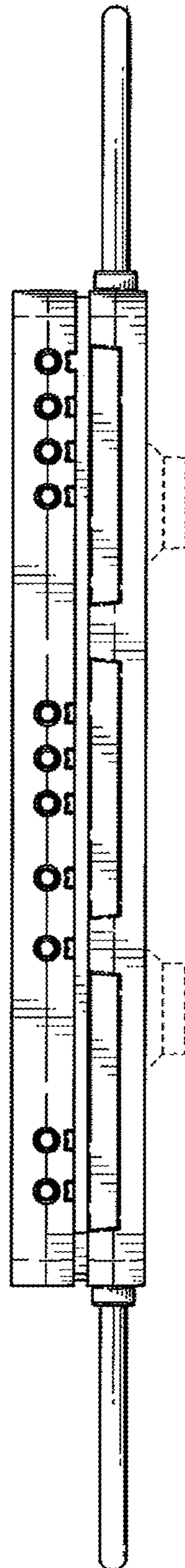

FIG. 4

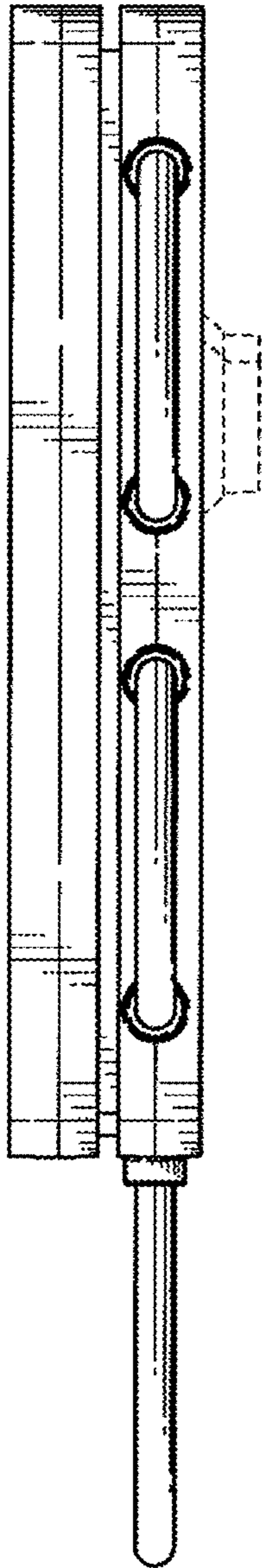

FIG. 5

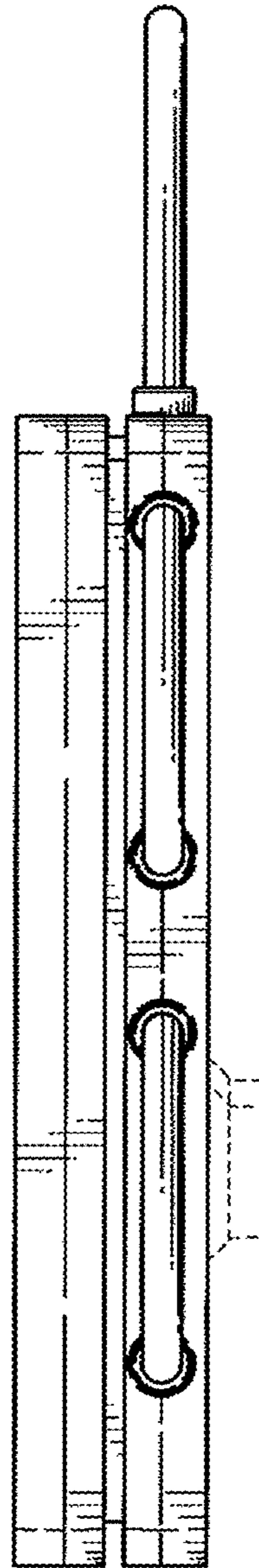

FIG. 6

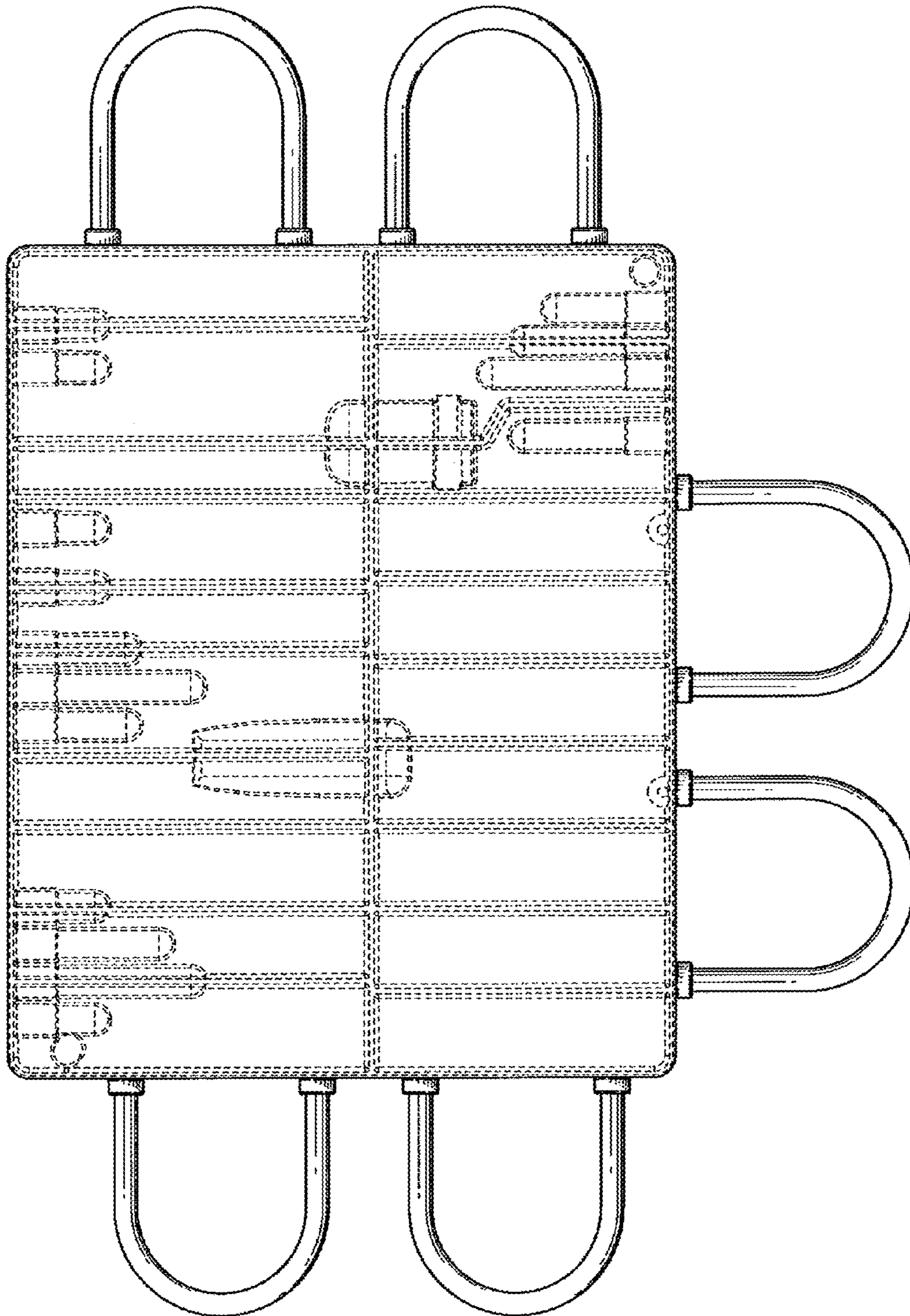

FIG. 7

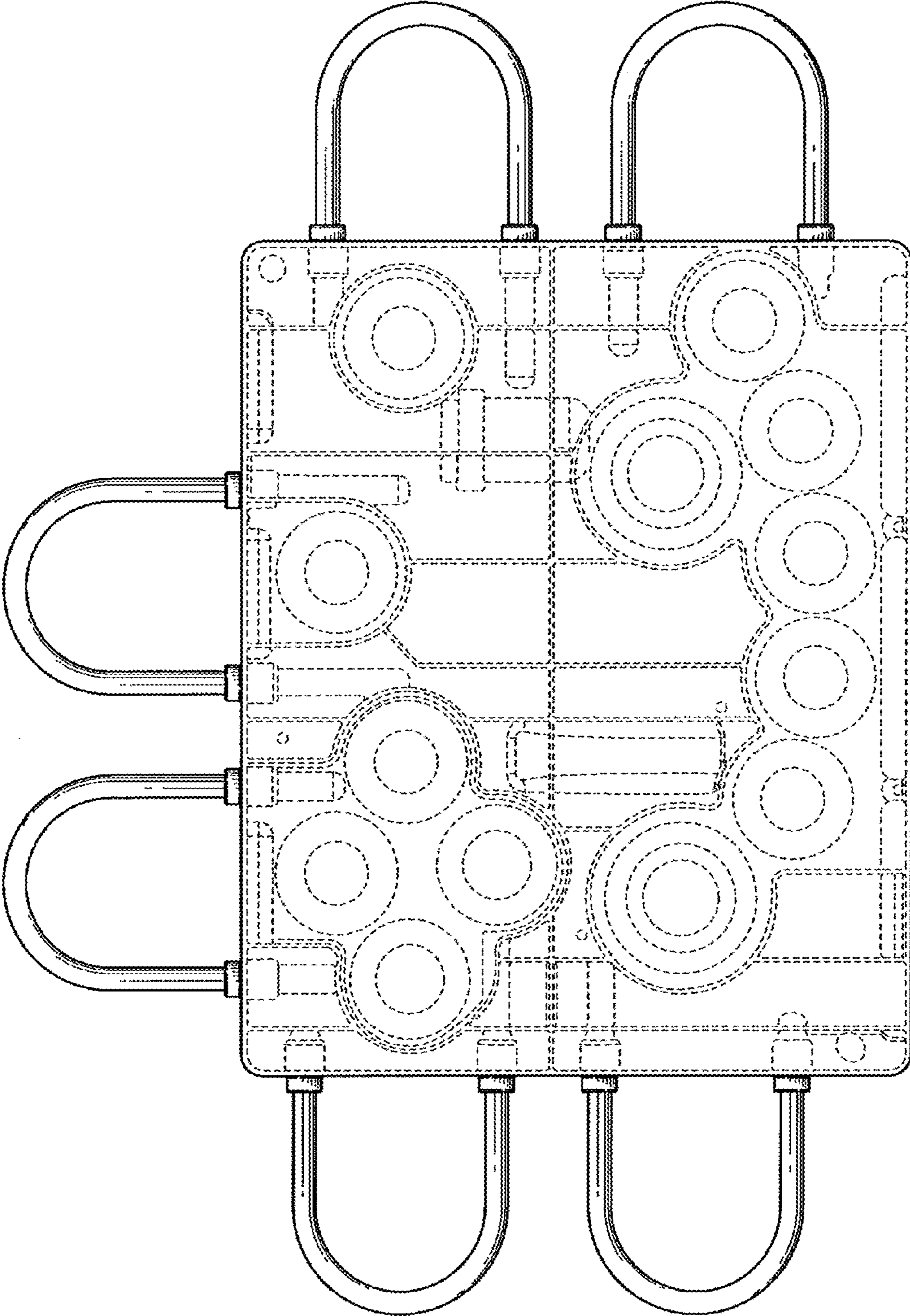

FIG. 8