



US00D752751S

(12) **United States Design Patent**
Radzinsky

(10) **Patent No.:** **US D752,751 S**
(45) **Date of Patent:** **** Mar. 29, 2016**

(54) **PROSTHETIC ADAPTOR** 5,988,727 A * 11/1999 Mueller B62J 17/04
224/448
(71) Applicant: **Vladimir Radzinsky**, Torrance, CA 7,033,400 B2 4/2006 Carrier
(US) 7,762,246 B2 * 7/2010 Telford F41B 11/52
124/49
(72) Inventor: **Vladimir Radzinsky**, Torrance, CA 8,568,489 B2 * 10/2013 Finlinson A61F 2/78
(US) 8,646,733 B2 2/2014 Radzinsky 417/480
(**) Term: **14 Years** (Continued)

(21) Appl. No.: **29/517,933**
(22) Filed: **Feb. 18, 2015**

FOREIGN PATENT DOCUMENTS

DE 10027760 A1 12/2001
EP 267347 A1 5/1988
EP 0976370 5/2000

Related U.S. Application Data

(60) Division of application No. 14/204,591, filed on Mar. 11, 2014, which is a continuation-in-part of application No. 14/162,087, filed on Jan. 23, 2014.
(51) **LOC (10) Cl.** **24-02**
(52) **U.S. Cl.**
USPC **D24/155**
(58) **Field of Classification Search**
USPC D24/155
CPC A61F 2/3859; A61F 2/38; A61F 2/389;
A61F 2/3886; A61F 2/60; A61F 2/66; A61F
2/76; A61F 2310/00023
See application file for complete search history.

OTHER PUBLICATIONS

A-525 / 4 Hole Rotating Based with Pyramid 98g Rated to 300 Lbs / 136 kg.
(Continued)

Primary Examiner — Susan Bennett Hattan
Assistant Examiner — Charles Hanson
(74) *Attorney, Agent, or Firm* — Fulwider Patton LLP

(57) **CLAIM**
The ornamental design for a prosthetic adaptor, as shown and described.

(56) **References Cited**

U.S. PATENT DOCUMENTS

621,638 A * 3/1899 Donaldson A61F 2/60
623/35
1,617,925 A 2/1927 Shrodes
5,047,063 A * 9/1991 Chen A61F 2/64
403/59
5,062,856 A * 11/1991 Sawamura A61F 2/68
623/24
5,571,211 A 11/1996 Hiemisch et al.
5,653,768 A 8/1997 Kania
5,779,735 A 7/1998 Molino
5,888,214 A 3/1999 Ochoa
5,888,232 A 3/1999 Taylor

DESCRIPTION

FIG. 1 is a perspective view of the prosthetic adaptor;
FIG. 2 is a top plan view of the prosthetic adaptor;
FIG. 3 is a front elevation view of the prosthetic adaptor;
FIG. 4 is a rear elevation view of the prosthetic adaptor;
FIG. 5 is a left elevation view of the prosthetic adaptor;
FIG. 6 is a right elevation view of the prosthetic adaptor; and,
FIG. 7 is a bottom plan view of the prosthetic adaptor taken along lines 2-7 of FIG. 3.
The broken line showing is included for the purpose of illustrating environment and forms no part of the claimed design.

1 Claim, 3 Drawing Sheets

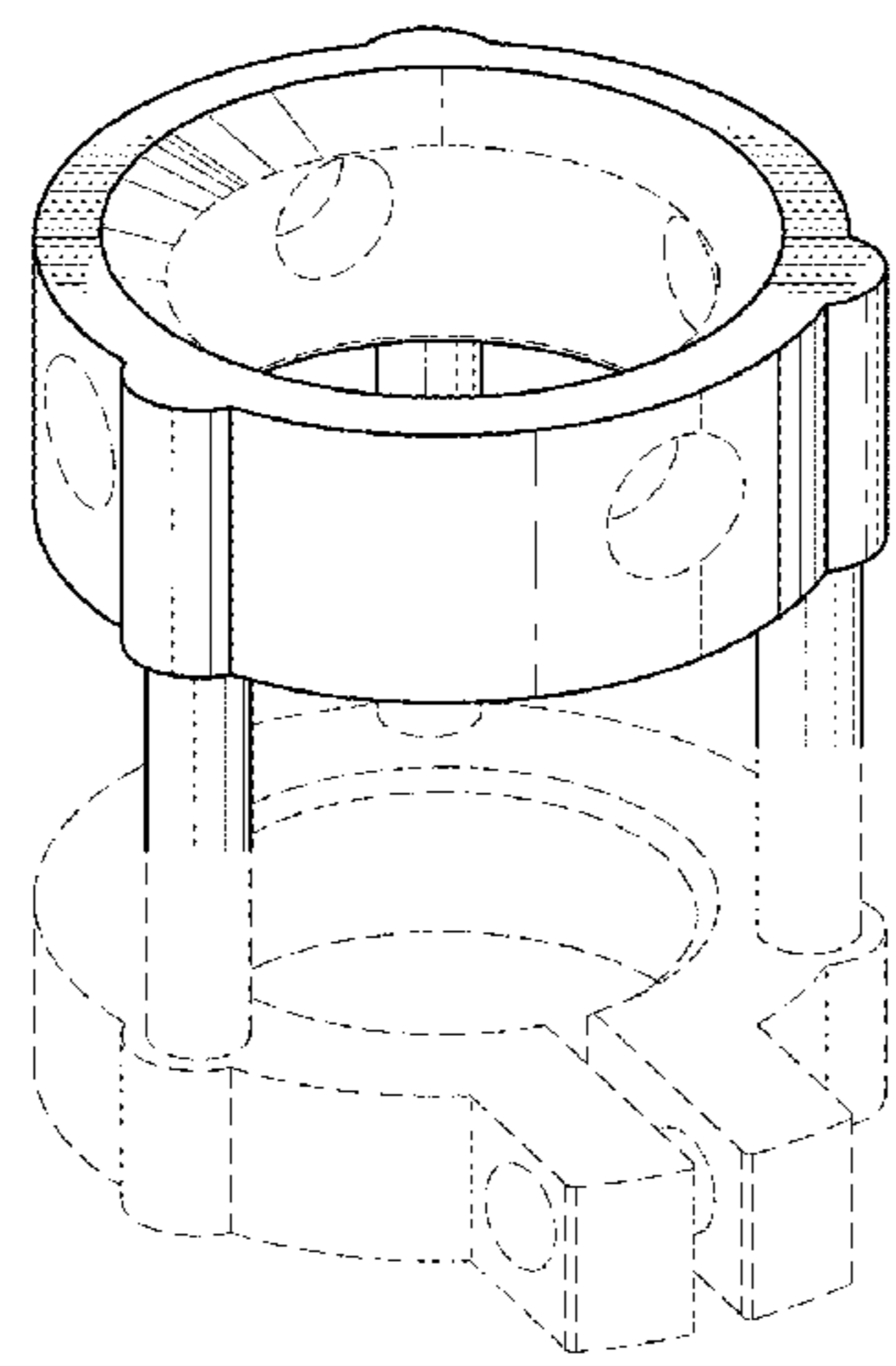

(56)

References Cited

U.S. PATENT DOCUMENTS

9,017,419 B1 * 4/2015 Landry H02K 7/10
310/156.01
2005/0033451 A1 2/2005 Aigner et al.
2005/0049720 A1 3/2005 Benson
2008/0228288 A1 9/2008 Nelson et al.
2008/0298886 A1 12/2008 Chen
2012/0018594 A1 1/2012 Radzinsky

OTHER PUBLICATIONS

SK&P Website: [http://www.simplyknobsandpulls.com/bargain-bin/A-692 HD 4 Hole Connector without Pyramid Hole 56g Rated to 350 lbs / 159 kg](http://www.simplyknobsandpulls.com/bargain-bin/A-692-HD-4-Hole-Connector-without-Pyramid-Hole-56g-Rated-to-350-lbs-159-kg).
Derwent Abstract of SU564862. Kondrashin. Aug. 22, 1977.
Endolite male pyramid. Verified by the wayback machine Sep. 28, 2013.
Kingsley SACH foot adapter. Verified by the wayback machine May 5, 2007.

Medi Clever Bones (1, 2 are different views). Verified by the wayback machine Jul. 20, 2013.
English translation of EP0976370 from Espacenet.
Angarami, Geraldo. An Efficient Low Cost Prosthetic Structural System. Journal of Prosthetics and Orthotics. 1998, vol. 1, Num 2, 86-91.
Medi Clever Bones. Medi Product Website.
Edwards, Mark. Solutions for the Prosthetic Fitting of Bariatric Patients Using Ottobock Components. The Academy Today. Jan. 2013.
Derwent Abstract of DE20112494. Published Nov. 8, 2001. Medi Bayreuth Weihermueller and Voigtmann.
BP3 Neuropsychogenic by Dycor Manufacturing. <http://www.dycormfg.com/newprods.html>.
An Efficient Low Cost Prosthetic Structural System, Geraldo r. Angarami, C.P. / Carlos E. Samaria; Source: Journal of Prosthetics and Orthotics 1989; vol. 1, Num 2, p. 86; URL: [http://www.oandp.org/ipo/library/1989 02 086.asp](http://www.oandp.org/ipo/library/1989-02-086.asp).

* cited by examiner

FIG. 1

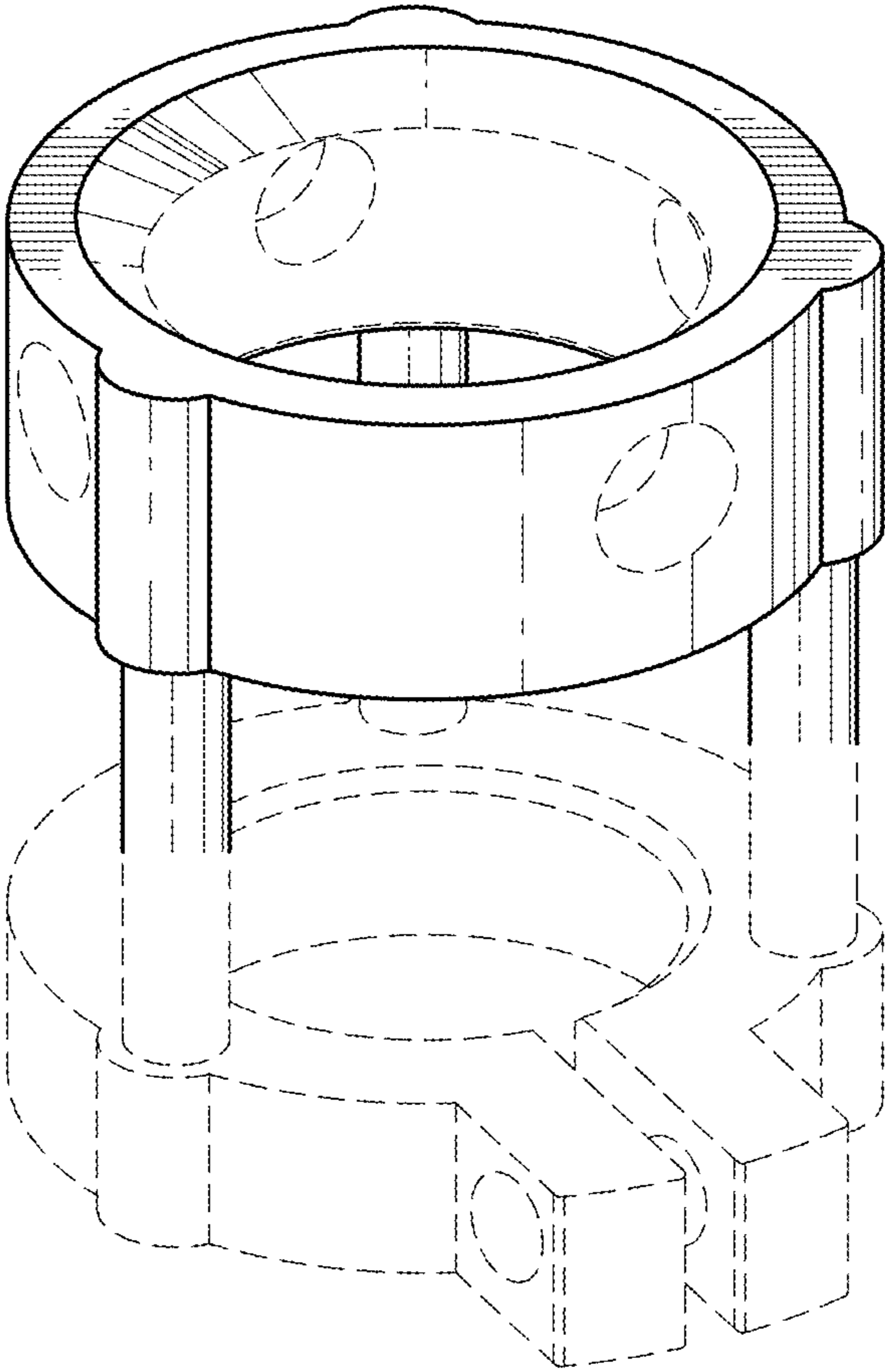
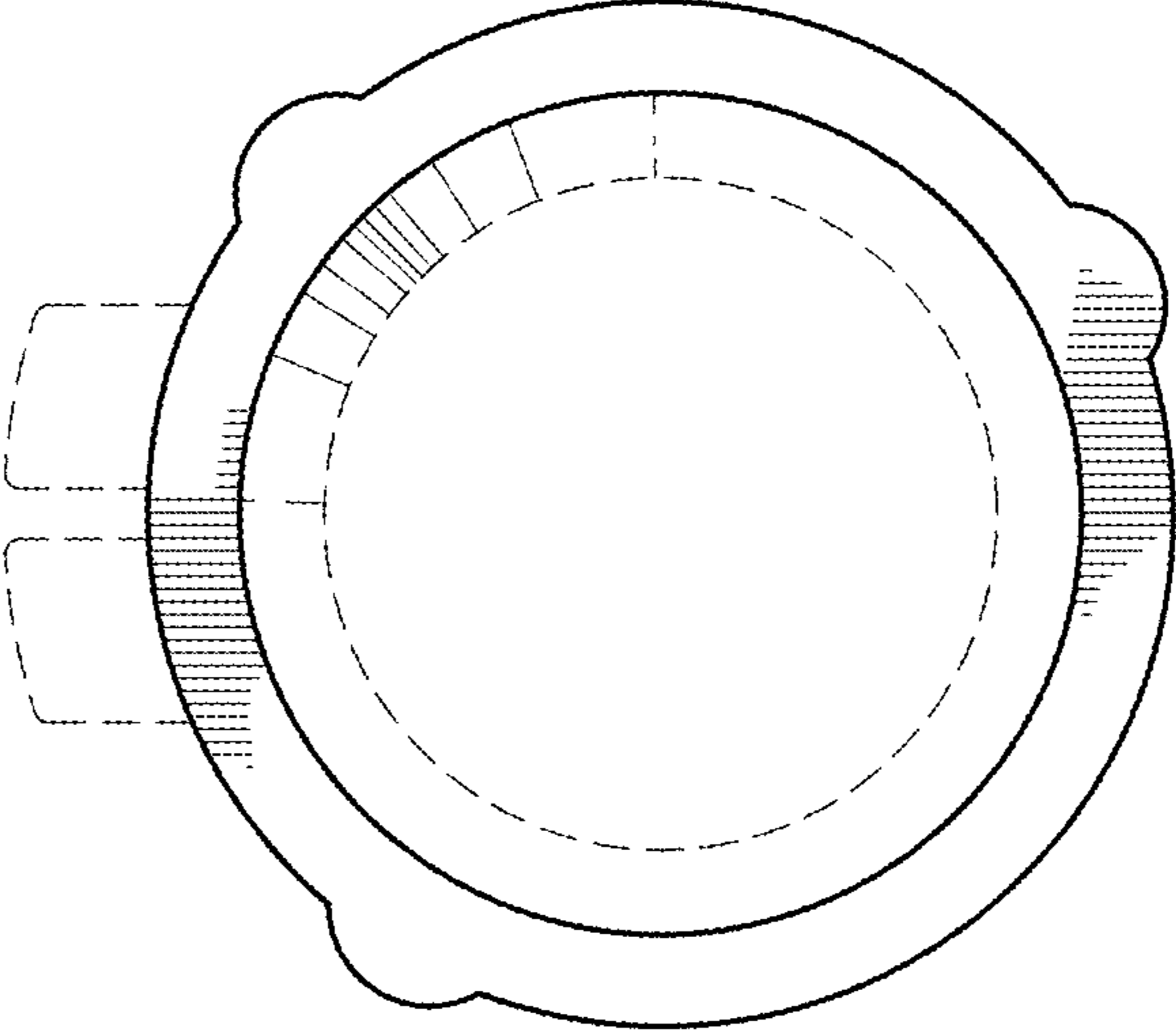

FIG. 2



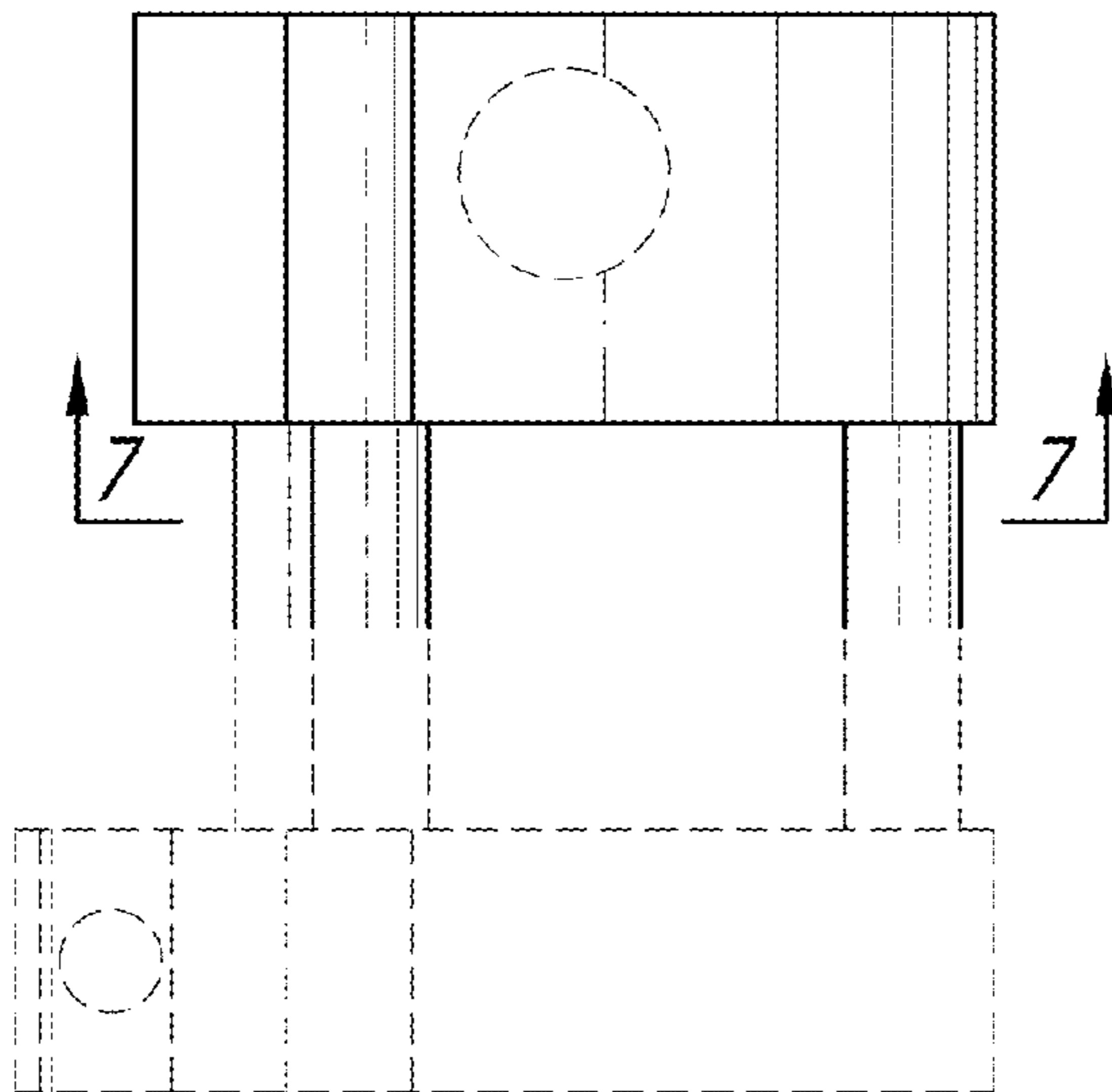

FIG. 3

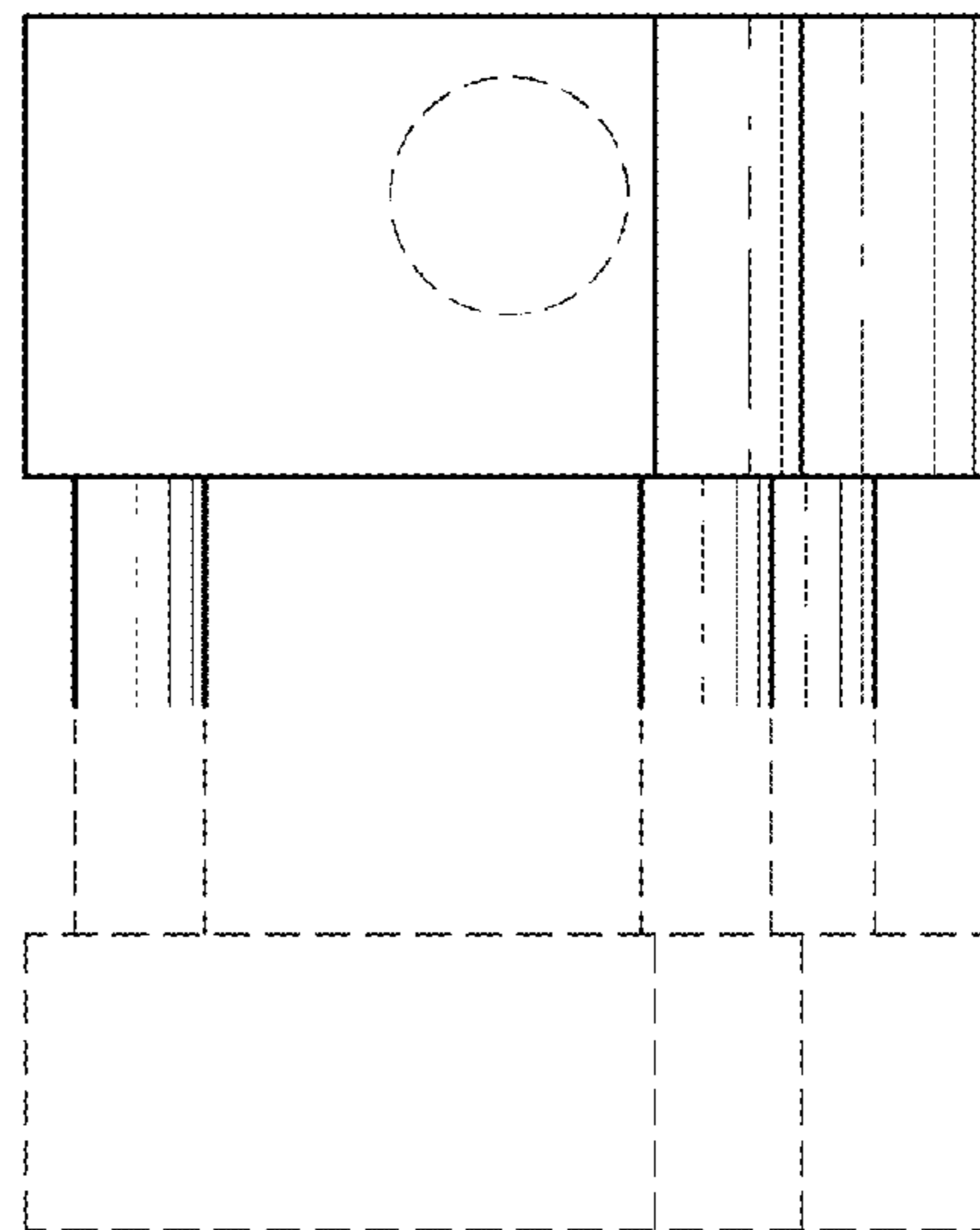

FIG. 4

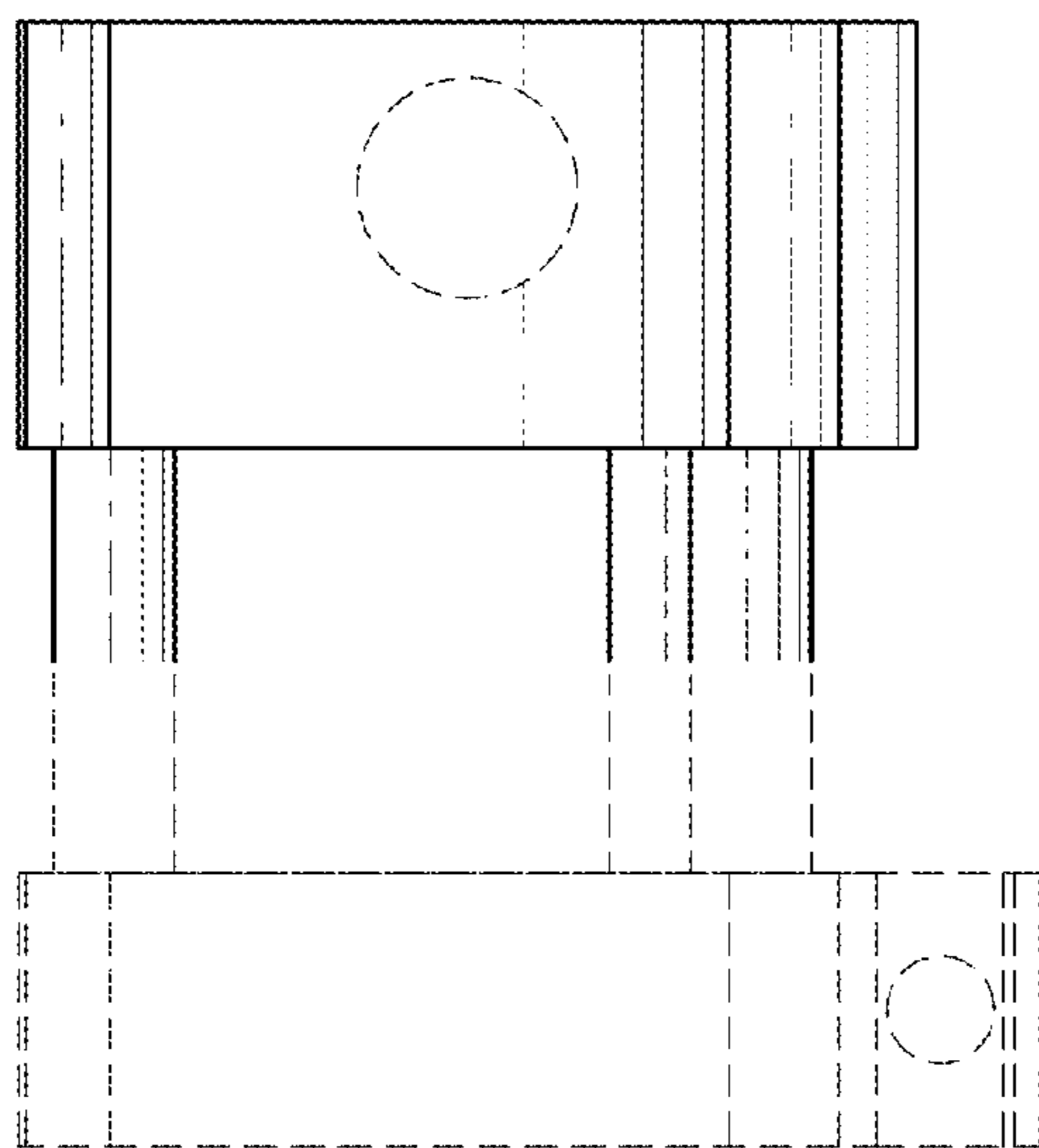

FIG. 5

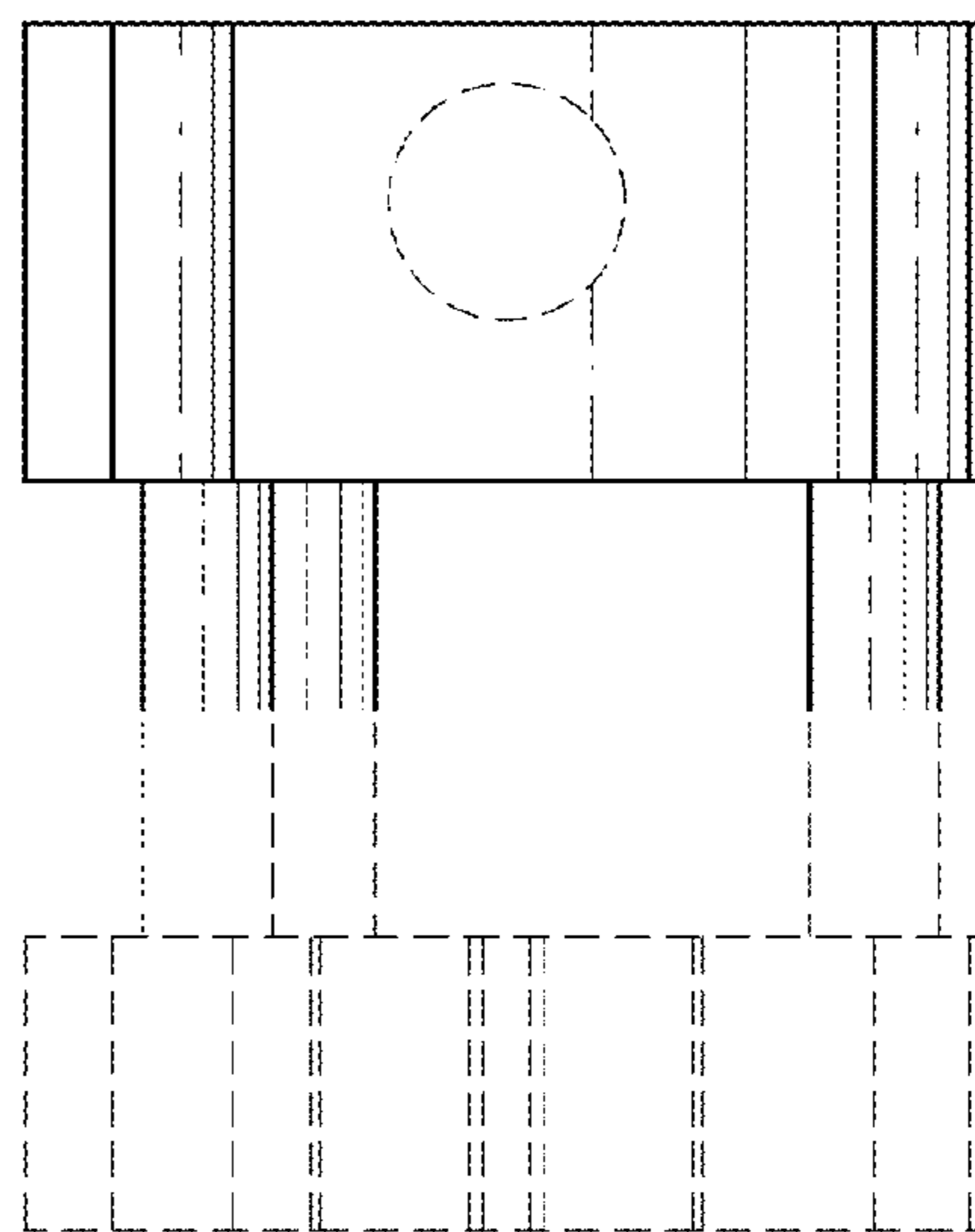

FIG. 6

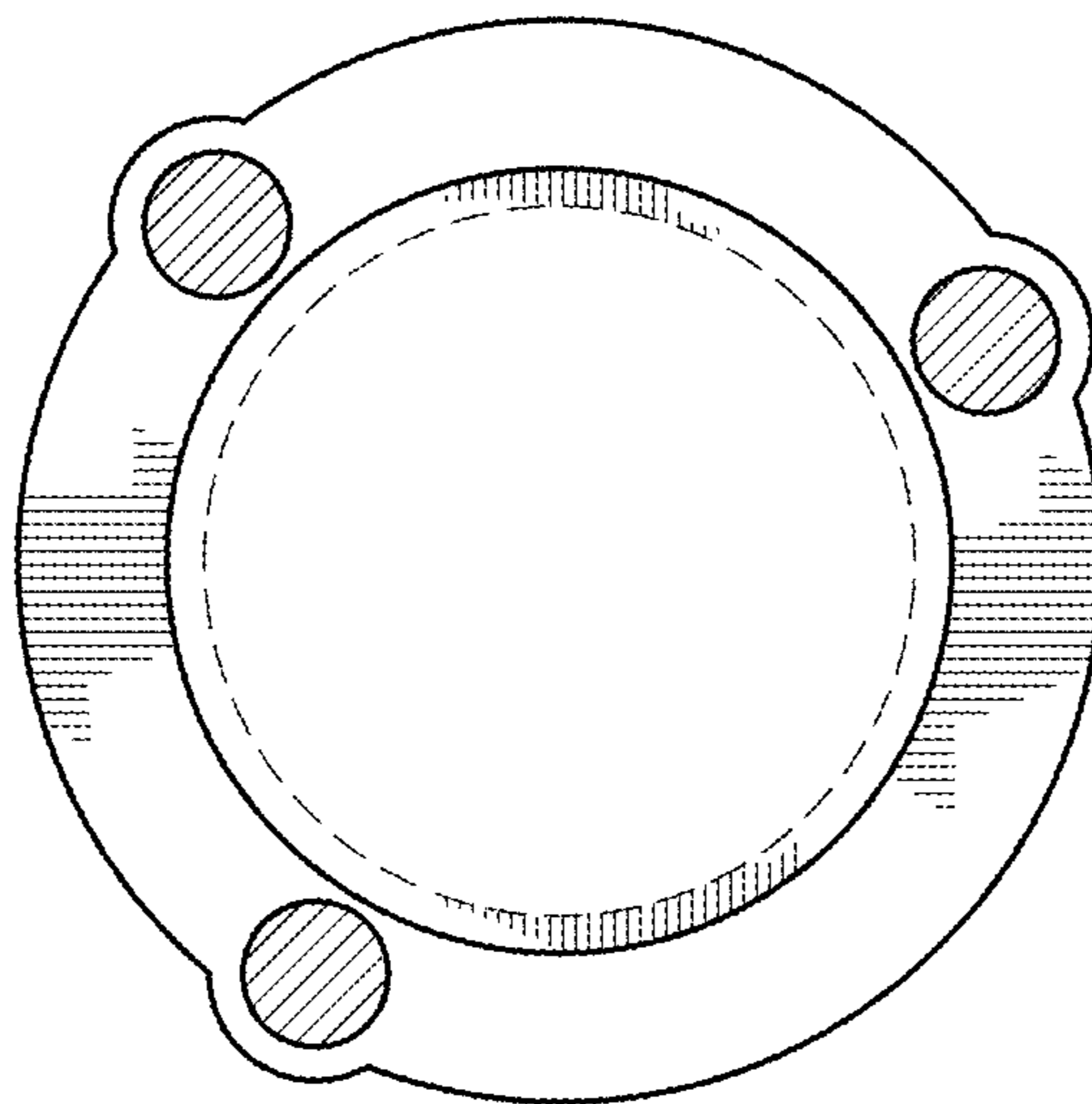

FIG. 7