



US00D752502S

(12) **United States Design Patent**
Paulino et al.

(10) **Patent No.:** **US D752,502 S**
(45) **Date of Patent:** **** Mar. 29, 2016**

(54) **PASSENGER SERVICE UNIT**

(71) Applicant: **EMBRAER S.A.**, São José dos Campos, SP (BR)

(72) Inventors: **Amauri Paulino**, São José dos Campos (BR); **Sergio Luiz Abdalla Gomide**, São José dos Campos (BR); **Gustavo Selofite De Arruda**, São José dos Campos (BR); **Nilmar César Ferreira**, São José dos Campos (BR); **Luciano Dos Santos Ribeiro**, São José dos Campos (BR); **Demétrio Andrade De Campos**, São José dos Campos (BR); **Sergio Augusto Meireles Filho**, São José dos Campos (BR); **Frederico Lara De Oliveira**, São José dos Campos (BR); **Douglas Gonçalves De Albuquerque**, São José dos Campos (BR); **Helio Albino**, São José dos Campos (BR); **André Duarte Stein**, São José dos Campos (BR); **Paul Priestman**, London (GB); **Daniel MacInnes**, London (GB); **Luciano Ricardo Magalhães Da Silva**, São José dos Campos (BR); **Ricardo Rosa Macêdo**, São José dos Campos (BR)

(73) Assignee: **EMBRAER S.A.**, São José Dos Campo, SP (BR)

(**) Term: **14 Years**

(21) Appl. No.: **29/469,015**

(22) Filed: **Oct. 4, 2013**

(51) **LOC (10) Cl.** **12-07**

(52) **U.S. Cl.**
USPC **D12/345**

(58) **Field of Classification Search**

USPC D12/319–345, 195, 418
CPC B64D 11/00; B64D 11/0015; B64D 2011/0053; B64D 2013/003; B60Q 3/00; B60Q 3/02

See application file for complete search history.

(56) **References Cited**

U.S. PATENT DOCUMENTS

3,370,813 A * 2/1968 Albertine et al. 244/118.5
D213,144 S * 1/1969 Kraus et al. D12/195

(Continued)

Primary Examiner — Martie K Holtje

(74) *Attorney, Agent, or Firm* — Nixon & Vanderhye P.C.

(57) **CLAIM**

The ornamental design for “passenger service unit,” as shown and described.

DESCRIPTION

FIG. 1 is a bottom left perspective view of a passenger service unit showing our new design,

FIG. 2 is an enlarged perspective view of the encircled portion “2” in FIG. 1,

FIG. 3 is a bottom right perspective view thereof,

FIG. 4 is a bottom plan view thereof; and,

FIG. 5 is a right side perspective view thereof.

The structure depicted by broken lines in the drawings has been shown for the purpose of illustrating environment that forms no part of the claimed design.

The dot-dashed lines encircling the FIG. 2 view represent a boundary that forms no part of the claimed design.

1 Claim, 3 Drawing Sheets

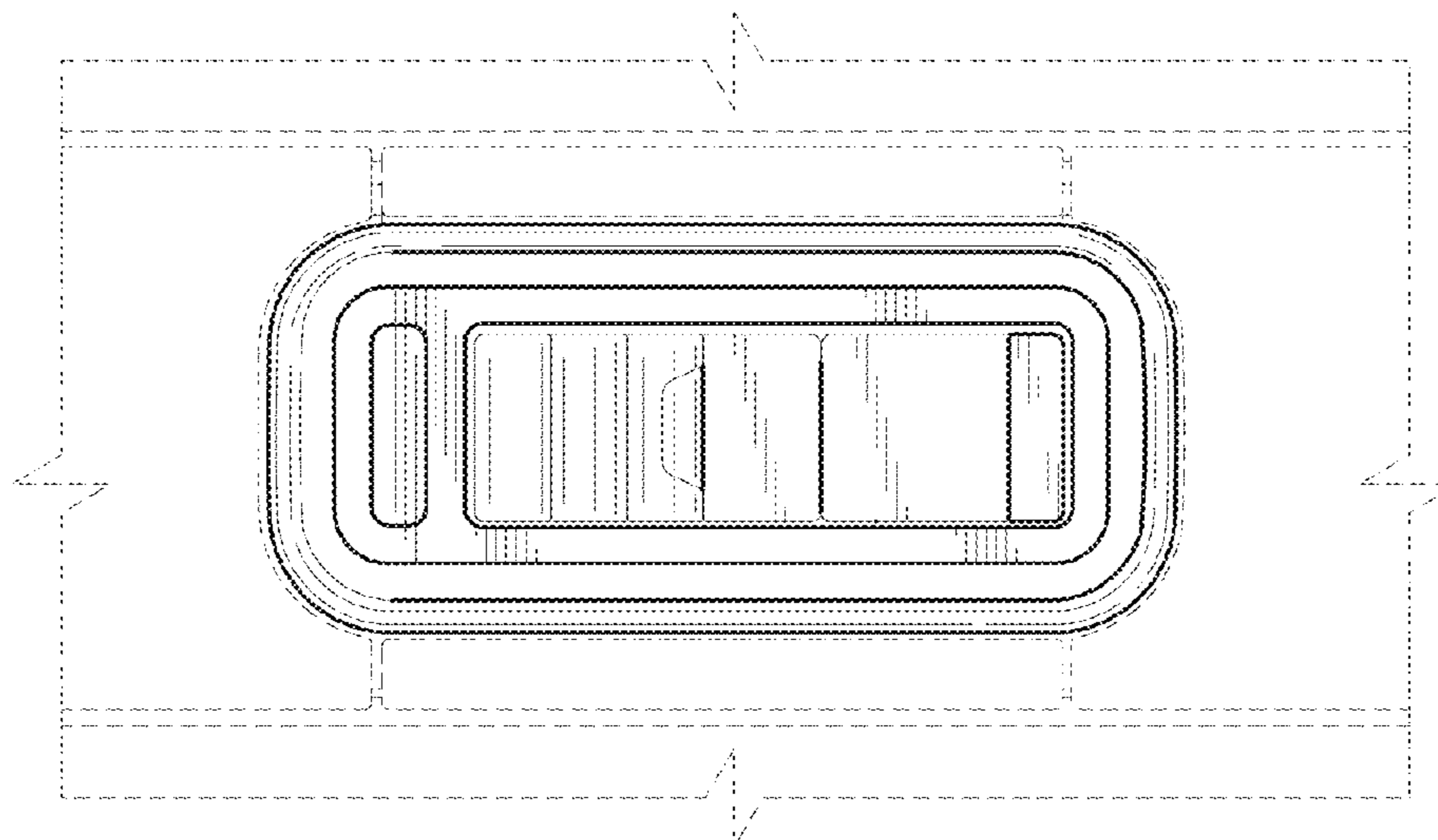

(56)

References Cited

U.S. PATENT DOCUMENTS

D244,018 S * 4/1977 Greiss et al. D12/195
D259,038 S * 4/1981 Smith D12/195
D281,940 S * 12/1985 Steventon et al. D6/492
D339,780 S * 9/1993 Burdick D12/418
5,707,028 A * 1/1998 Roeper 244/118.5
6,454,209 B1 * 9/2002 Bock et al. 244/118.5

D600,623 S * 9/2009 Fiedler et al. D12/345
D613,669 S * 4/2010 Collins et al. D12/345
D624,481 S * 9/2010 Schuephaus et al. D12/345
D624,483 S * 9/2010 Schuephaus et al. D12/345
D628,529 S * 12/2010 Fiedler et al. D12/345
D669,013 S * 10/2012 Schreuder D12/345
D673,892 S * 1/2013 Stephan et al. D12/345
2012/0032027 A1 * 2/2012 Gehm et al. 244/118.5

* cited by examiner

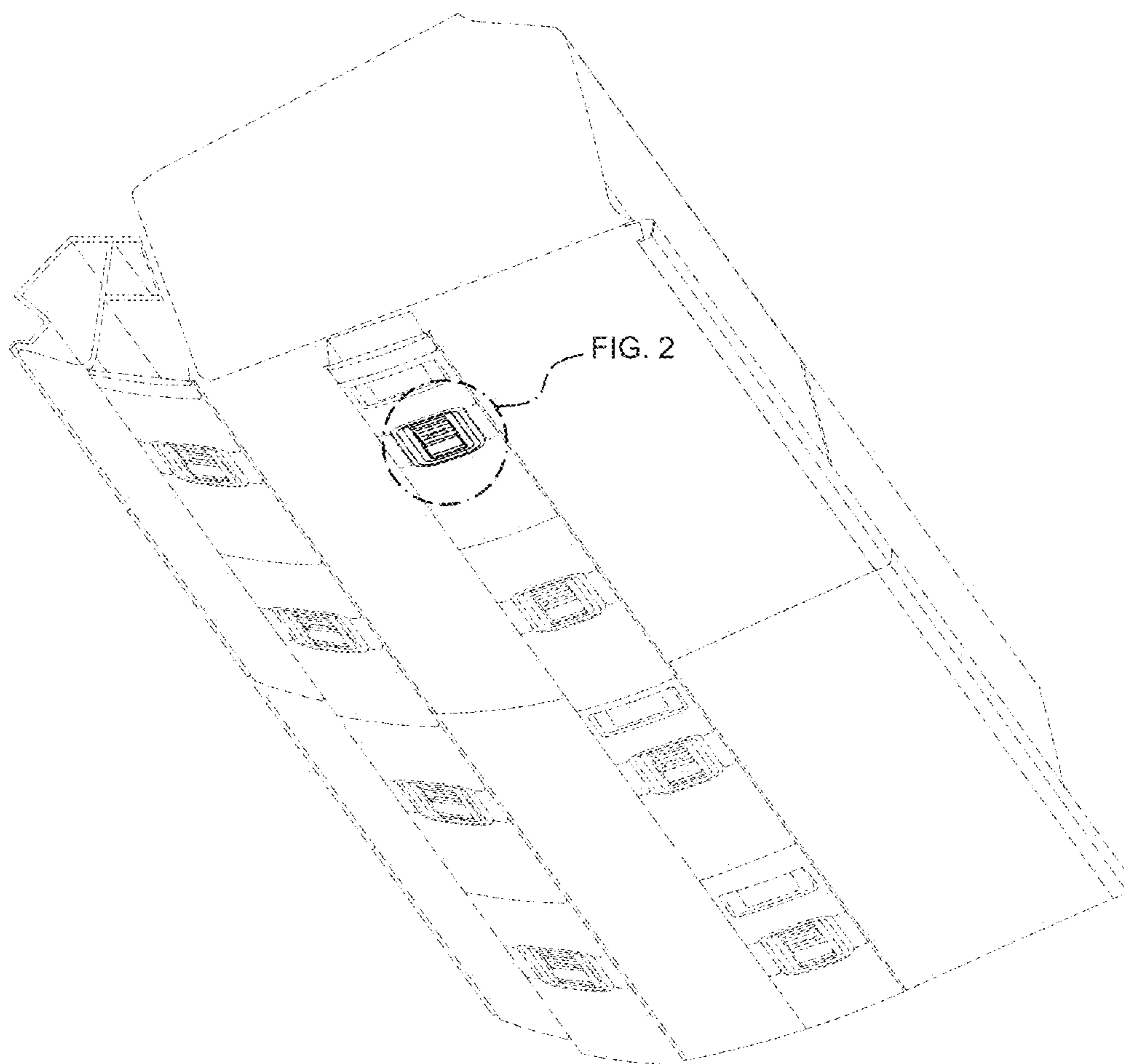

FIG. 1

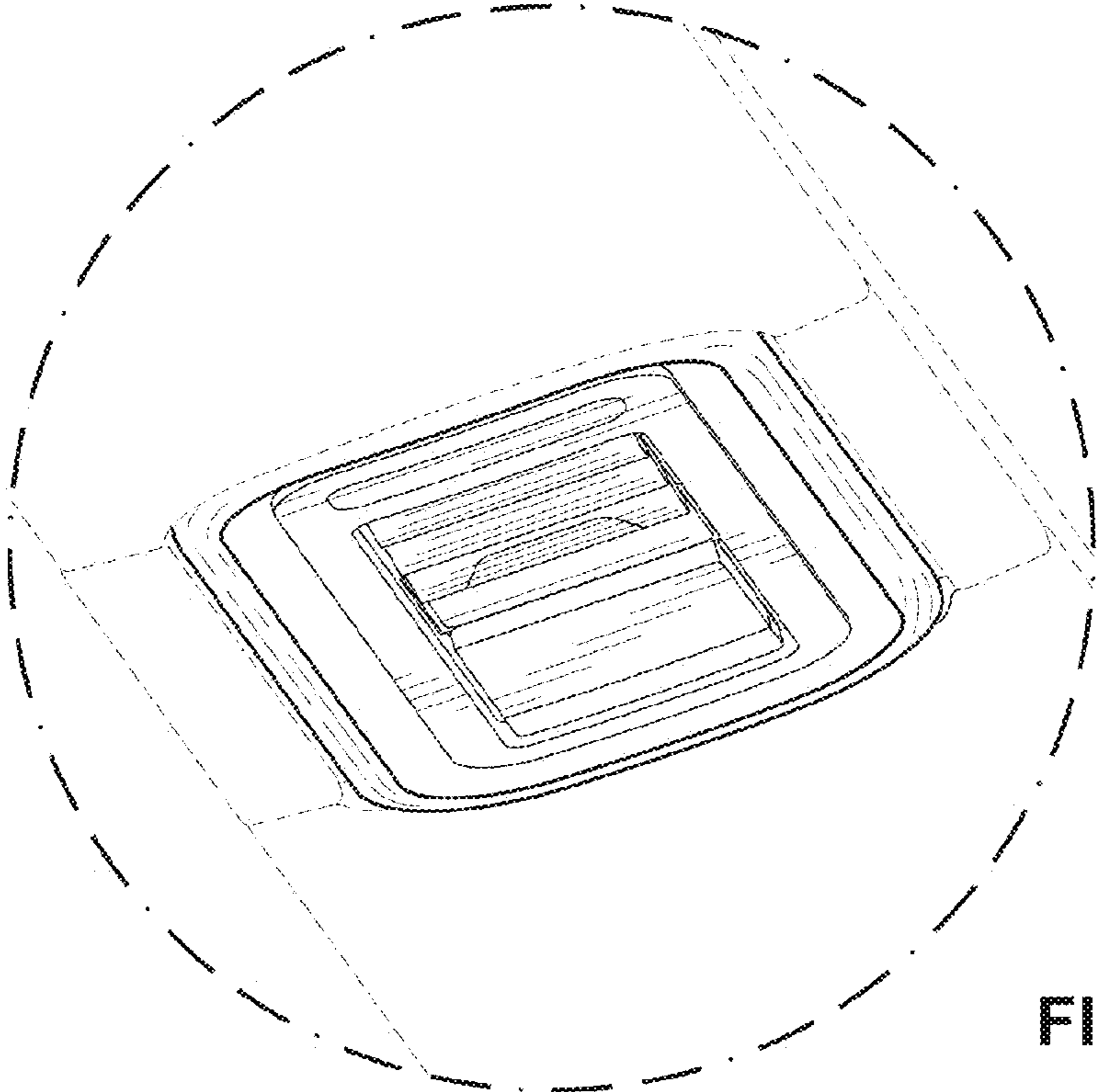

FIG. 2

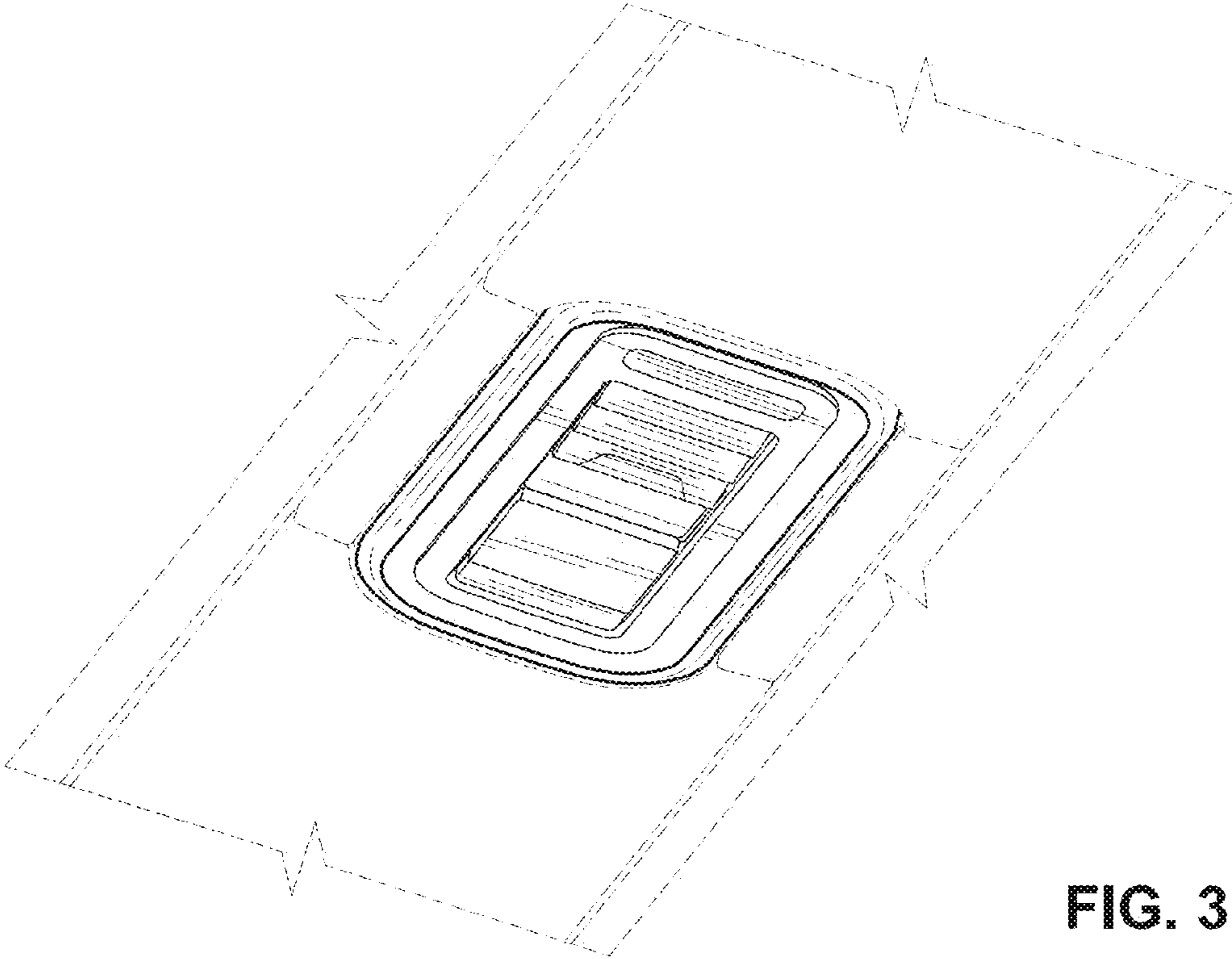

FIG. 3

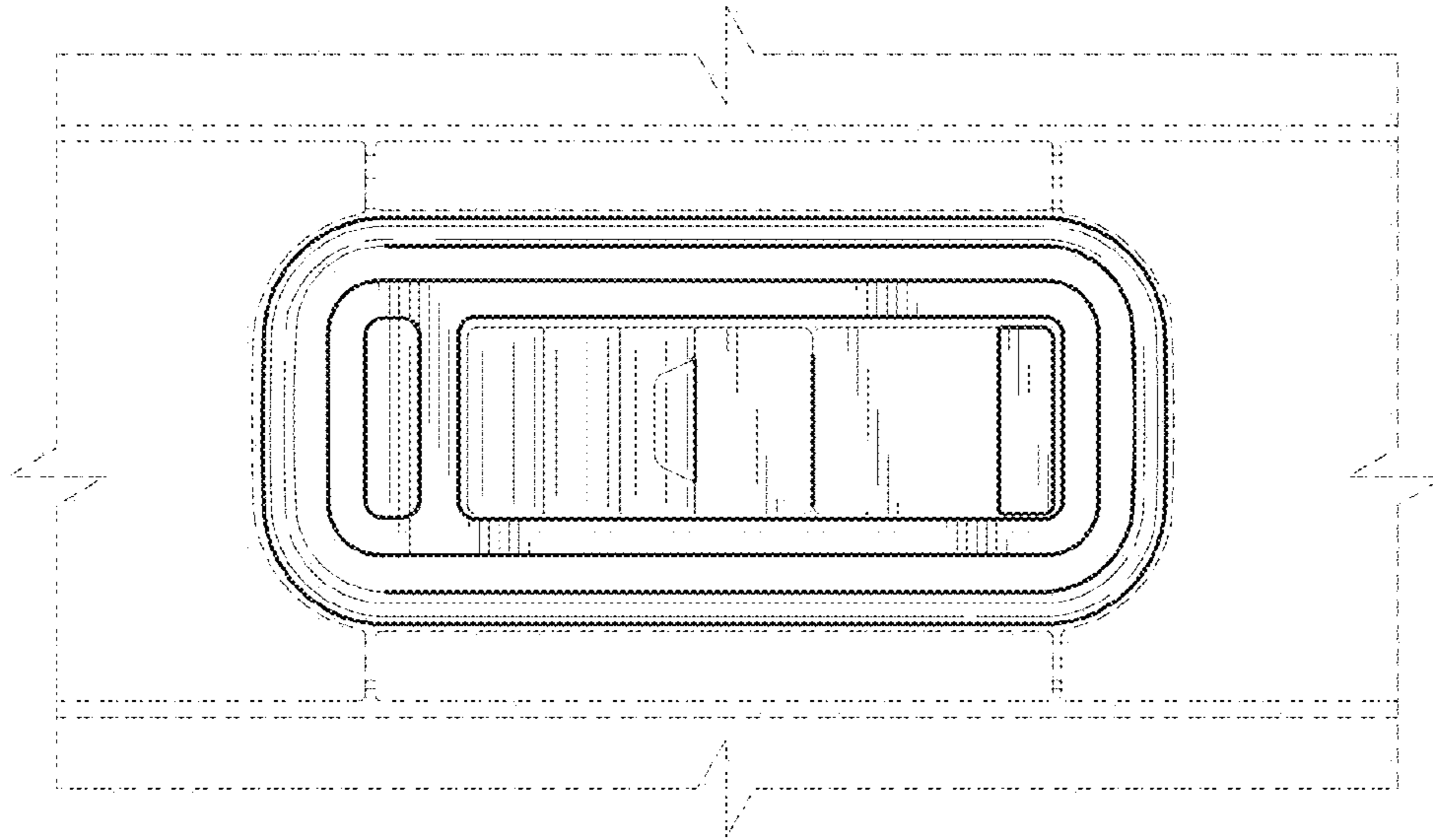

FIG. 4

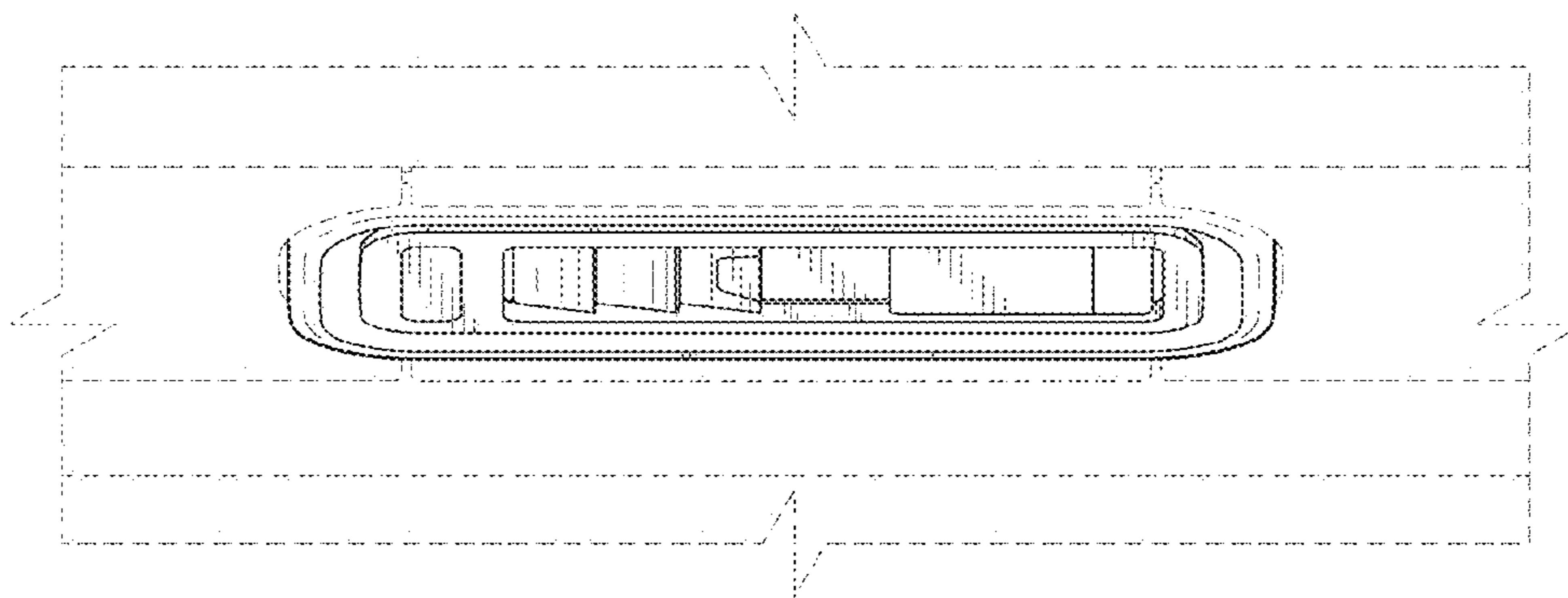

FIG. 5