



US00D752442S

(12) **United States Design Patent**
O'Donahue

(10) **Patent No.:** **US D752,442 S**

(45) **Date of Patent:** **** Mar. 29, 2016**

(54) **BOTTLE**

(71) Applicant: **Bath & Body Works Brand Management, Inc.**, Reynoldsburg, OH (US)

(72) Inventor: **Samuel Dominic O'Donahue**, New York, NY (US)

(73) Assignee: **Bath & Body Works Brand Management, Inc.**, Reynoldsburg, OH (US)

(**) Term: **14 Years**

(21) Appl. No.: **29/493,400**

(22) Filed: **Jun. 9, 2014**

(51) **LOC (10) Cl.** **09-01**

(52) **U.S. Cl.**
USPC **D9/529**; D9/558

(58) **Field of Classification Search**
USPC D9/435, 446-447, 449, 516, 529, 530, D9/542, 549, 558, 575, 682, 686, D9/688-692; 215/235-237, 379, 381-383; 220/324, 660, 669, 675, 810, 831
CPC B65D 1/00; B65D 1/02; B65D 23/00; B65D 39/00

See application file for complete search history.

(56) **References Cited**

U.S. PATENT DOCUMENTS

D265,459 S *	7/1982	Picot	D9/448
D271,244 S *	11/1983	Martinez	D28/5
D491,456 S *	6/2004	Cagle	D9/687
D510,527 S *	10/2005	Tune	D9/684
D528,012 S *	9/2006	Snyder	D9/529
D530,621 S *	10/2006	Rashid	D9/686
D547,189 S *	7/2007	Legros	D9/521
D590,264 S *	4/2009	Schwartz	D9/529
D598,753 S *	8/2009	Schwartz	D9/435
D609,100 S *	2/2010	Licari	D9/522
D633,390 S *	3/2011	Toh	D9/516
D637,647 S *	5/2011	Allison	D19/73

D638,715 S *	5/2011	Albaum	D9/529
D644,313 S *	8/2011	Westphal	D23/366
D644,516 S *	9/2011	Howell	D9/435
D650,686 S *	12/2011	de Cleir	D9/529
D655,199 S *	3/2012	Ciriani	D9/686
D656,409 S *	3/2012	Tadmor	D9/687
D663,893 S *	7/2012	Hosler	D28/7
D693,690 S *	11/2013	Wakui	D9/516
D698,248 S *	1/2014	Lambrecht	D9/444
D723,375 S *	3/2015	Brune	D9/449
2010/0147864 A1 *	6/2010	Howes	B65D 11/04 220/802

OTHER PUBLICATIONS

Google Search URL<http://www.amazon.com/gp/product/B012C5E4V6/ref=pd_lpo_sbs_dp_ss_3?pf_rd_p=1944687542&pf_rd_s=lpo-top-stripe-1&pf_rd_t=201&pf_rd_i=B00VO693DE&pf_rd_m=ATVPDKIKZ0DER&pf_rd_r=0K20RR0FYZP6922N4XZ7[Date searched Sep. 11, 2015].*

* cited by examiner

Primary Examiner — Philip S Hyder

Assistant Examiner — Keith Frank

(74) *Attorney, Agent, or Firm* — Andrus Intellectual Property Law, LLP

(57) **CLAIM**

The ornamental design for a bottle, as shown and described.

DESCRIPTION

FIG. 1 is a front perspective view of a bottle;
FIG. 2 is a front view thereof;
FIG. 3 is a back view thereof;
FIG. 4 is a left side view thereof;
FIG. 5 is a right side view thereof;
FIG. 6 is a top view thereof;
FIG. 7 is a bottom view thereof; and,
FIG. 8 is a front perspective view thereof showing a cap of the bottle in an alternative position.
The broken lines in FIGS. 7-8 represent subject matter that forms no part of the claimed design shown therein.

1 Claim, 6 Drawing Sheets

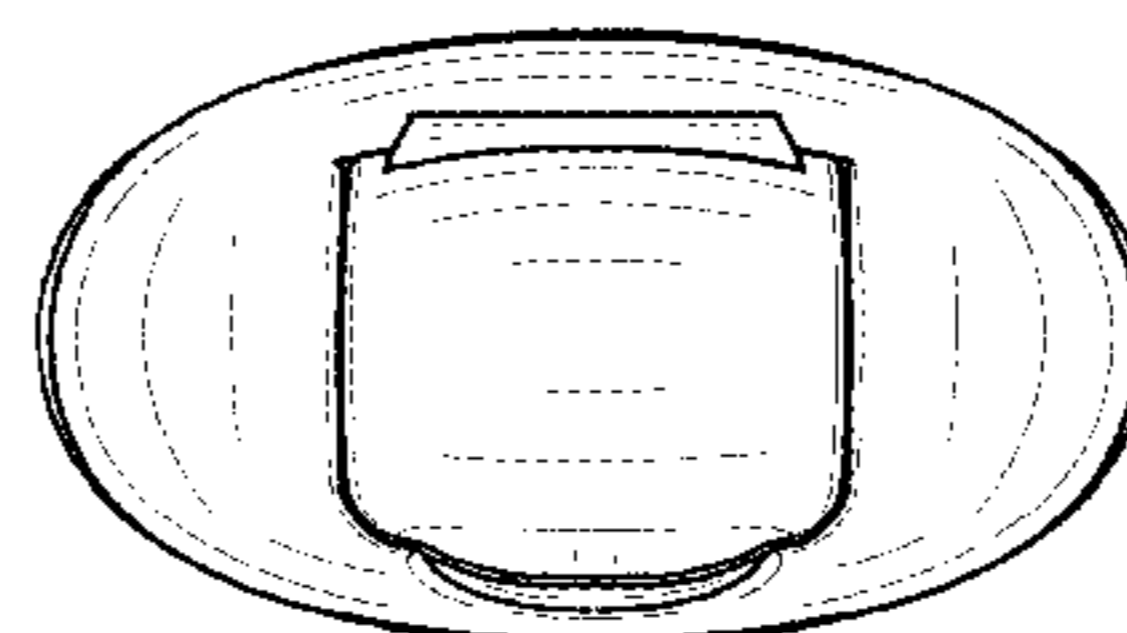
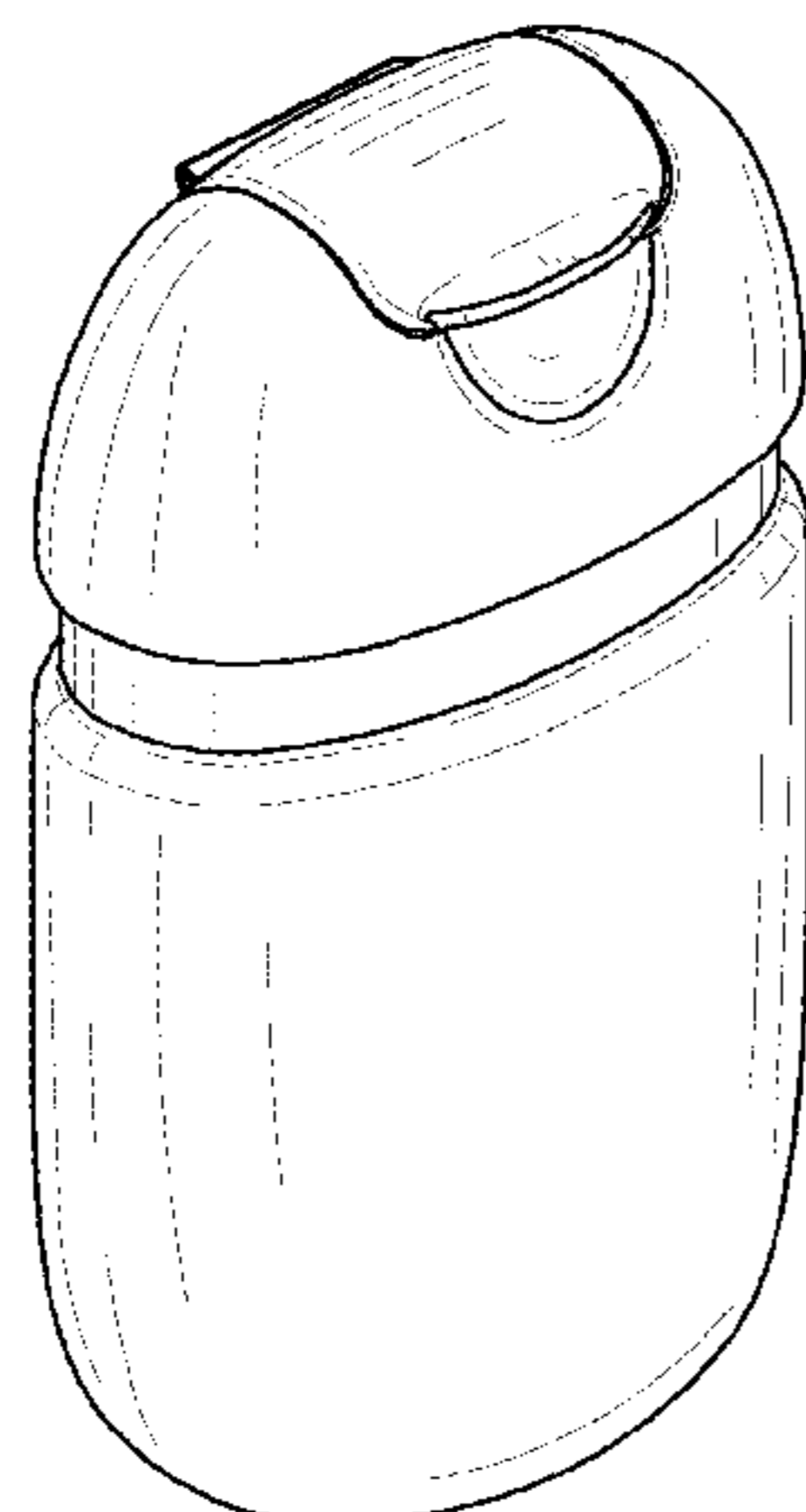

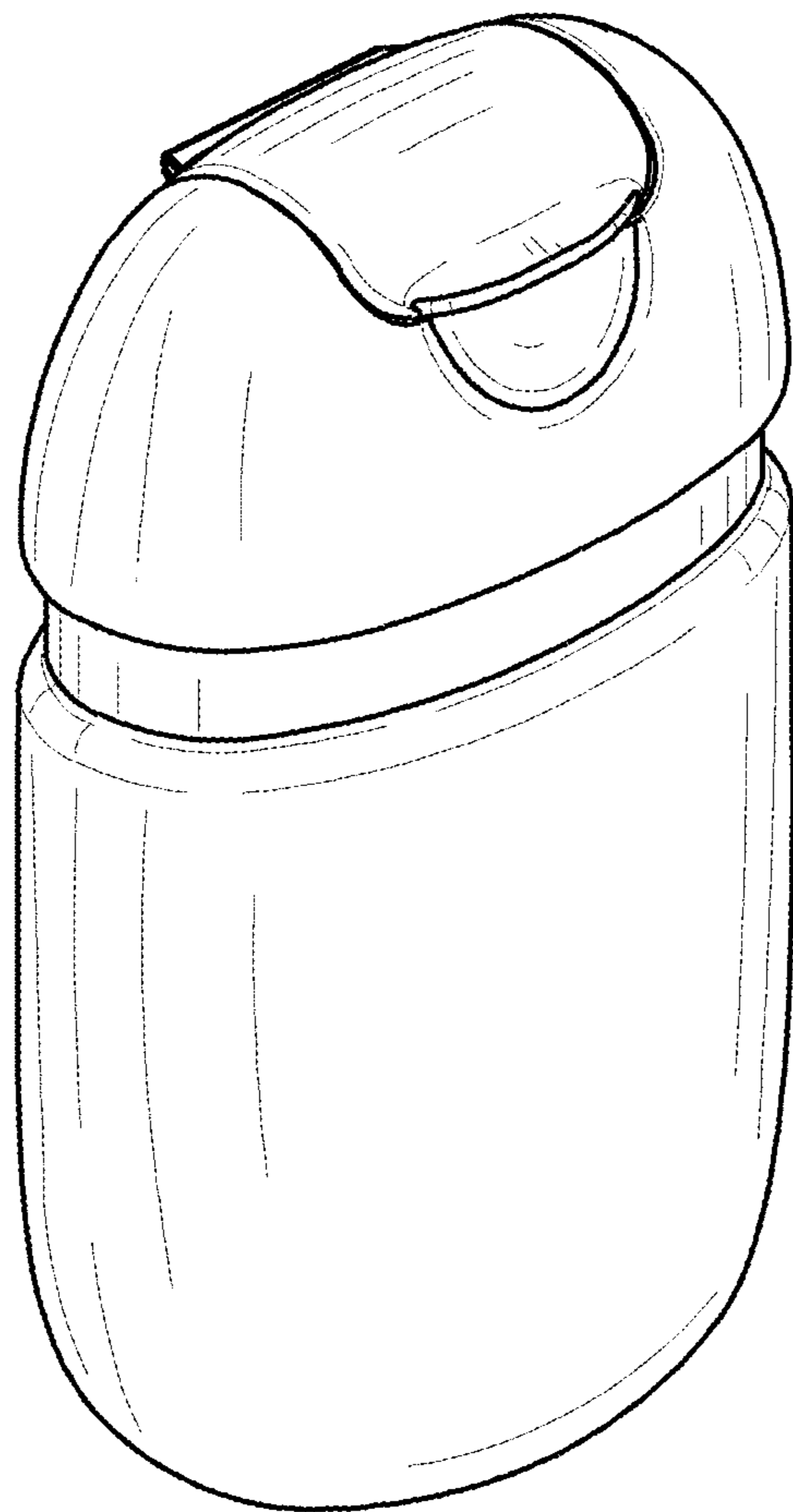

FIG. 1

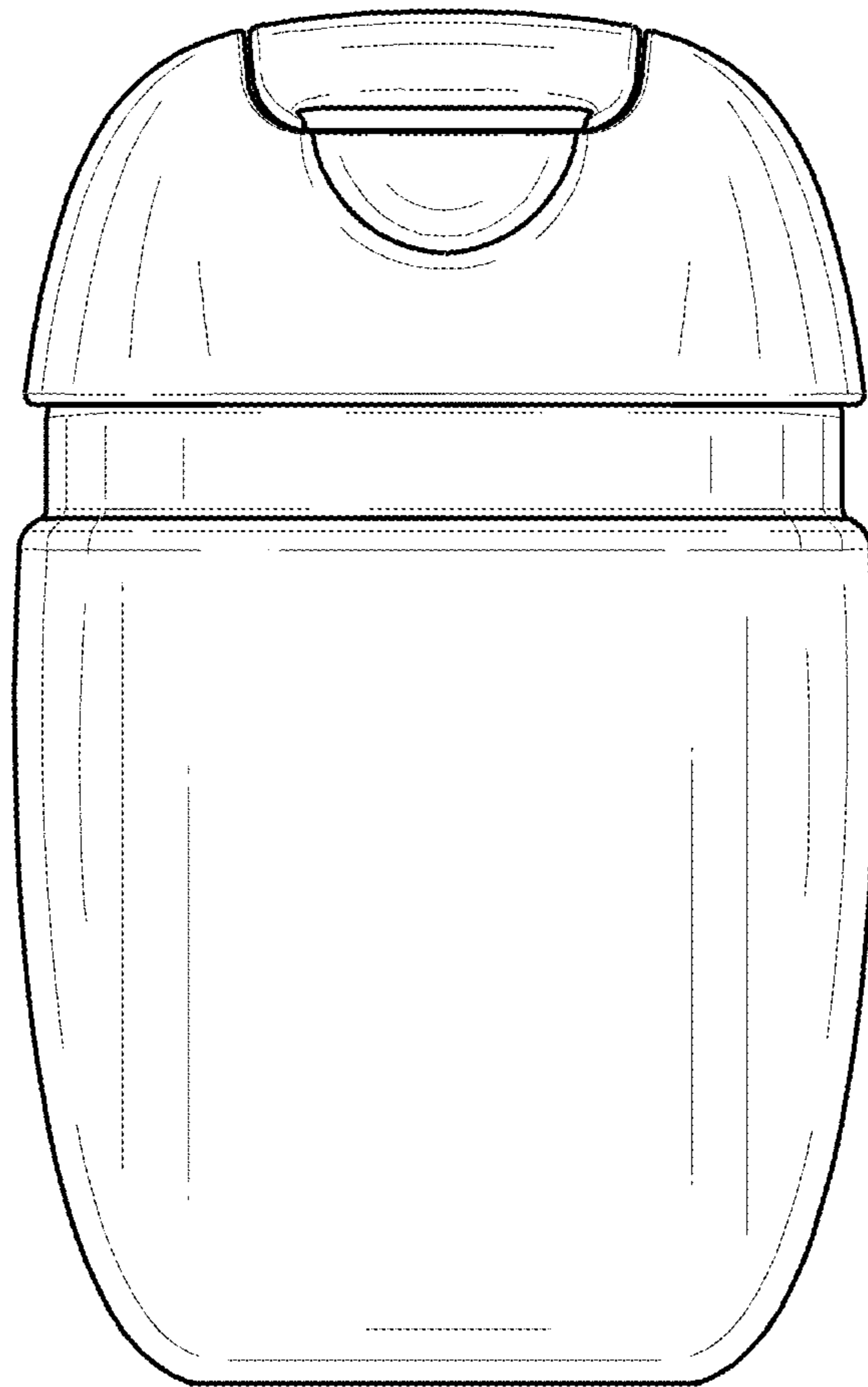

FIG. 2

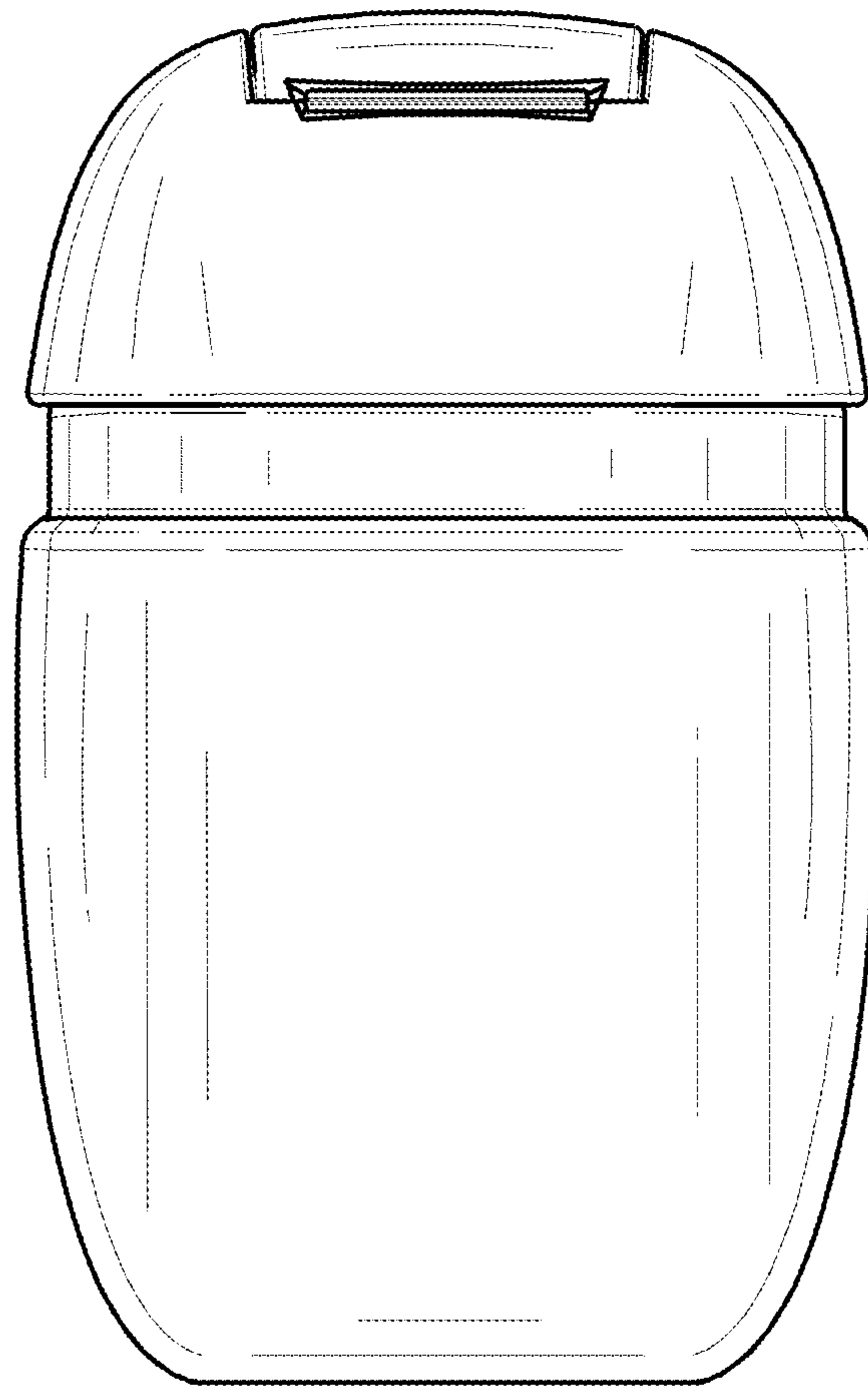

FIG. 3

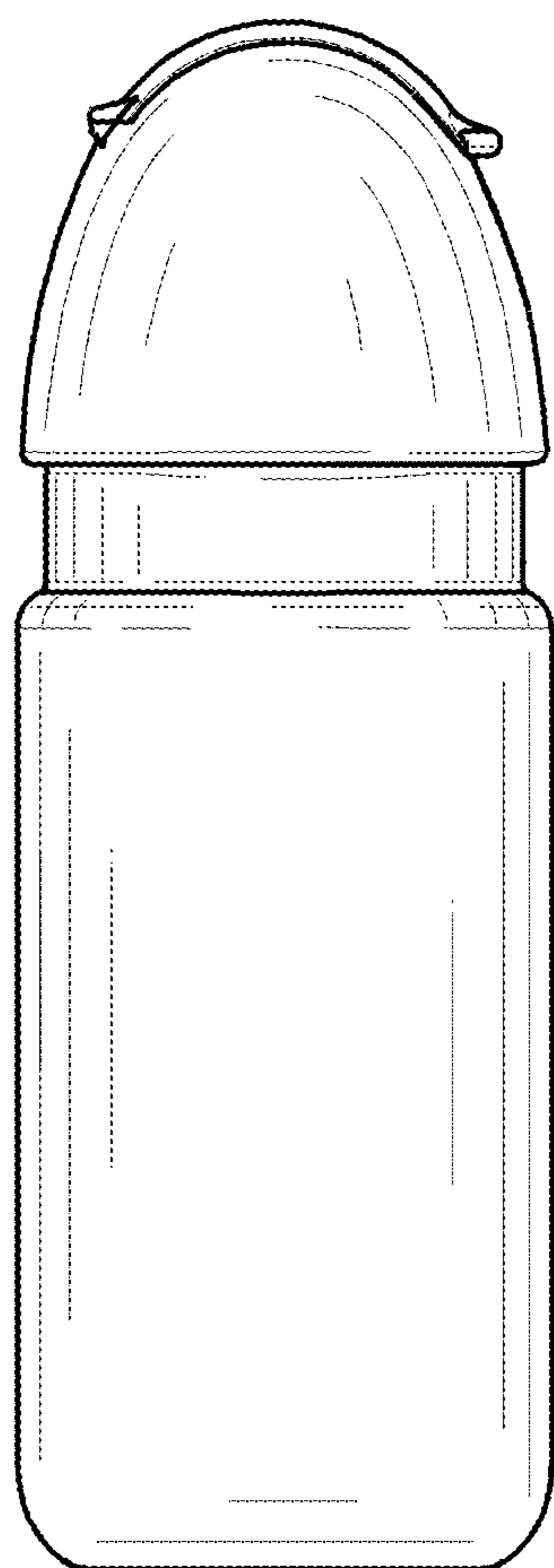

FIG. 4

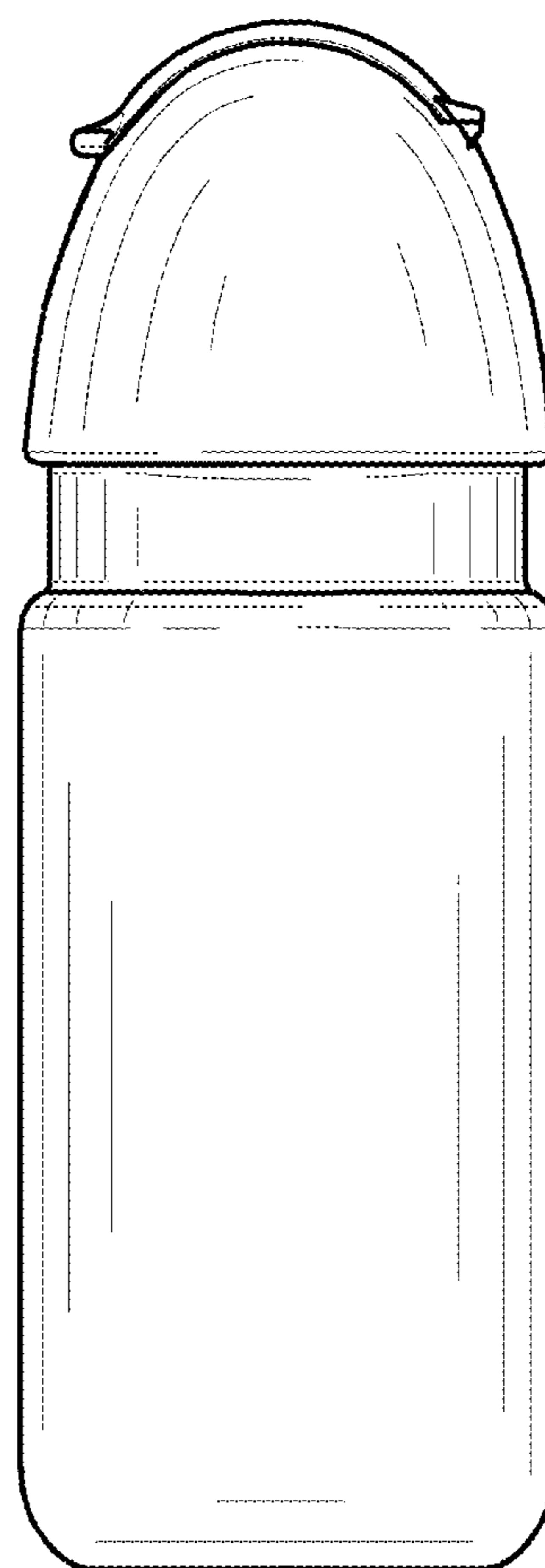

FIG. 5

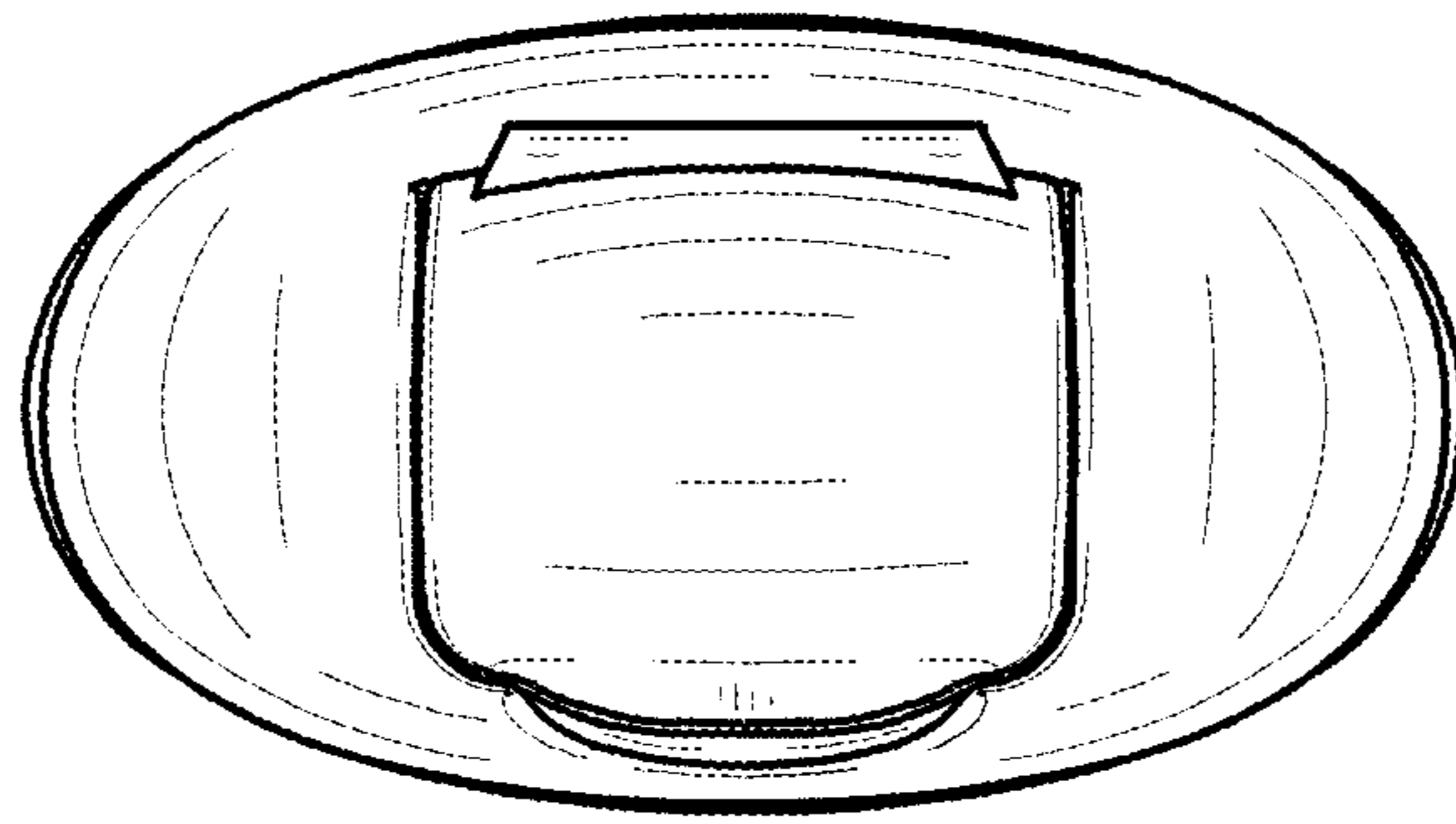

FIG. 6

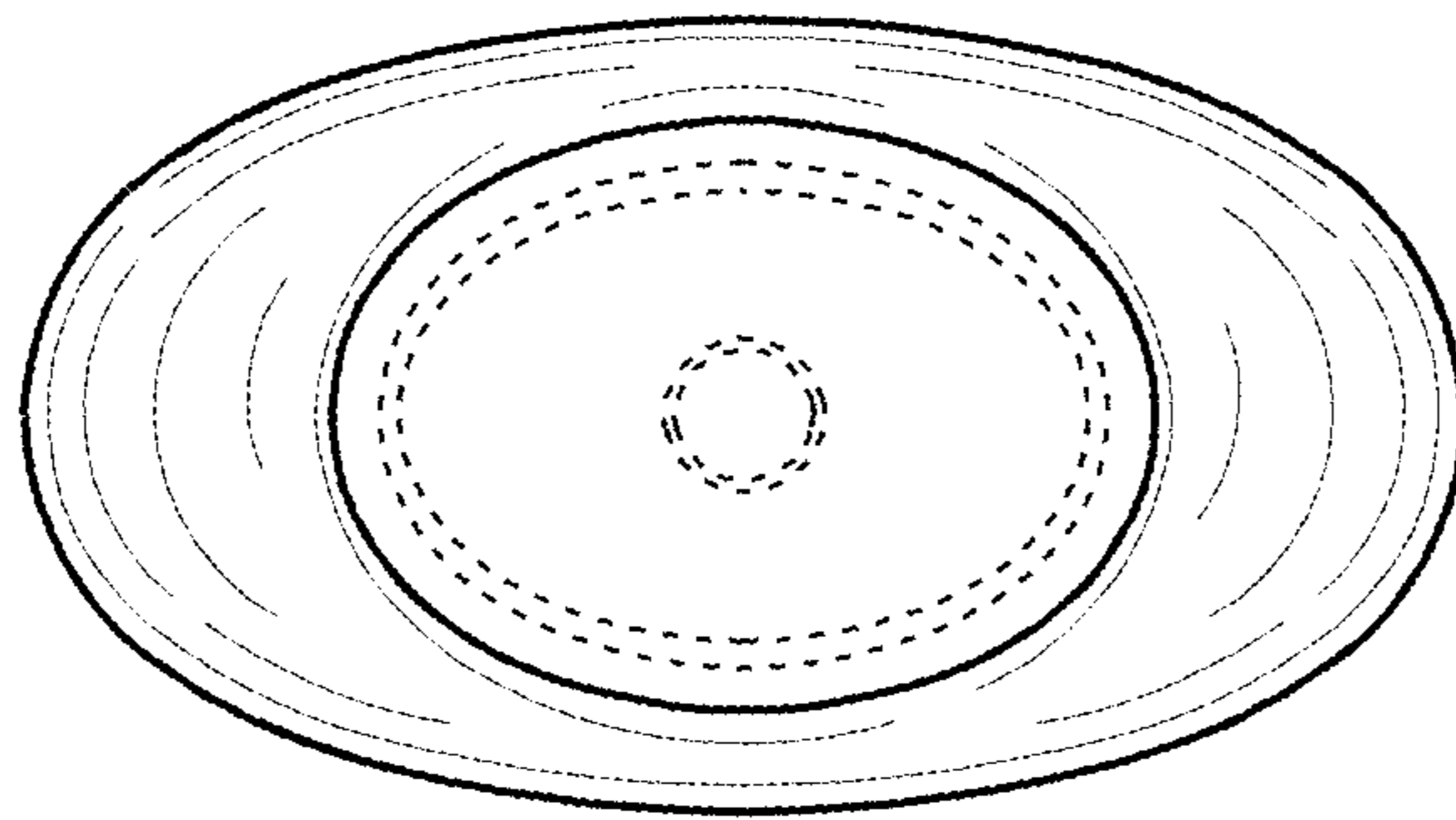

FIG. 7

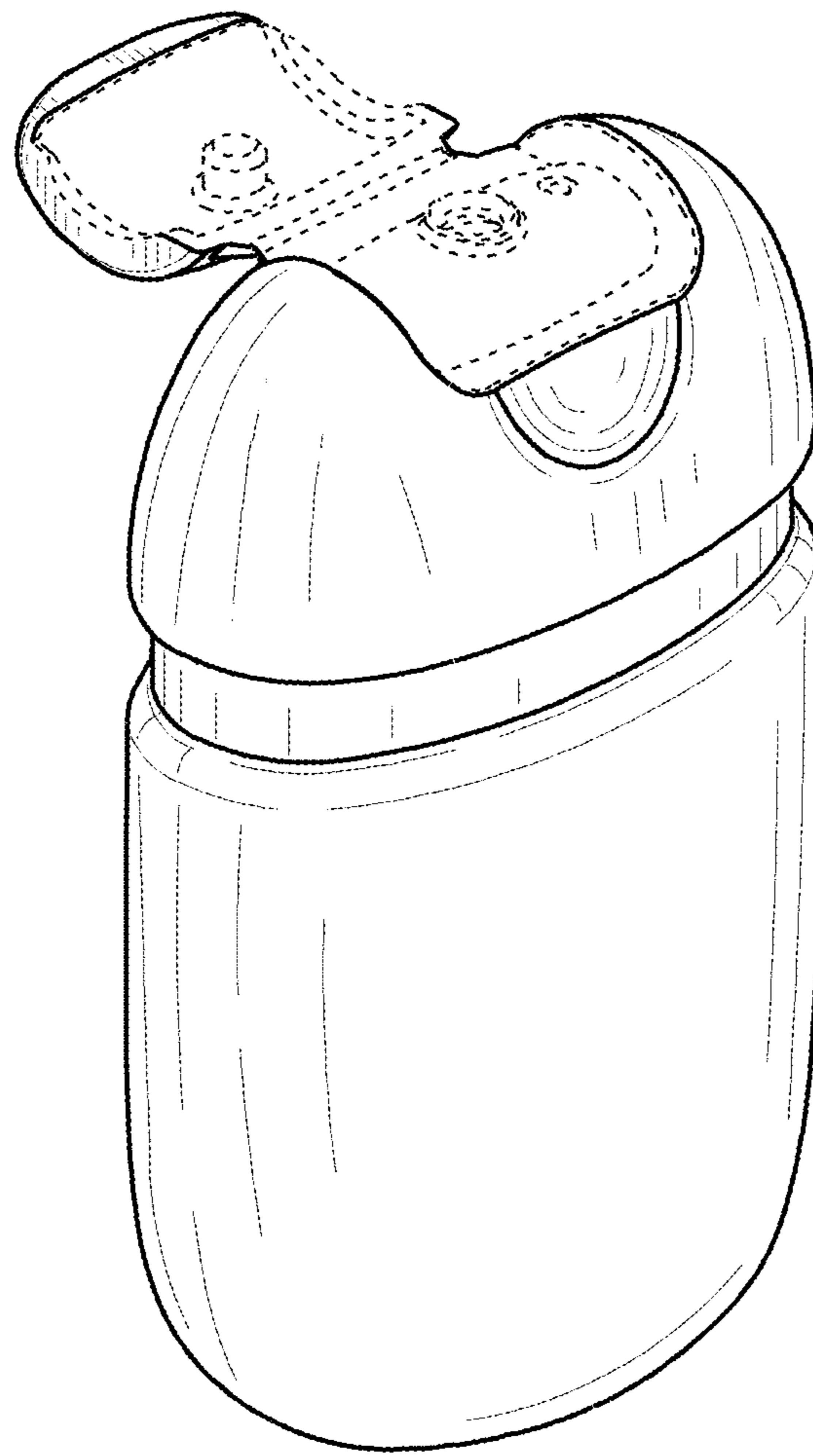

FIG. 8