



US00D752307S

(12) **United States Design Patent**
Wyse et al.

(10) **Patent No.:** **US D752,307 S**
(45) **Date of Patent:** **** Mar. 22, 2016**

(54) **POWERED WAGON**
(71) Applicant: **Granite Industries, Inc.**, Archbold, OH
(US)
(72) Inventors: **Steven J. Wyse**, Archbold, OH (US);
Brent A. Johnston, West Unity, OH
(US)
(73) Assignee: **Granite Industries, Inc.**, Archbold, OH
(US)

(**) Term: **14 Years**

(21) Appl. No.: **29/510,168**

(22) Filed: **Nov. 25, 2014**

(51) **LOC (10) Cl.** **12-02**

(52) **U.S. Cl.**
USPC **D34/16; D34/12**

(58) **Field of Classification Search**
USPC D34/12-27; 280/653, 33.997, 33.992,
280/33.991, 33.993, 47.18, 47.26, 47.34,
280/47.31, 47.15, 47.12, 47.131, 47.17
CPC B62B 1/18; B62B 1/20; B62B 1/208;
B62B 1/002; B62B 1/10; B62B 1/14; B62B
1/204; B62B 1/22; B62B 1/00; B62B 1/16;
B62B 1/206; B62B 5/00; B62B 5/067; B62B
5/068; B62B 5/0083; B62B 5/062; B62B
5/006

See application file for complete search history.

(56) **References Cited**

U.S. PATENT DOCUMENTS

2,800,335 A * 7/1957 Clapp B62B 1/208
280/42
3,045,847 A * 7/1962 Fisher B62B 1/18
280/47.31
3,690,692 A * 9/1972 Florian B62B 1/208
220/6
3,722,904 A * 3/1973 Puckett B62B 1/208
280/47.31

D244,438 S * 5/1977 Samuels D34/16
D285,322 S * 8/1986 Appel D21/425
4,802,681 A * 2/1989 Hung B62B 1/002
280/47.18
5,350,030 A * 9/1994 Mawhinney B62B 1/24
180/19.3
D606,565 S * 12/2009 Hickenbottom D15/17
D608,517 S * 1/2010 Rowlands D34/16
D668,830 S * 10/2012 Cooper D34/16
D694,981 S * 12/2013 Albert D34/16
2012/0181762 A1 * 7/2012 Skijus B60N 3/026
280/47.31
2015/0158515 A1 * 6/2015 Tabrizi B62B 1/204
280/47.31

* cited by examiner

Primary Examiner — Cynthia Ramirez

(74) *Attorney, Agent, or Firm* — Hovey Williams LLP

(57) **CLAIM**

The ornamental design for a powered wagon, as shown and described.

DESCRIPTION

FIG. 1 is a front perspective view of a powered wagon embodying our design;
FIG. 2 is a rear perspective view of the powered wagon shown in FIG. 1;
FIG. 3 is a front elevational view of the powered wagon shown in FIGS. 1 and 2;
FIG. 4 is a left side elevational view of the powered wagon depicted in FIGS. 1-3;
FIG. 5 is a rear elevational view of the powered wagon depicted in FIGS. 1-4;
FIG. 6 is a right side elevational view of the powered wagon depicted in FIGS. 1-5; and,
FIG. 7 is a top plan view of the powered wagon shown in FIGS. 1-6.

The broken lines shown in the figures are included for the purpose of illustrating environment and form no part of the claimed design.

1 Claim, 7 Drawing Sheets

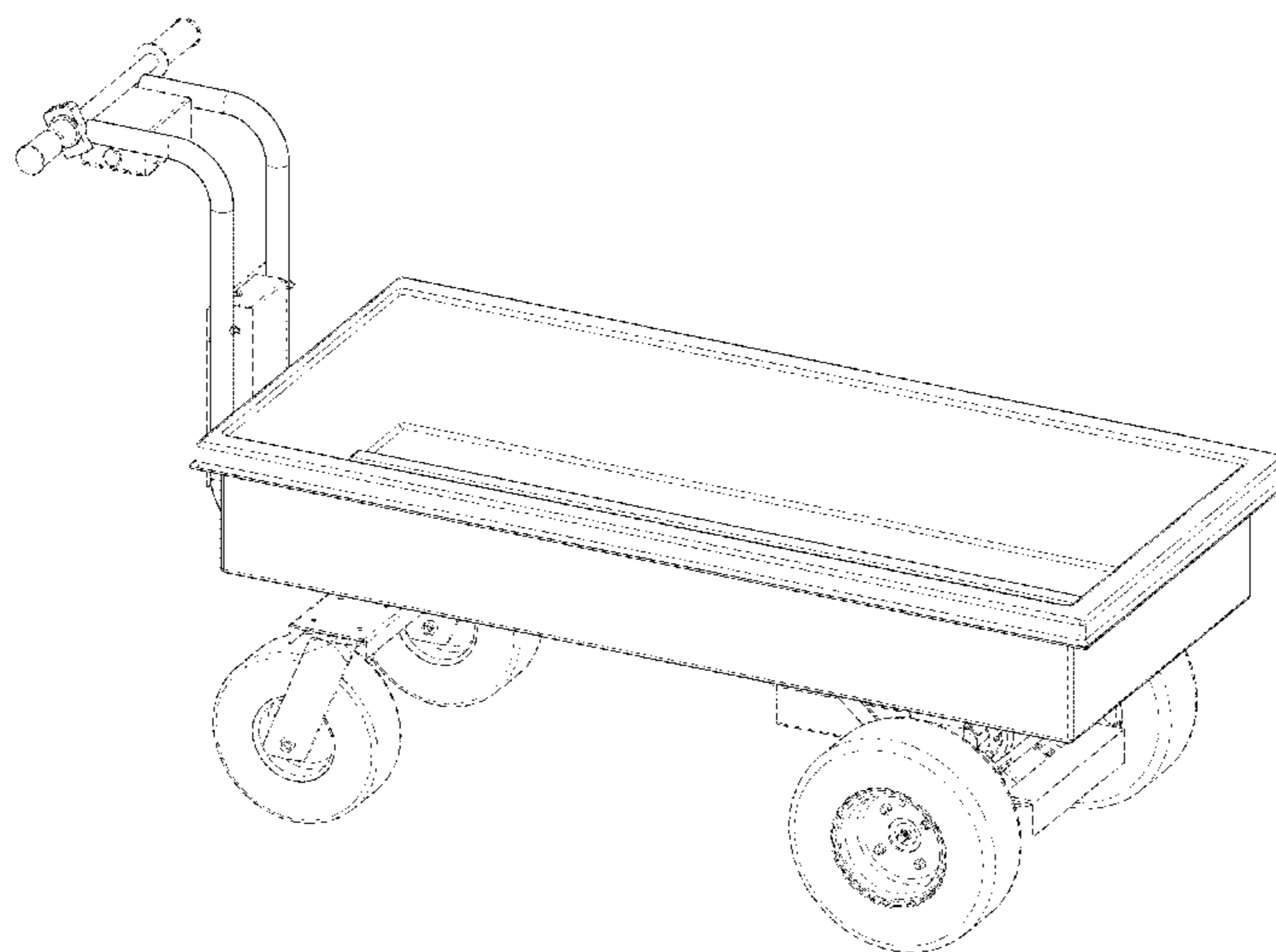

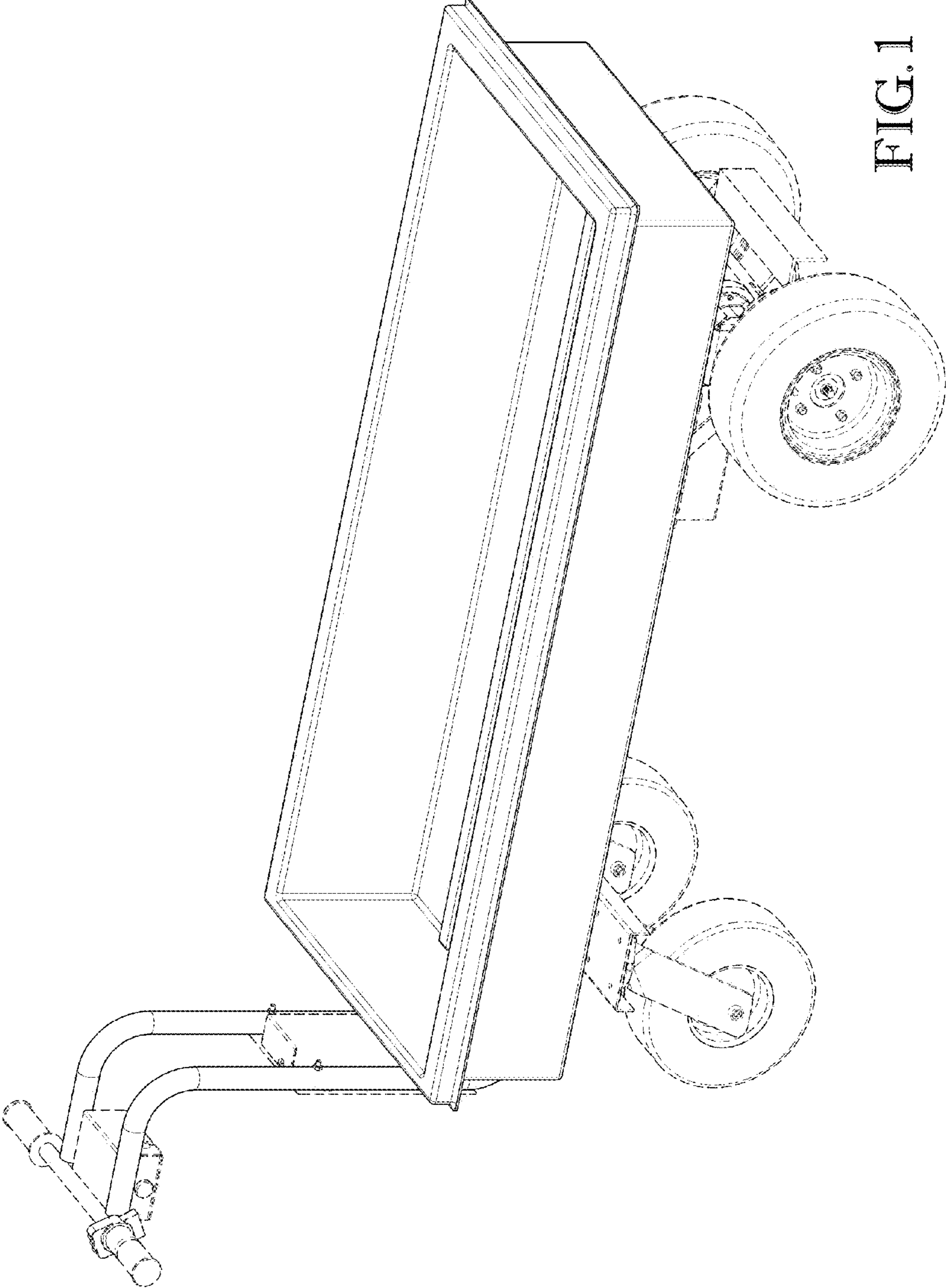

FIG. 1

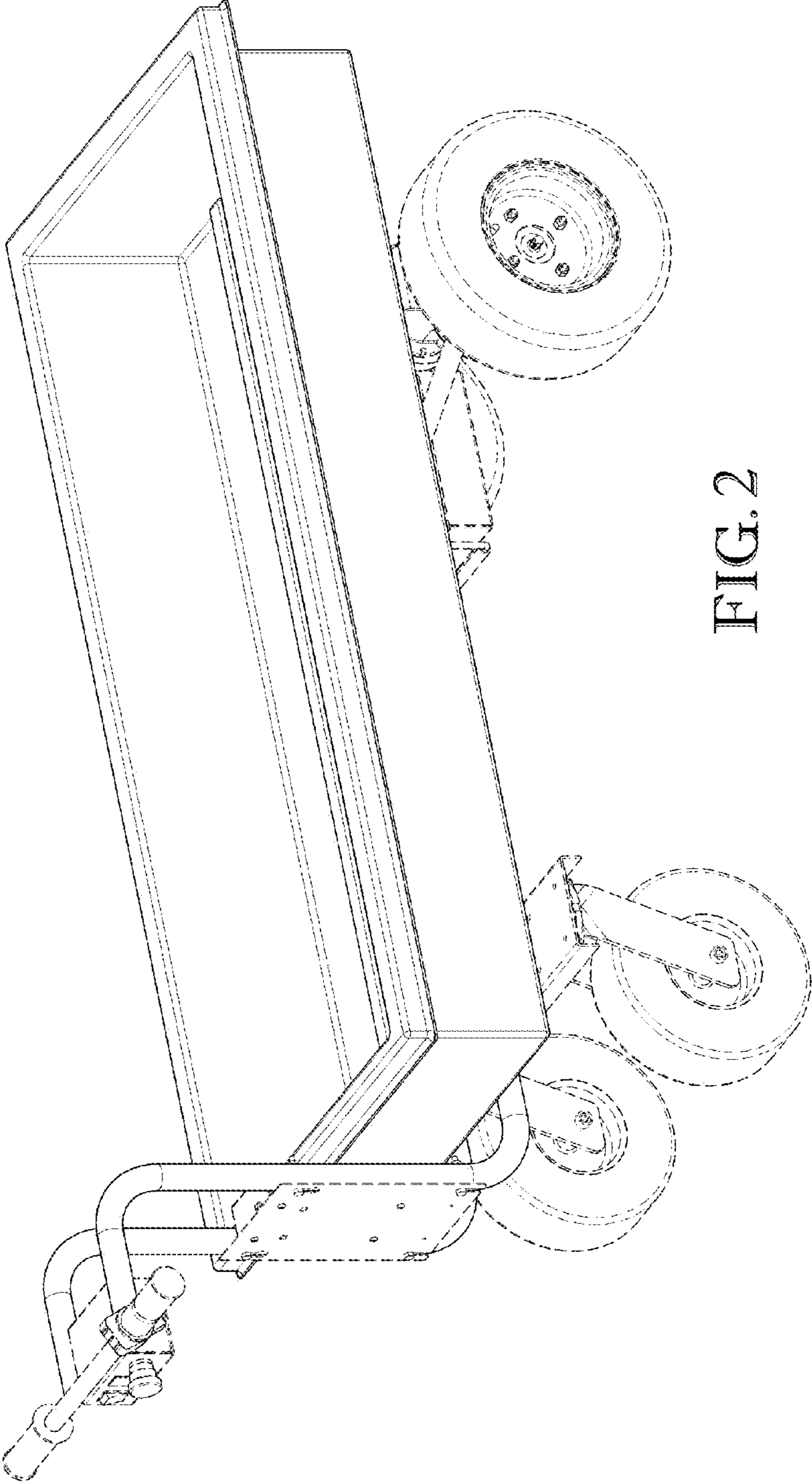

FIG. 2

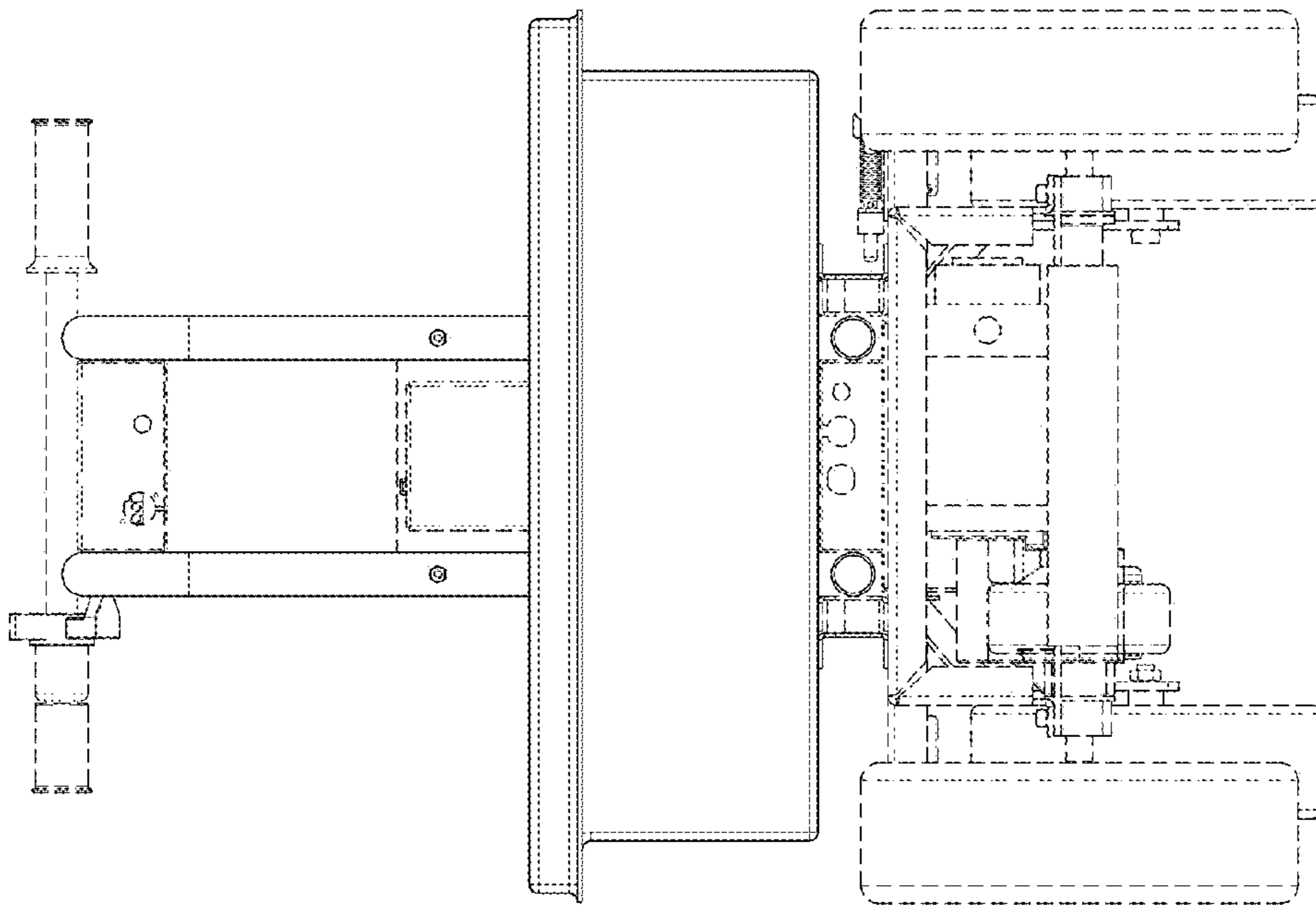

FIG. 3

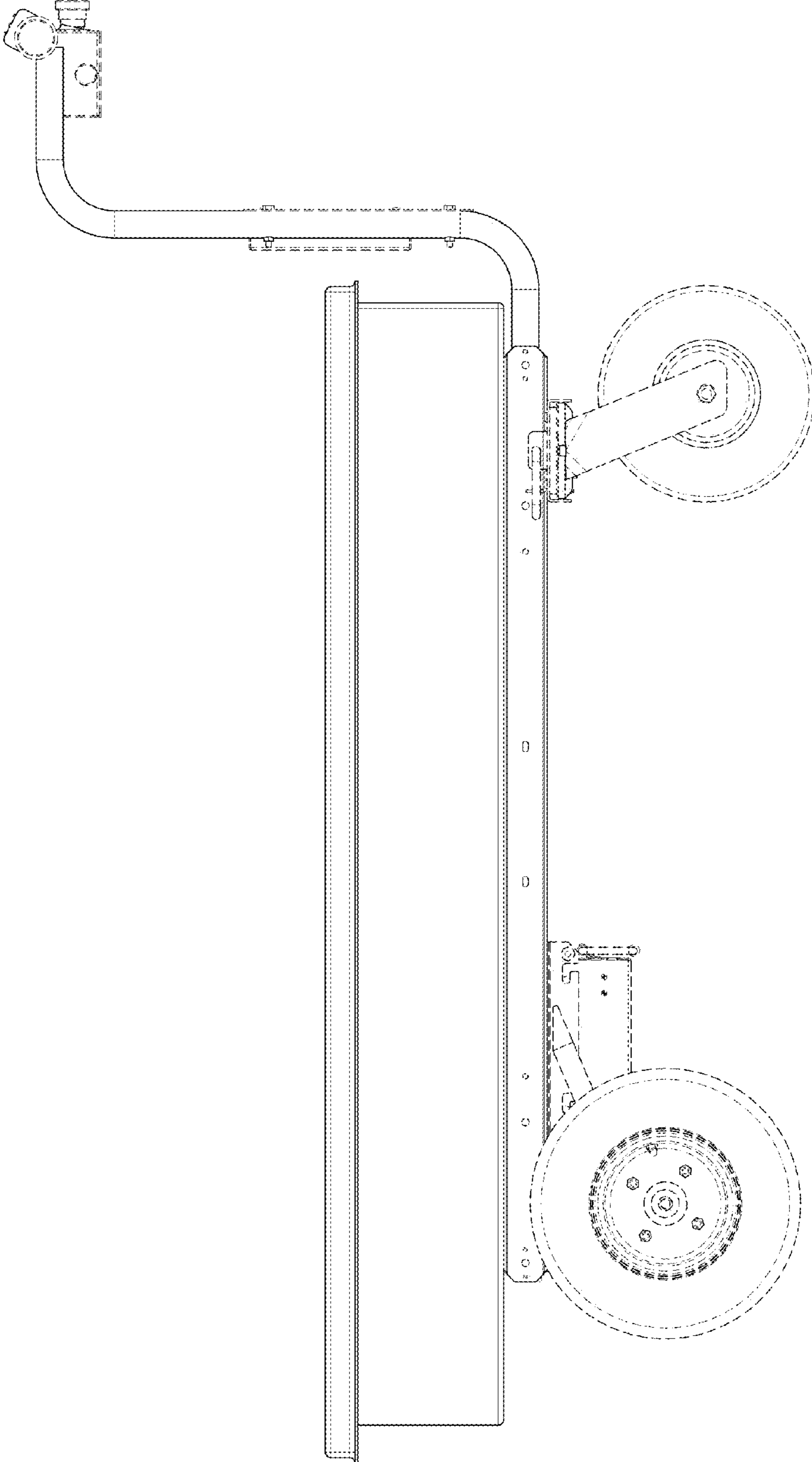

FIG. 4

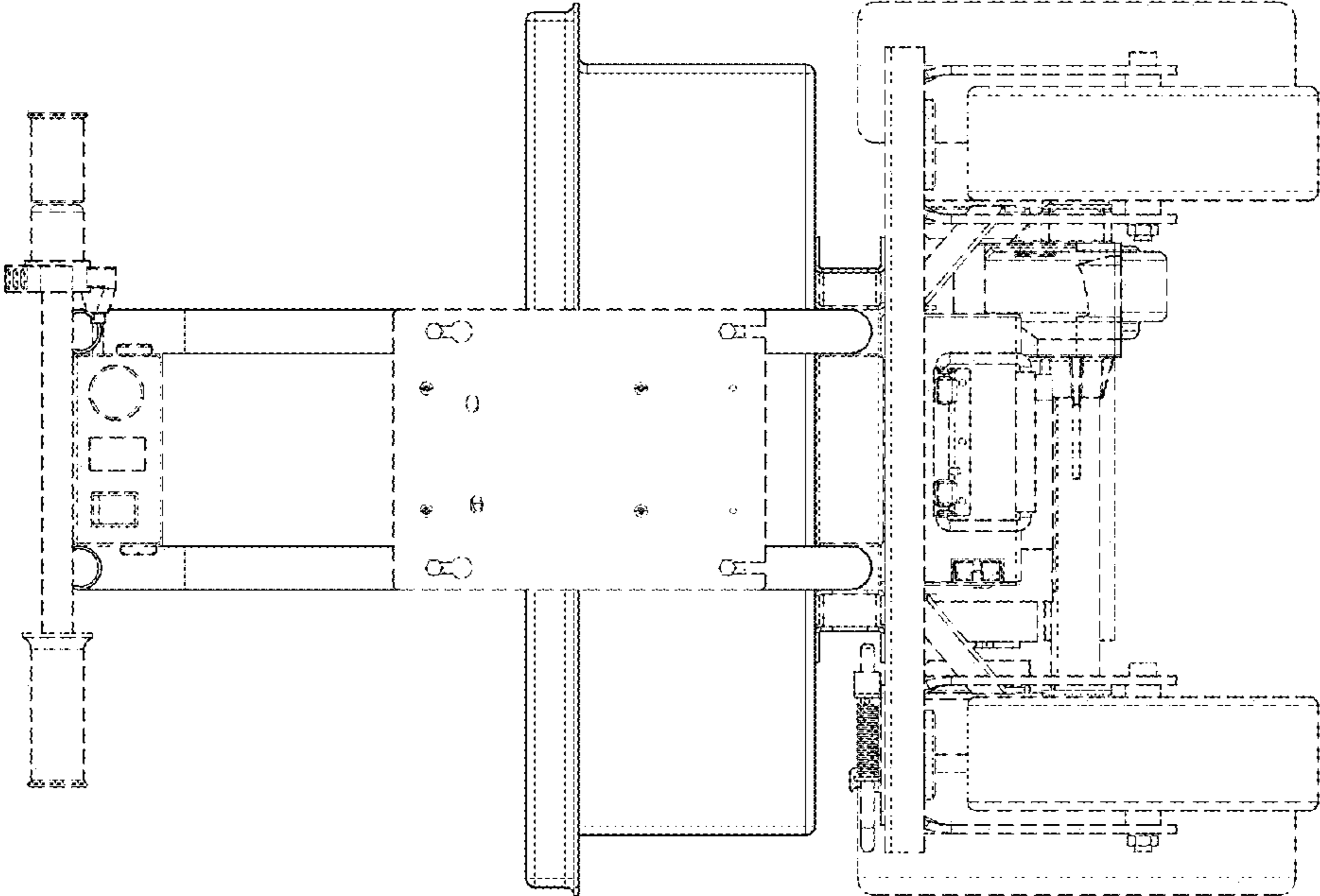

FIG. 5

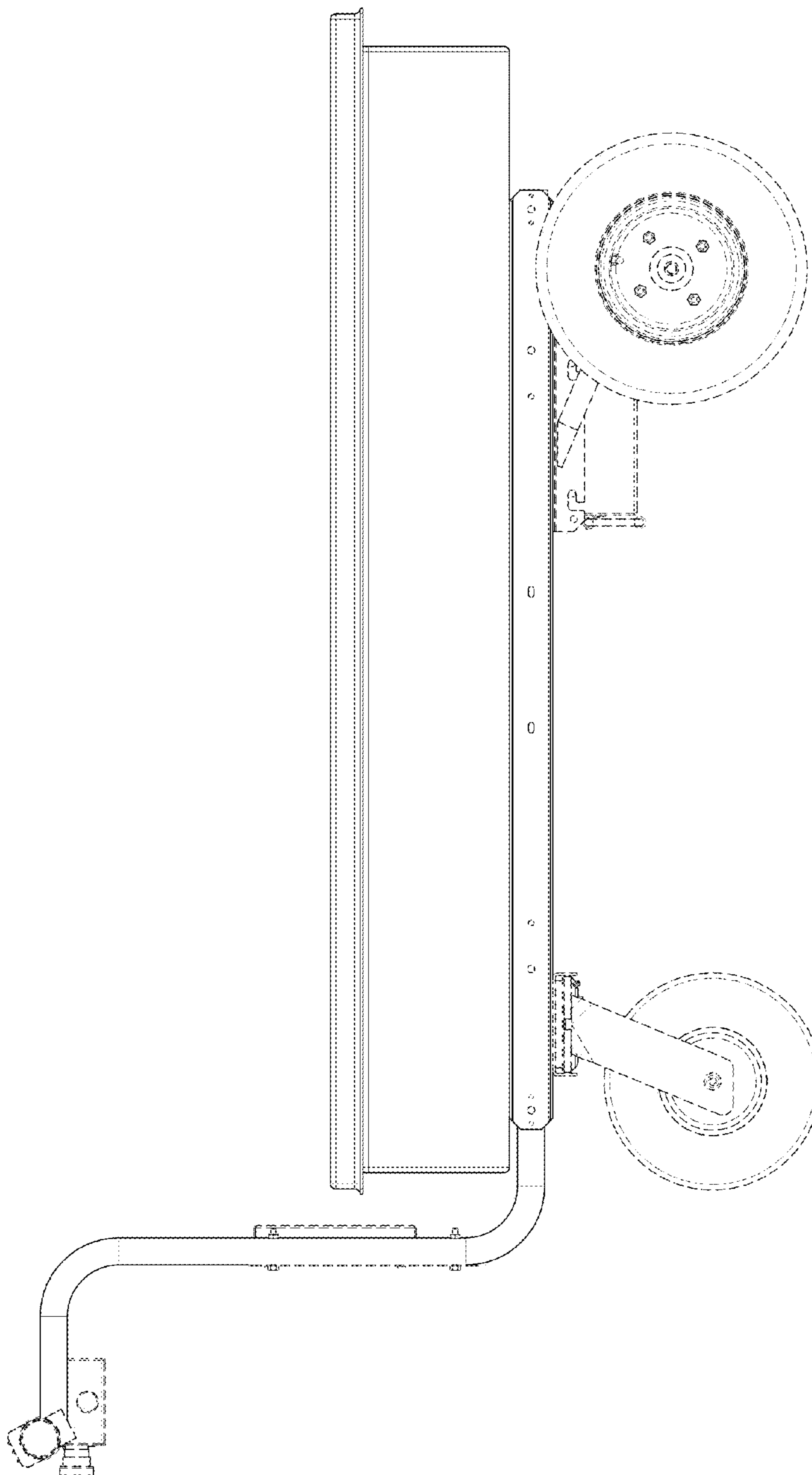

FIG. 6

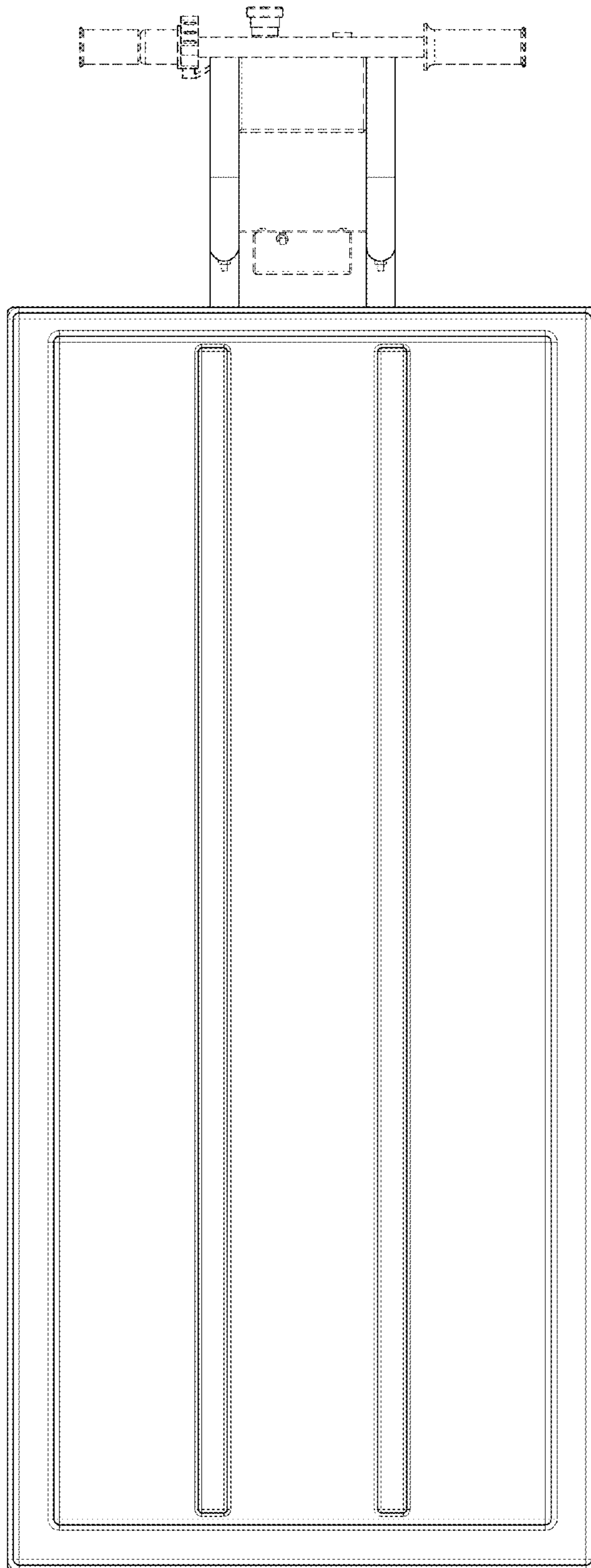

FIG. 7