



US00D751843S

(12) **United States Design Patent**
Clark et al.

(10) **Patent No.:** **US D751,843 S**
(45) **Date of Patent:** **** Mar. 22, 2016**

(54) **RETAIL DISPLAY FIXTURE**

6,520,355 B1 2/2003 Pritchard et al.
6,659,294 B1 12/2003 Simard
D537,274 S 2/2007 Pirro et al.

(71) Applicant: **TARGET BRANDS, INC.**,
Minneapolis, MN (US)

(Continued)

(72) Inventors: **Jeremy A. Clark**, Minneapolis, MN
(US); **Michael A. Whittier**,
Minneapolis, MN (US); **David Joseph**
Floersch, Brooklyn Park, MN (US);
David Cheney, New Brighton, MN (US)

OTHER PUBLICATIONS

U.S. Appl. No. 62/111,893, filed Feb. 4, 2015 (36 pages).

Primary Examiner — Kelley Donnelly

(74) *Attorney, Agent, or Firm* — Griffiths & Seaton PLLC;
Joann M. Seaton

(73) Assignee: **TARGET BRANDS, INC.**,
Minneapolis, MN (US)

(57) **CLAIM**

(**) Term: **14 Years**

The ornamental design for a retail display fixture, as shown
and described.

(21) Appl. No.: **29/516,633**

DESCRIPTION

(22) Filed: **Feb. 4, 2015**

(51) **LOC (10) Cl.** **06-06**

(52) **U.S. Cl.**
USPC **D6/675**

(58) **Field of Classification Search**
USPC D6/552, 670, 672, 675, 682.2, 683,
D6/708; D13/184; D16/215
CPC A47F 1/00; A47F 5/025; A47F 9/00
See application file for complete search history.

FIG. 1 is a front perspective view of a retail display fixture
showing our new design;
FIG. 2 is a front view thereof;
FIG. 3 is a rear view thereof;
FIG. 4 is a right side view thereof;
FIG. 5 is a left side view thereof;
FIG. 6 is a top view thereof; and
FIG. 7 is a bottom view thereof.
FIG. 8 is a front perspective view of a retail display fixture
shown with environment thereof;
FIG. 9 is a front view thereof;
FIG. 10 is a rear view thereof;
FIG. 11 is a right side view thereof;
FIG. 12 is a left side view thereof;
FIG. 13 is a top view thereof; and,
FIG. 14 is a bottom view thereof.

(56) **References Cited**

U.S. PATENT DOCUMENTS

2,710,241 A	6/1957	Lieberman
3,297,374 A	1/1967	Radek
3,302,797 A	2/1967	Kolster
3,334,952 A	8/1967	Brach
3,394,973 A	7/1968	Scott
3,677,614 A	7/1972	Radek
3,992,068 A	11/1976	Galton
4,627,542 A	12/1986	Fredrickson
D406,707 S	3/1999	Battaglia
5,918,750 A	7/1999	Jackson
5,947,307 A	9/1999	Battaglia et al.
D419,338 S	1/2000	Battaglia
6,467,856 B1	10/2002	Chang et al.

The features shown in broken lines are portions of the retail
display fixture or environmental subject matter to the retail
display fixture forming no part of the claimed design. The
features shown in long dash-short dash bolded broken lines
indicate the bounds of the claimed design and otherwise form
no part of the claimed design.

1 Claim, 12 Drawing Sheets

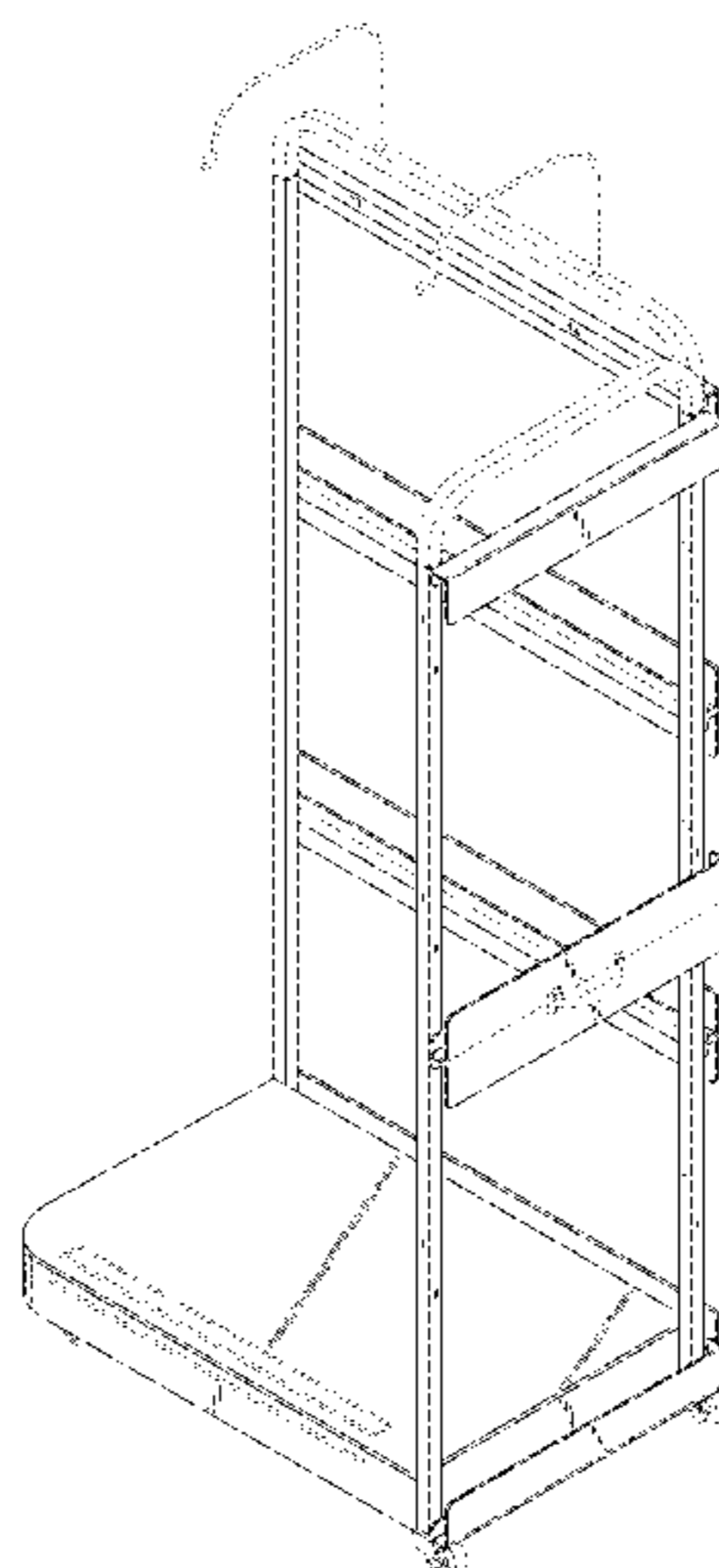

(56)

References Cited

U.S. PATENT DOCUMENTS

D576,426 S	9/2008	Yuen-Schat et al.	8,191,720 B2	6/2012	Clark et al.
D584,078 S	1/2009	Weigand	D681,978 S	5/2013	Pirro et al.
7,478,732 B2	1/2009	Brownfield et al.	D684,396 S	6/2013	Stukenberg et al.
D602,713 S	10/2009	Stukenberg	8,646,618 B2	2/2014	Peota et al.
D608,115 S	1/2010	Trinh et al.	8,733,563 B2	5/2014	Fadrowski
7,810,658 B2	10/2010	Clark et al.	8,752,718 B2	6/2014	Stukenberg et al.
7,988,000 B2	8/2011	Clark et al.	8,789,899 B2	7/2014	Pirro et al.
			8,807,356 B2	8/2014	Weigand et al.
			8,919,579 B2	12/2014	Weigand et al.
			2014/0230295 A1	8/2014	Hawkins

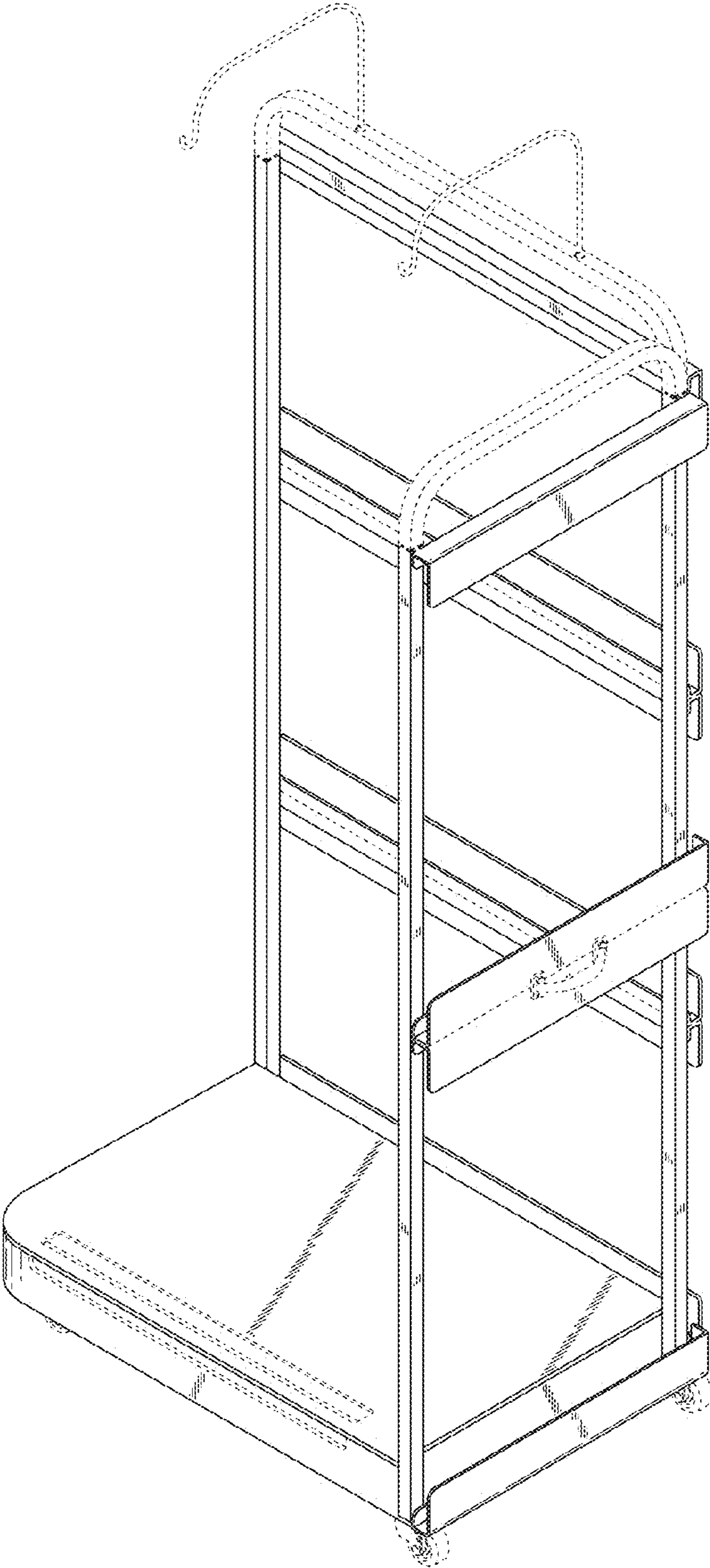

FIG. 1

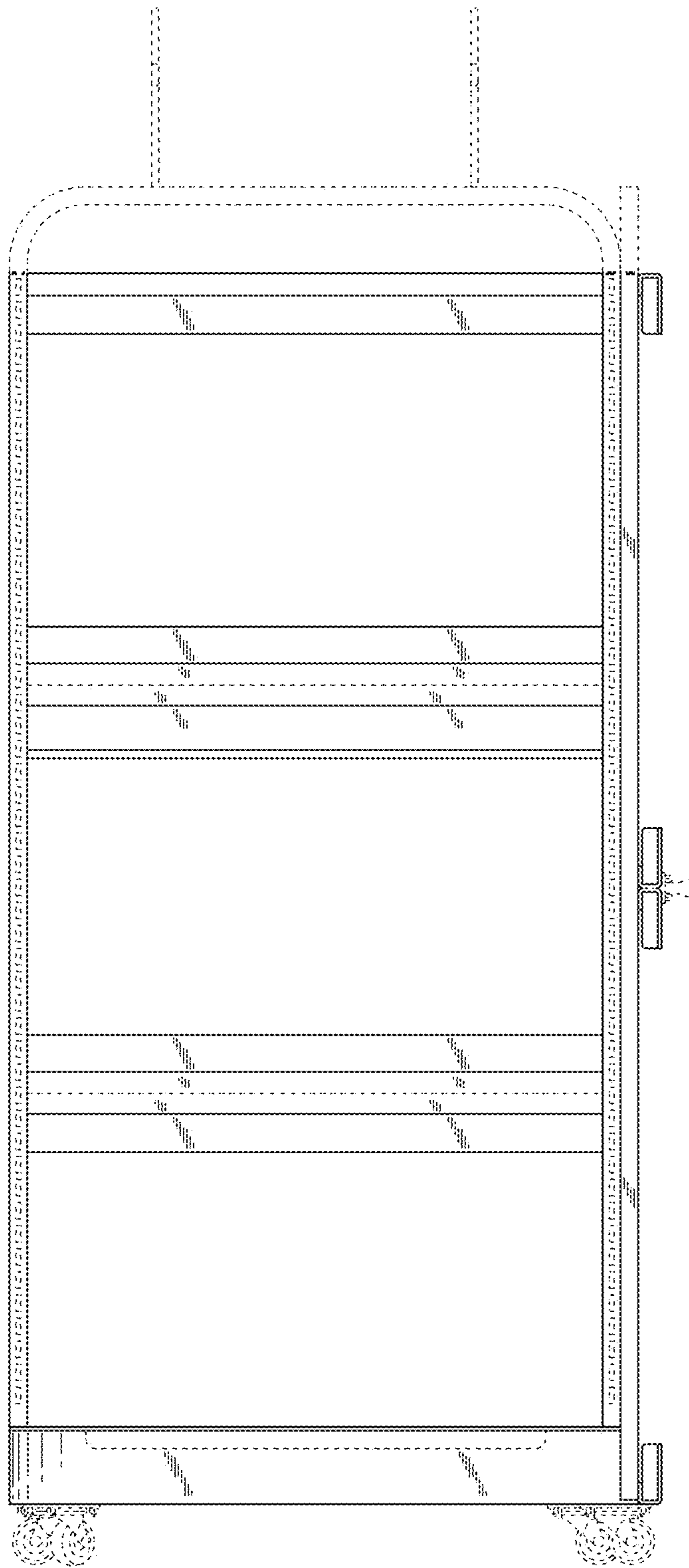

FIG. 2

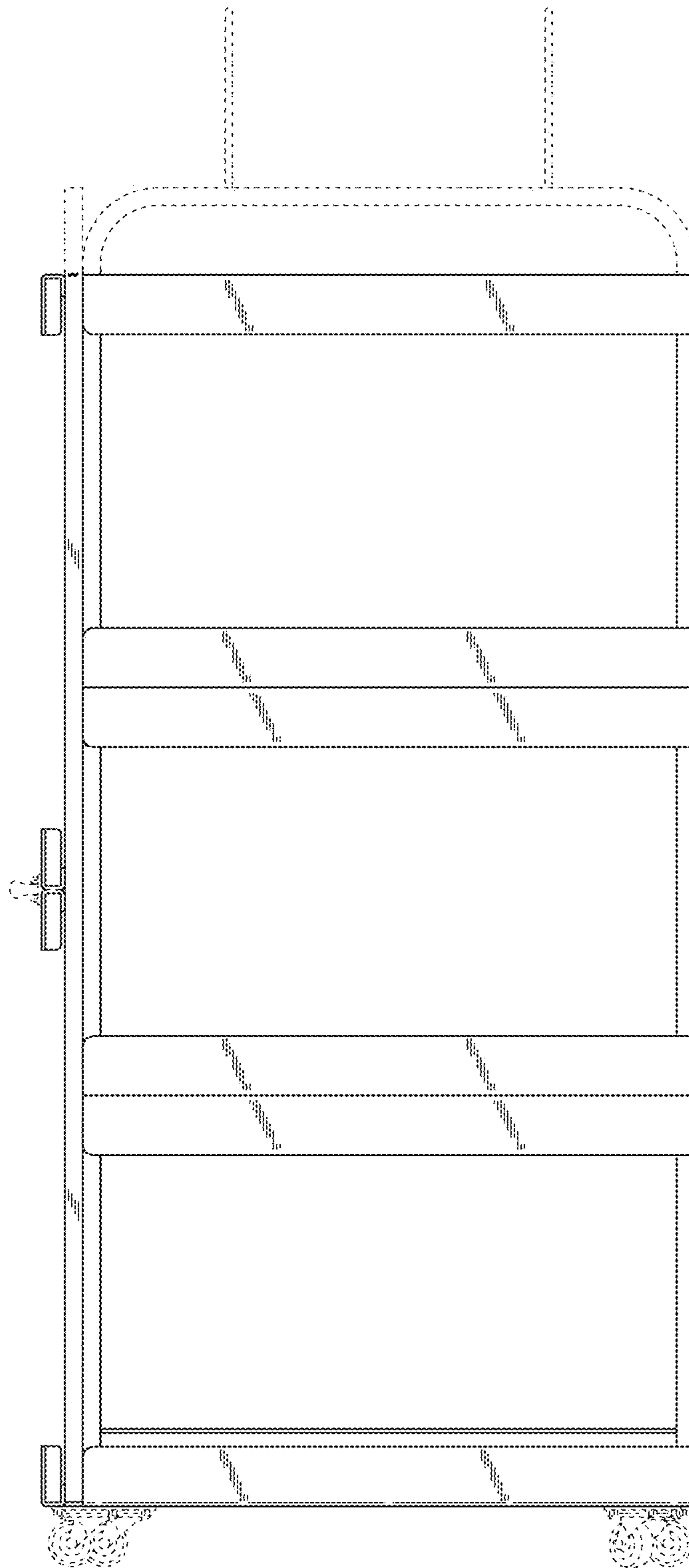

FIG. 3

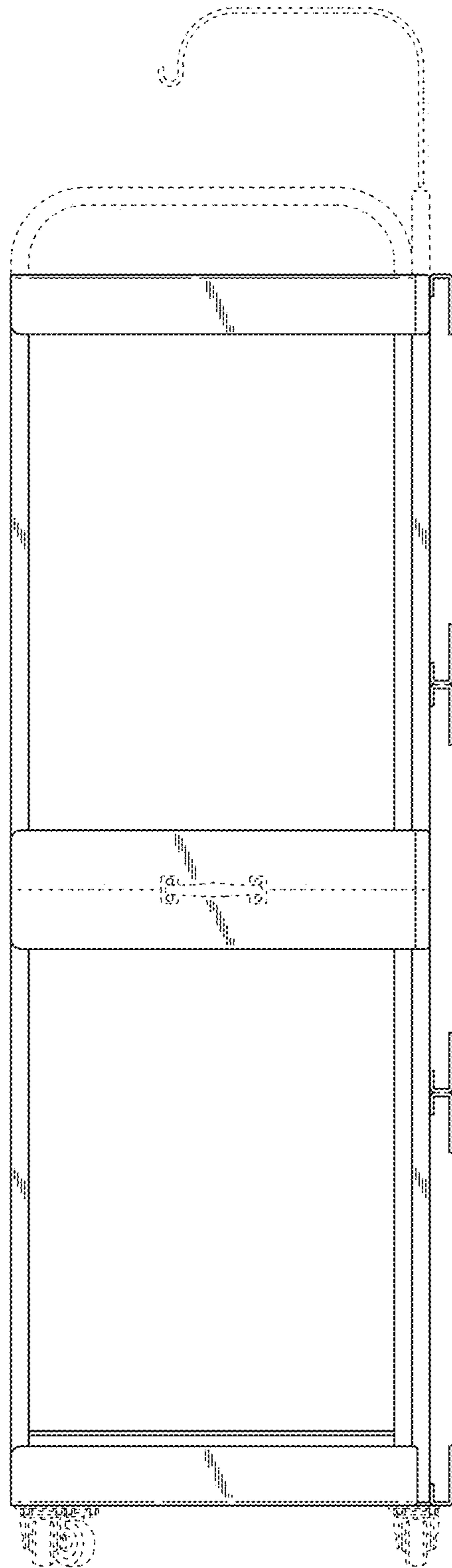

FIG. 4

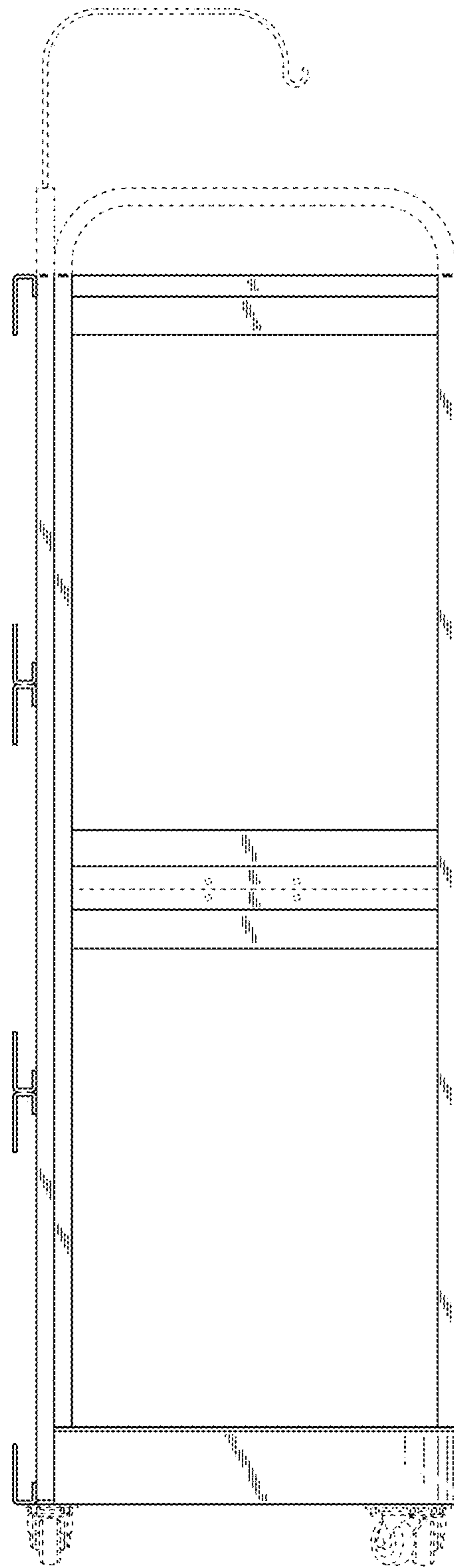

FIG. 5

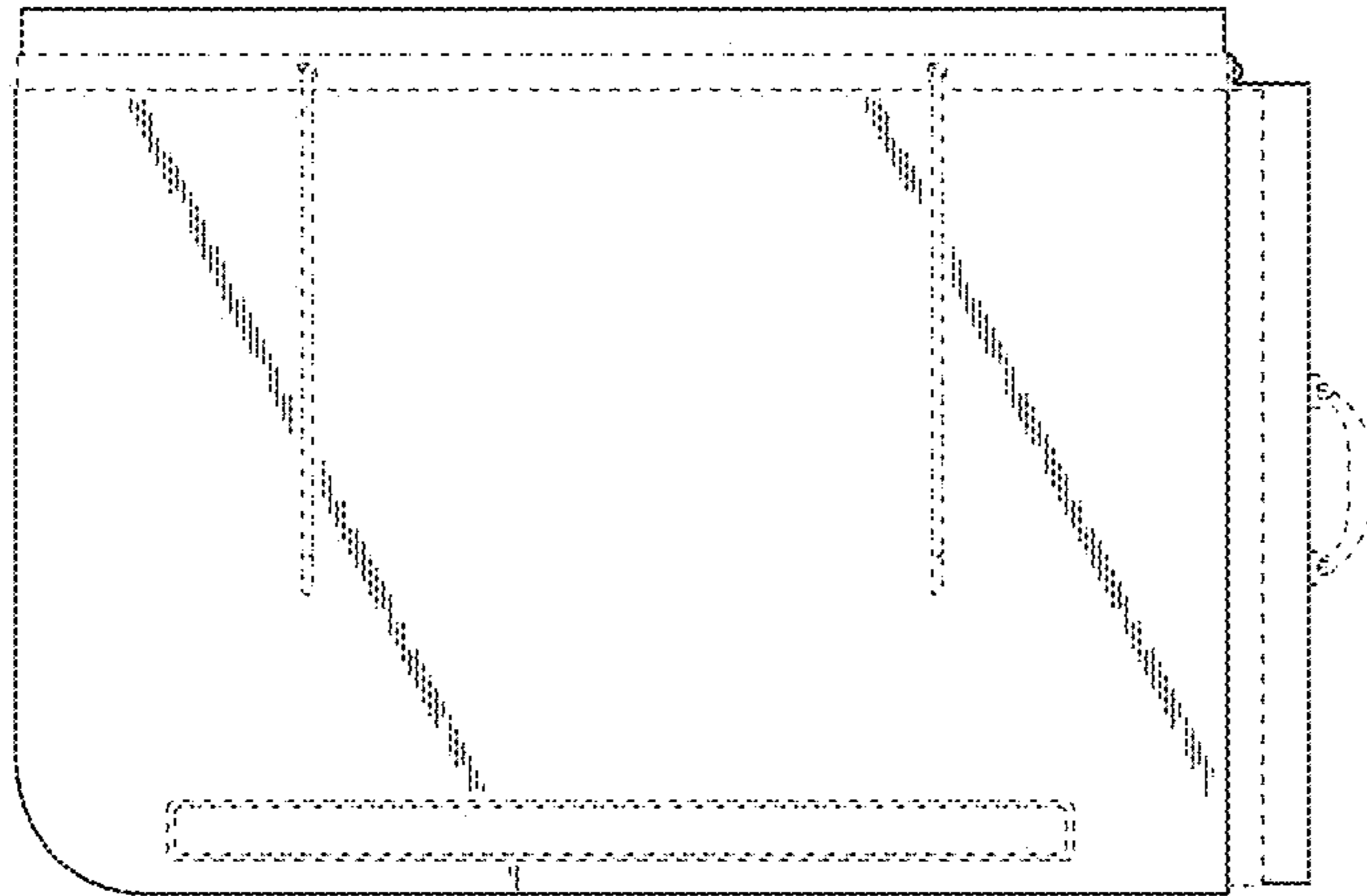

FIG. 6

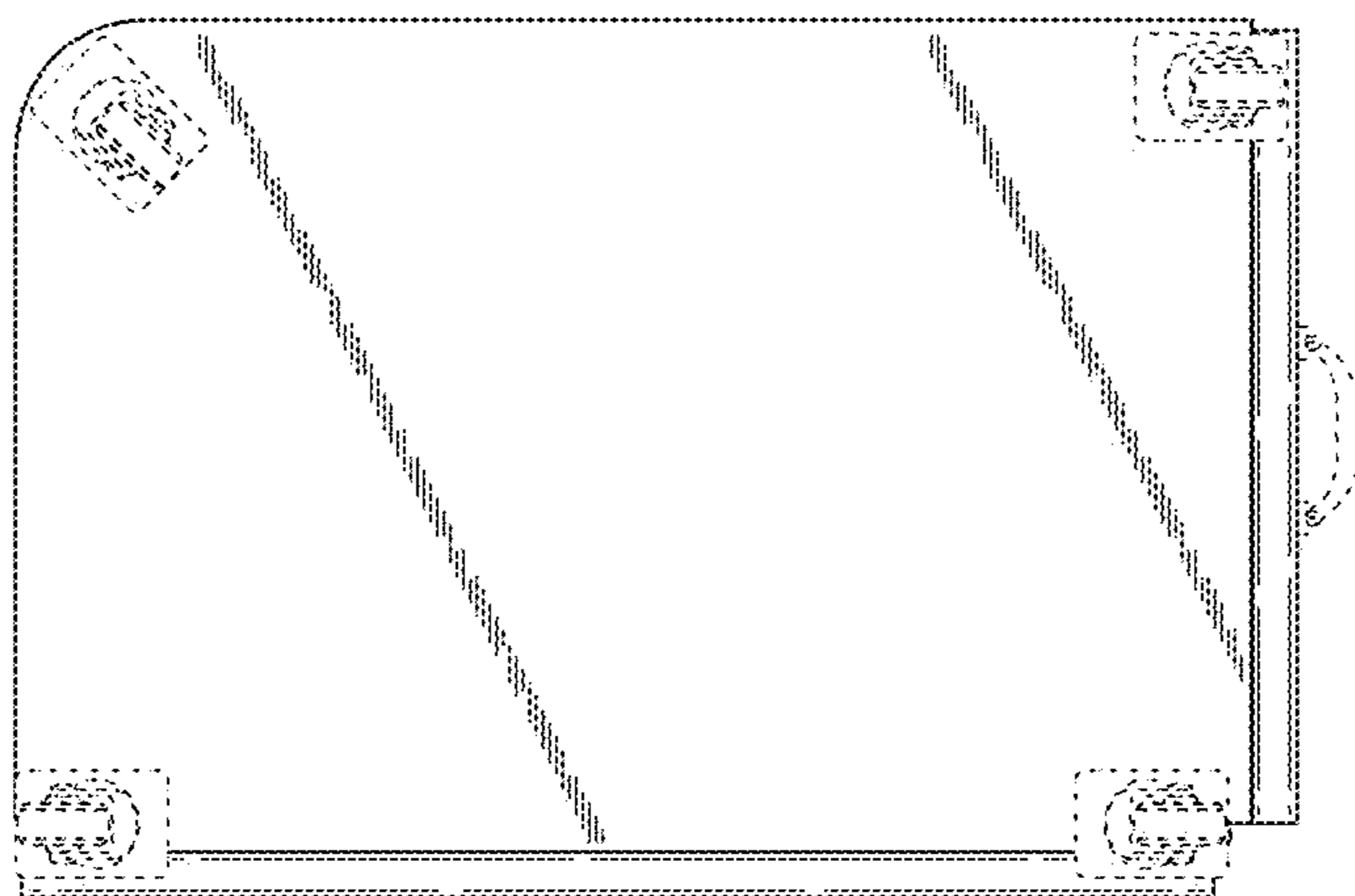

FIG. 7

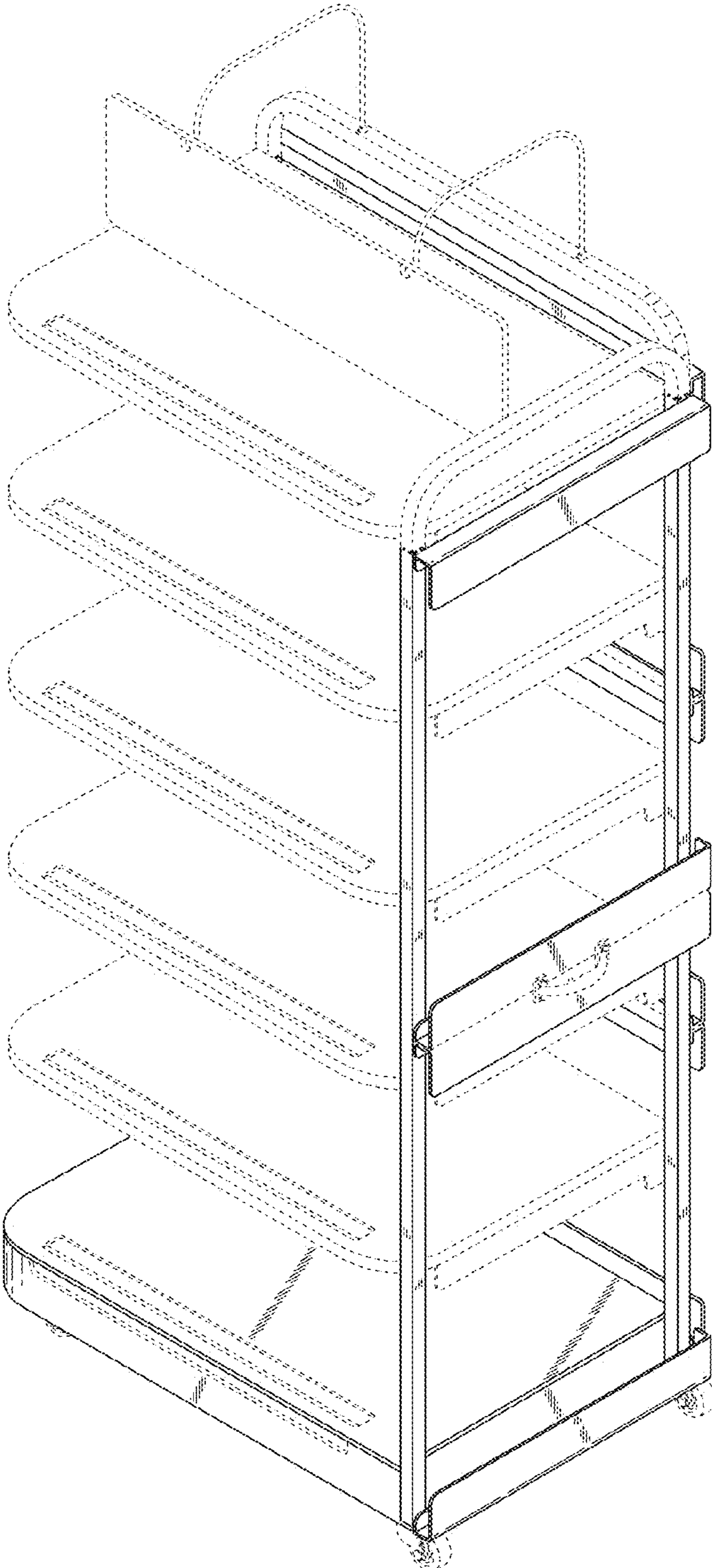

FIG. 8

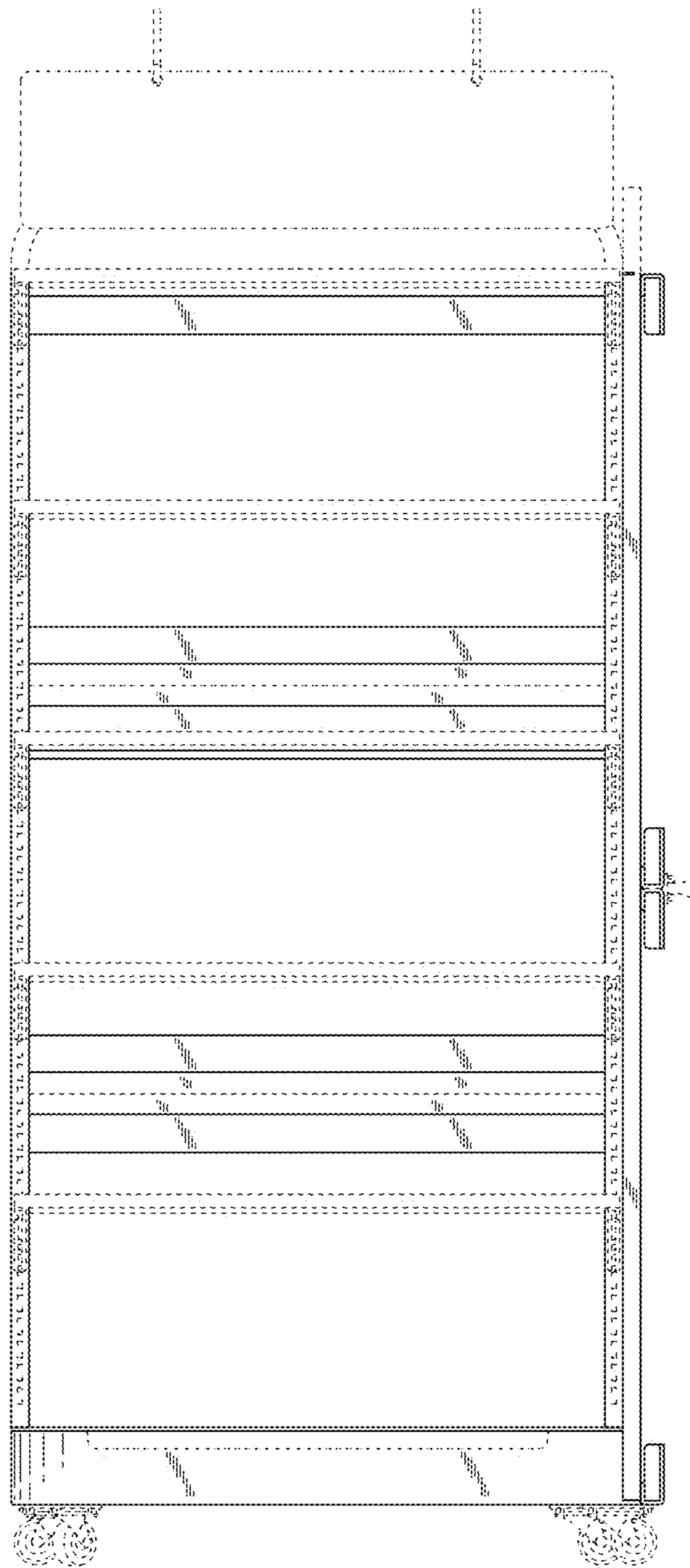

FIG. 9

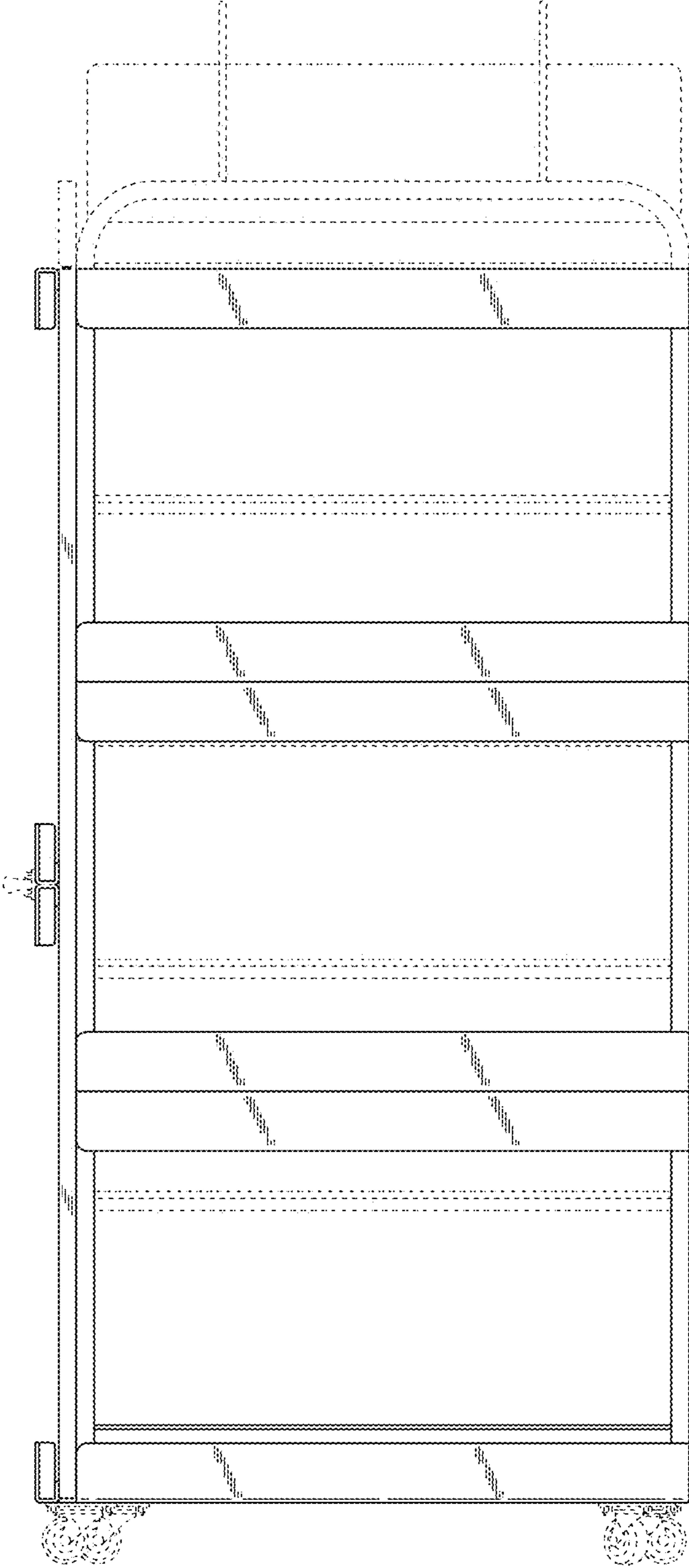

FIG. 10

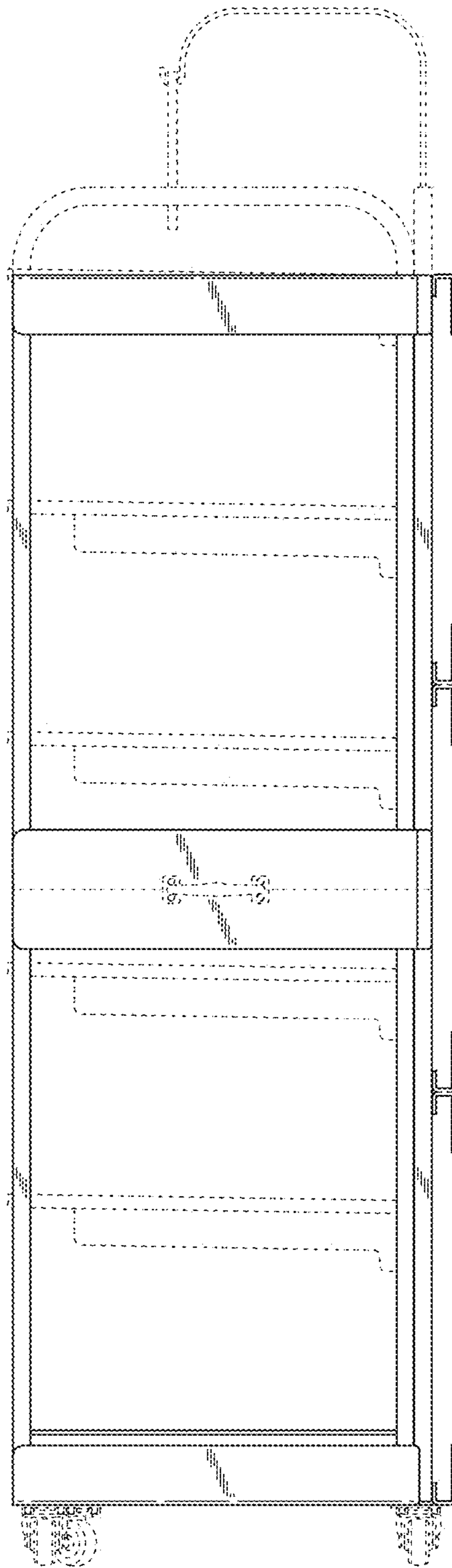

FIG. 11

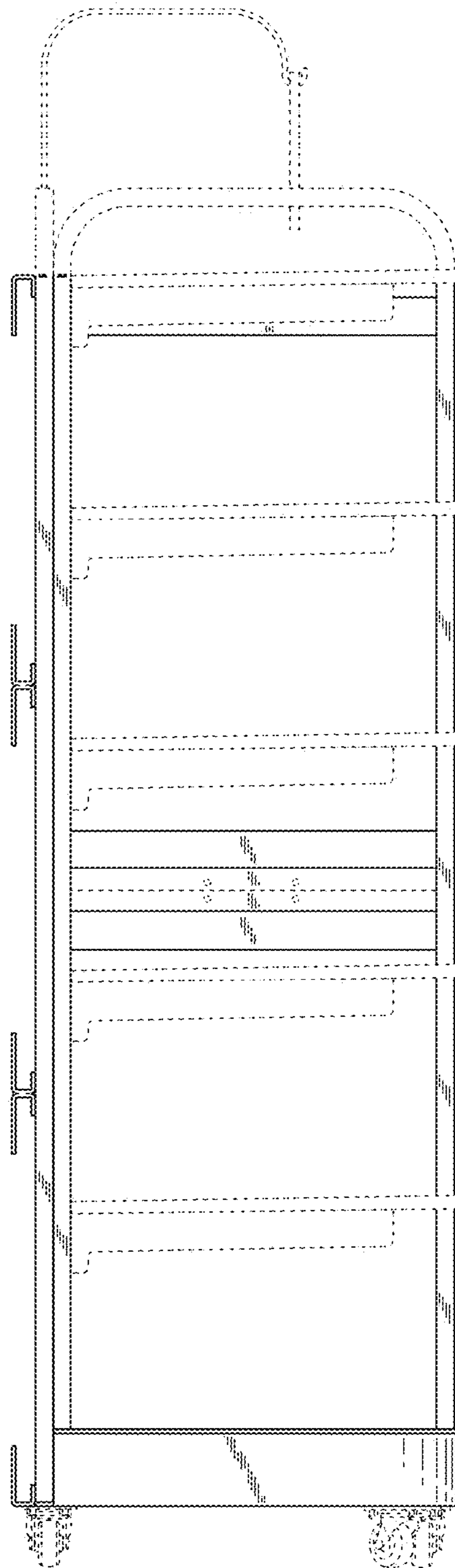

FIG. 12

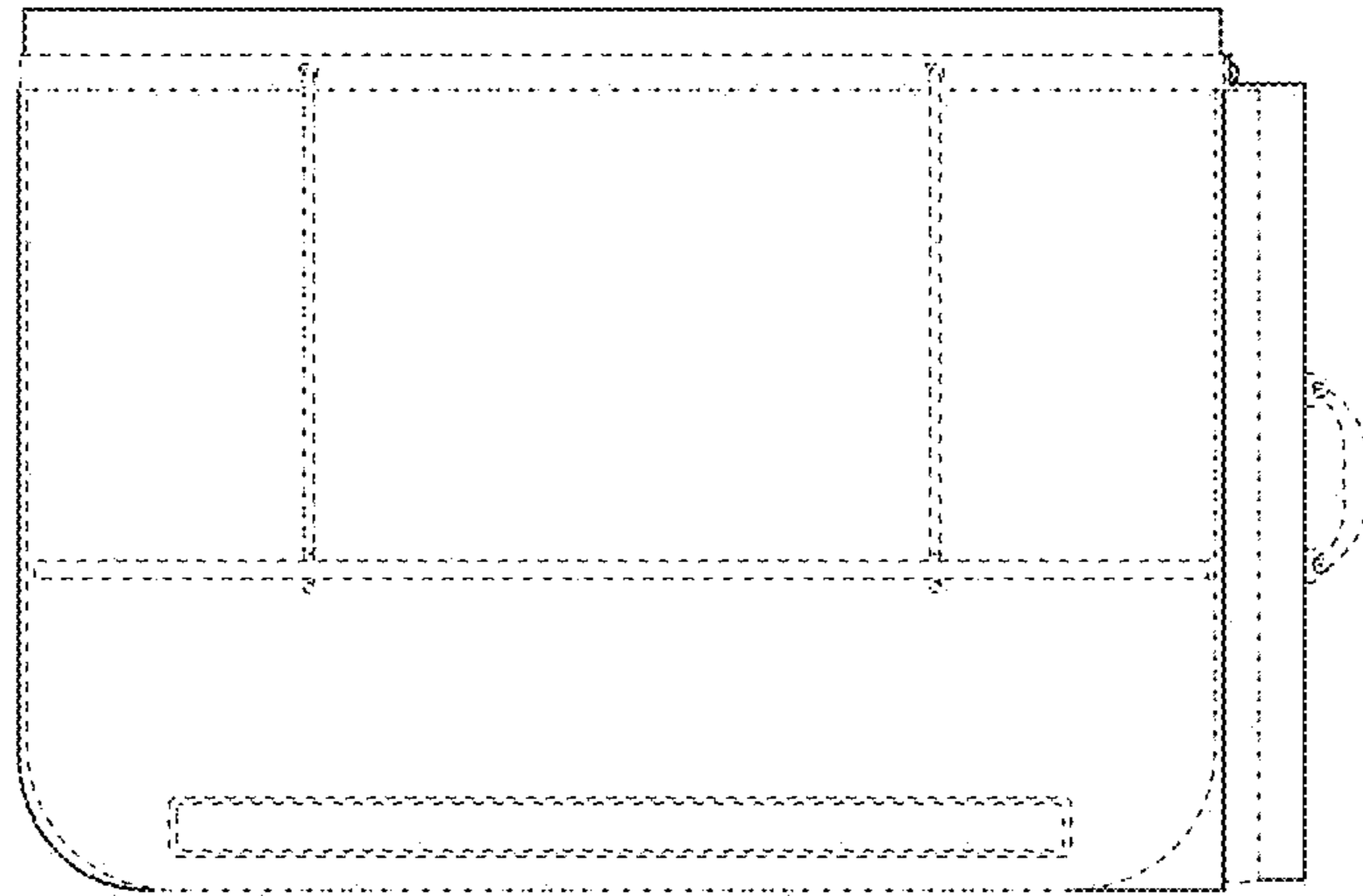

FIG. 13

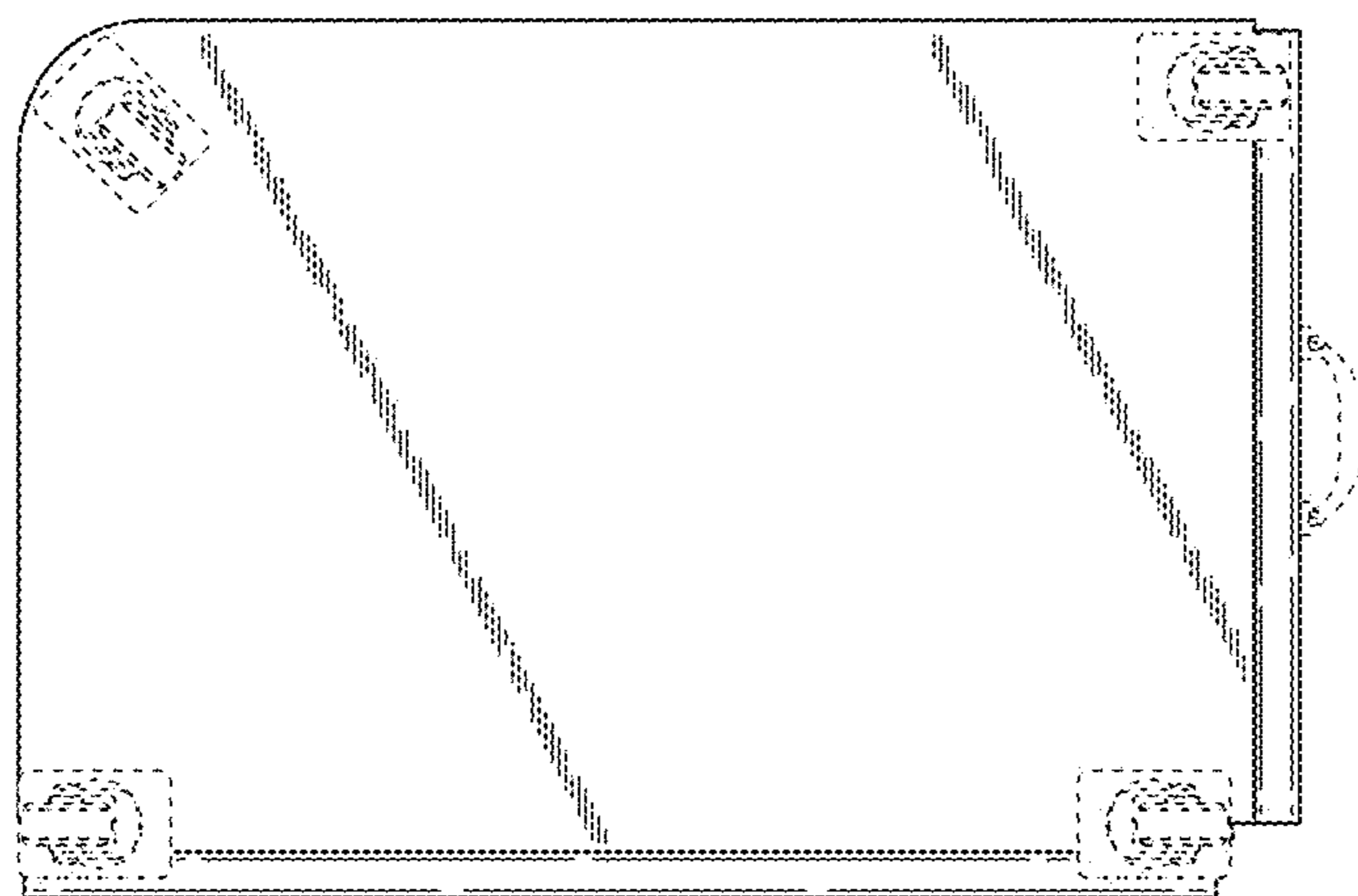

FIG. 14