



US00D751690S

(12) **United States Design Patent**
Peret et al.

(10) **Patent No.:** **US D751,690 S**
(45) **Date of Patent:** **** Mar. 15, 2016**

(54) **APPARATUS TO CONTROL FLUID FLOW THROUGH A TUBE**

(56) **References Cited**

U.S. PATENT DOCUMENTS

(71) Applicant: **DEKA Products Limited Partnership**,
Manchester, NH (US)

2,888,877 A 6/1959 Shellman et al.
3,173,372 A 3/1965 Baldwin
3,384,336 A 5/1968 Pulman
3,609,379 A 9/1971 Hildebrandt

(72) Inventors: **Bob D. Peret**, Bedford, NH (US); **Brian H. Yoo**, Cambridge, MA (US); **Kaitlyn S. Clarke**, Manchester, NH (US);
Thomas A. Friedrich, Loudon, NH (US)

(Continued)

FOREIGN PATENT DOCUMENTS

(73) Assignee: **DEKA Products Limited Partnership**,
Manchester, NH (US)

AU 2247783 A 6/1985
CA 1213749 A1 11/1986

(Continued)

OTHER PUBLICATIONS

(**) Term: **14 Years**

AAMI and FDA, Infusing Patients Safely: Priority Issues from the AAMI/FDA Infusion Device Summit, Symposium, Oct. 5-6, 2010, pp. 1-48, AAMI, Arlington, VA, USA.

(Continued)

(21) Appl. No.: **29/471,858**

(22) Filed: **Nov. 6, 2013**

Primary Examiner — Wan Laymon
Assistant Examiner — Mark Booker

(51) **LOC (10) Cl.** **24-02**

(74) *Attorney, Agent, or Firm* — James D. Wyninegar, Jr.

(52) **U.S. Cl.**
USPC **D24/111**

(57) **CLAIM**

The ornamental design for an apparatus to control fluid flow through a tube, as shown and described.

(58) **Field of Classification Search**
USPC D24/111, 107, 112, 169; 604/7-9, 19, 604/67, 123-125, 143, 151-152, 154-156, 604/218, 246, 256, 253, 250-251, 108, 604/169; 417/234; 403/380, 381; 206/363-368; D9/526, 529, 668
CPC A61M 5/14232; A61M 5/16831; A61M 5/172; A61M 5/14228; A61M 2205/3365; A61M 2205/3313; A61M 5/145; A61M 5/1689; A61M 5/1413; A61M 5/1415; A61M 2205/3569; G01D 5/2451; G01D 5/3473; Y10S 128/13

DESCRIPTION

FIG. 1 is a front, bottom, and right side perspective view of the apparatus to control fluid flow through a tube, showing my new design;
FIG. 2 is a front, top, and left side perspective view thereof;
FIG. 3 is a bottom plan view thereof;
FIG. 4 is a top plan view thereof;
FIG. 5 is a left side elevational view thereof;
FIG. 6 is a right side elevational view thereof;
FIG. 7 is a front side elevational view thereof; and,
FIG. 8 is a back side elevational view thereof.
The ornamental design which is claimed is shown in solid lines in the drawings. The broken lines shown in the figures represent portions of the article that form no part of the claimed design.

See application file for complete search history.

1 Claim, 8 Drawing Sheets

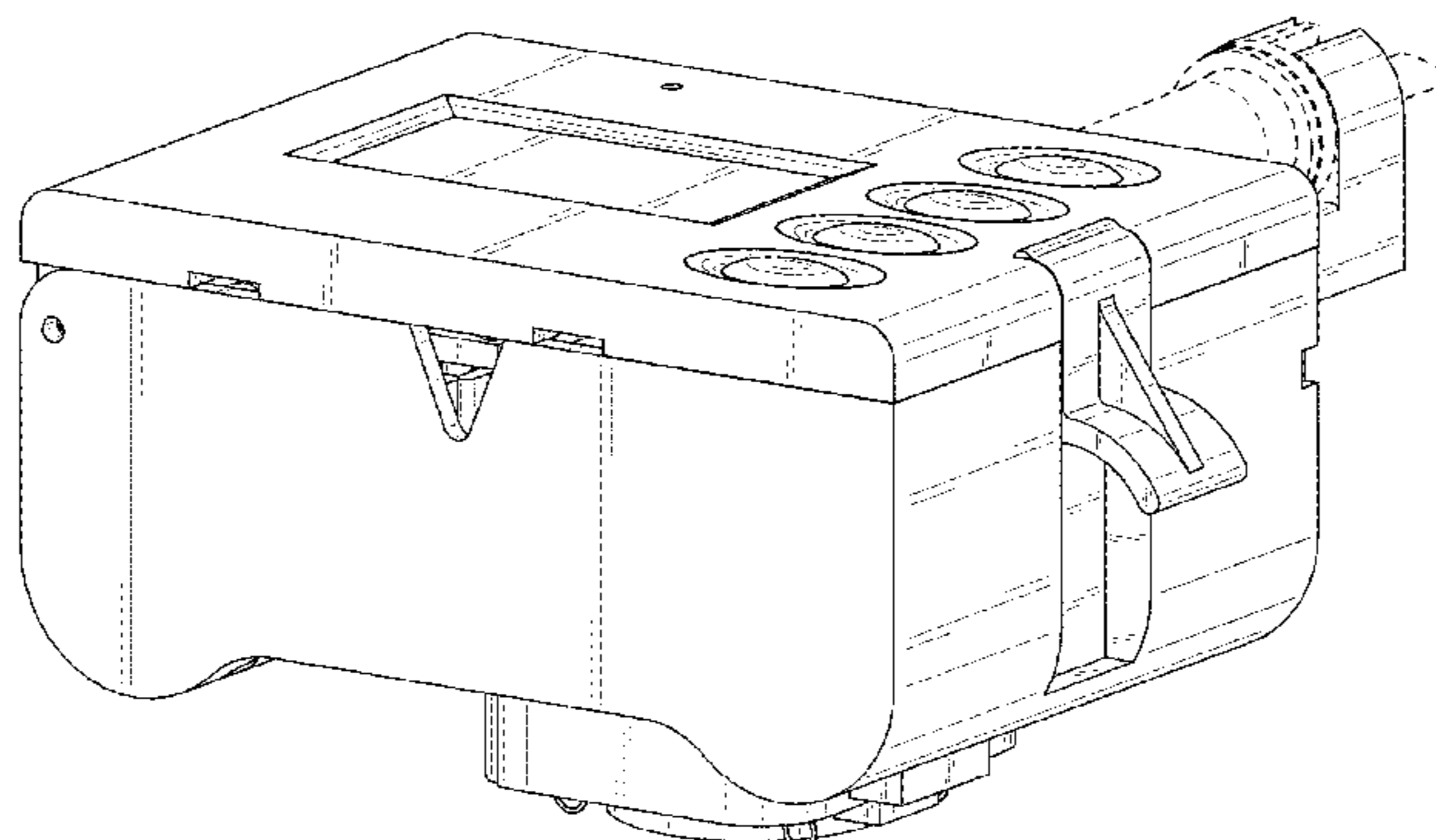

(56) **References Cited**

 U.S. PATENT DOCUMENTS

<p>3,685,787 A 8/1972 Adelberg</p> <p>3,733,149 A 5/1973 Jacobson</p> <p>3,790,042 A 2/1974 McCormick et al.</p> <p>3,831,600 A 8/1974 Yum et al.</p> <p>4,038,982 A 8/1977 Burke et al.</p> <p>4,105,028 A 8/1978 Sadlier et al.</p> <p>4,155,362 A 5/1979 Jess</p> <p>4,303,376 A 12/1981 Siekmann</p> <p>4,321,461 A 3/1982 Walter, Jr. et al.</p> <p>4,328,800 A 5/1982 Marx et al.</p> <p>4,328,801 A 5/1982 Marx et al.</p> <p>4,397,642 A 8/1983 Lamadrid</p> <p>4,421,506 A 12/1983 Danby et al.</p> <p>4,449,534 A 5/1984 Saul</p> <p>4,469,480 A 9/1984 Figler et al.</p> <p>4,504,263 A 3/1985 Steuer et al.</p> <p>4,525,163 A 6/1985 Slavik et al.</p> <p>4,583,975 A 4/1986 Pekkarinen et al.</p> <p>RE32,294 E 11/1986 Knutte</p> <p>4,634,426 A 1/1987 Kamen</p> <p>4,648,869 A 3/1987 Bobo, Jr.</p> <p>4,662,829 A 5/1987 Nehring</p> <p>4,668,216 A 5/1987 Martin et al.</p> <p>4,673,820 A 6/1987 Kamen</p> <p>4,680,977 A 7/1987 Conero et al.</p> <p>4,703,314 A 10/1987 Spani</p> <p>4,718,896 A 1/1988 Arndt et al.</p> <p>4,720,636 A 1/1988 Benner, Jr.</p> <p>4,820,281 A 4/1989 Lawler, Jr.</p> <p>4,834,744 A 5/1989 Ritson</p> <p>4,837,708 A 6/1989 Wright</p> <p>4,846,792 A 7/1989 Bobo, Jr. et al.</p> <p>4,909,786 A 3/1990 Gijzelhart et al.</p> <p>4,920,336 A 4/1990 Meijer</p> <p>4,936,828 A 6/1990 Chiang</p> <p>4,959,050 A 9/1990 Bobo, Jr.</p> <p>4,979,940 A 12/1990 Bobo, Jr. et al.</p> <p>4,981,467 A 1/1991 Bobo, Jr. et al.</p> <p>5,002,539 A 3/1991 Coble et al.</p> <p>5,045,069 A 9/1991 Imparato</p> <p>5,057,090 A 10/1991 Bessman</p> <p>5,154,704 A 10/1992 Archibald</p> <p>5,181,910 A * 1/1993 Scanlon A61M 5/172 128/DIG. 12</p> <p>5,186,057 A 2/1993 Everhart</p> <p>RE34,413 E 10/1993 McCullough</p> <p>5,267,980 A 12/1993 Dirr, Jr. et al.</p> <p>5,314,316 A 5/1994 Shibamoto et al.</p> <p>5,328,341 A 7/1994 Forni</p> <p>5,331,309 A 7/1994 Sakai</p> <p>5,415,641 A 5/1995 Yerlikaya et al.</p> <p>5,482,446 A 1/1996 Williamson et al.</p> <p>5,562,615 A 10/1996 Nassif</p> <p>5,588,963 A 12/1996 Roelofs</p> <p>5,718,562 A * 2/1998 Lawless A61M 5/1413 361/730</p> <p>5,753,820 A 5/1998 Reed et al.</p> <p>5,782,805 A * 7/1998 Meinzer A61M 5/172 604/131</p> <p>5,800,140 A 9/1998 Forni</p> <p>5,899,665 A 5/1999 Makino et al.</p> <p>6,049,381 A 4/2000 Reintjes et al.</p> <p>6,050,713 A 4/2000 O'Donnell et al.</p> <p>6,083,206 A 7/2000 Molko</p> <p>6,110,153 A 8/2000 Davis et al.</p> <p>6,149,631 A 11/2000 Haydel, Jr.</p> <p>6,159,186 A 12/2000 Wickham et al.</p> <p>6,213,354 B1 4/2001 Kay</p> <p>6,228,047 B1 5/2001 Dadson</p> <p>D446,860 S * 8/2001 Meziere D24/169</p> <p>6,305,908 B1 * 10/2001 Hermann A61M 5/14244 417/234</p> <p>6,328,712 B1 12/2001 Cartledge</p> <p>6,362,887 B1 3/2002 Meisberger</p> <p>6,500,151 B1 12/2002 Cobb et al.</p>	<p>6,503,221 B1 * 1/2003 Briggs F04B 43/08 604/151</p> <p>6,523,414 B1 2/2003 Malmstrom et al.</p> <p>6,562,012 B1 5/2003 Brown et al.</p> <p>6,599,282 B2 7/2003 Burko</p> <p>6,641,556 B1 11/2003 Shigezawa</p> <p>6,657,545 B1 12/2003 Lin et al.</p> <p>6,736,801 B1 5/2004 Gallagher</p> <p>6,984,052 B1 1/2006 Del Castillo</p> <p>7,001,365 B2 2/2006 Makkink</p> <p>7,190,275 B2 3/2007 Goldberg et al.</p> <p>7,338,475 B2 3/2008 Brown</p> <p>7,498,563 B2 3/2009 Mandro et al.</p> <p>7,499,581 B2 3/2009 Tribble et al.</p> <p>7,540,859 B2 6/2009 Claude et al.</p> <p>7,695,448 B2 4/2010 Cassidy et al.</p> <p>7,767,991 B2 8/2010 Sacchetti</p> <p>7,892,204 B2 2/2011 Kraus</p> <p>7,905,859 B2 * 3/2011 Bynum A61M 5/14244 604/131</p> <p>7,918,834 B2 4/2011 Mernoe et al.</p> <p>7,933,780 B2 4/2011 De La Huerga</p> <p>8,025,634 B1 9/2011 Moubayed et al.</p> <p>8,038,657 B2 10/2011 Davis et al.</p> <p>8,147,448 B2 4/2012 Sundar et al.</p> <p>8,147,464 B2 4/2012 Spohn et al.</p> <p>8,256,984 B2 * 9/2012 Fathallah A61M 5/1413 403/380</p> <p>8,529,511 B2 * 9/2013 Boulanger A61M 5/14232 604/151</p> <p>8,531,517 B2 9/2013 Tao</p> <p>8,552,361 B2 * 10/2013 Mandro A61M 5/145 250/231.13</p> <p>8,622,979 B2 1/2014 Hungerford et al.</p> <p>8,834,429 B2 * 9/2014 Grant A61M 5/1456 604/131</p> <p>2002/0194933 A1 12/2002 Roelofs</p> <p>2003/0045840 A1 3/2003 Burko</p> <p>2003/0055406 A1 * 3/2003 Lebel A61N 1/37211 604/891.1</p> <p>2003/0217962 A1 11/2003 Childers et al.</p> <p>2004/0171994 A1 9/2004 Goldberg et al.</p> <p>2005/0171491 A1 8/2005 Minh Miner et al.</p> <p>2006/0140466 A1 6/2006 Seshimo et al.</p> <p>2006/0291211 A1 12/2006 Rodriguez et al.</p> <p>2008/0004574 A1 1/2008 Dyar et al.</p> <p>2008/0051732 A1 2/2008 Chen</p> <p>2008/0147008 A1 6/2008 Lewis et al.</p> <p>2008/0147016 A1 6/2008 Faries et al.</p> <p>2008/0154214 A1 * 6/2008 Spohn A61M 5/007 604/247</p> <p>2008/0235765 A1 9/2008 Shimizu</p> <p>2009/0112115 A1 4/2009 Huang et al.</p> <p>2009/0224638 A1 9/2009 Weber</p> <p>2009/0254025 A1 * 10/2009 Simmons A61M 5/1456 604/67</p> <p>2009/0276167 A1 11/2009 Glaser et al.</p> <p>2009/0281460 A1 11/2009 Lowery et al.</p> <p>2010/0097451 A1 4/2010 Bruce et al.</p> <p>2010/0114027 A1 5/2010 Jacobson et al.</p> <p>2010/0168671 A1 7/2010 Faries, Jr. et al.</p> <p>2010/0211003 A1 8/2010 Sundar et al.</p> <p>2010/0292635 A1 11/2010 Sundar</p> <p>2010/0309005 A1 12/2010 Warner et al.</p> <p>2011/0004186 A1 1/2011 Butterfield</p> <p>2011/0125103 A1 5/2011 Rondeau</p> <p>2011/0166511 A1 7/2011 Sharvit et al.</p> <p>2011/0196306 A1 8/2011 De La Huerga</p> <p>2011/0208123 A1 * 8/2011 Gray A61M 5/14244 604/151</p> <p>2011/0231204 A1 9/2011 De La Huerga</p> <p>2011/0251557 A1 * 10/2011 Powers A61M 5/168 604/151</p> <p>2011/0313789 A1 12/2011 Kamen et al.</p> <p>2012/0013735 A1 1/2012 Tao</p> <p>2012/0059318 A1 3/2012 Dewey</p> <p>2012/0059350 A1 3/2012 Siefert</p> <p>2012/0095415 A1 4/2012 Sharvit et al.</p> <p>2012/0095433 A1 4/2012 Hungerford et al.</p>
---	--

(56)

References Cited

U.S. PATENT DOCUMENTS

2012/0185267 A1 7/2012 Kamen et al.
 2012/0197185 A1 8/2012 Tao
 2012/0238997 A1 9/2012 Dewey
 2012/0265166 A1* 10/2012 Yodfat A61M 5/1413
 604/506
 2012/0310153 A1* 12/2012 Moberg A61M 5/14566
 604/67
 2013/0035659 A1 2/2013 Hungerford et al.
 2013/0177455 A1 7/2013 Kamen et al.
 2013/0182381 A1 7/2013 Gray et al.
 2013/0184676 A1 7/2013 Kamen et al.
 2013/0188040 A1 7/2013 Kamen et al.
 2013/0191513 A1 7/2013 Kamen et al.
 2013/0197693 A1 8/2013 Kamen et al.
 2013/0201482 A1 8/2013 Munro
 2013/0204188 A1 8/2013 Kamen et al.
 2013/0253442 A1* 9/2013 Travis A61M 39/28
 604/250
 2013/0272773 A1 10/2013 Kamen et al.
 2013/0281965 A1 10/2013 Kamen et al.
 2013/0297330 A1 11/2013 Kamen et al.
 2013/0310990 A1 11/2013 Peret et al.
 2013/0317753 A1 11/2013 Kamen et al.
 2013/0317837 A1 11/2013 Ballantyne et al.
 2013/0336814 A1 12/2013 Kamen et al.
 2013/0339049 A1 12/2013 Blumberg, Jr. et al.
 2013/0346108 A1 12/2013 Kamen et al.
 2014/0081233 A1 3/2014 Hungerford et al.
 2014/0135695 A1* 5/2014 Grant A61M 5/14244
 604/111
 2014/0148757 A1* 5/2014 Ambrosina A61M 5/38
 604/67
 2014/0165703 A1 6/2014 Wilt et al.
 2014/0180711 A1 6/2014 Kamen et al.
 2014/0194818 A1* 7/2014 Yodfat A61M 5/1413
 604/151
 2014/0227021 A1 8/2014 Kamen et al.
 2014/0309612 A1* 10/2014 Smisson, III A61M 1/0281
 604/500
 2014/0318639 A1 10/2014 Peret et al.
 2015/0002667 A1 1/2015 Peret et al.
 2015/0002668 A1 1/2015 Peret et al.
 2015/0002677 A1 1/2015 Peret et al.

FOREIGN PATENT DOCUMENTS

DE 2023027 11/1970
 DE 3617723 A1 12/1987
 DE 3822057 C2 1/1989
 DE 69229832 T2 2/2000
 EP 0112699 A2 7/1984
 EP 1722310 A1 4/2005
 EP 2319551 A2 10/2008
 FR 2042606 A1 2/1971
 FR 2458804 1/1981
 FR 2617593 1/1989
 GB 1301033 A 12/1972
 GB 2020735 A 11/1979
 GB 2207239 B 1/1989
 GB 2328982 B 3/1999
 JP S58163843 9/1983
 JP 3110458 B2 11/2000
 JP 2011 062371 A 3/2011
 NL 7006908 11/1970
 NL 8801680 2/1989
 NL 9101825 A 5/1993
 SE 376843 6/1975
 WO WO 81/02770 A1 10/1981
 WO WO 93/09407 A1 5/1993
 WO WO 00/72181 A2 11/2000
 WO WO 02/40084 A2 5/2002
 WO WO 02/0100262 A1 12/2002
 WO WO 2004/035116 A1 4/2004
 WO WO 2005/094919 A1 10/2005

WO WO 2006/086723 A2 8/2006
 WO WO 2008/022880 A1 2/2008
 WO WO 2008/079023 A1 7/2008
 WO WO 2009/039203 A2 3/2009
 WO WO 2009/039214 A2 3/2009
 WO WO 2009/055639 A2 4/2009
 WO WO 2010/129720 A2 11/2010
 WO WO 2011/021098 A1 2/2011
 WO WO 2011/136667 A1 11/2011
 WO WO 2013/095459 A9 6/2013
 WO WO 2013/096713 A2 6/2013
 WO WO 2013/096718 A2 6/2013
 WO WO 2013/096722 A2 6/2013
 WO WO 2013/096909 A2 6/2013

OTHER PUBLICATIONS

Conway, "Analytical Analysis of Tip Travel in a Bourdon Tube", Master's Thesis, Naval Postgraduate School Monterey, Dec. 1995, pp. i-89.
 "Principles of Flow Cytometry: An Overview." Methods in Cell Biology: Cytometry. Ed. Zbigniew Darzynkiewicz. 3rd ed. vol. 63. Academic, 2000. 44-48.
 "Feature Detection", *OpenCV Wiki, 2010*, 7 pgs, http://opencv.willowgarage.com/documentation/cpp/imgproc_feature_detection.html.
 Galambos et al., "Progressive Probabilistic Hough Transform for Line Detection", IEEE, 7 pgs, 1999.
 International Search Report & Written Opinion dated May 14, 2012, received in International patent application No. PCT/US2011/066588 (197WO), 9 pgs.
 International Search Report & Written Opinion dated Jun. 18, 2013, received in International patent application No. PCT/US2012/071142 (J79WO), 14 pgs.
 International Search Report & Written Opinion dated Oct. 1, 2013, received in International patent application No. PCT/US2012/071490 (J76WO), 19 pgs.
 International Search Report & Written Opinion dated Dec. 4, 2013, received in International patent application No. PCT/US2013/032445 (K14WO), 20 pgs.
 International Search Report & Written Opinion dated Nov. 7, 2013, received in International patent application No. PCT/US2013/042350 (K66WO), 18 pgs.
 Invitation to Pay Additional Fees and, Where Applicable, Protest Fee dated Sep. 9, 2013, received in International patent application No. PCT/US2013/032445 (K14WO), 10 pgs.
 Invitation to Pay Additional Fees and, Where Applicable, Protest Fee dated Sep. 26, 2013, received in International patent application No. PCT/US2013/042350 (K66WO), 7 pgs.
 Hofmann, "Modeling Medical Devices for Plug-and-Play Interoperability", MIT Department of Electrical Engineering and Computer Science, Jun. 2007, pp. 1-187.
 King et al. *Prototyping closed loop physiologic control with the medical device coordination framework*. In *SEHC 2010: Proceedings of the 2010 ICSE Workshop on Software Engineering in Health Care* (pp. 1-11). New York, NY: ACM. (2010).
 Jetley et al., "Safety Requirements Based Analysis of Infusion Pump Software", Proceedings of the IEEE Real Time Systems Symposium, Tuscon, Dec. 2007 pp. 1-4.
 FDA US Food and Drug Administration, "SEDASYS® Computer-Assisted Personalized Sedation System—P08000", Jul. 16, 2013, pp. 1-2, www.fda.gov/MedicalDevices/ProductsandMedicalProcedures/DeviceApprovalsandClearances/Recently-ApprovedDevices/ucm353950.htm.
 Luerkens, David W. "Theory and Application of Morphological Analysis: Fine Particles and Surfaces". Boca Raton: CRC, 1991. 5-7.
 Matas et al., *Progressive Probabilistic Hough Transform*.
 "Miscellaneous Image Transformations", *OpenCV Wiki, 2011*, 9 pgs., http://opencv.willowgarage.com/documentation/cpp/miscellaneous_image_transformations.
 National Patient Safety Agency, *Design for Patient Safety: A Guide to the Design of Electronic Infusion Devices*, booklet, 2010, pp. 1-96, Edition 1, National Patient Safety Agency, London.

(56)

References Cited

OTHER PUBLICATIONS

“Object Detection”, OpenCV Wiki, 2011, 2 pgs., http://opencv.wil-lowgarage.com/documentation/cpp/object_detection.html.

“The OpenCV Reference Manual Release 2.4.6.0”, Jul. 1, 2013, pp. 1-813.

Leor et al., “A System for the Measurement of Drop Volume of Intra-venous Solutions”, Proceedings Computers in Cardiology 1990, pp. 405-406, Los Alamitos, California.

Butterfield, “Alaris SE Pump, Monitoring and Detection of IV Line Occlusions.”, CareFusion Corporation, 2010, 4 pgs.

“Vista Basic: Instructions for Use: Software IFVB”, manual, 2002, pgs. 3, B. Braun Medical Inc.

Hugli et al., “Drop volume measurement by vision.” Proceedings of SPIE Electronic Imaging Conference, San Diego, Jan. 2000. SPIE vol. 3866-11, pp. 60-66.

* cited by examiner

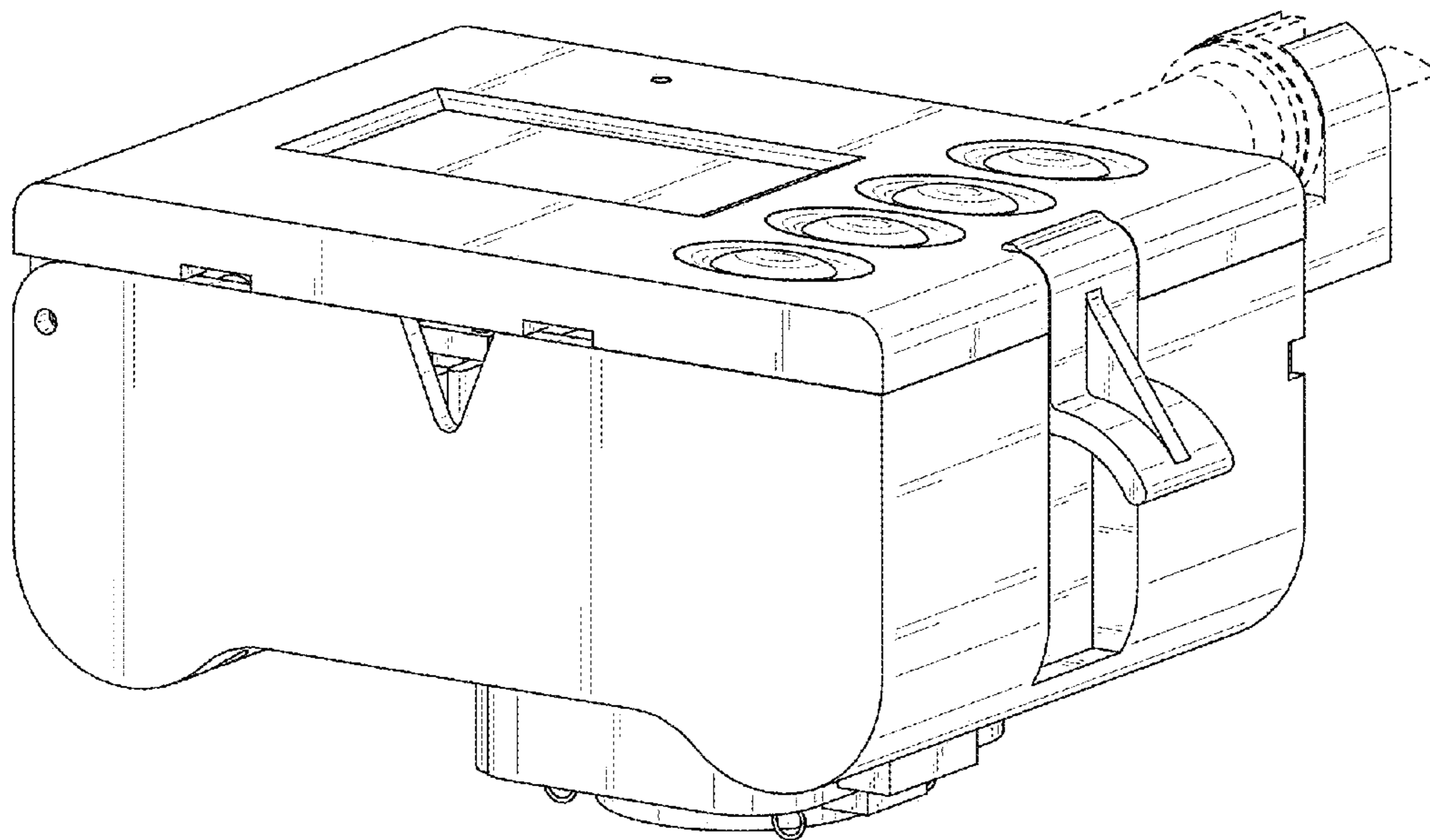

FIG. 1

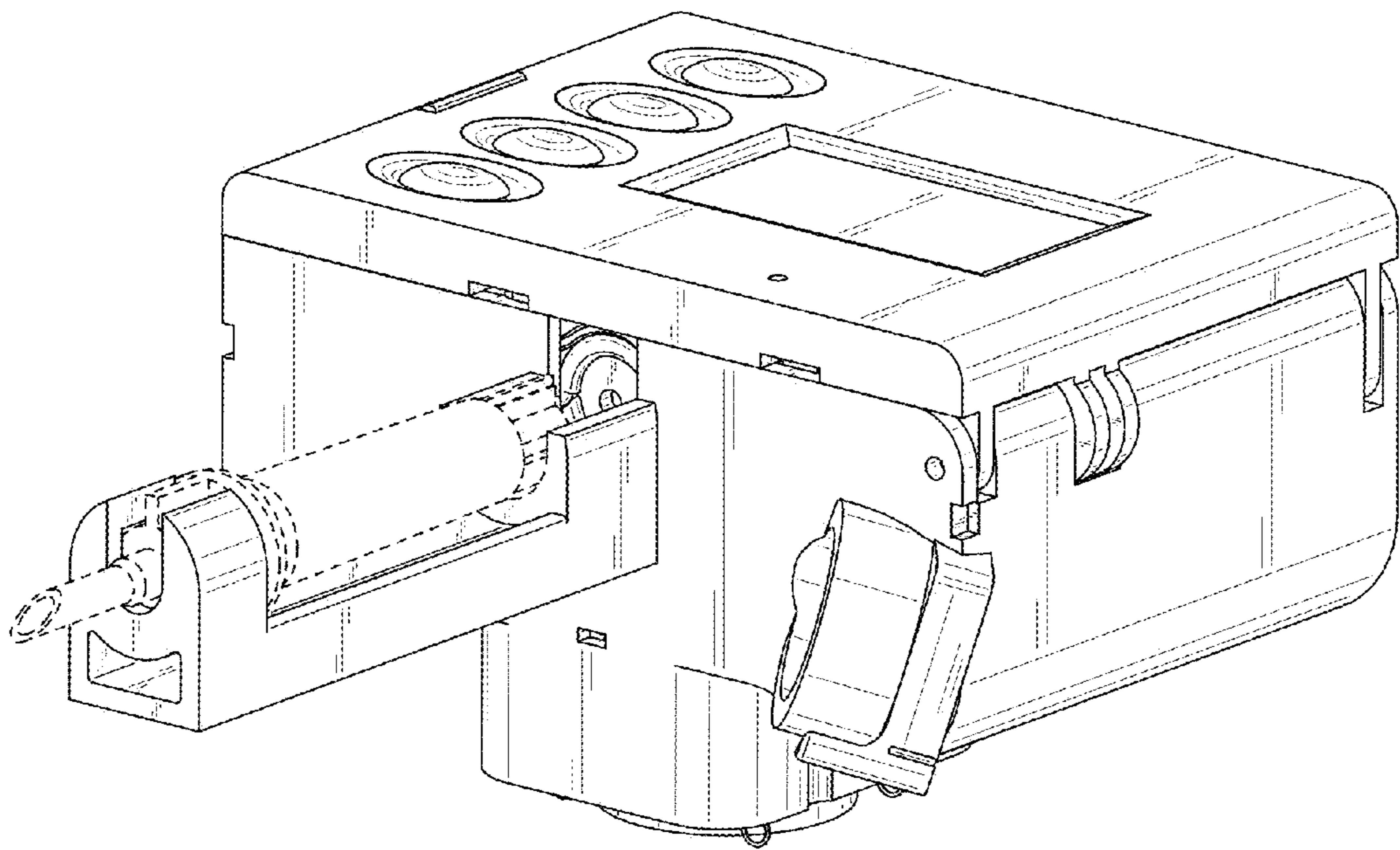

FIG. 2

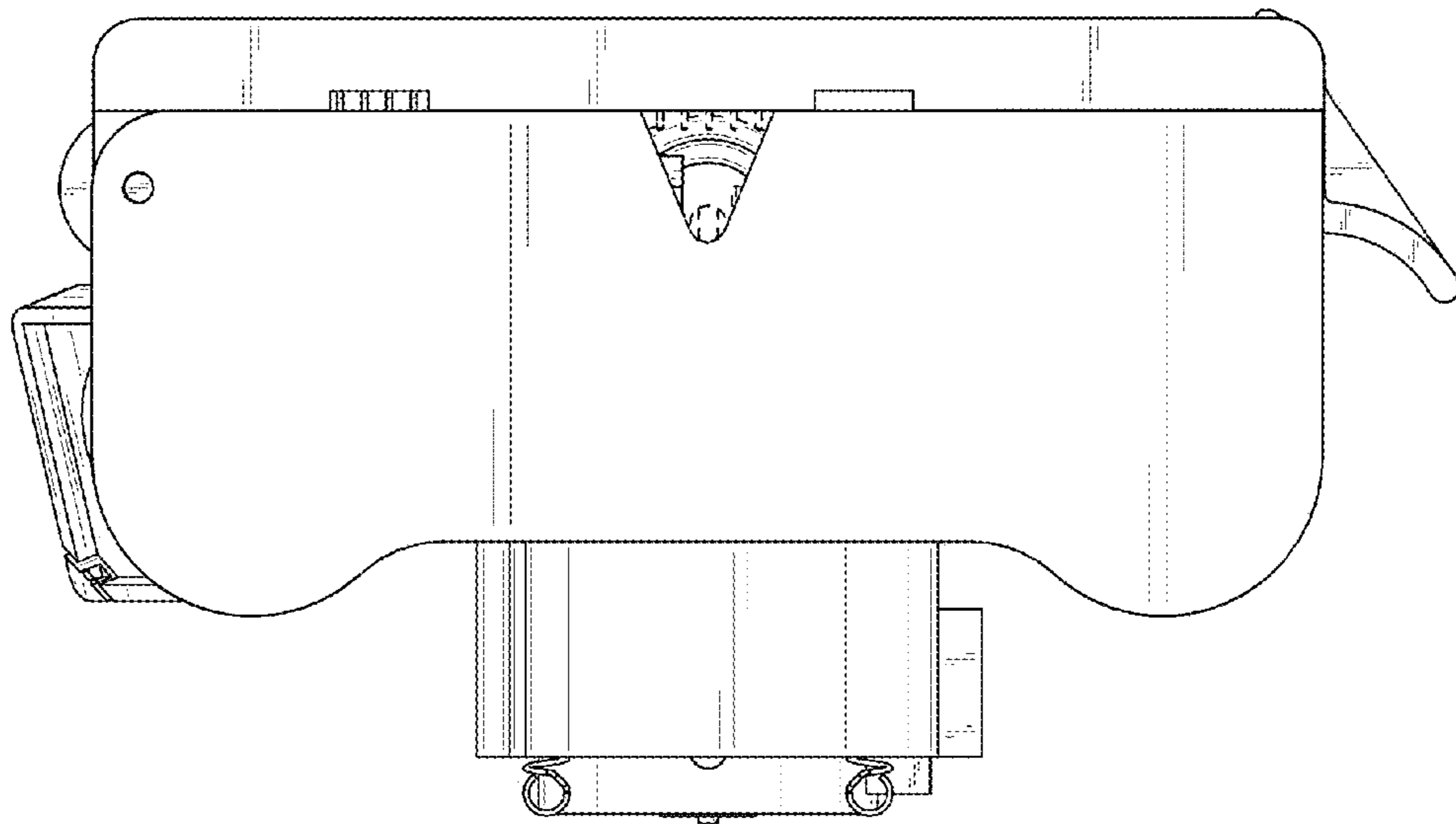

FIG. 3

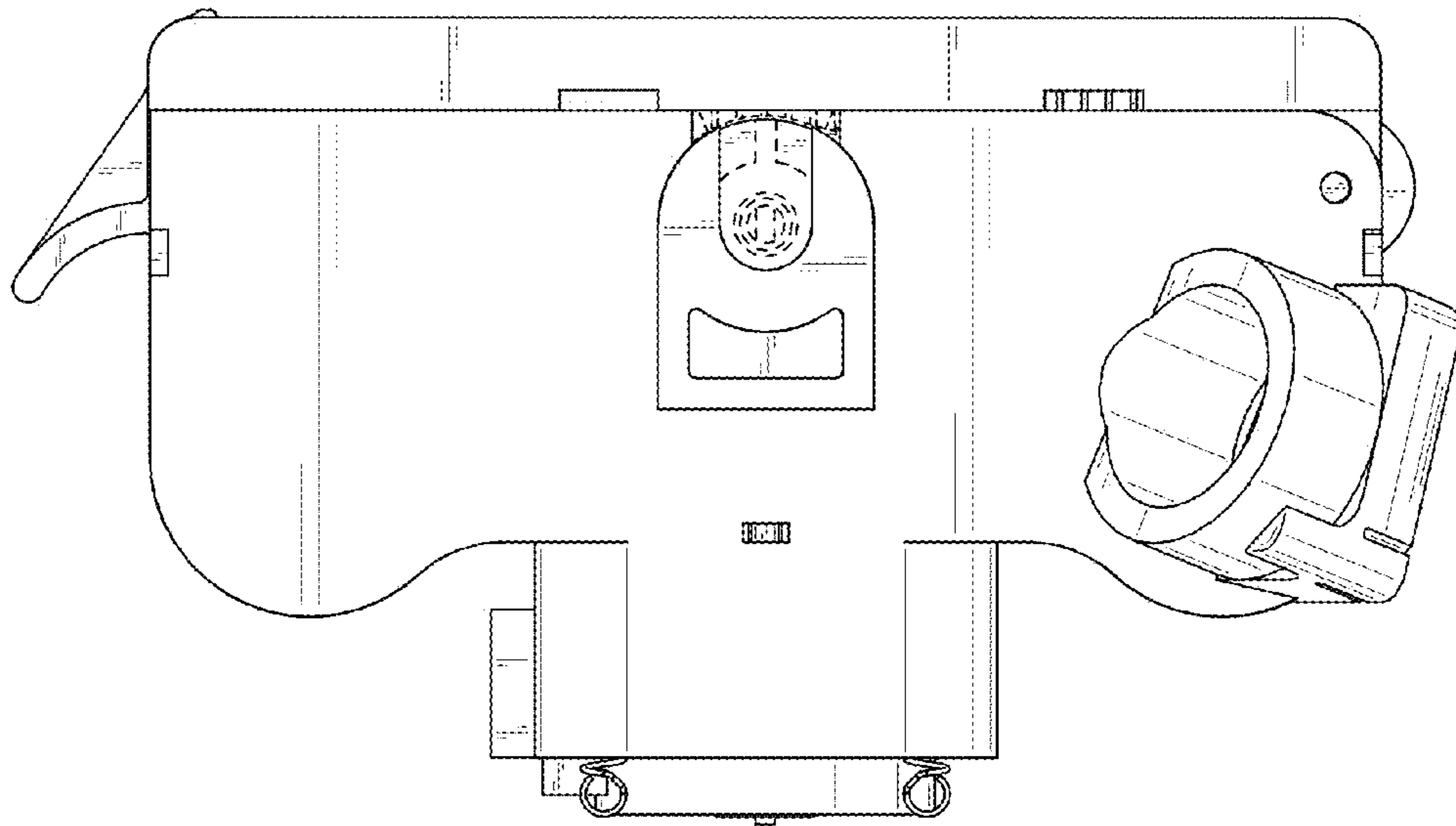

FIG. 4

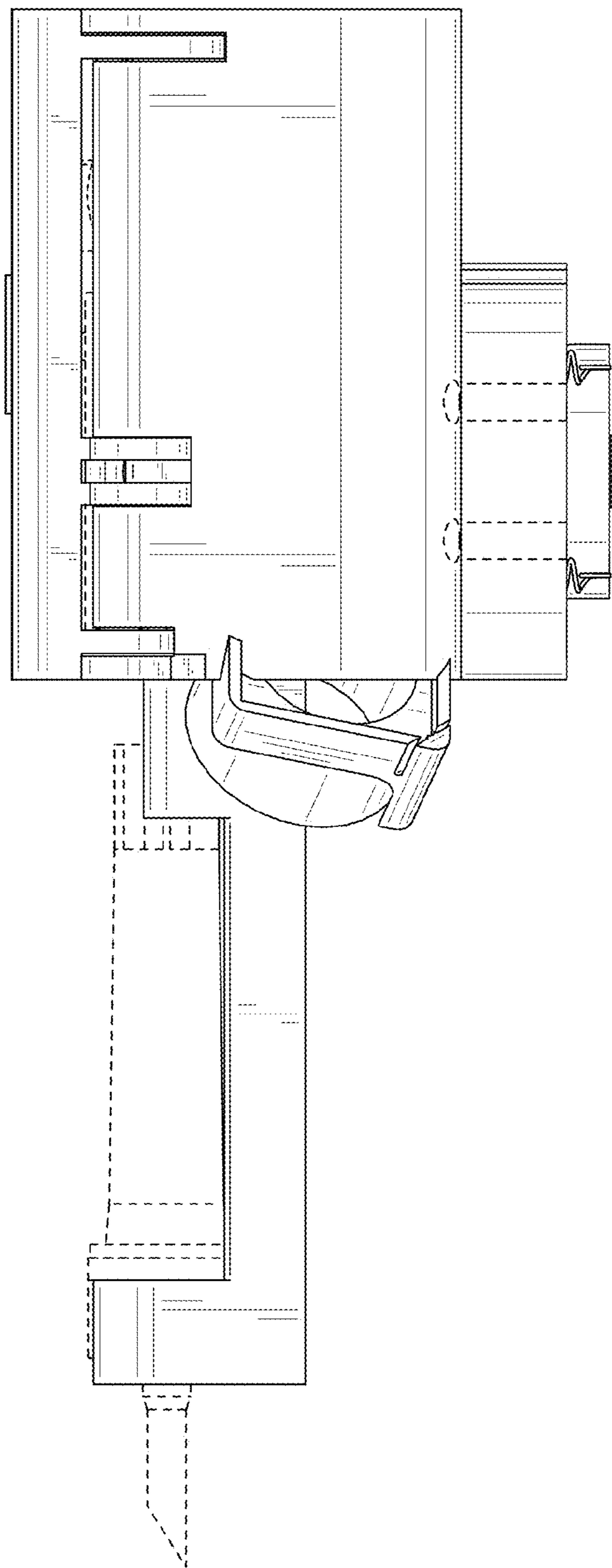

FIG. 5

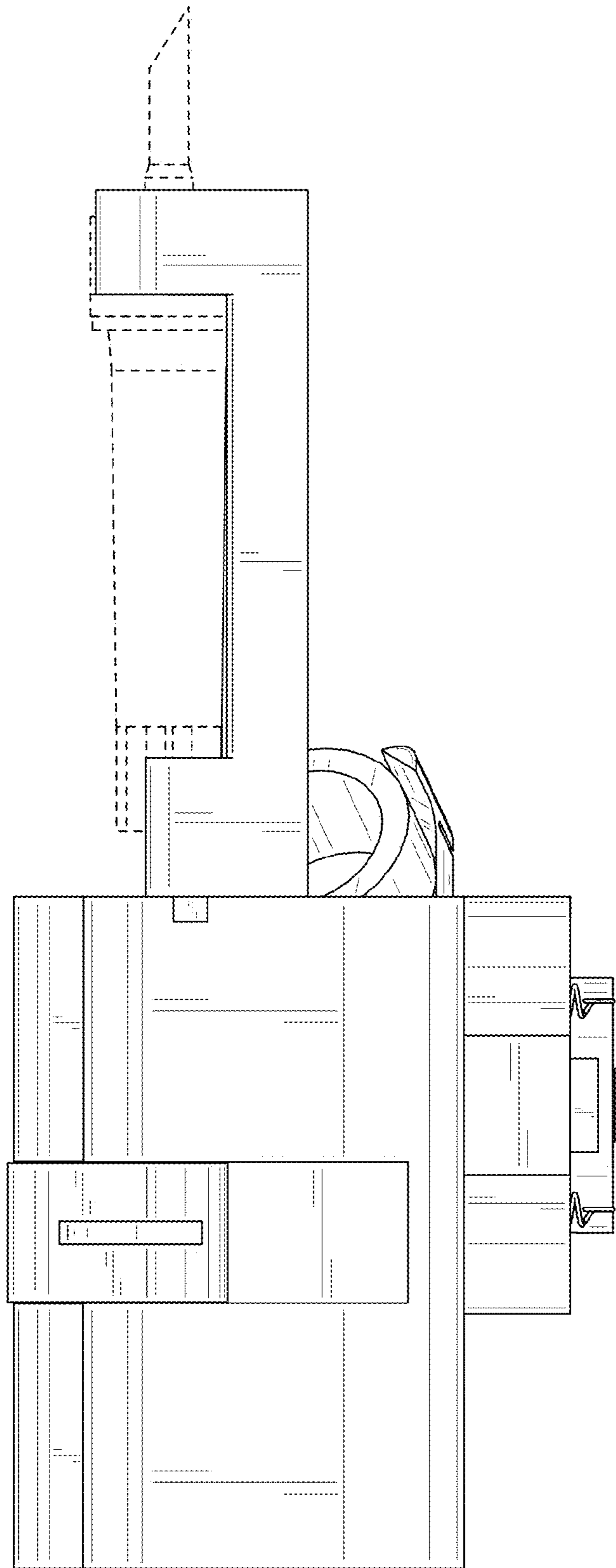

FIG. 6

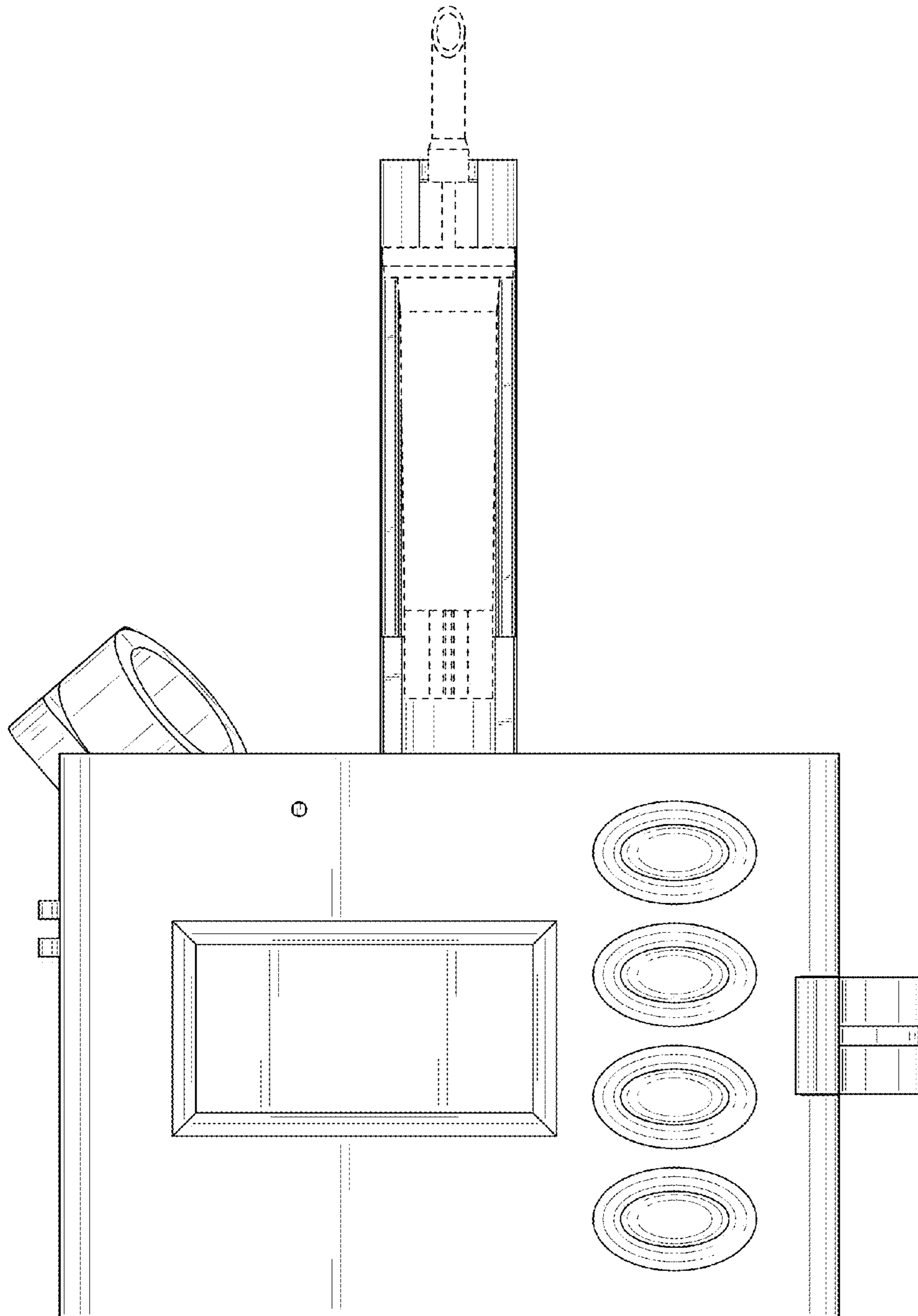

FIG. 7

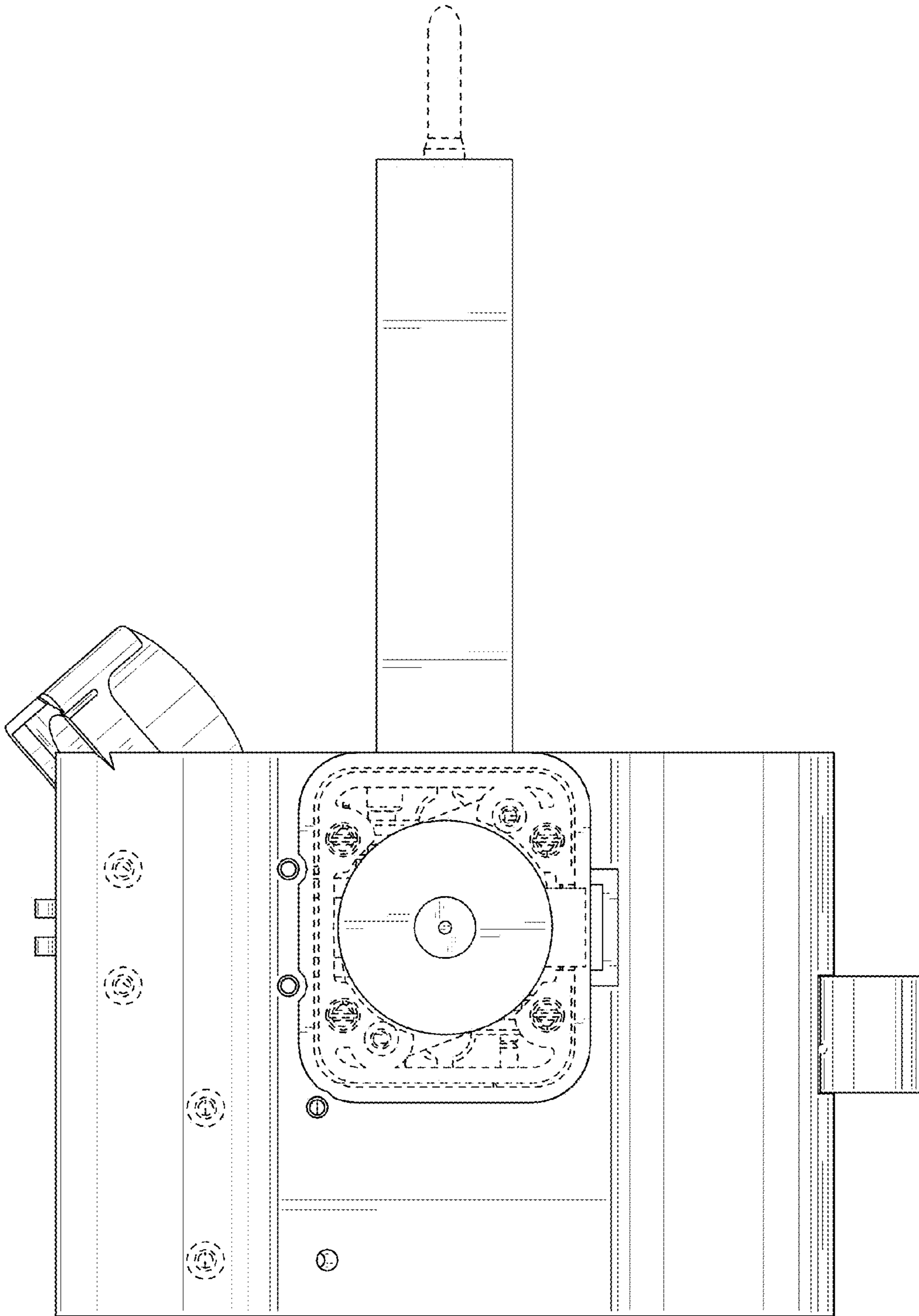

FIG. 8