



US00D751689S

(12) **United States Design Patent**
Peret et al.

(10) **Patent No.:** **US D751,689 S**
(45) **Date of Patent:** **** Mar. 15, 2016**

(54) **APPARATUS TO CONTROL FLUID FLOW THROUGH A TUBE**

3,384,336 A 5/1968 Pulman
3,609,379 A 9/1971 Hildebrandt
3,685,787 A 8/1972 Adelberg

(71) Applicant: **DEKA Products Limited Partnership**,
Manchester, NH (US)

(Continued)

(72) Inventors: **Bob D. Peret**, Bedford, NH (US); **Brian H. Yoo**, Cambridge, MA (US); **Kaitlyn S. Clarke**, Manchester, NH (US); **Thomas A. Friedrich**, Loudon, NH (US); **Derek G. Kane**, Manchester, NH (US)

FOREIGN PATENT DOCUMENTS

AU 2247783 A 6/1985
CA 1213749 A1 11/1986

(Continued)

(73) Assignee: **DEKA Products Limited Partnership**,
Manchester, NH (US)

OTHER PUBLICATIONS

AAMI and FDA, Infusing Patients Safely: Priority Issues from the AAMI/FDA Infusion Device Summit, Symposium, Oct. 5-6, 2010, pp. 1-48, AAMI, Arlington, VA, USA.

(Continued)

(**) Term: **14 Years**

Primary Examiner — Wan Laymon

(21) Appl. No.: **29/471,856**

Assistant Examiner — Mark Booker

(22) Filed: **Nov. 6, 2013**

(74) *Attorney, Agent, or Firm* — James D. Wyninegar, Jr.

(51) **LOC (10) Cl.** **24-02**

(57) **CLAIM**

(52) **U.S. Cl.**

The ornamental design for an apparatus to control fluid flow through a tube, as shown and described.

USPC **D24/111**

DESCRIPTION

(58) **Field of Classification Search**

USPC D24/111, 107, 112, 169; 604/218, 246, 604/256, 253, 250-251, 108, 169; 417/234; 206/363-368; D9/526, 529, 668
CPC A61M 5/14232; A61M 5/16831; A61M 5/172; A61M 5/14228; A61M 2205/3365; A61M 2205/3313; A61M 5/145; A61M 5/1689; A61M 5/1413; A61M 5/1415; A61M 2205/3569; G01D 5/2451; G01D 5/3473; Y10S 128/13

See application file for complete search history.

FIG. 1 is a front, bottom, and right side perspective view of the apparatus to control fluid flow through a tube, showing my new design;
FIG. 2 is a front, top, and left side perspective view thereof;
FIG. 3 is a bottom plan view thereof;
FIG. 4 is a top plan view thereof;
FIG. 5 is a left side elevational view thereof;
FIG. 6 is a right side elevational view thereof;
FIG. 7 is an enlarged front side elevational view thereof; and,
FIG. 8 is an enlarged back side elevational view thereof.

(56) **References Cited**

U.S. PATENT DOCUMENTS

2,888,877 A 6/1959 Shellman et al.
3,173,372 A 3/1965 Baldwin

The ornamental design which is claimed is shown in solid lines in the drawings. The broken lines shown in the figures represent portions of the article that form no part of the claimed design.

1 Claim, 8 Drawing Sheets

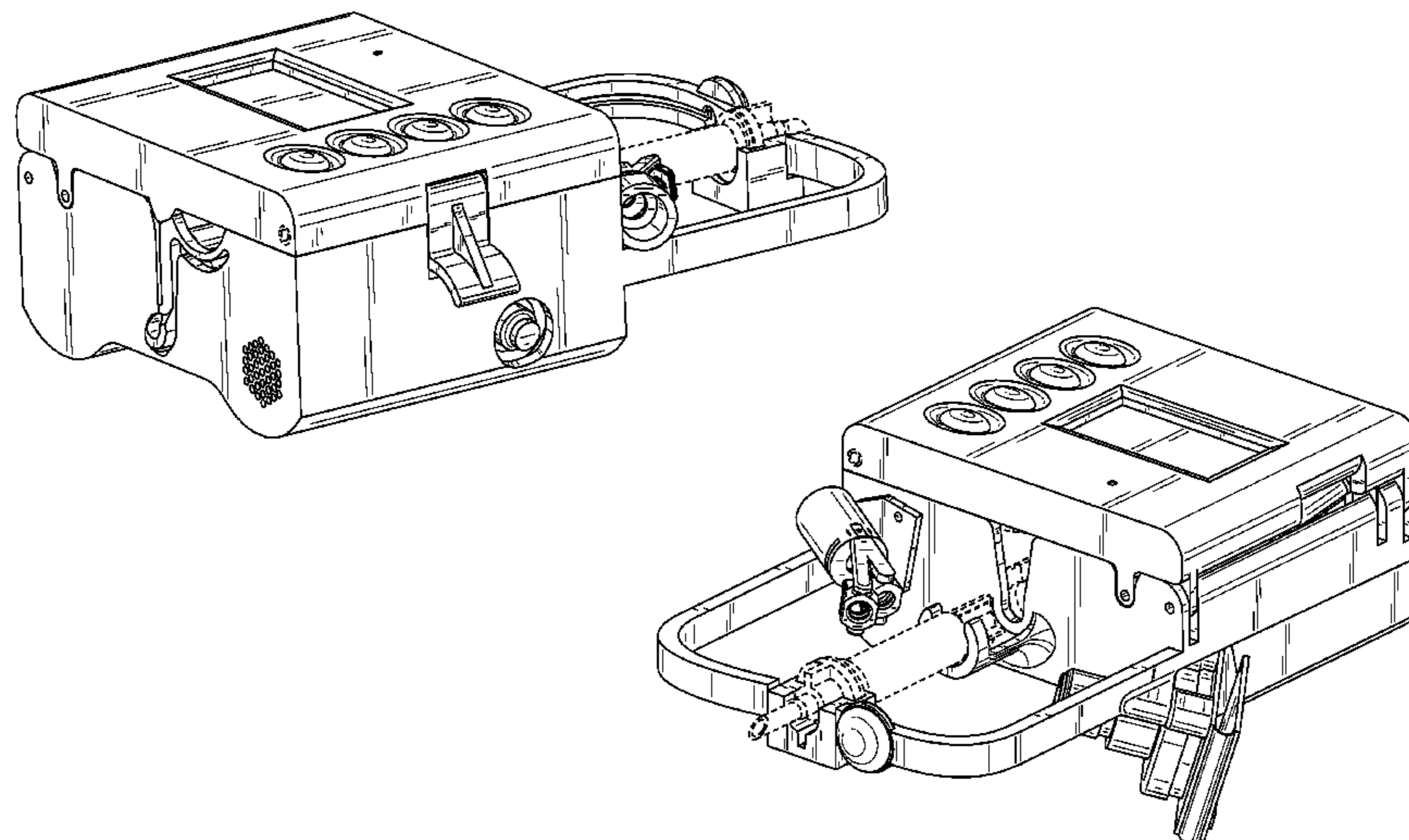

(56)

References Cited

U.S. PATENT DOCUMENTS

2012/0197185	A1	8/2012	Tao	
2012/0238997	A1	9/2012	Dewey	
2012/0265166	A1*	10/2012	Yodfat	A61M 5/1413 604/506
2012/0310153	A1*	12/2012	Moberg	A61M 5/14566 604/67
2013/0035659	A1	2/2013	Hungerford et al.	
2013/0177455	A1	7/2013	Kamen et al.	
2013/0182381	A1	7/2013	Gray et al.	
2013/0184676	A1	7/2013	Kamen et al.	
2013/0188040	A1	7/2013	Kamen et al.	
2013/0191513	A1	7/2013	Kamen et al.	
2013/0197693	A1	8/2013	Kamen et al.	
2013/0201482	A1	8/2013	Munro	
2013/0204188	A1	8/2013	Kamen et al.	
2013/0253442	A1*	9/2013	Travis	A61M 39/28 604/250
2013/0272773	A1	10/2013	Kamen et al.	
2013/0281965	A1	10/2013	Kamen et al.	
2013/0297330	A1	11/2013	Kamen et al.	
2013/0310990	A1	11/2013	Peret et al.	
2013/0317753	A1	11/2013	Kamen et al.	
2013/0317837	A1	11/2013	Ballantyne et al.	
2013/0336814	A1	12/2013	Kamen et al.	
2013/0339049	A1	12/2013	Blumberg, Jr. et al.	
2013/0346108	A1	12/2013	Kamen et al.	
2014/0081233	A1	3/2014	Hungerford et al.	
2014/0135695	A1*	5/2014	Grant	A61M 5/14244 604/111
2014/0148757	A1*	5/2014	Ambrosina	A61M 5/38 604/67
2014/0165703	A1	6/2014	Wilt et al.	
2014/0180711	A1	6/2014	Kamen et al.	
2014/0194818	A1*	7/2014	Yodfat	A61M 5/1413 604/151
2014/0227021	A1	8/2014	Kamen et al.	
2014/0309612	A1*	10/2014	Smisson, III	A61M 1/0281 604/500
2014/0318639	A1	10/2014	Peret et al.	
2015/0002667	A1	1/2015	Peret et al.	
2015/0002668	A1	1/2015	Peret et al.	
2015/0002677	A1	1/2015	Peret et al.	

FOREIGN PATENT DOCUMENTS

DE	2023027	11/1970
DE	3617723 A1	12/1987
DE	3822057 C2	1/1989
DE	69229832 T2	2/2000
EP	0112699 A2	7/1984
EP	1722310 A1	4/2005
EP	2319551 A2	10/2008
FR	2042606 A1	2/1971
FR	2458804	1/1981
FR	2617593	1/1989
GB	1301033 A	12/1972
GB	2020735 A	11/1979
GB	2207239 B	1/1989
GB	2328982 B	3/1999
JP	S58163843	9/1983
JP	3110458 B2	11/2000
JP	2011 062371 A	3/2011
NL	7006908	11/1970
NL	8801680	2/1989
NL	9101825 A	5/1993
SE	376843	6/1975
WO	WO 81/02770 A1	10/1981
WO	WO 93/09407 A1	5/1993
WO	WO 00/72181 A2	11/2000
WO	WO 2004/035116 A1	4/2002
WO	WO 02/40084 A2	5/2002
WO	WO 02/100262 A1	12/2002
WO	WO 2005/094919 A1	10/2005
WO	WO 2006/086723 A2	8/2006

WO	WO 2008/022880 A1	2/2008
WO	WO 2008/079023 A1	7/2008
WO	WO 2009/039203 A2	3/2009
WO	WO 2009/039214 A2	3/2009
WO	WO 2009/055639 A2	4/2009
WO	WO 2010/129720 A2	11/2010
WO	WO 2011/021098 A1	2/2011
WO	WO 2011/136667 A1	11/2011
WO	WO 2013/095459 A9	6/2013
WO	WO 2013/096713 A2	6/2013
WO	WO 2013/096718 A2	6/2013
WO	WO 2013/096722 A2	6/2013

OTHER PUBLICATIONS

Conway, "Analytical Analysis of Tip Travel in a Bourdon Tube", Master's Thesis, Naval Postgraduate School Monterey, Dec. 1995, pp. i-89.

"Principles of Flow Cytometry: An Overview." Methods in Cell Biology: Cytometry. Ed. Zbigniew Darzynkiewicz. 3rd ed. vol. 63. Academic, 2000. 44-48.

"Feature Detection", *OpenCV Wiki*, 2010, 7 pgs, http://opencv.willowgarage.com/documentation/cpp/imgproc_feature_detection.html.

Galambos et al., "Progressive Probabilistic Hough Transform for Line Detection", IEEE, 7 pgs, 1999.

International Search Report & Written Opinion dated May 14, 2012, received in International patent application No. PCT/US2011/066588 (I97WO), 9 pgs.

International Search Report & Written Opinion dated Jun. 18, 2013, received in International patent application No. PCT/US2012/071142 (J79WO), 14 pgs.

International Search Report & Written Opinion dated Oct. 1, 2013, received in International patent application No. PCT/US2012/071490 (J76WO), 19 pgs.

International Search Report & Written Opinion dated Dec. 4, 2013, received in International patent application No. PCT/US2013/032445 (K14WO), 20 pgs.

International Search Report & Written Opinion dated Nov. 7, 2013, received in International patent application No. PCT/US2013/042350 (K66WO), 18 pgs.

Invitation to Pay Additional Fees and, Where Applicable, Protest Fee dated Sep. 9, 2013, received in International patent application No. PCT/U52013/032445 (K14WO), 10 pgs.

Invitation to Pay Additional Fees and, Where Applicable, Protest Fee dated Sep. 26, 2013, received in International patent application No. PCT/US2013/042350 (K66WO), 7 pgs.

Hofmann, "Modeling Medical Devices for Plug-and-Play Interoperability", MIT Department of Electrical Engineering and Computer Science, Jun. 2007, pp. 1-187.

King et al. *Prototyping closed loop physiologic control with the medical device coordination framework*. In SEHC 2010: *Proceedings of the 2010 ICSE Workshop on Software Engineering in Health Care* (pp. 1-11). New York, NY: ACM. (2010).

Jetley et al., "Safety Requirements Based Analysis of Infusion Pump Software", Proceedings of the IEEE Real Time Systems Symposium, Tuscon, Dec. 2007 pp. 1-4.

FDA US Food and Drug Administration, "SEDASYS® Computer-Assisted Personalized Sedation System—P08000", Jul. 16, 2013, pp. 1-2, www.fda.gov/MedicalDevices/ProductsandMedicalProcedures/DeviceApprovalsandClearances/Recently-ApprovedDevices/ucm353950.htm.

Luerkens, David W. "Theory and Application of Morphological Analysis: Fine Particles and Surfaces". Boca Raton: CRC, 1991. 5-7.

Matas et al., *Progressive Probabilistic Hough Transform*. "Miscellaneous Image Transformations", *OpenCV Wiki*, 2011, 9 pgs., http://opencv.willowgarage.com/documentation/cpp/miscellaneous_image_transformations.

National Patient Safety Agency, *Design for Patient Safety: A Guide to the Design of Electronic Infusion Devices*, booklet, 2010, pp. 1-96, Edition 1, National Patient Safety Agency, London.

"Object Detection", *OpenCV Wiki*, 2011, 2 pgs., http://opencv.willowgarage.com/documentation/cpp/object_detection.html.

(56)

References Cited

OTHER PUBLICATIONS

"The OpenCV Reference Manual Release 2.4.6.0", Jul. 1, 2013, pp. 1-813.

Leor et al., *"A System for the Measurement of Drop Volume of Intravenous Solutions"*, Proceedings Computers in Cardiology 1990, pp. 405-406, Los Alamitos, California.

Butterfield, *"Alaris SE Pump, Monitoring and Detection of IV Line Occlusions."*, CareFusion Corporation, 2010, 4 pgs.

"Vista Basic: Instructions for Use: Software IFVB", manual, 2002, pp. 3, B. Braun Medical Inc.

Hugli et al., *"Drop volume measurement by vision."* Proceedings of SPIE Electronic Imaging Conference, San Diego, Jan. 2000. SPIE vol. 3866-11, pp. 60-66.

* cited by examiner

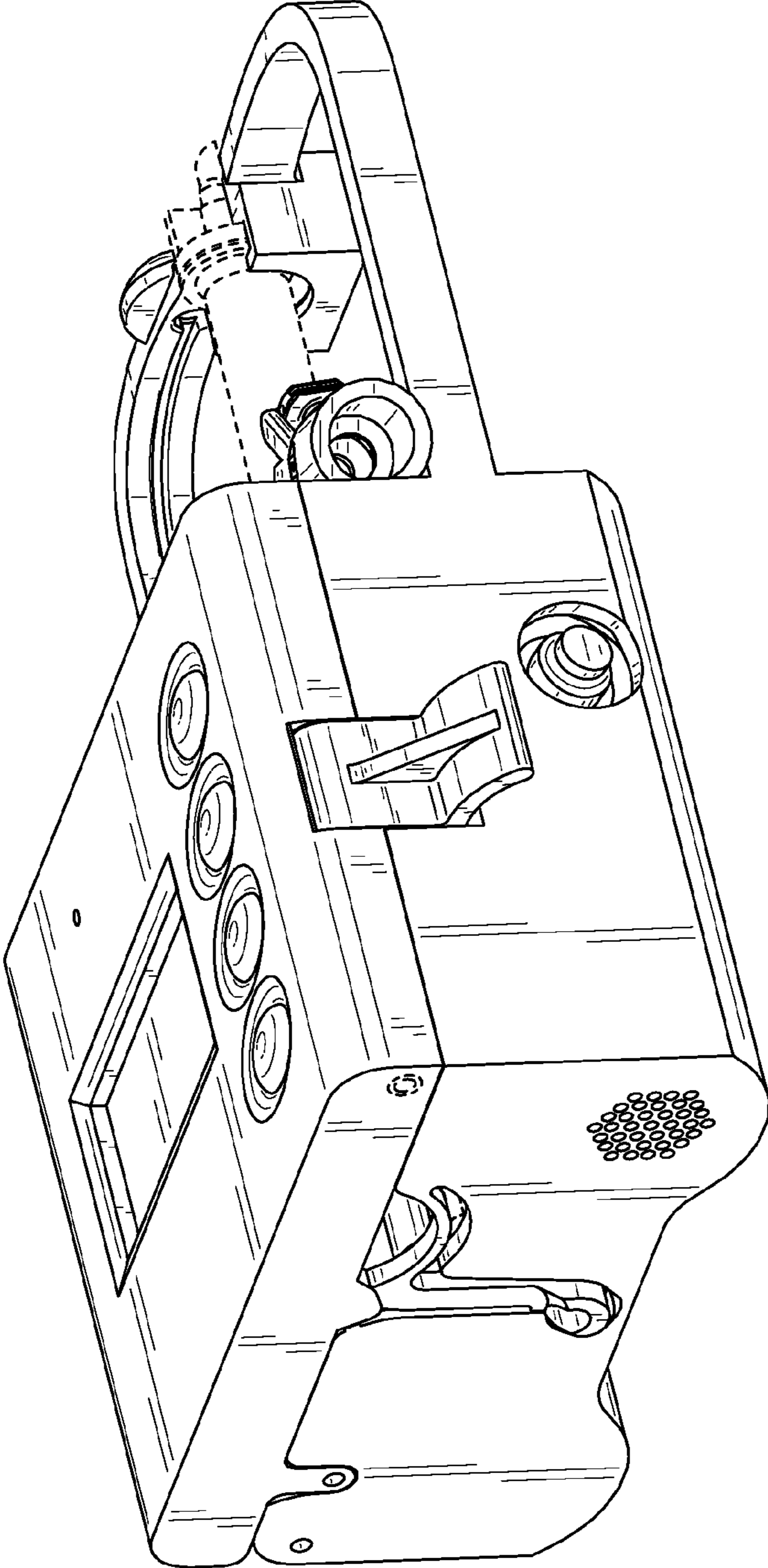

FIG. 1

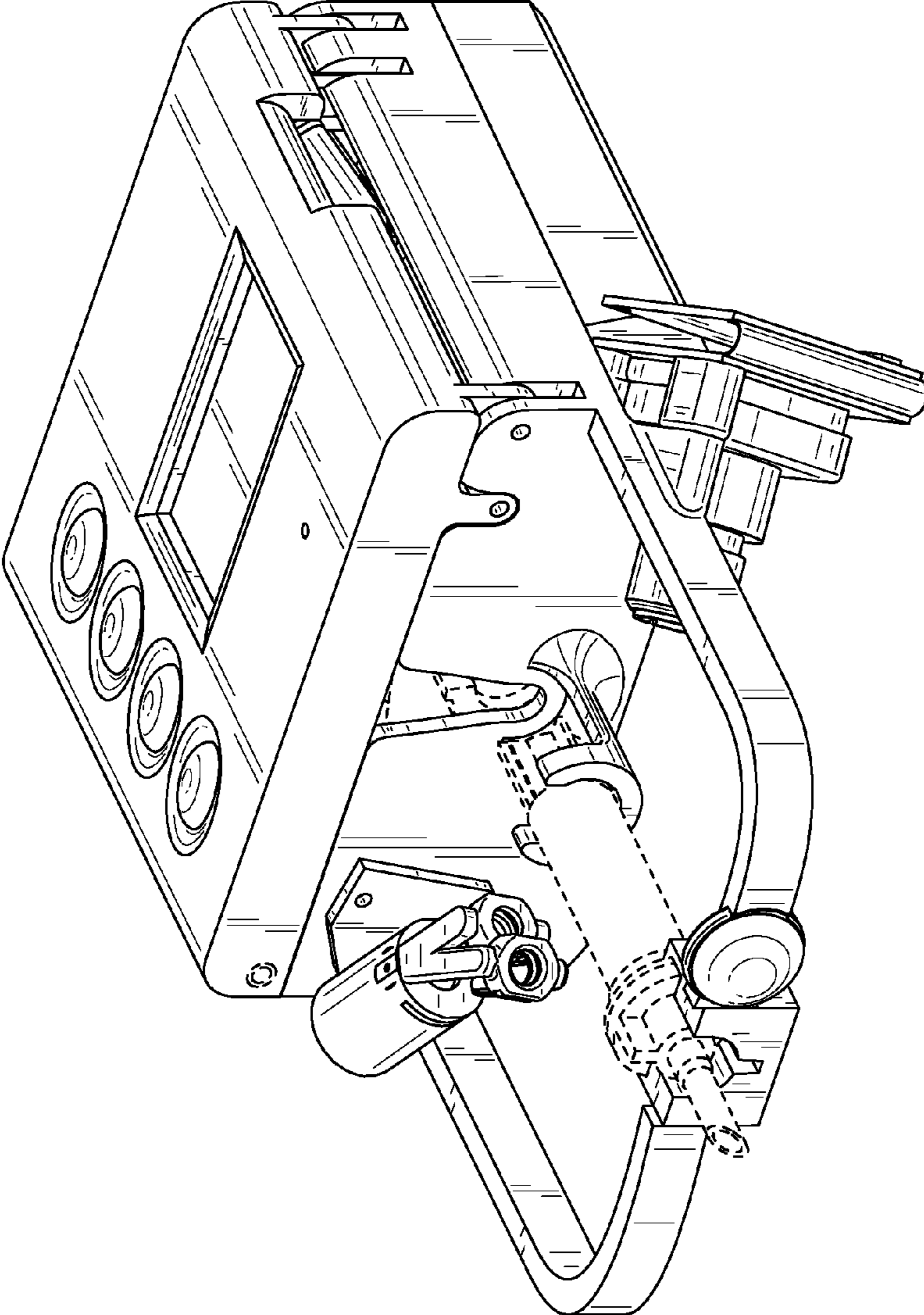

FIG. 2

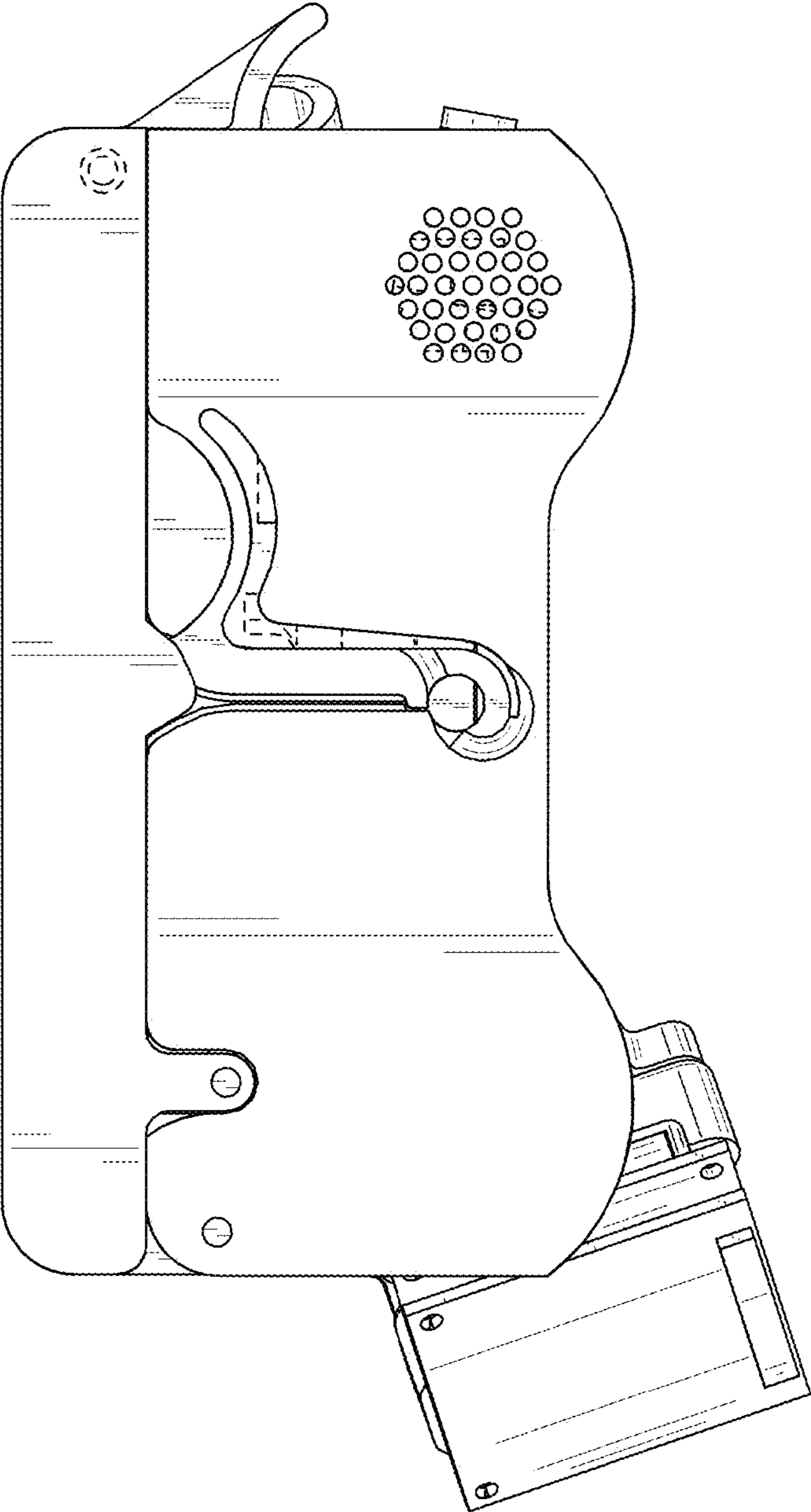

FIG. 3

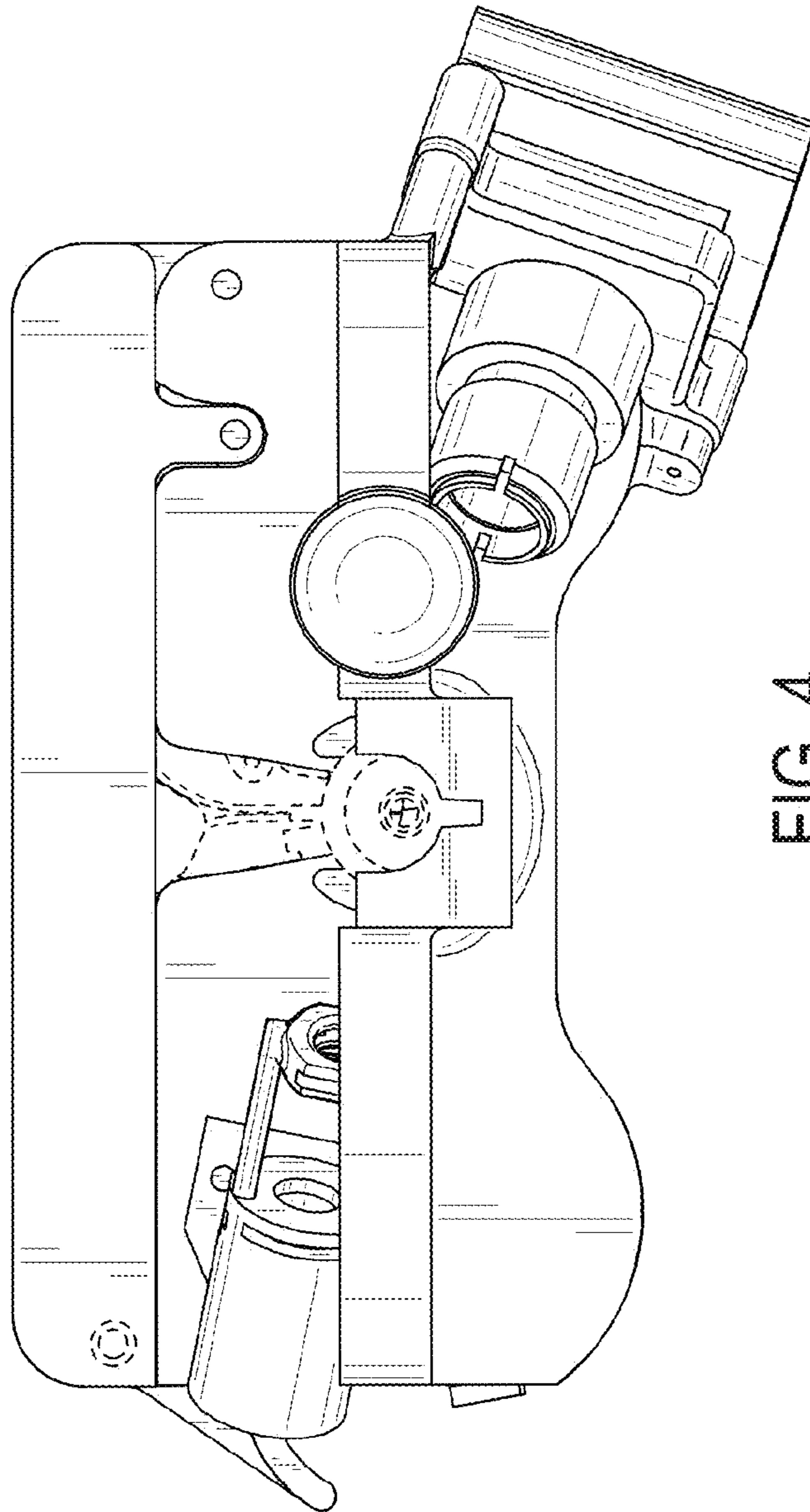

FIG. 4

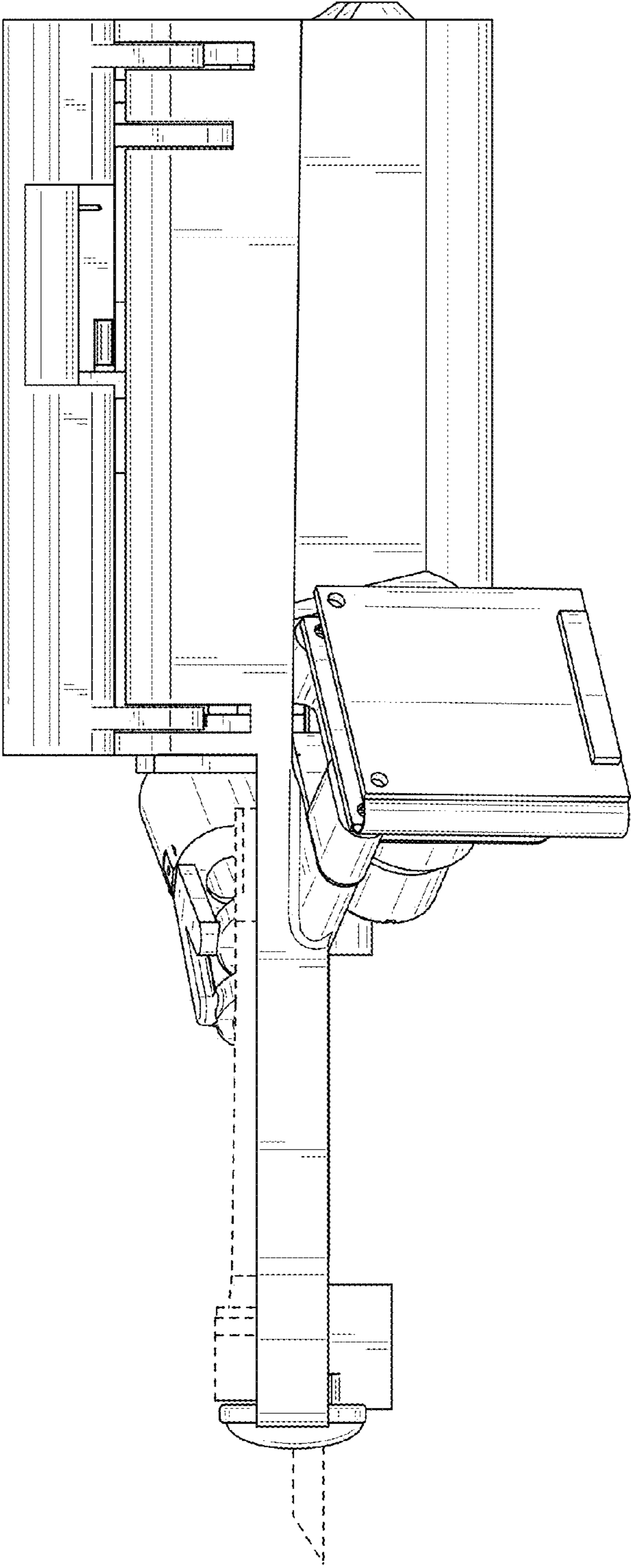

FIG. 5

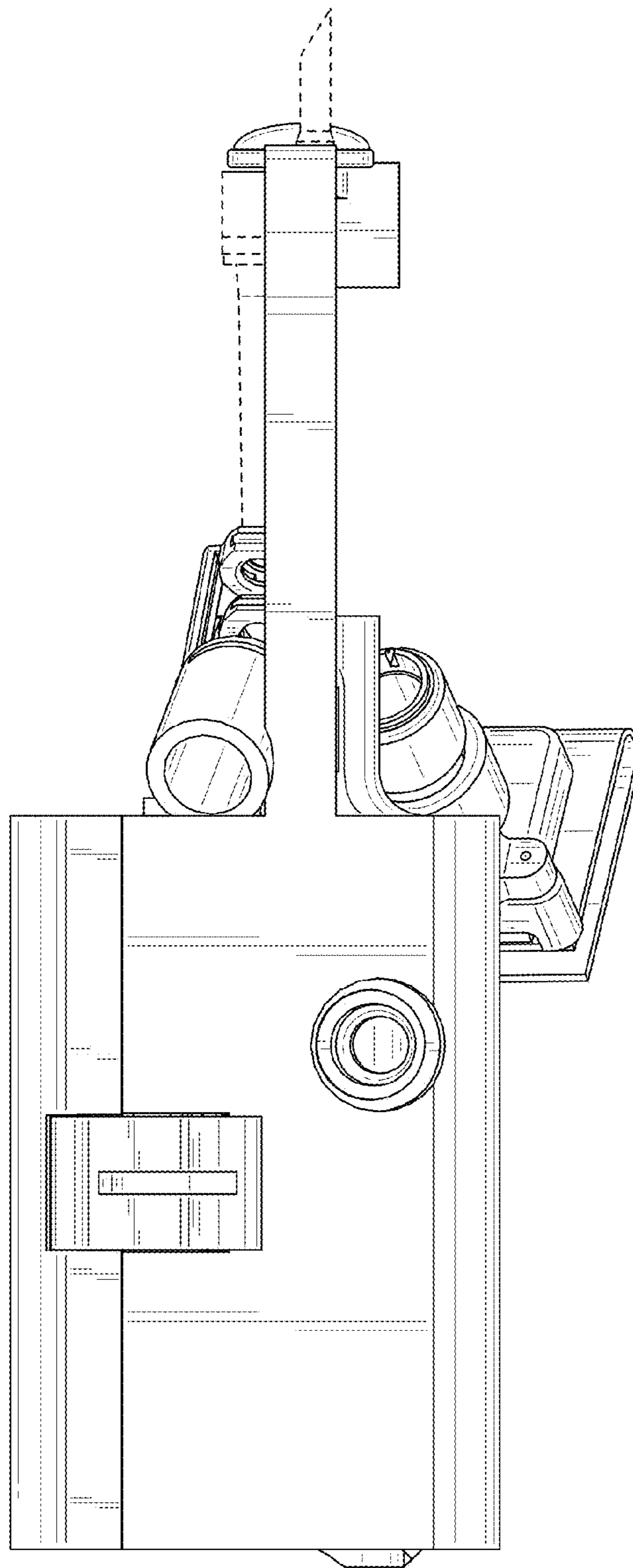

FIG. 6

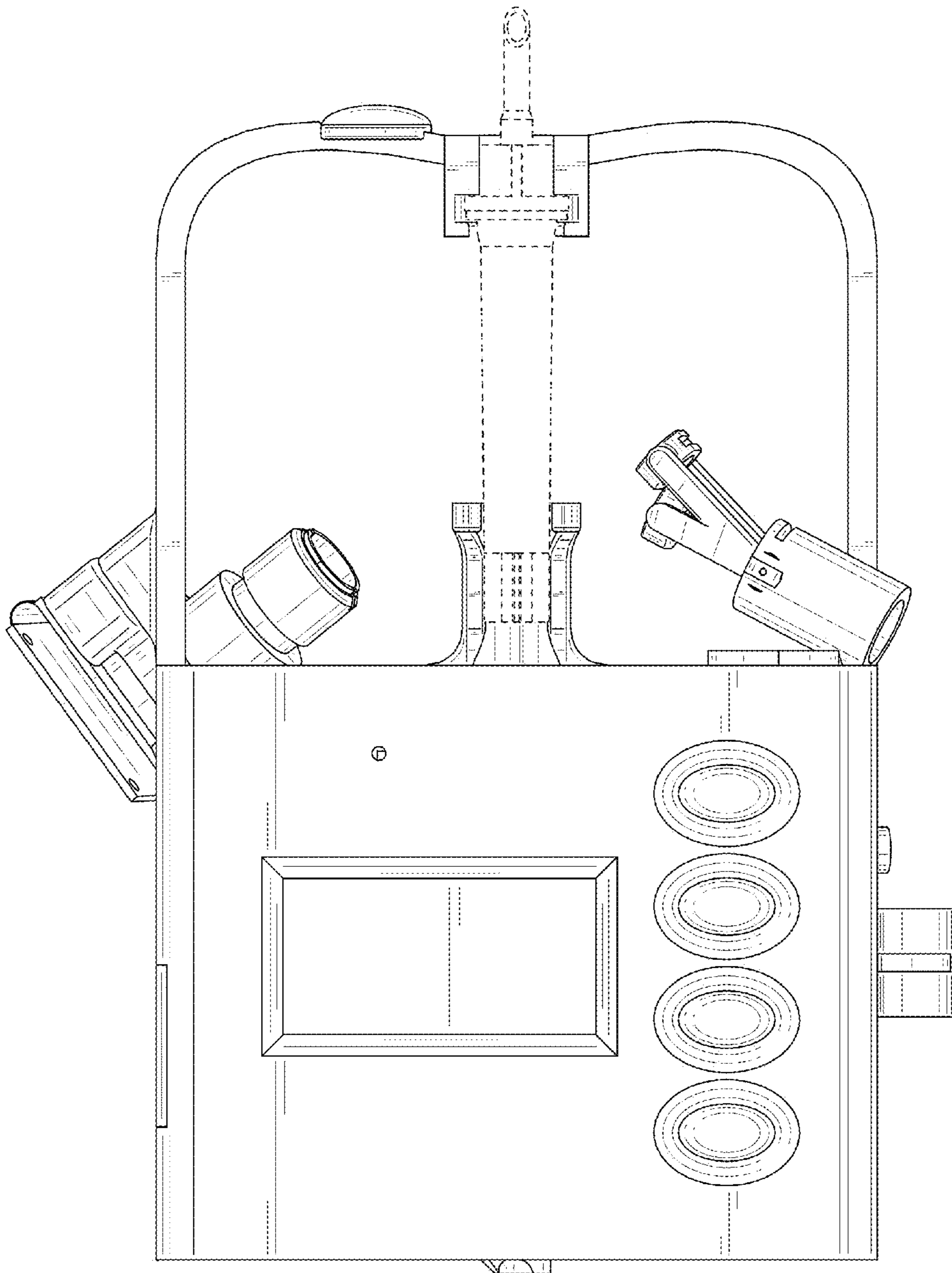

FIG. 7

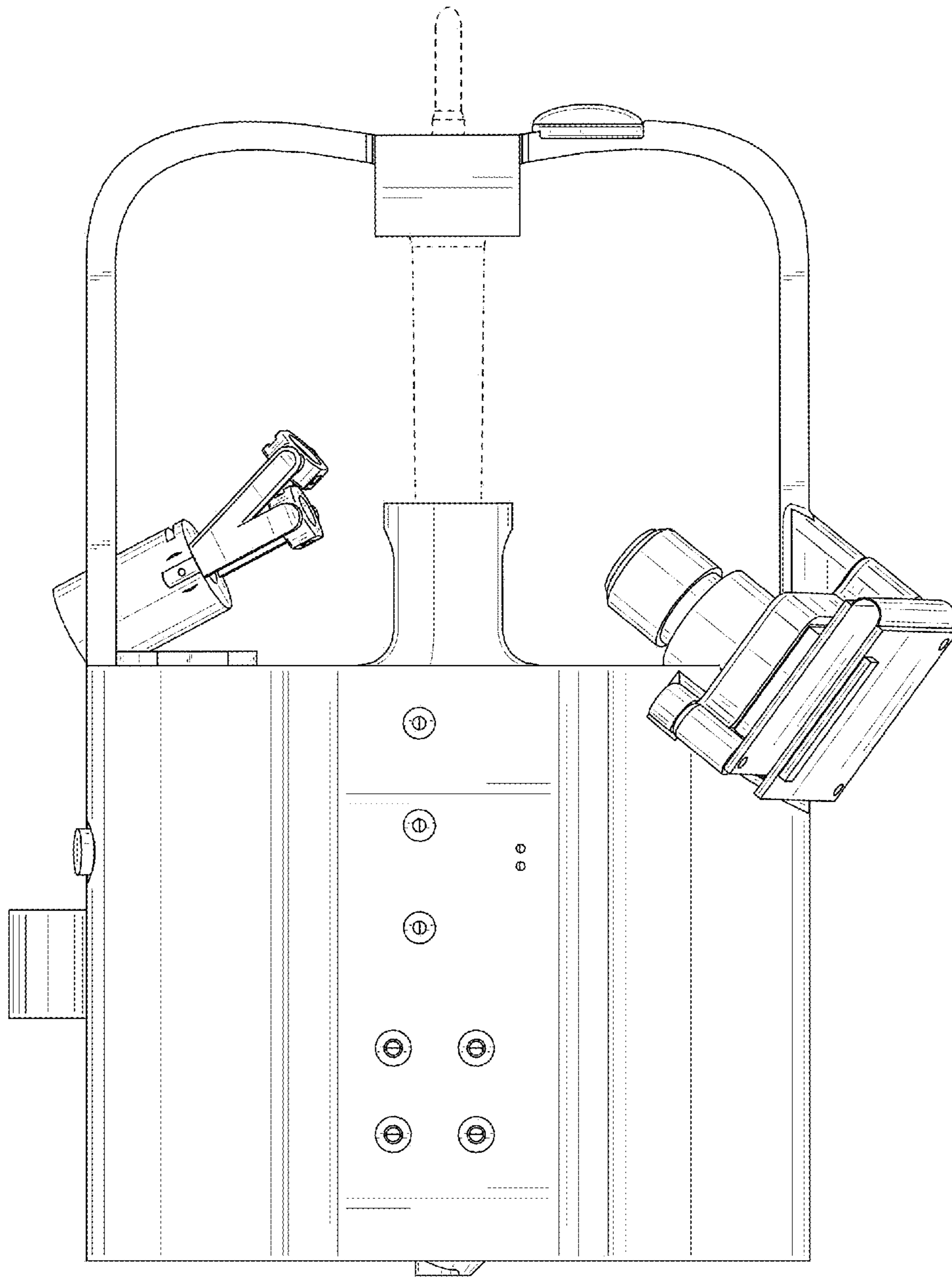

Fig. 8