



US00D751676S

(12) **United States Design Patent**
Frick et al.

(10) **Patent No.:** **US D751,676 S**
(45) **Date of Patent:** **** Mar. 15, 2016**

(54) **QUICK CONNECT COUPLING HOUSING**

(71) Applicant: **Moen Incorporated**, North Olmsted, OH (US)

(72) Inventors: **Timothy A. Frick**, Brunswick, OH (US);
W. Randall Tucker, Oberlin, OH (US)

(73) Assignee: **Moen Incorporated**, North Olmsted, OH (US)

(**) Term: **14 Years**

(21) Appl. No.: **29/490,893**

(22) Filed: **May 15, 2014**

Related U.S. Application Data

(63) Continuation of application No. 13/468,515, filed on May 10, 2012, now Pat. No. 8,764,068.

(51) **LOC (10) Cl.** **23-01**

(52) **U.S. Cl.**
USPC **D23/262**

(58) **Field of Classification Search**

USPC D8/382, 14, 349, 354, 383, 394, 395,
D8/499; D23/200, 259, 260, 262, 265,
D23/266, 249, 206, 303, 304, 386, 499
CPC ... F16L 37/0841; F16L 37/0845; F16L 37/62;
F16L 37/08; F16L 37/0842; F16L 55/00;
E03C 1/0403; Y10S 285/921
See application file for complete search history.

(56) **References Cited**

U.S. PATENT DOCUMENTS

2,946,546 A * 7/1960 Pokorny et al. 248/534
3,383,124 A 5/1968 Wickens

(Continued)

OTHER PUBLICATIONS

International Search Report for International App. No. PCT/US2013/040079 dated Sep. 6, 2013 (3 pages).

(Continued)

Primary Examiner — Sheryl Lane

Assistant Examiner — Ieisha Price

(74) *Attorney, Agent, or Firm* — Calfee, Halter & Griswold LLP

(57) **CLAIM**

The ornamental design for a quick connect coupling housing, as shown and described.

DESCRIPTION

FIG. 1 is a perspective view of a first embodiment of a quick connect coupling housing of the new design;
FIG. 2 is a front elevational view of the quick connect coupling housing of FIG. 1, the rear elevational view being a mirror image thereof;
FIG. 3 is a left side elevational view of the quick connect coupling housing of FIG. 1;
FIG. 4 is a right side elevational view of the quick connect coupling housing of FIG. 1;
FIG. 5 is a top plan view of the quick connect coupling housing of FIG. 1;
FIG. 6 is a perspective view of a second embodiment of a quick connect coupling housing of the new design;
FIG. 7 is a front elevational view of the quick connect coupling housing of FIG. 6, the rear elevational view being a mirror image thereof;
FIG. 8 is a left side elevational view of the quick connect coupling housing of FIG. 6;
FIG. 9 is a right side elevational view of the quick connect coupling housing of FIG. 6;
FIG. 10 is a top plan view of the quick connect coupling housing of FIG. 6;
FIG. 11 is a perspective view of a third embodiment of a quick connect coupling housing of the new design;
FIG. 12 is a front elevational view of the quick connect coupling housing of FIG. 11, the rear elevational view being a mirror image thereof;
FIG. 13 is a left side elevational view of the quick connect coupling housing of FIG. 11;
FIG. 14 is a right side elevational view of the quick connect coupling housing of FIG. 11; and,
FIG. 15 is a top plan view of the quick connect coupling housing of FIG. 11.

The broken lines in the drawings illustrate portions of the quick connect coupling housing and form no part of the claimed design.

1 Claim, 13 Drawing Sheets

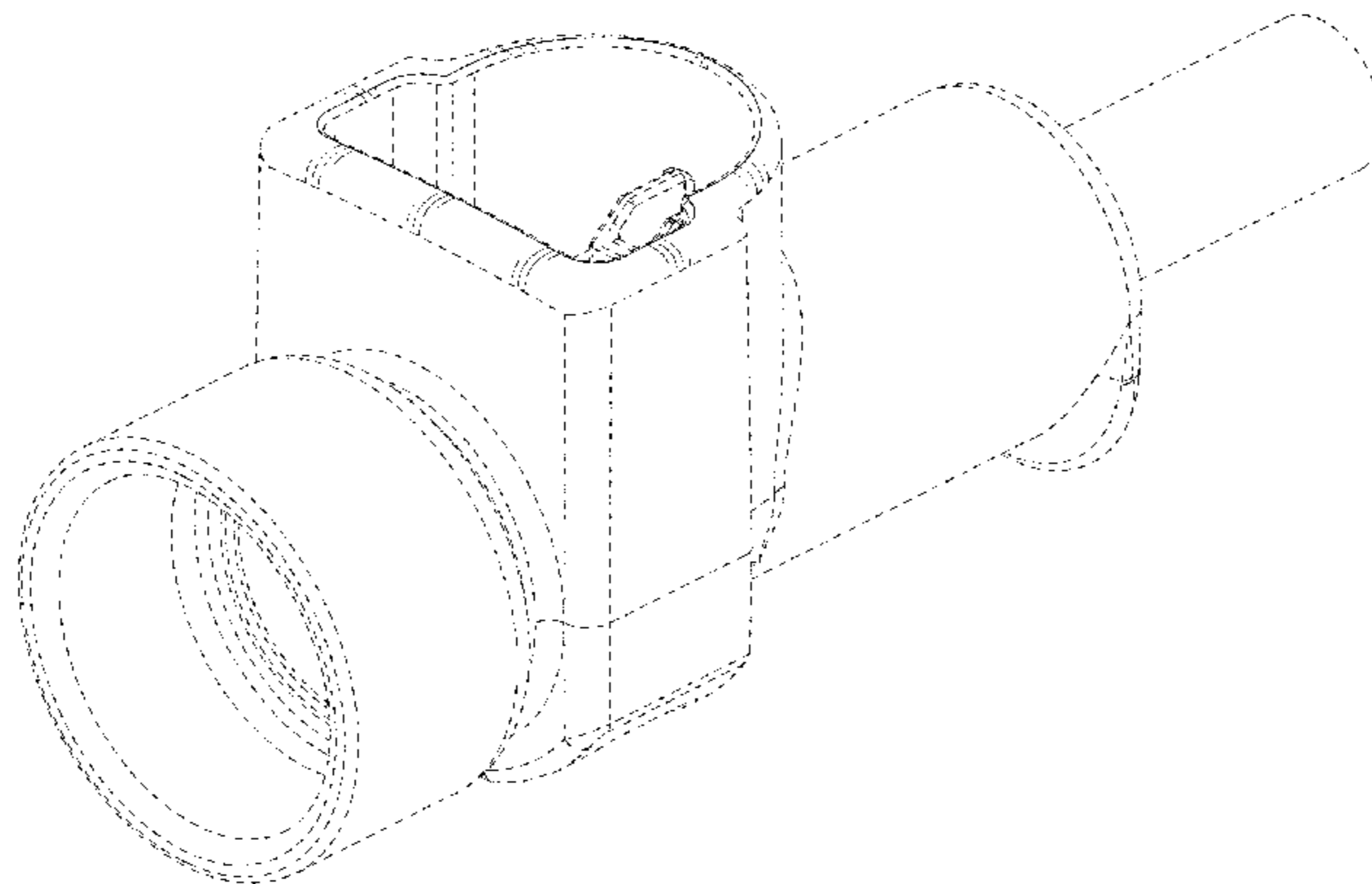

(56)

References Cited

U.S. PATENT DOCUMENTS

3,948,548 A 4/1976 Voss
 4,244,608 A 1/1981 Stuemky
 4,423,892 A 1/1984 Bartholomew
 4,436,125 A 3/1984 Blenkush
 4,500,118 A 2/1985 Blenkush
 4,541,457 A 9/1985 Blenkush
 4,591,192 A 5/1986 Van Exel et al.
 4,630,847 A 12/1986 Blenkush
 4,664,427 A 5/1987 Johnston
 4,703,957 A 11/1987 Blenkush
 4,903,995 A 2/1990 Blenkush et al.
 4,934,655 A 6/1990 Blenkush et al.
 4,946,200 A 8/1990 Blenkush et al.
 4,969,879 A 11/1990 Lichte
 5,033,777 A 7/1991 Blenkush
 5,052,725 A 10/1991 Meyer et al.
 5,064,227 A 11/1991 Spors et al.
 5,074,601 A * 12/1991 Spors et al. 285/308
 5,102,313 A 4/1992 Szabo
 5,104,158 A 4/1992 Meyer et al.
 5,178,303 A 1/1993 Blenkush et al.
 5,316,041 A 5/1994 Ramacier, Jr. et al.
 5,353,836 A 10/1994 deCler et al.
 D357,307 S * 4/1995 Ramacier et al. D23/262
 5,452,924 A 9/1995 Kujawski
 5,494,074 A 2/1996 Ramacier, Jr. et al.
 5,542,716 A 8/1996 Szabo et al.
 5,586,792 A 12/1996 Kalahasthy et al.
 5,639,064 A 6/1997 deCler et al.
 D384,731 S * 10/1997 Ramacier et al. D23/262
 D384,911 S * 10/1997 Stroud D11/218
 5,683,117 A 11/1997 Corbett et al.
 5,730,481 A 3/1998 Szabo et al.
 5,758,909 A 6/1998 Dole et al.
 5,782,502 A 7/1998 Lewis
 5,845,943 A 12/1998 Ramacier, Jr. et al.
 5,863,077 A 1/1999 Szabo et al.
 5,897,142 A 4/1999 Kulevsky
 5,911,403 A 6/1999 deCler et al.
 5,931,510 A 8/1999 Mathew et al.
 5,938,244 A 8/1999 Meyer
 5,951,063 A 9/1999 Szabo
 5,975,489 A 11/1999 deCler et al.
 6,024,124 A 2/2000 Braun et al.
 6,082,401 A 7/2000 Braun et al.
 6,129,393 A 10/2000 Kodama et al.
 6,161,578 A 12/2000 Braun et al.
 6,231,089 B1 5/2001 DeCler et al.
 6,293,596 B1 9/2001 Kinder
 6,382,593 B1 5/2002 deCler et al.
 6,431,612 B1 8/2002 Walker et al.
 6,550,815 B2 4/2003 Zitkowic, Jr. et al.
 6,557,903 B2 5/2003 Walker
 6,626,419 B2 9/2003 deCler et al.
 6,634,679 B1 10/2003 Stieler
 6,637,779 B2 10/2003 Andre
 6,649,829 B2 11/2003 Garber et al.
 6,705,591 B2 3/2004 deCler
 6,802,491 B1 10/2004 Kelly et al.
 6,805,383 B2 10/2004 Ostrander et al.
 6,848,602 B2 2/2005 deCler et al.
 6,869,110 B2 3/2005 Okada et al.

6,871,669 B2 3/2005 Meyer et al.
 6,897,374 B2 5/2005 Garber et al.
 D506,668 S * 6/2005 Black D8/354
 6,902,144 B2 6/2005 deCler
 6,905,143 B2 6/2005 Klinger et al.
 D507,475 S * 7/2005 Phillips et al. D8/349
 6,916,007 B2 7/2005 deCler et al.
 6,962,275 B2 11/2005 deCler et al.
 6,978,800 B2 12/2005 deCler et al.
 D523,803 S * 6/2006 Smith et al. D12/223
 7,080,665 B2 7/2006 Whall
 7,163,022 B2 1/2007 Whall
 7,314,209 B2 1/2008 Pierson
 7,316,425 B2 1/2008 Poder
 7,316,428 B2 1/2008 Takayanagi et al.
 7,328,922 B2 2/2008 Takayanagi et al.
 7,338,086 B2 * 3/2008 Poder et al. 285/81
 7,390,025 B2 6/2008 Pepe et al.
 7,394,375 B2 7/2008 Johnson
 7,402,063 B2 7/2008 Montena
 7,434,842 B2 10/2008 Schmidt
 7,434,847 B2 10/2008 Densel et al.
 7,469,472 B2 12/2008 deCler et al.
 7,484,774 B2 2/2009 Kerin et al.
 7,488,446 B2 2/2009 Meyer et al.
 7,537,247 B2 5/2009 Trede et al.
 7,546,857 B2 6/2009 Chadbourne et al.
 7,547,047 B2 6/2009 deCler et al.
 7,562,906 B2 7/2009 Schmidt
 D602,128 S 10/2009 Williams et al.
 7,631,660 B2 12/2009 deCler et al.
 7,647,954 B2 1/2010 Garber et al.
 D612,019 S 3/2010 Williams et al.
 D612,021 S 3/2010 Schmidt
 7,677,608 B2 * 3/2010 Takayanagi 285/319
 7,695,020 B2 * 4/2010 Schmidt 285/91
 7,695,024 B2 4/2010 Ostergren et al.
 7,708,025 B2 5/2010 Johnson
 7,802,822 B2 9/2010 Poder et al.
 7,841,357 B2 11/2010 Rankin
 D633,988 S * 3/2011 Ball et al. D23/259
 7,954,374 B2 6/2011 Rankin
 7,954,515 B2 6/2011 Gerst
 D654,573 S * 2/2012 Lombardi et al. D23/262
 D687,270 S * 8/2013 Olson et al. D8/8
 D702,529 S * 4/2014 Diez Herrera D8/349
 9,046,205 B2 * 6/2015 Whitaker et al.
 2005/0057042 A1 3/2005 Wicks
 2005/0189764 A1 9/2005 Ono
 2005/0236833 A1 10/2005 Poirier et al.
 2006/0082145 A1 4/2006 Steveley
 2006/0207345 A1 9/2006 Rankin
 2007/0025811 A1 2/2007 Wilhelm
 2007/0126232 A1 6/2007 Campagna et al.
 2007/0232155 A1 10/2007 Frey
 2009/0177186 A1 7/2009 Delano
 2009/0188575 A1 7/2009 Williams et al.
 2010/0089475 A1 4/2010 Tracey
 2014/0300100 A1 * 10/2014 Frick et al. 285/105

OTHER PUBLICATIONS

Written Opinion of the International Searching Authority for International App. No. PCT/US2013/040079 dated Sep. 6, 2013 (6 pages).

* cited by examiner

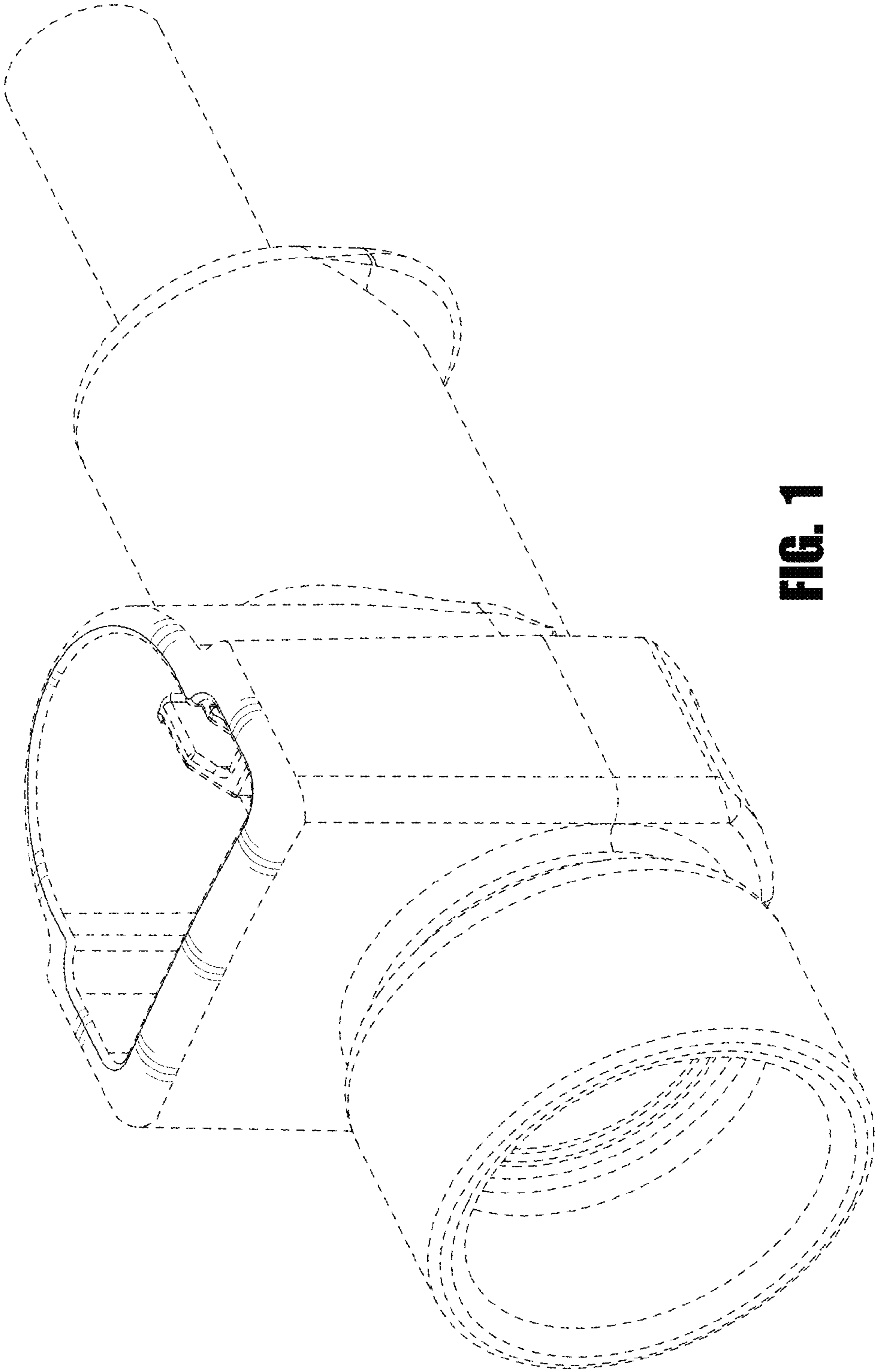

FIG. 1

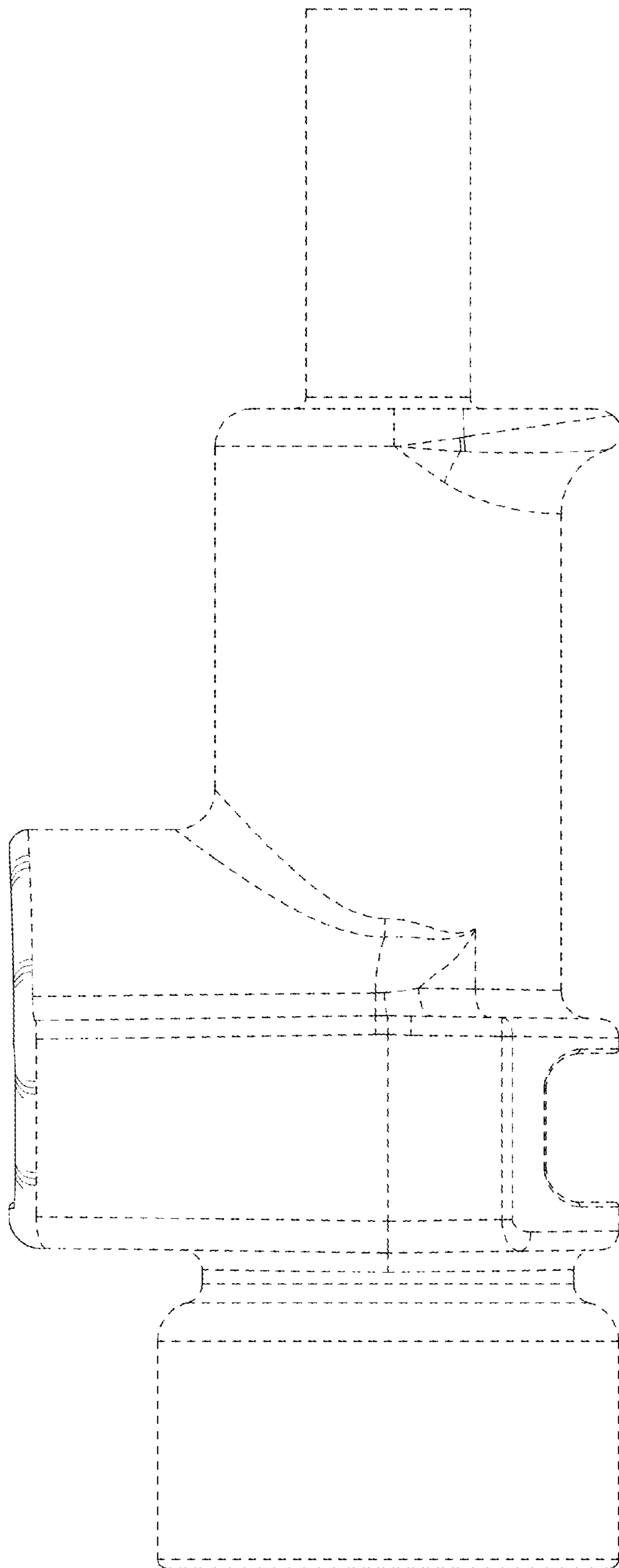

FIG. 2

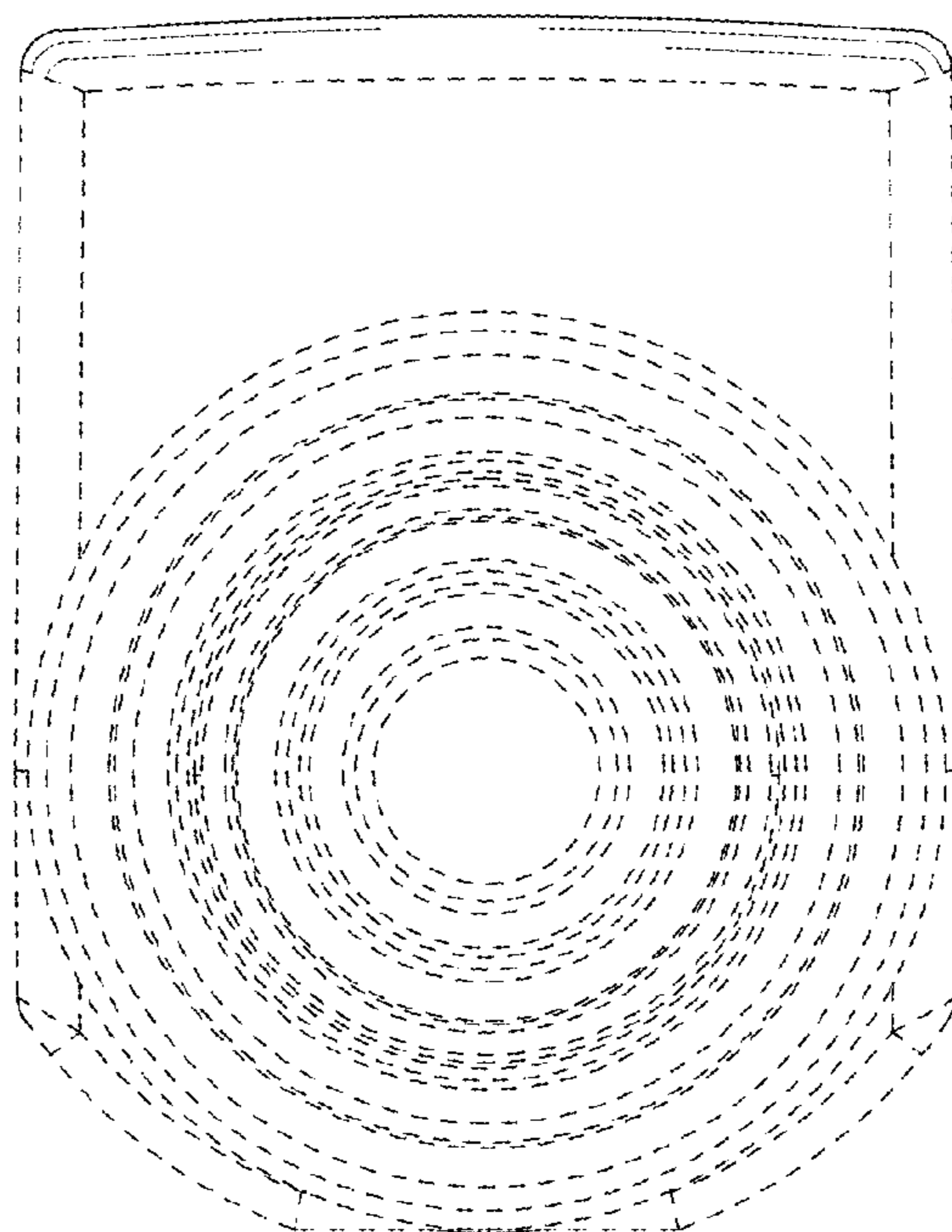

FIG. 3

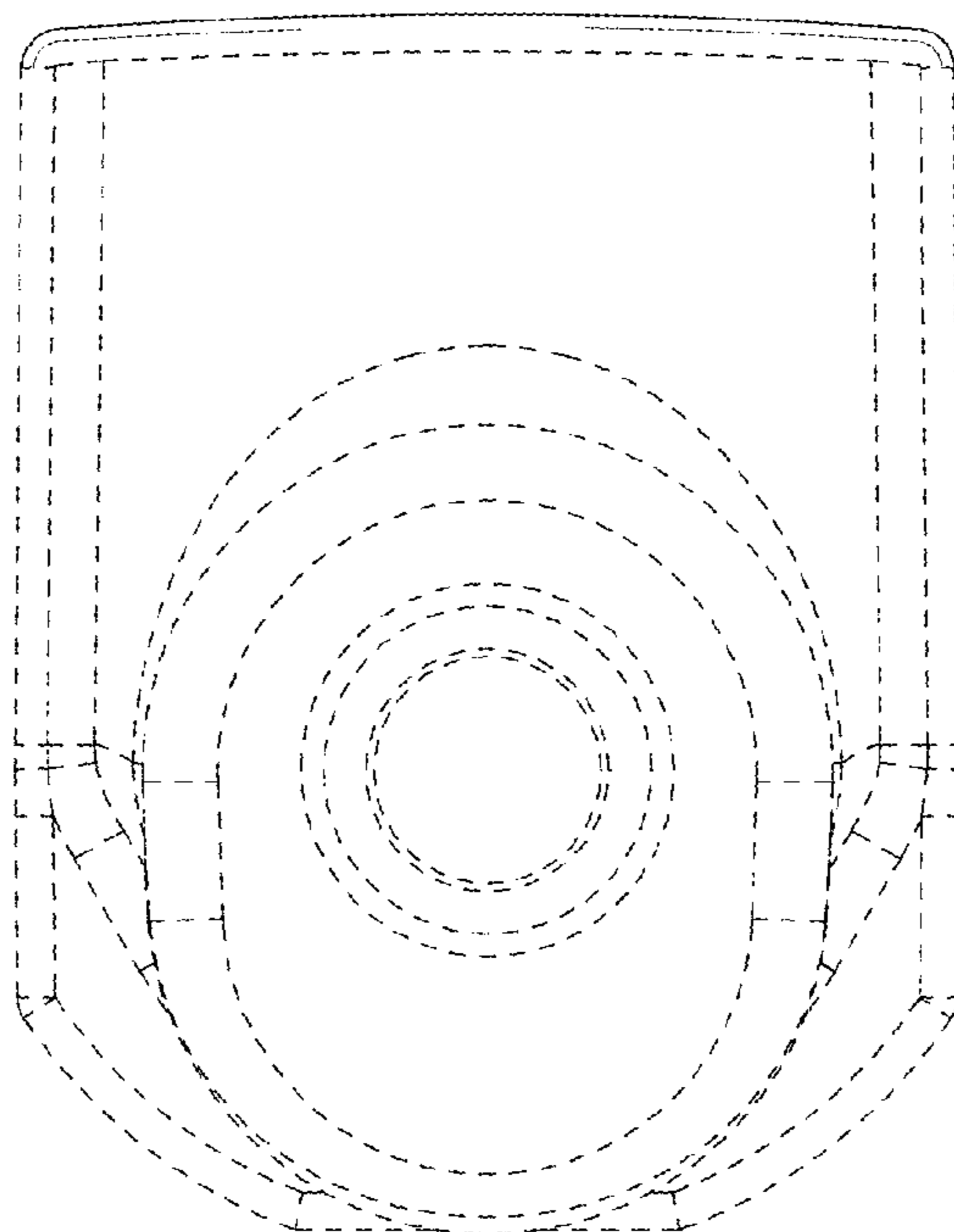

FIG. 4

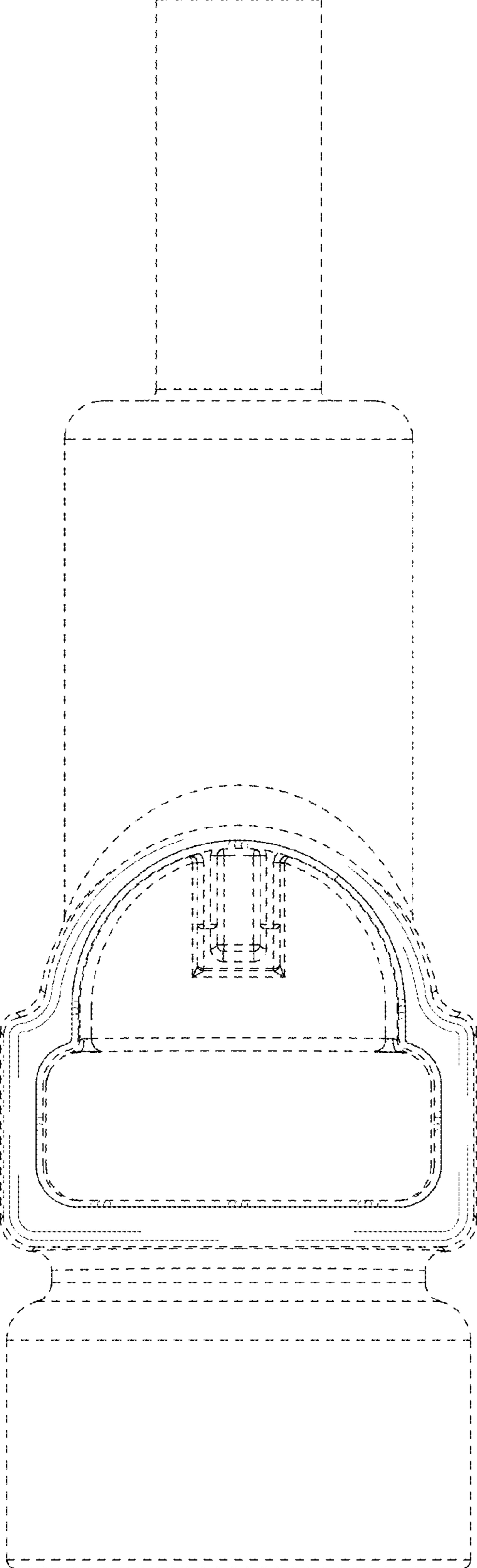

FIG. 5

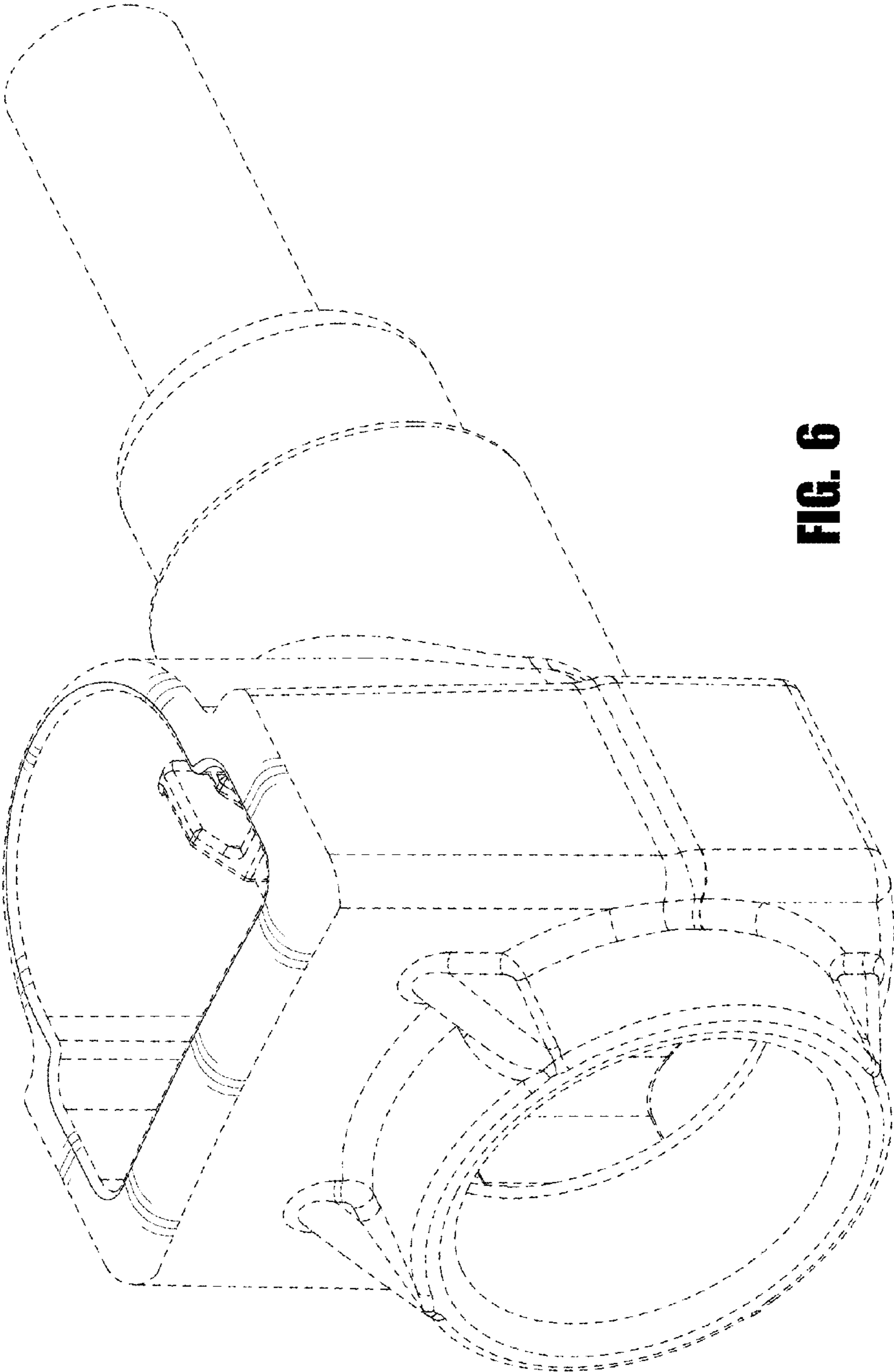

FIG. 6

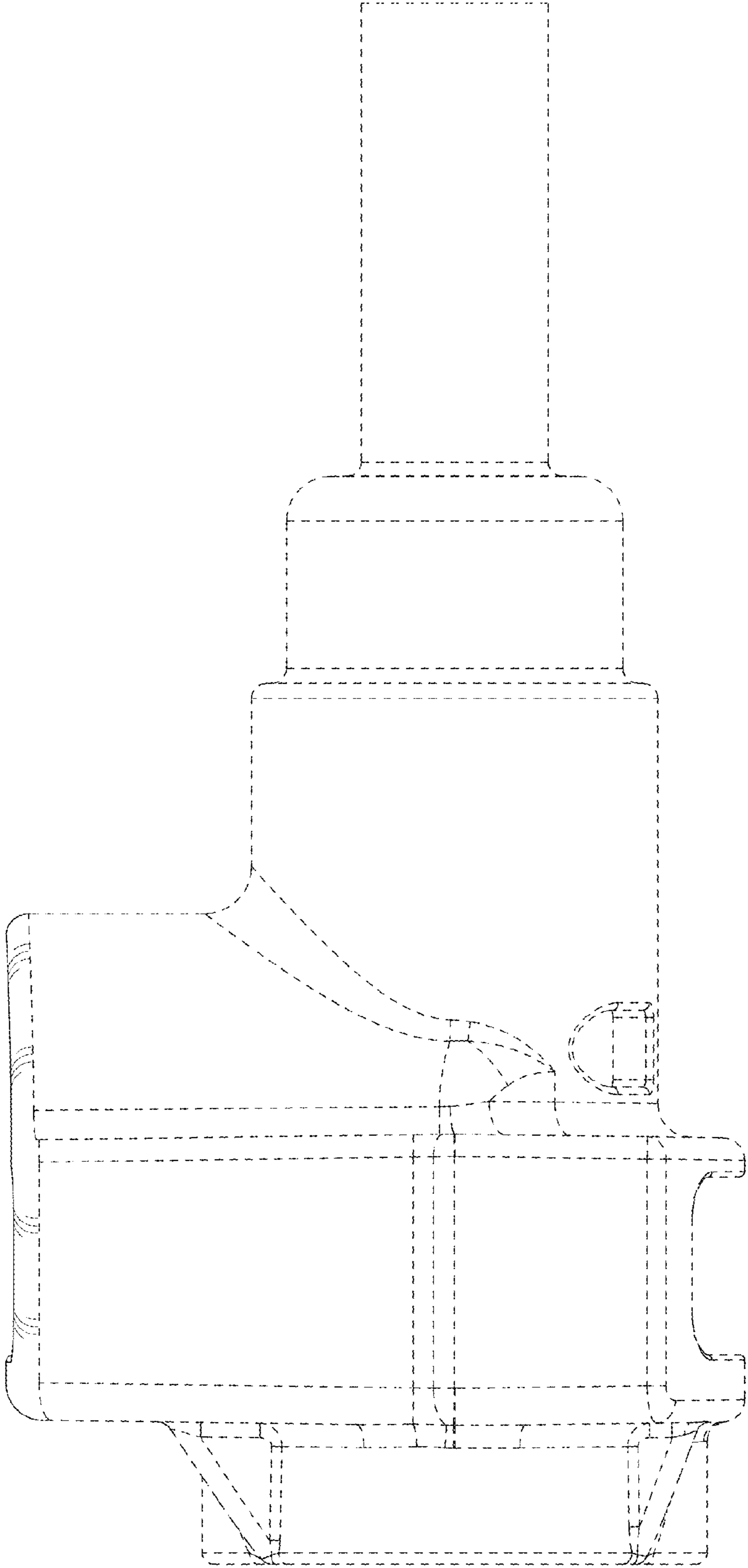

FIG. 7

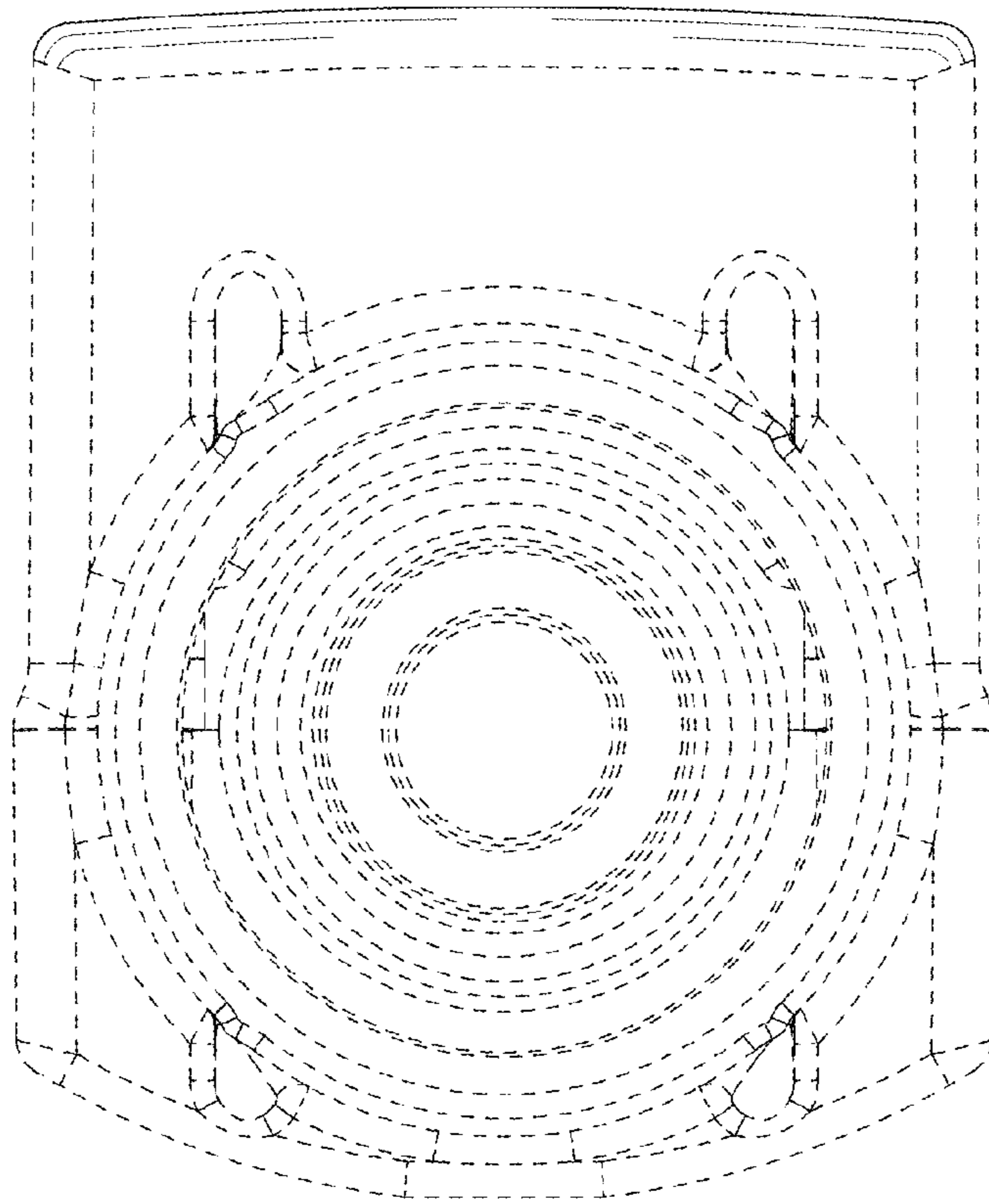

FIG. 8

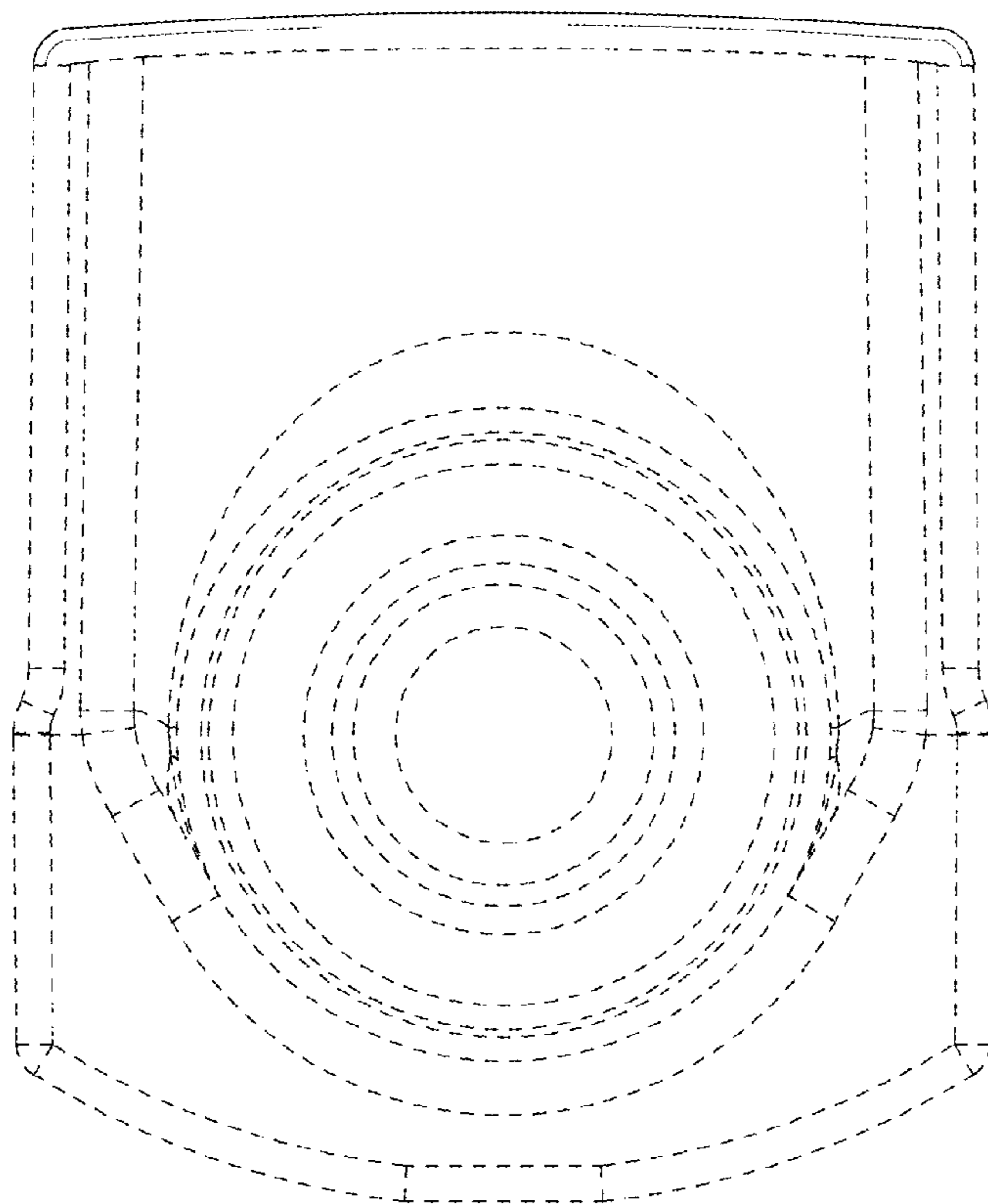

FIG. 9

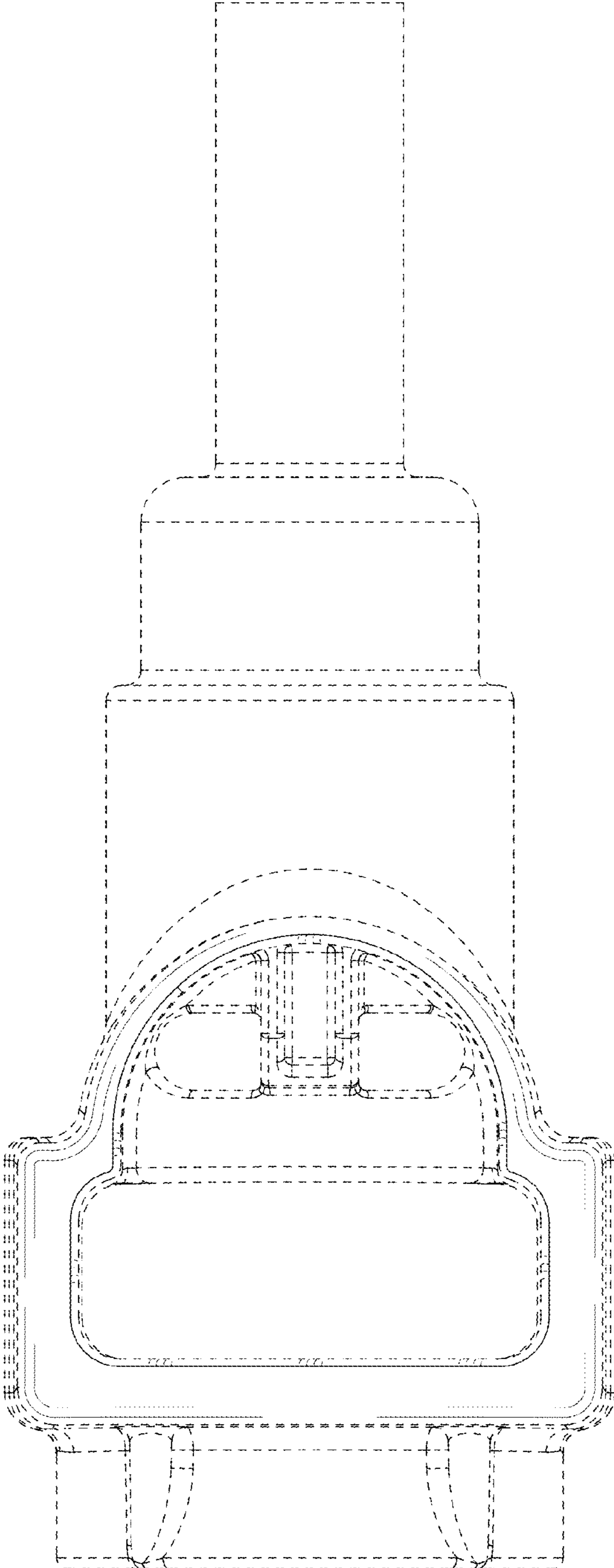

FIG. 10

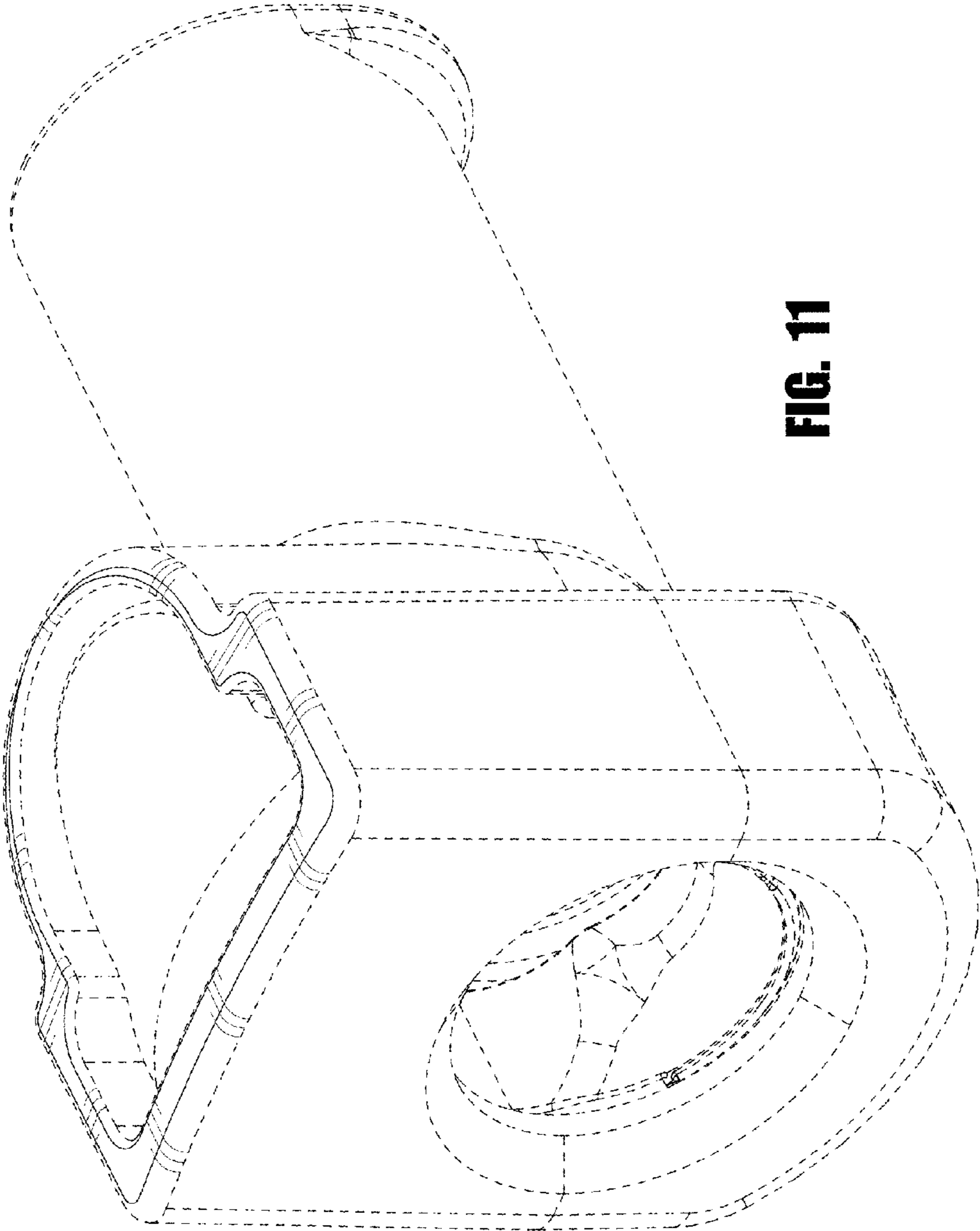

FIG. 11

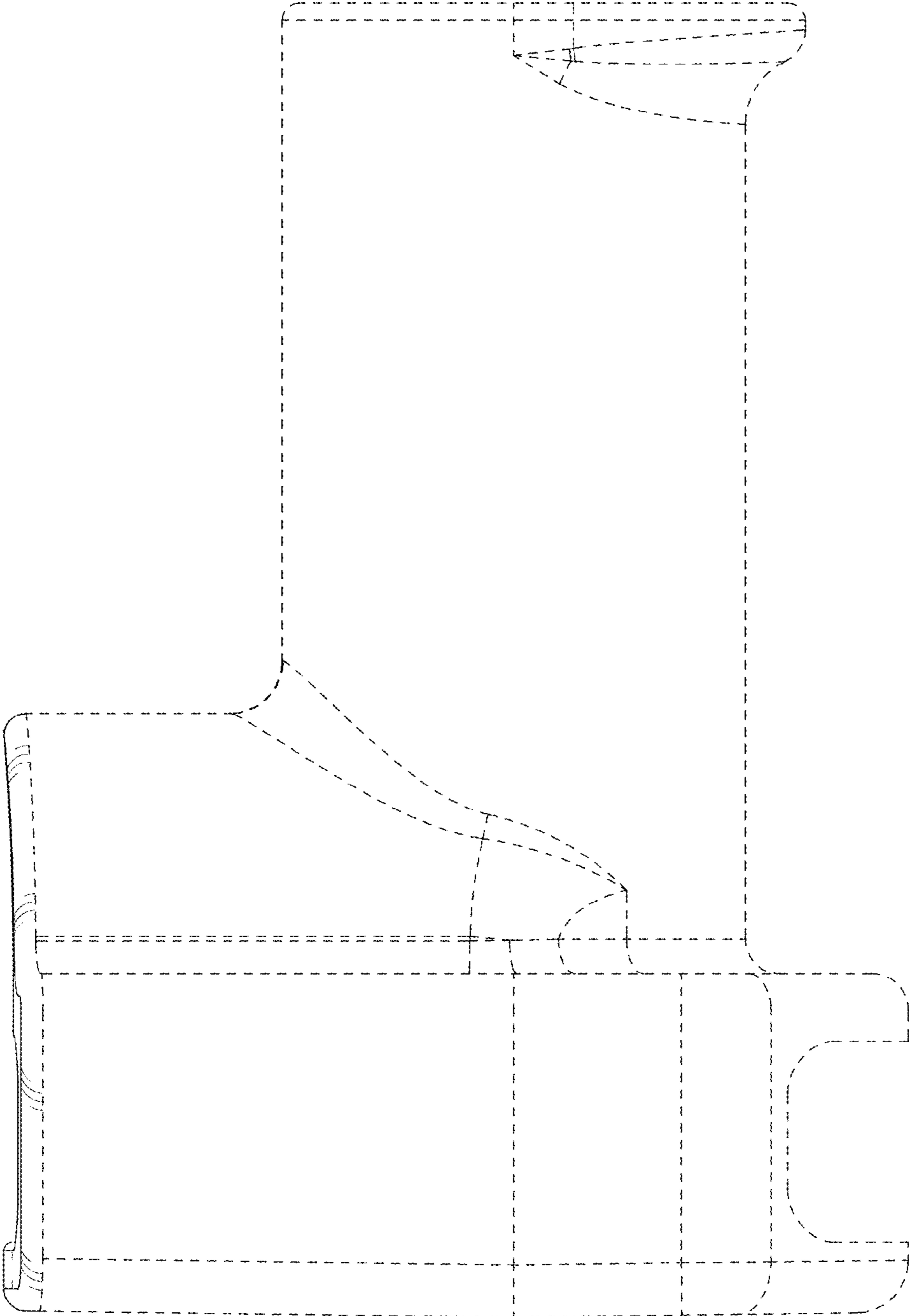

FIG. 12

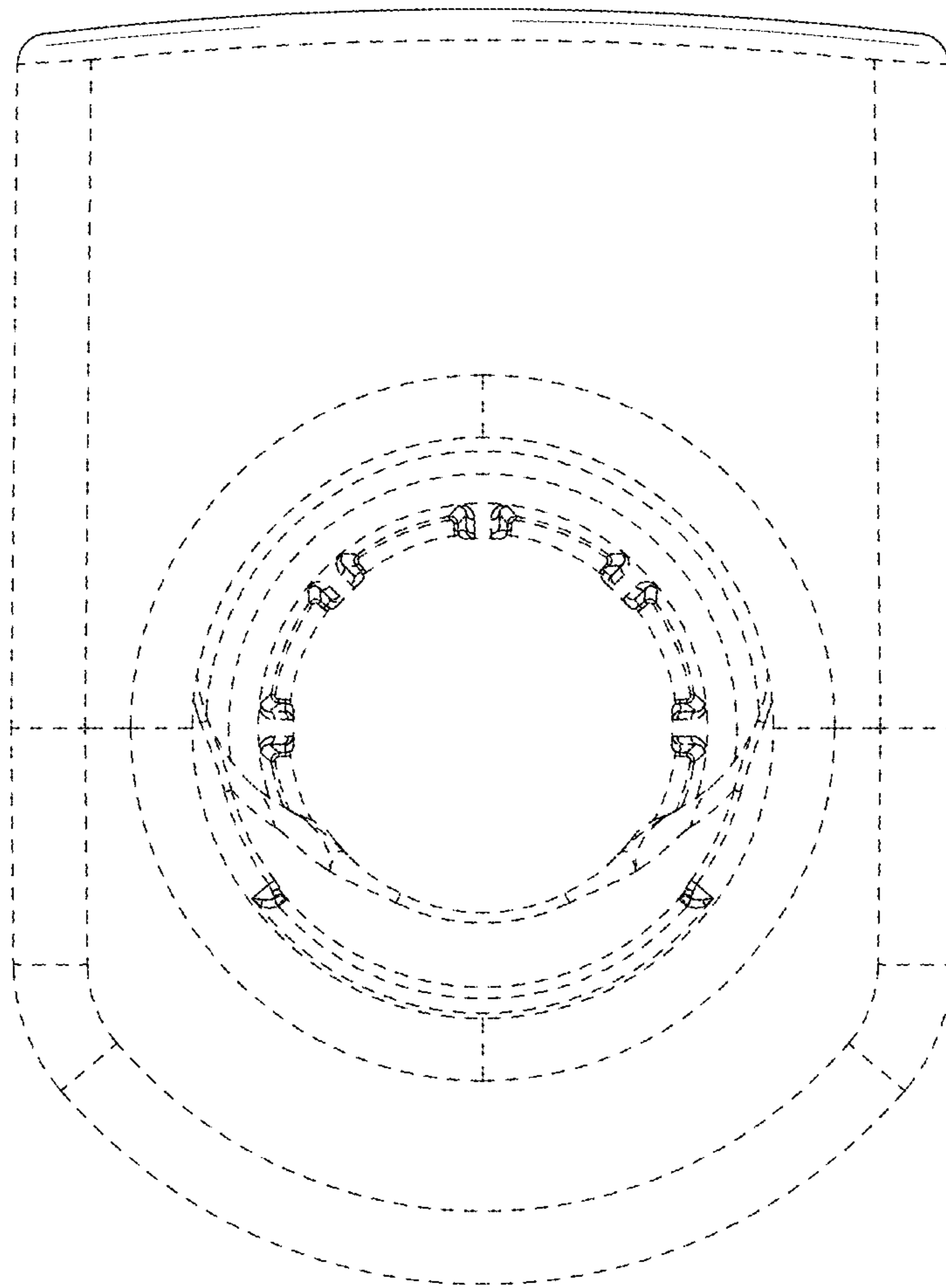

FIG. 13

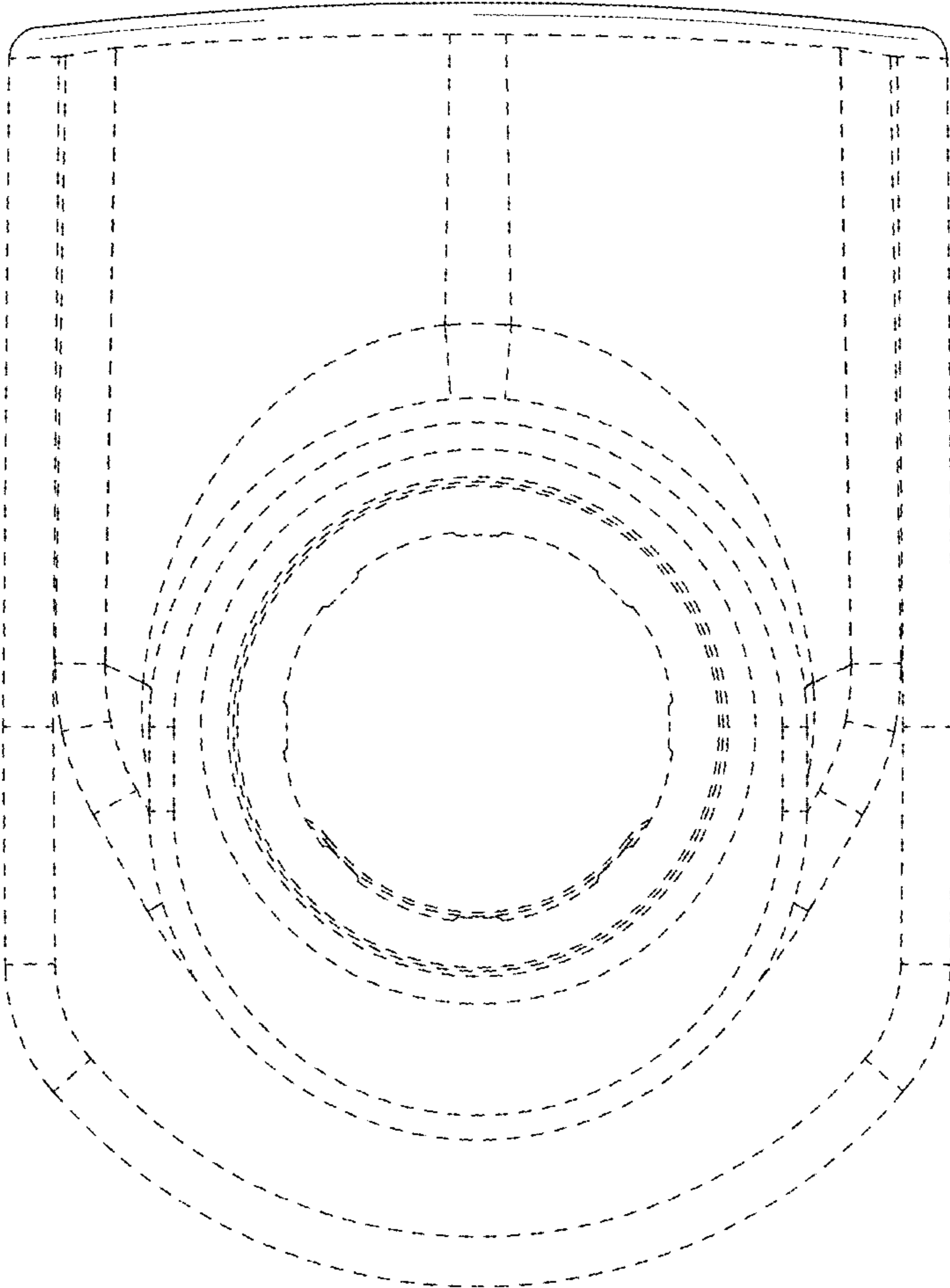

FIG. 14

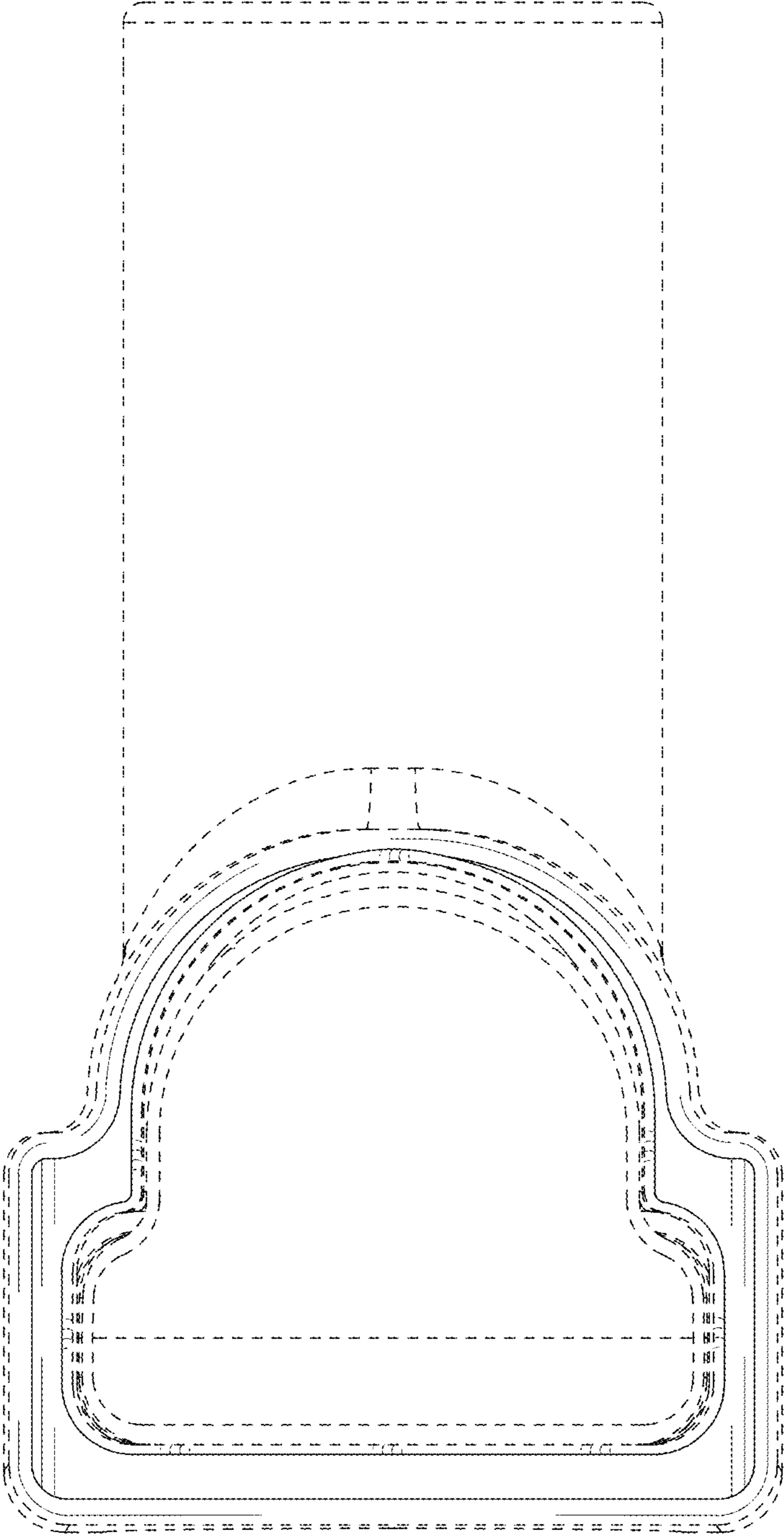

FIG. 15