



US00D751488S

(12) **United States Design Patent**  
**Zhao**

(10) **Patent No.:** **US D751,488 S**  
(45) **Date of Patent:** **\*\* Mar. 15, 2016**

- (54) **AUTOMOBILE WHEEL**
- (71) Applicant: **WAH HUNG GROUP INC.**, Monterey Park, CA (US)
- (72) Inventor: **John Zhao**, Monterey Park, CA (US)
- (73) Assignee: **Wah Hung Group Inc.**, Monterey Park, CA (US)
- (\*\*) Term: **14 Years**
- (21) Appl. No.: **29/506,030**
- (22) Filed: **Oct. 12, 2014**
- (51) **LOC (10) Cl.** ..... **12-16**
- (52) **U.S. Cl.**  
USPC ..... **D12/211**
- (58) **Field of Classification Search**  
USPC ..... D12/204-213; 301/37.101, 64.101, 65  
See application file for complete search history.

- D667,769 S \* 9/2012 Pollmann ..... D12/209
- D697,011 S \* 1/2014 Kang ..... D12/209
- D712,331 S \* 9/2014 Breyton ..... D12/209
- D718,207 S \* 11/2014 Grake ..... D12/211
- D731,391 S \* 6/2015 Zhao ..... D12/211
- D733,633 S \* 7/2015 Gardavsky ..... D12/211

**OTHER PUBLICATIONS**

Search Results for IN/ernie AND IN/alfonso on Dec. 21, 2014.  
Search results of IN/john AND TTL/wheel AND IN/zhao on Dec. 19, 2014.

\* cited by examiner

*Primary Examiner* — Ian Simmons  
*Assistant Examiner* — Samantha Q Lawrence  
(74) *Attorney, Agent, or Firm* — Payam Moradian

(57) **CLAIM**  
I claim the ornamental design for an automobile wheel, as shown and described.

(56) **References Cited**

**U.S. PATENT DOCUMENTS**

- D526,948 S \* 8/2006 Truebsbach ..... D12/211
- D585,010 S \* 1/2009 Pollmann ..... D12/211
- D593,922 S \* 6/2009 Blasi ..... D12/211
- D617,719 S \* 6/2010 Zhao ..... D12/211
- D619,952 S \* 7/2010 Juergens ..... D12/211
- D655,234 S \* 3/2012 Zhao ..... D12/211
- D666,953 S \* 9/2012 Pollmann ..... D12/209

**DESCRIPTION**

FIG. 1 is a front elevational view of an automobile wheel; and, FIG. 2 is a perspective view thereof. The broken lines shown in FIG. 2 illustrate portions of the automobile wheel that form no part of the claimed design.

**1 Claim, 2 Drawing Sheets**

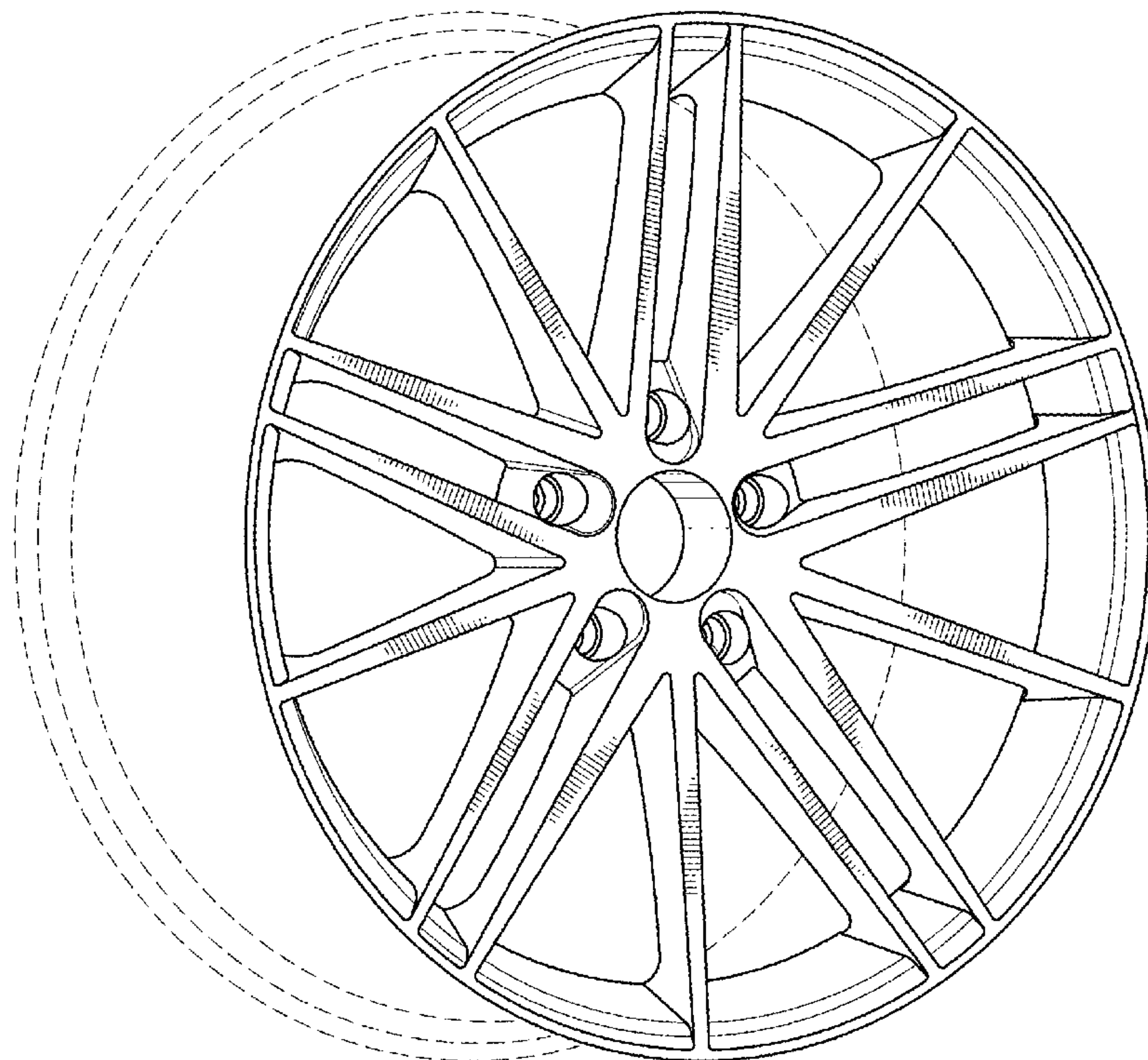

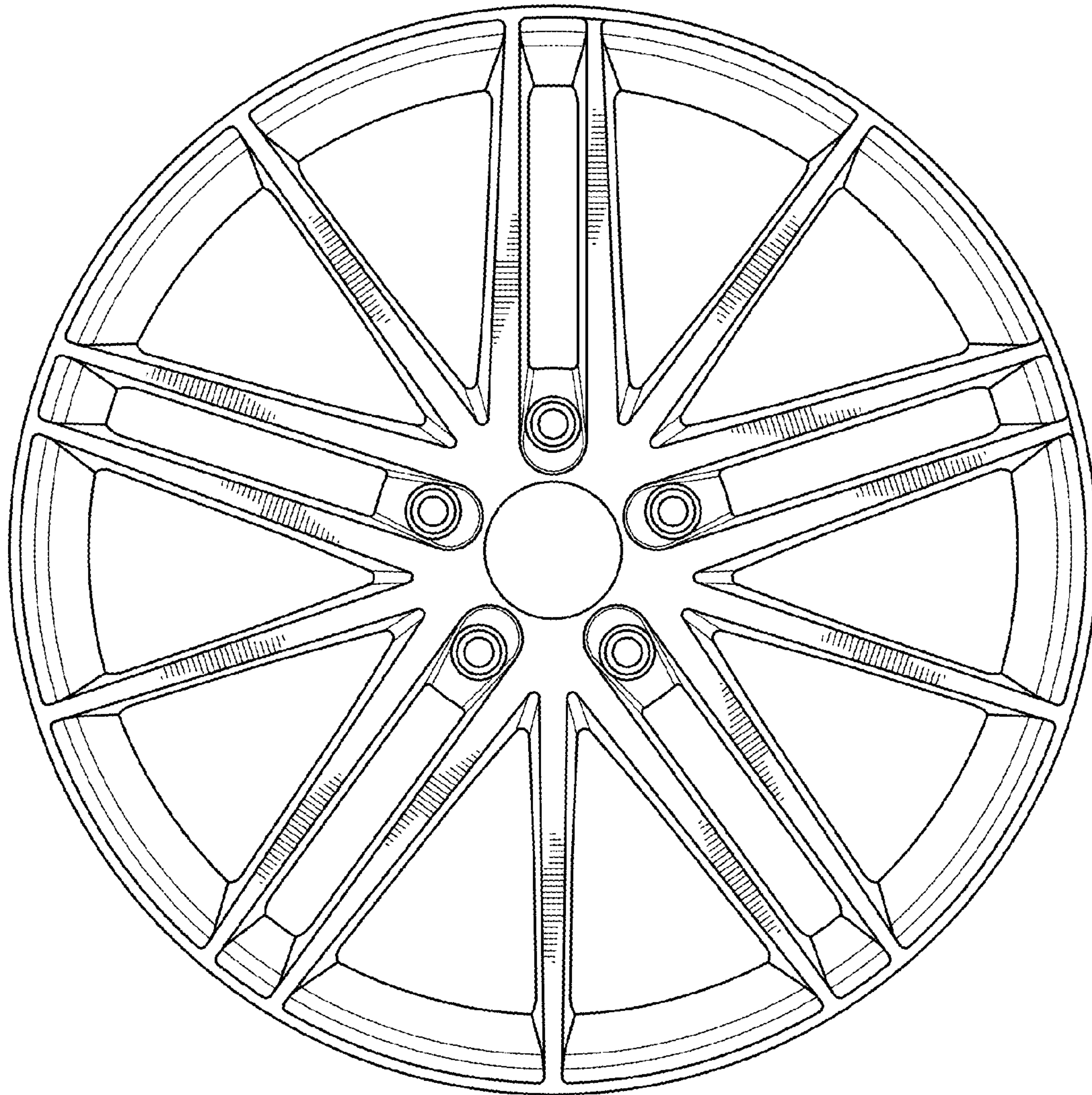

*FIG. 1*



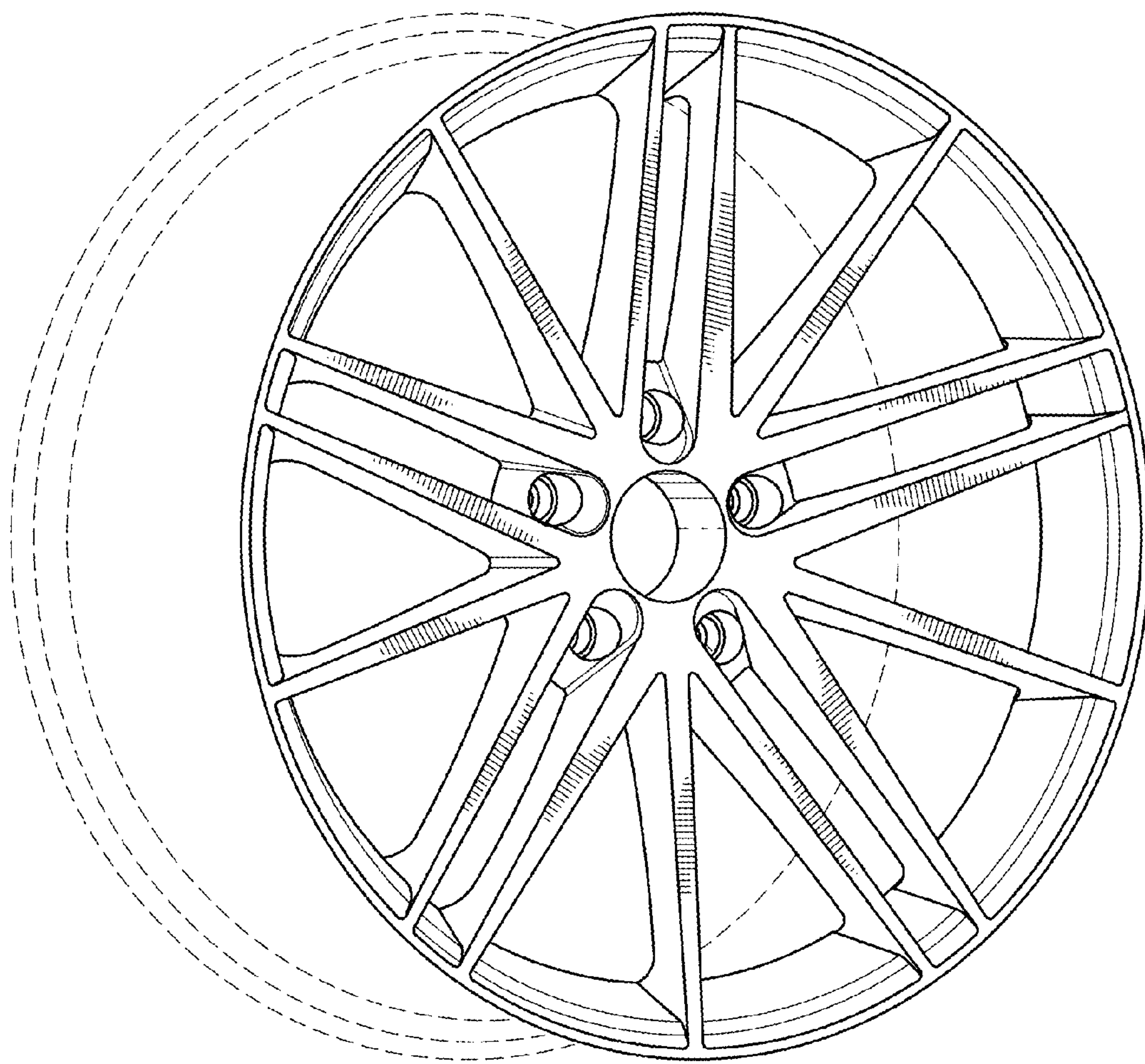

FIG. 2