



US00D751285S

(12) **United States Design Patent**  
**Yoo**

(10) **Patent No.:** **US D751,285 S**  
(45) **Date of Patent:** **\*\* Mar. 15, 2016**

(54) **SATCHEL**

(71) Applicant: **Right Brain Holdings LLC**, Mayfield Heights, OH (US)

(72) Inventor: **Jeasung Jay Yoo**, Highland Heights, OH (US)

(73) Assignee: **Right Brain Holdings, LLC**, Mayfield Heights, OH (US)

(\*\*) Term: **14 Years**

(21) Appl. No.: **29/503,486**

(22) Filed: **Sep. 26, 2014**

(51) **LOC (10) Cl.** ..... **03-01**

(52) **U.S. Cl.**  
USPC ..... **D3/232**

(58) **Field of Classification Search**  
USPC ..... D3/232–233, 240–243, 245–246, 247, D3/249–253  
CPC ..... A45C 1/024; A45C 3/08; A45C 1/06  
See application file for complete search history.

(56) **References Cited**

**U.S. PATENT DOCUMENTS**

D384,812 S \* 10/1997 Heffelfinger ..... D3/243

**OTHER PUBLICATIONS**

“Matthew McConaughey is Bringing Back the Fanny Pack,”  
Huffington Post (2014).

\* cited by examiner

*Primary Examiner* — Holly Baynham

(74) *Attorney, Agent, or Firm* — Walters & Wasylyna LLC

(57) **CLAIM**

The ornamental design for a satchel, as shown and described.

**DESCRIPTION**

FIG. 1 is a rear and left-side isometric view of a satchel in accordance with the present design;  
FIG. 2 is a rear elevational view of the satchel of FIG. 1;  
FIG. 3 is a front elevational view of the satchel of FIG. 1;  
FIG. 4 is a right side elevational view of the satchel of FIG. 1;  
FIG. 5 is a left side elevational view of the satchel of FIG. 1;  
FIG. 6 is a top plan view of the satchel of FIG. 1;  
FIG. 7 is a bottom plan view of the satchel of FIG. 1; and,  
FIG. 8 is a rear and left-side isometric view of the satchel of FIG. 1, showing how the satchel may be worn by an adult human.

The broken lines, including the less-prominent broken lines representing stitching, are included for purposes of illustrating environment and form no part of the claimed design.

**1 Claim, 8 Drawing Sheets**

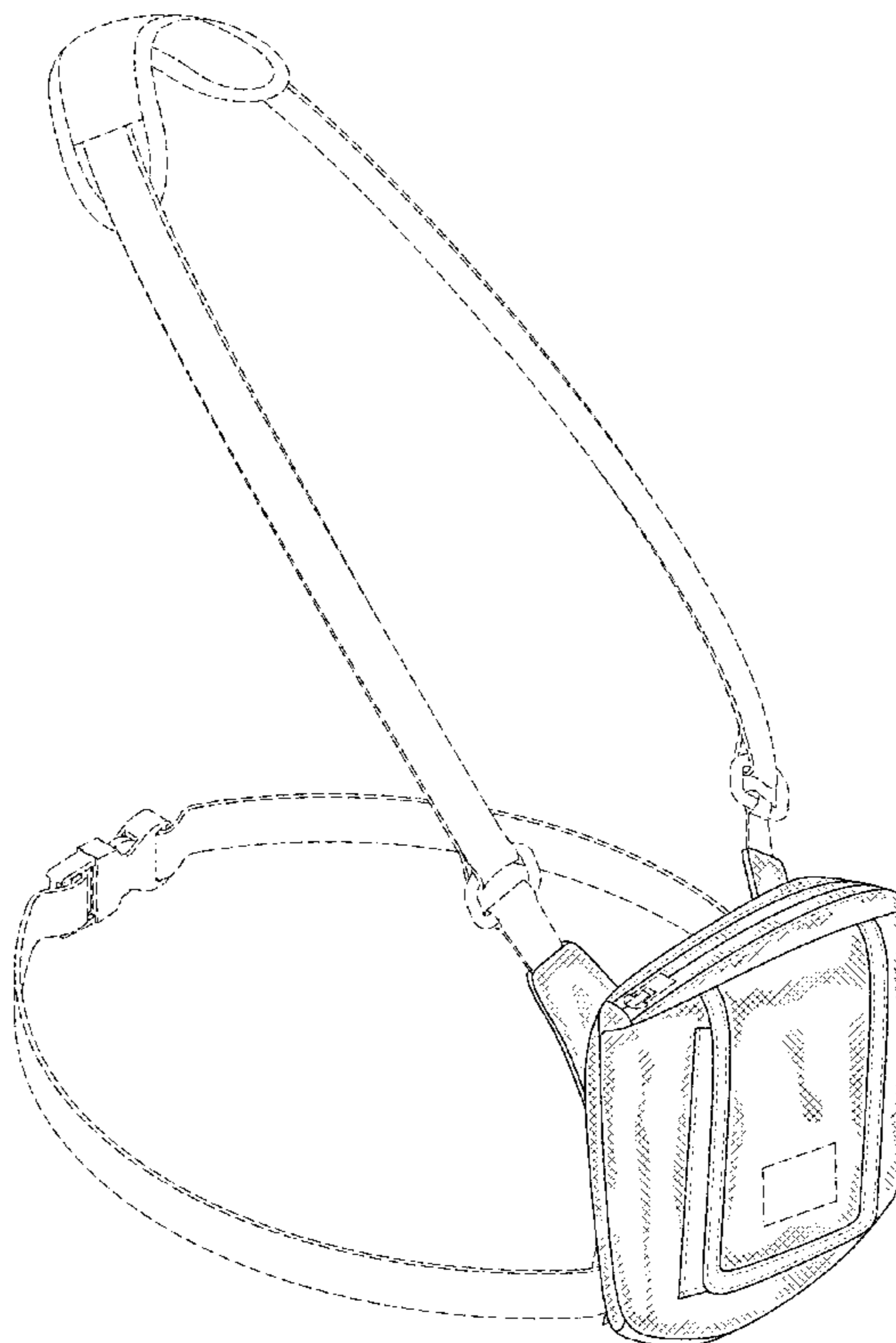

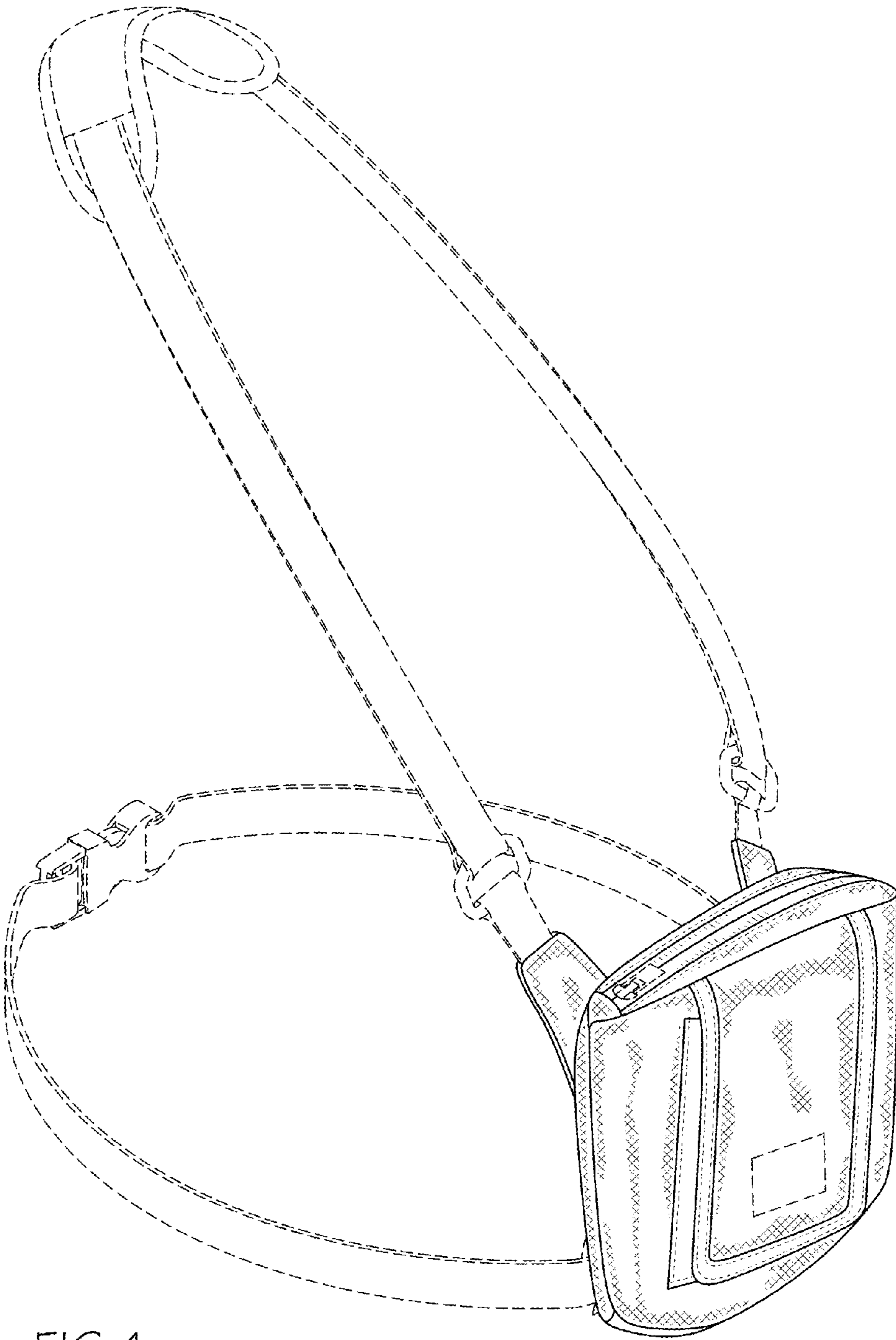

FIG. 1

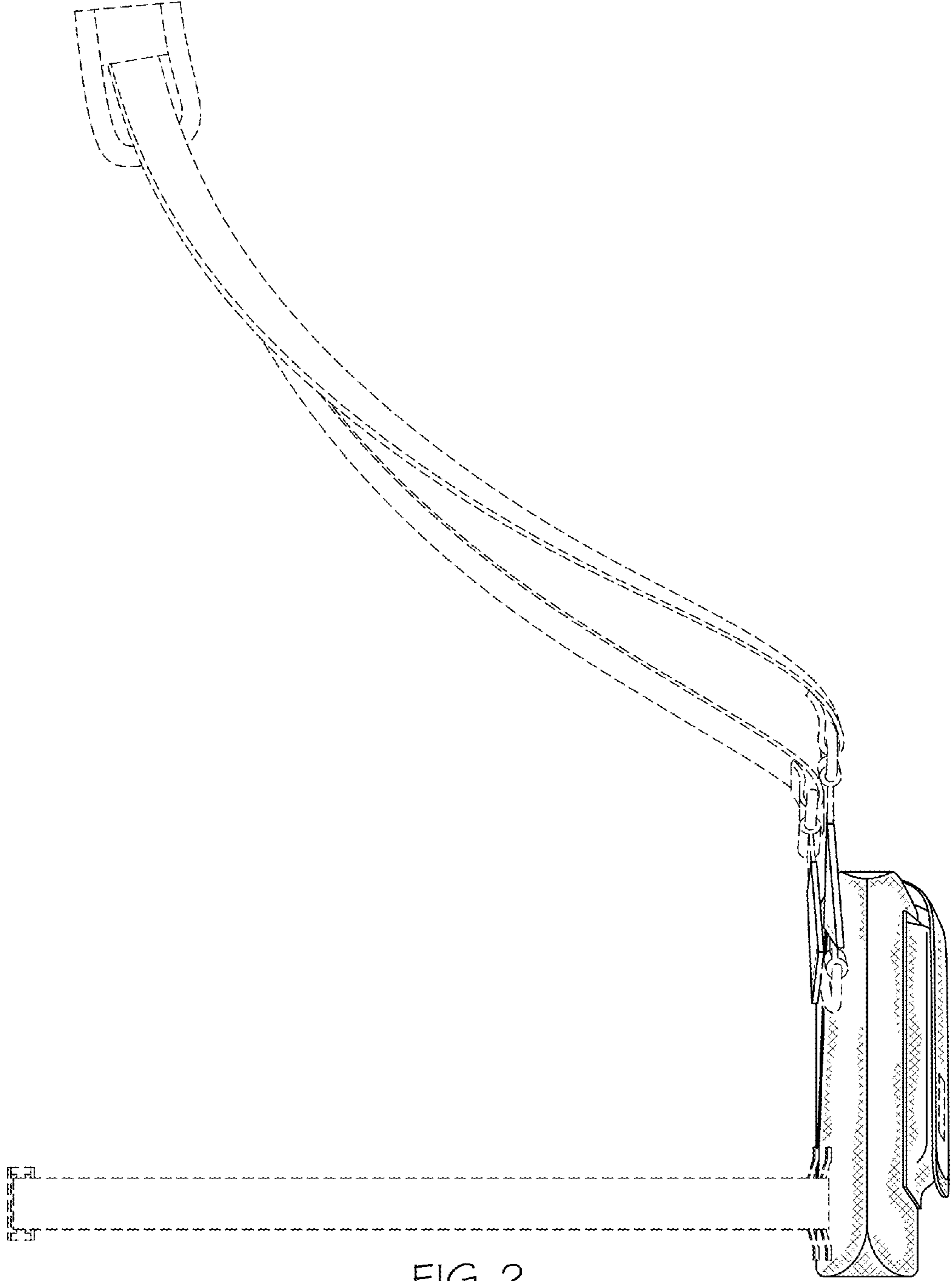

FIG. 2

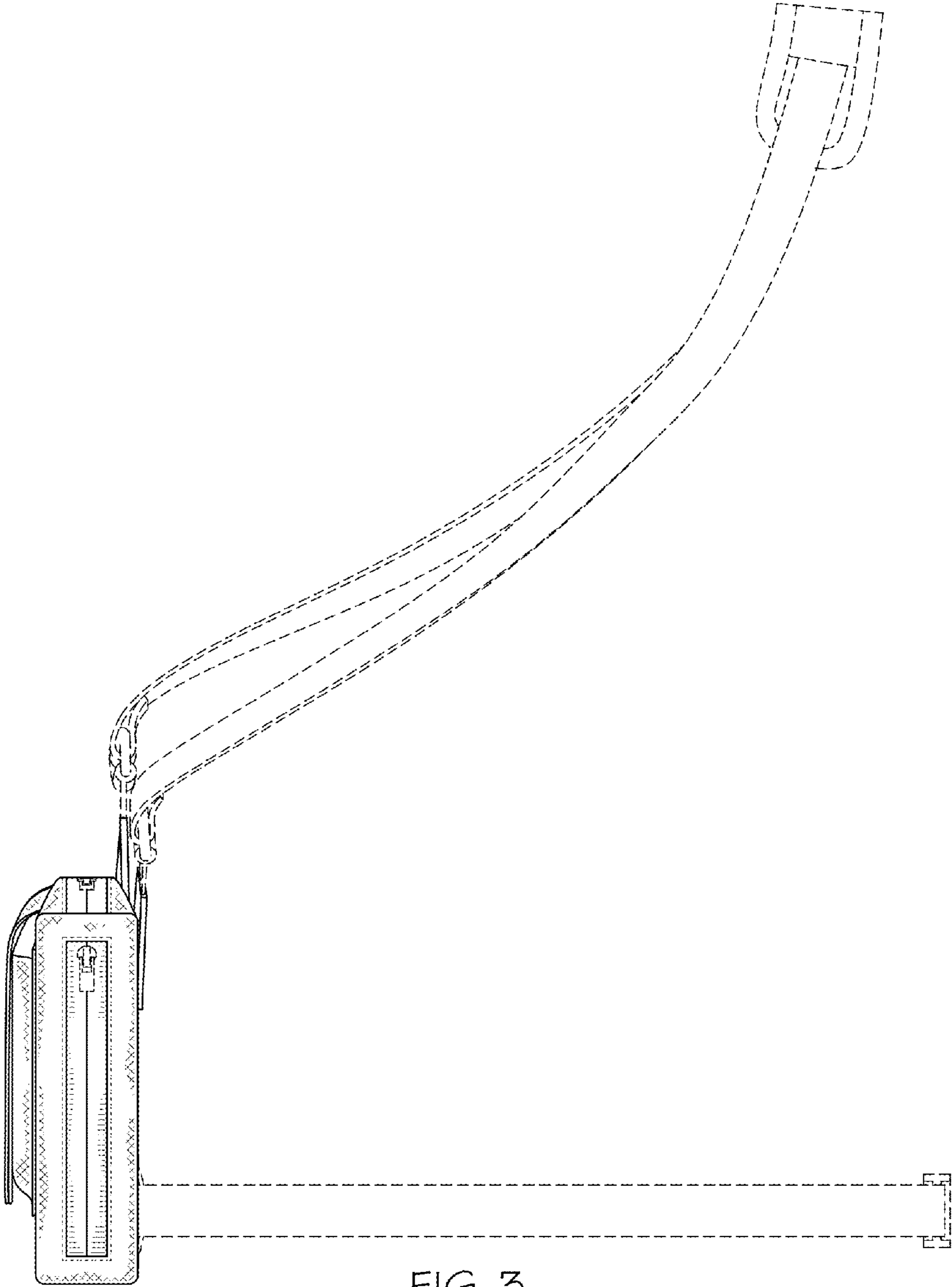

FIG. 3

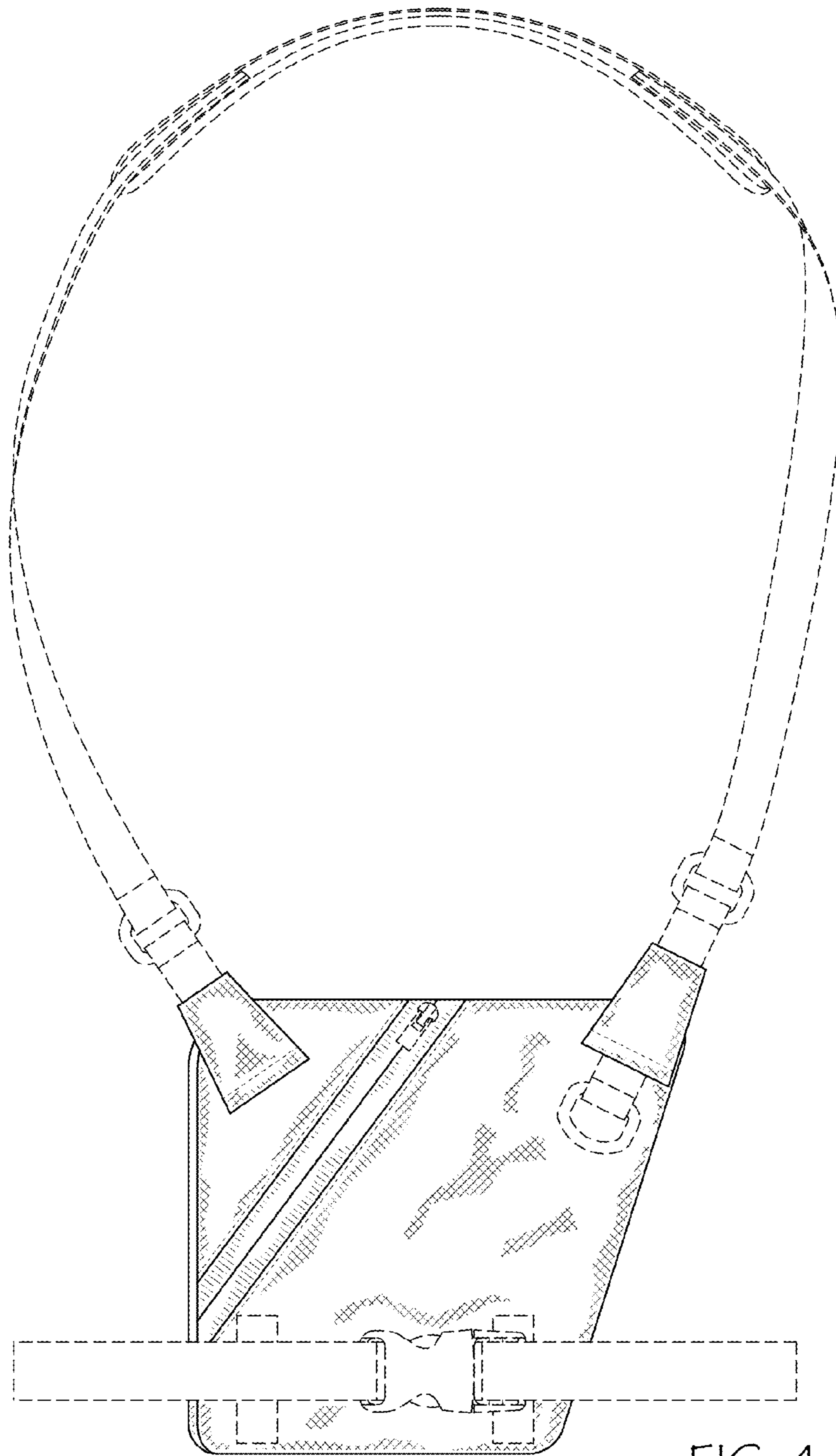

FIG. 4

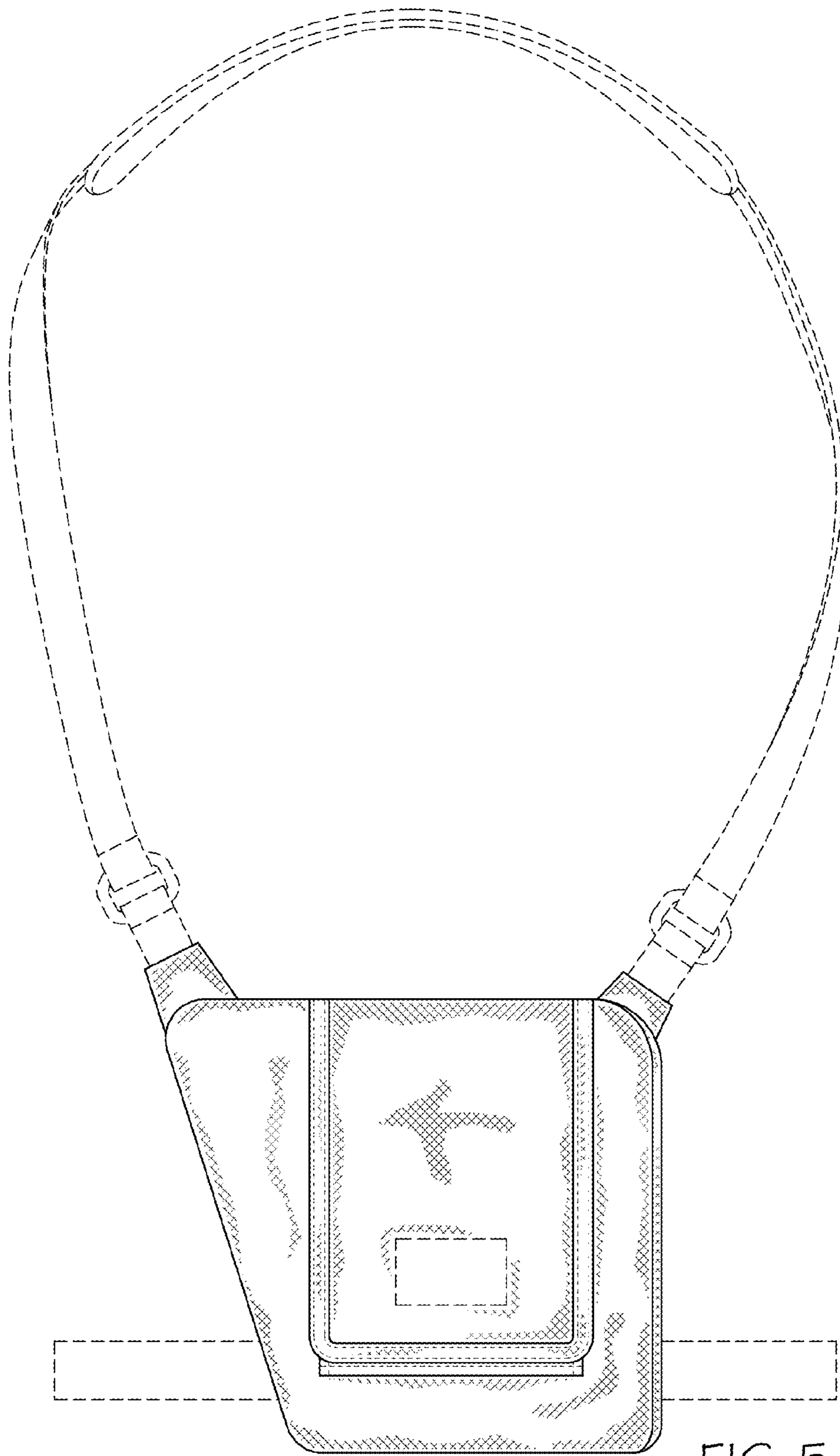

FIG. 5

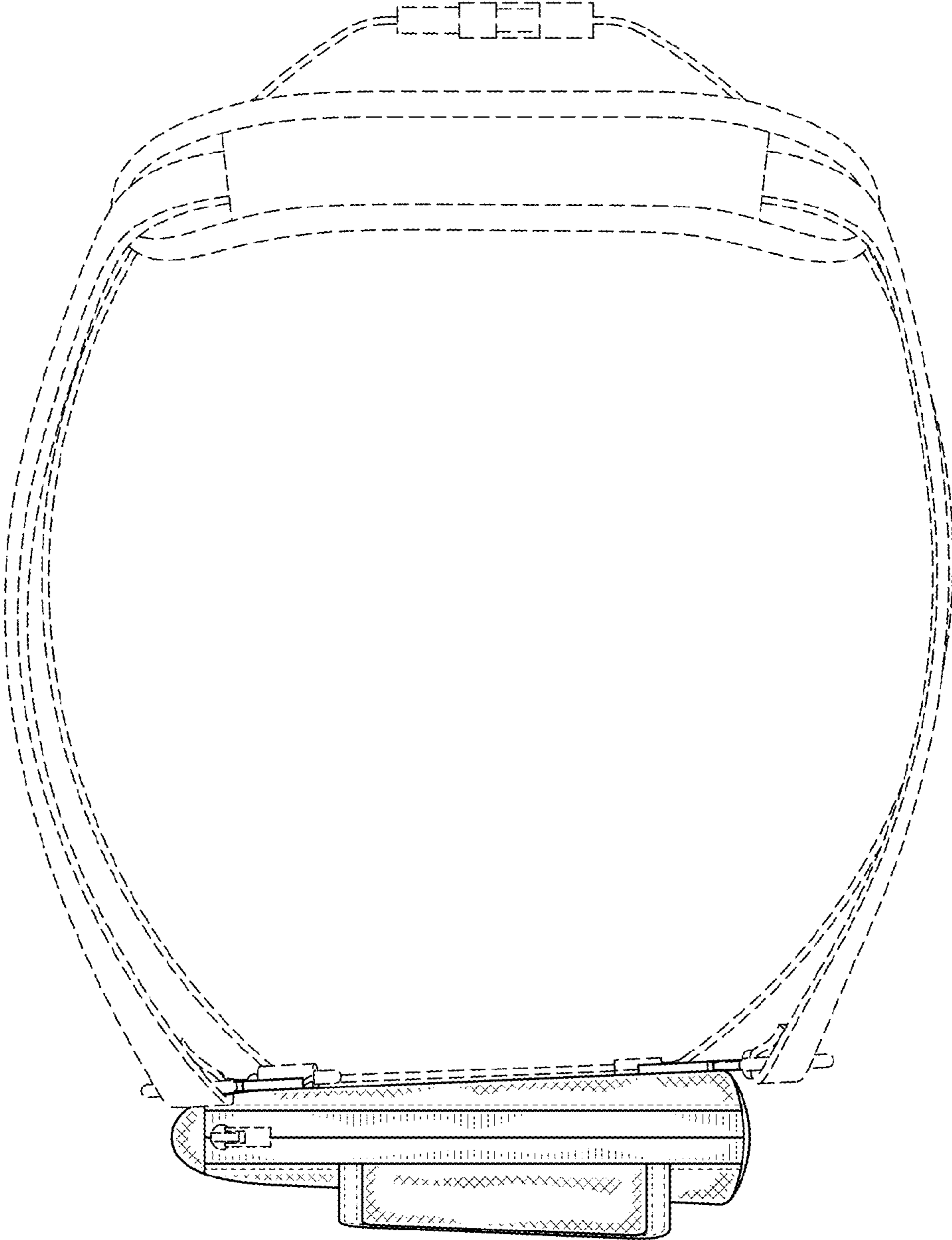

FIG. 6

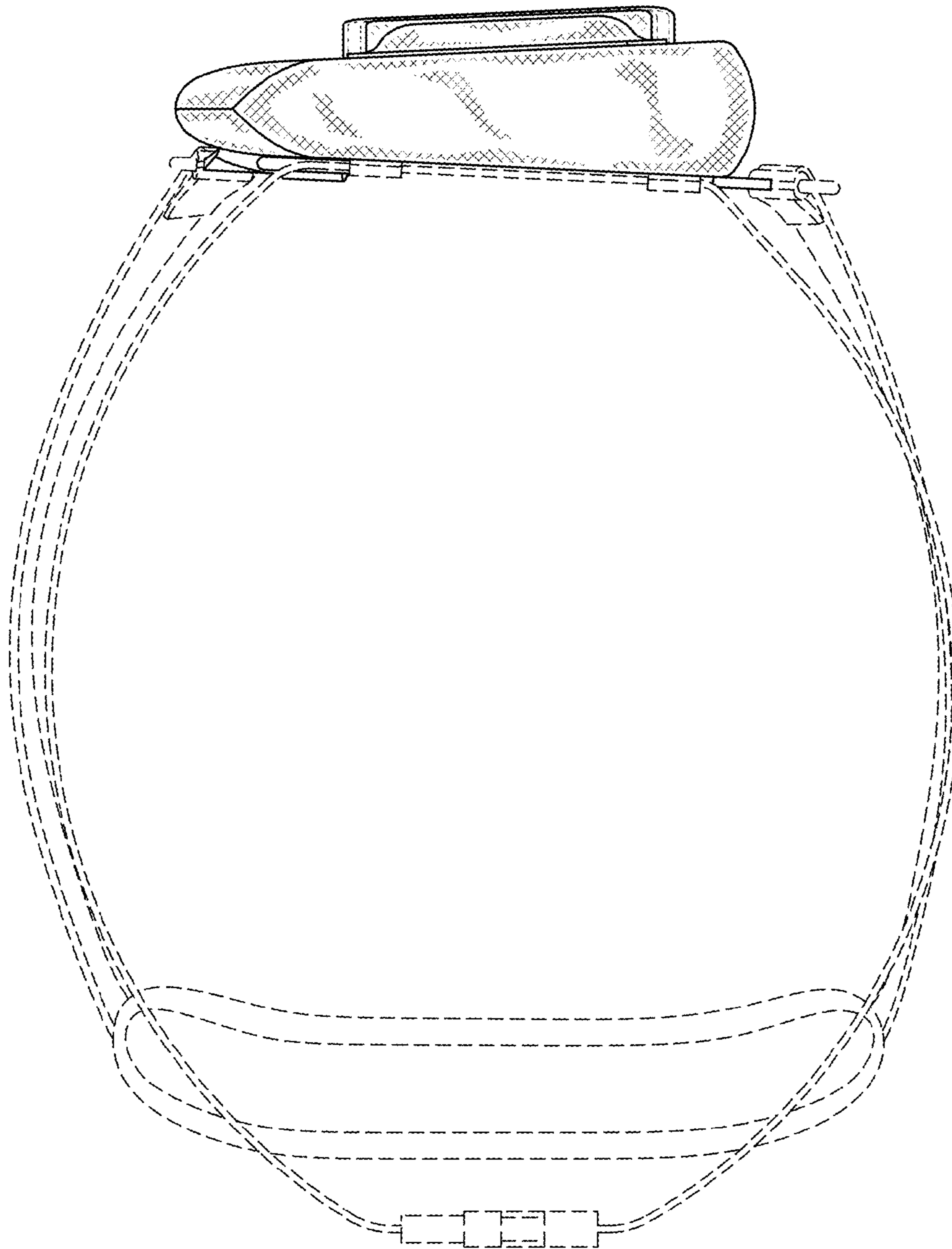

FIG. 7



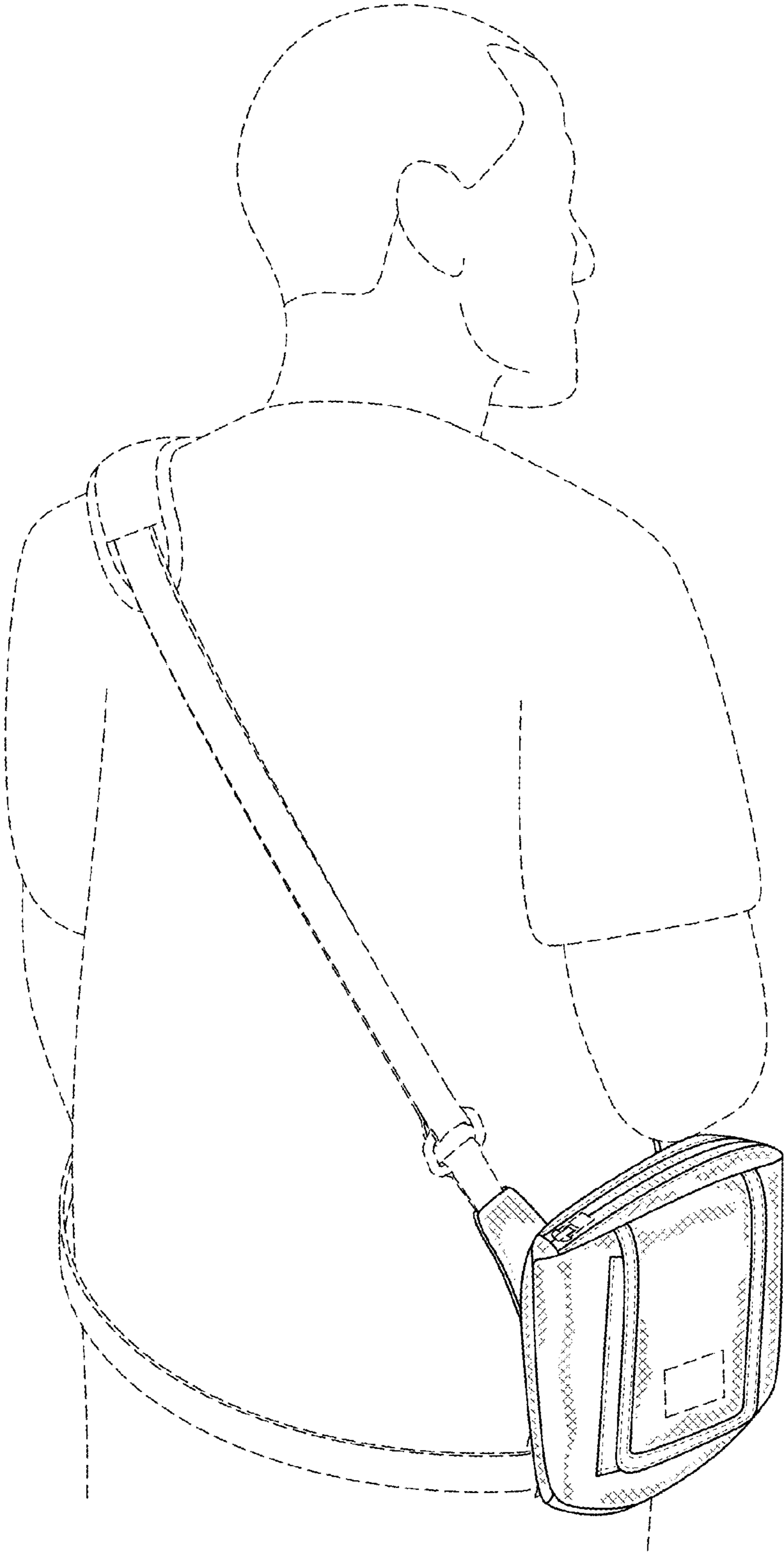

FIG. 8