



US00D751265S

(12) **United States Design Patent**  
**Bromm et al.**

(10) **Patent No.:** **US D751,265 S**  
(45) **Date of Patent:** **\*\* Mar. 8, 2016**

(54) **MOLDED WHEEL**  
(71) Applicants: **Scott Bromm**, Lake Geneva, WI (US);  
**William N. Lechner**, Burlington, WI (US)  
(72) Inventors: **Scott Bromm**, Lake Geneva, WI (US);  
**William N. Lechner**, Burlington, WI (US)

D586,071 S \* 2/2009 Morris ..... D34/27  
D586,072 S \* 2/2009 Morris ..... D34/27  
D632,044 S \* 2/2011 Morris ..... D34/27  
D640,439 S \* 6/2011 Morris ..... D34/27  
D679,882 S \* 4/2013 Frenkel ..... D34/27  
D702,411 S \* 4/2014 Bromm ..... D34/10  
9,096,097 B2 \* 8/2015 Trent, III ..... B60B 37/06  
2009/0127323 A1 \* 5/2009 Zeiler ..... B29C 53/50  
229/116  
2013/0200583 A1 \* 8/2013 Morris ..... B65F 1/1473  
280/47.26

(73) Assignee: **Poly-Flex, Inc.**, Walworth, WI (US)  
(\*\*) Term: **14 Years**

\* cited by examiner  
*Primary Examiner* — Cynthia Ramirez  
(74) *Attorney, Agent, or Firm* — D L Tschida

(21) Appl. No.: **29/474,692**  
(22) Filed: **Dec. 29, 2014**  
(51) **LOC (10) Cl.** ..... **12-05**  
(52) **U.S. Cl.**  
USPC ..... **D34/27**

(57) **CLAIM**  
The ornamental design for a molded wheel, as shown and described.

(58) **Field of Classification Search**  
USPC ..... D34/12-27; D12/211, 204, 205, 501,  
D12/209, 88, 135; 301/64.1, 109; D7/402;  
280/282, 47.31, 87.042, 47.131, 47.26;  
D21/141, 71, 76  
CPC .... B60B 37/06; B60B 37/10; B60B 2200/41;  
B60B 19/00; B62B 1/10; B62B 3/14; B62B  
3/1472; B62B 3/144  
See application file for complete search history.

**DESCRIPTION**  
FIG. 1 is a perspective drawing showing a front and side views of our new design for a molded wheel.  
FIG. 2 is a front view thereof;  
FIG. 3 is a rear view thereof;  
FIG. 4 is a cross section view taken from FIG. 3 along section lines 4-4;  
FIG. 5 is a side view thereof, wherein the other side is a mirror image and wherein a spacer bushing fitted to the hub is shown with a symbolic break in length; and,  
FIG. 6 is a perspective drawing showing an enlarged partial section of the wheel and wherein partial rear and side views are shown thereof.  
The spacer bushing projecting from the wheel's hub is shown with a symbolic break in its length. The appearance of any portion of the article between the break lines forms no part of the claimed design.

(56) **References Cited**  
U.S. PATENT DOCUMENTS  
D276,513 S \* 11/1984 Honsa ..... D12/204  
D327,048 S \* 6/1992 Markling ..... D12/204  
6,170,920 B1 \* 1/2001 Markling ..... B60B 37/10  
301/111.01  
D570,070 S \* 5/2008 Morris ..... D12/204  
7,481,498 B1 \* 1/2009 Morris ..... B60B 3/001  
152/324

**1 Claim, 6 Drawing Sheets**

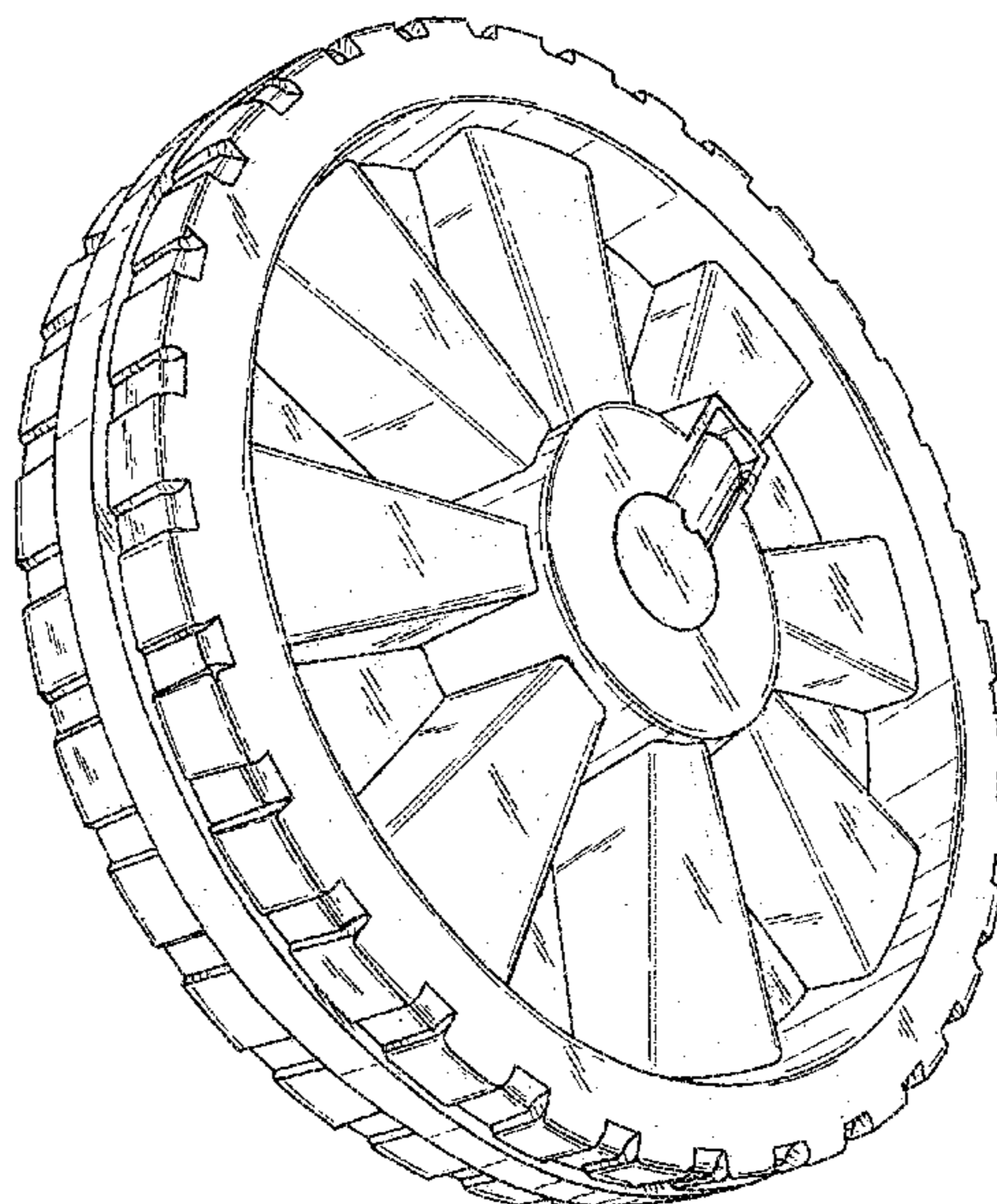

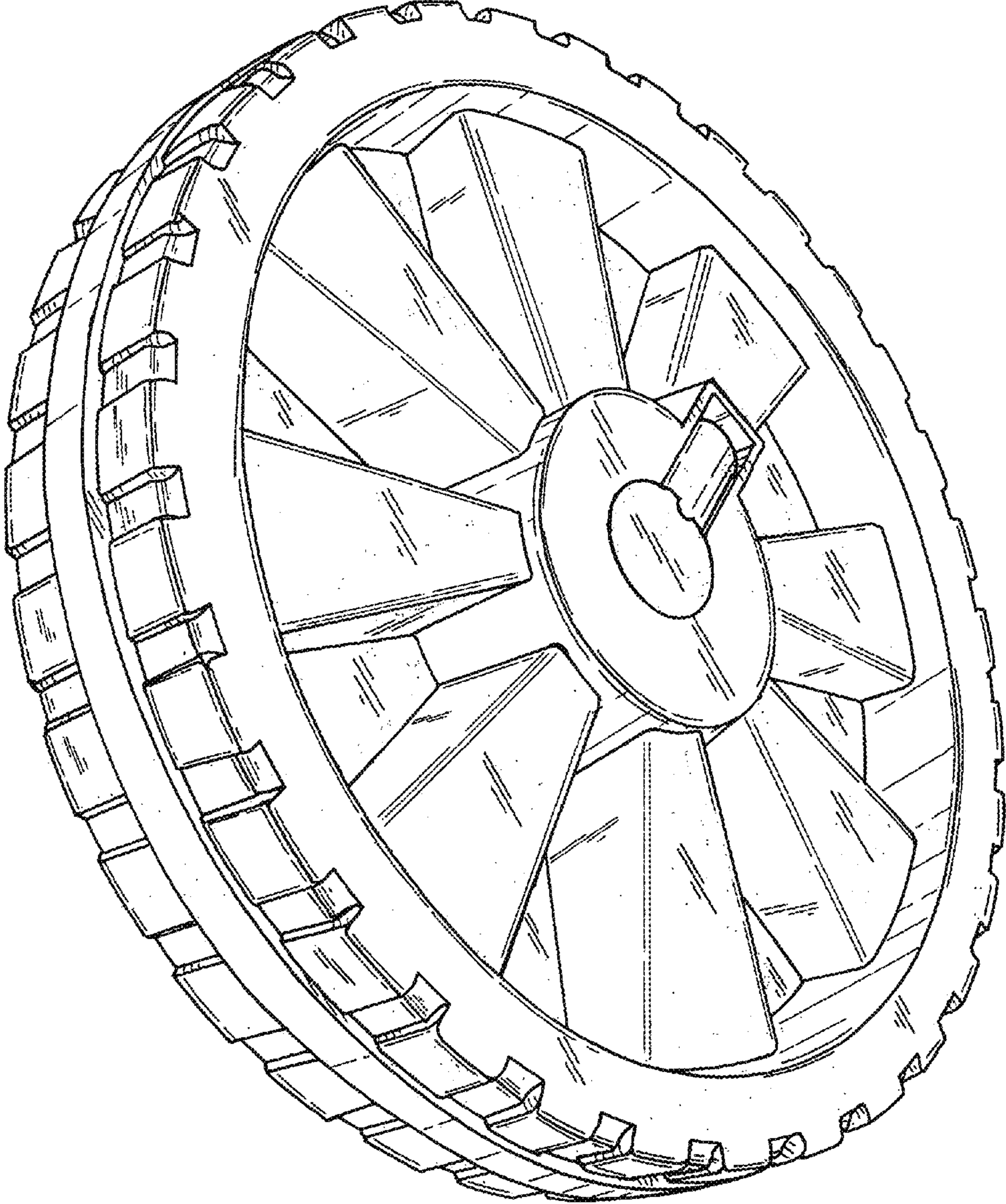

FIG. 1

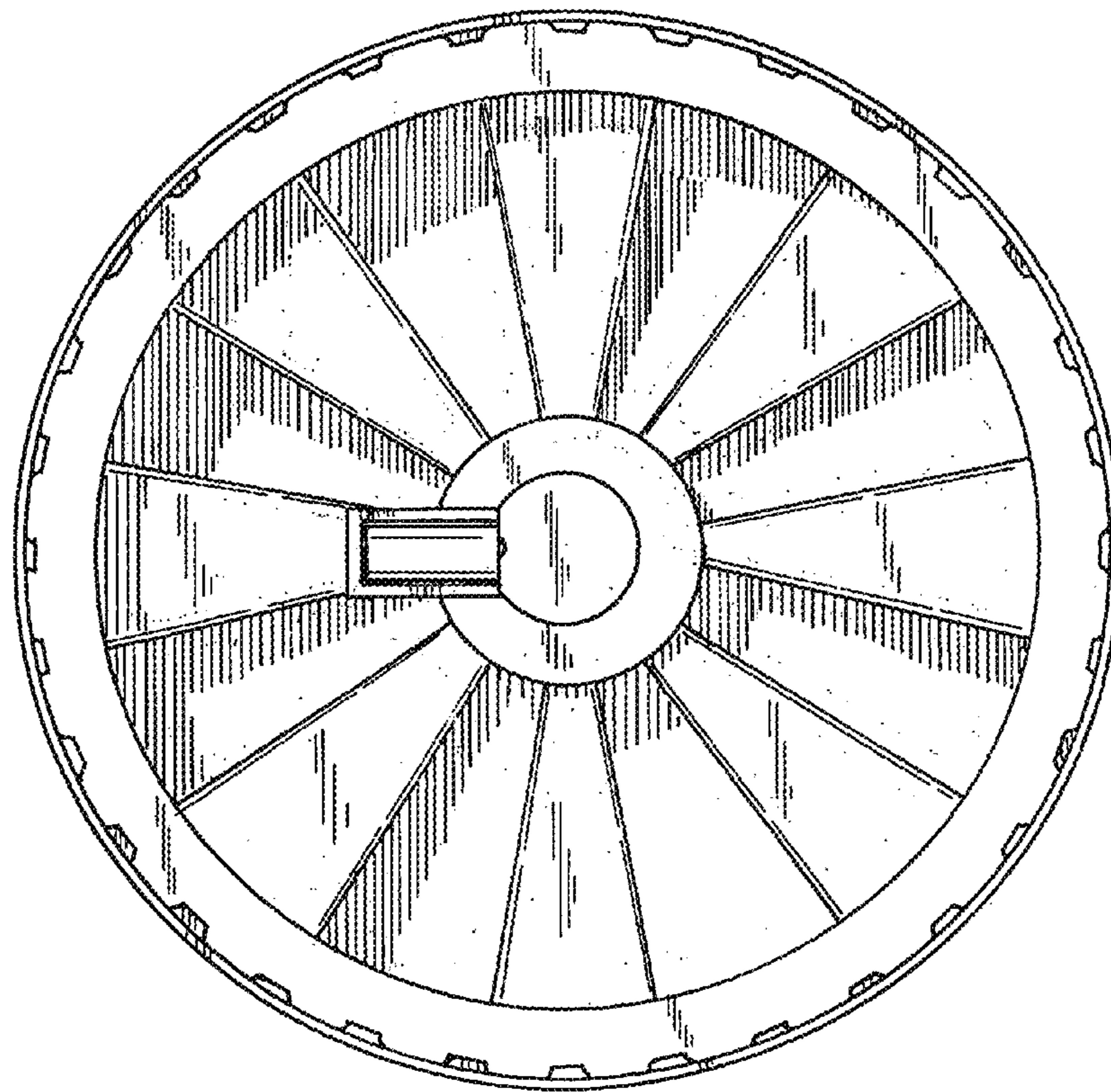

FIG. 2

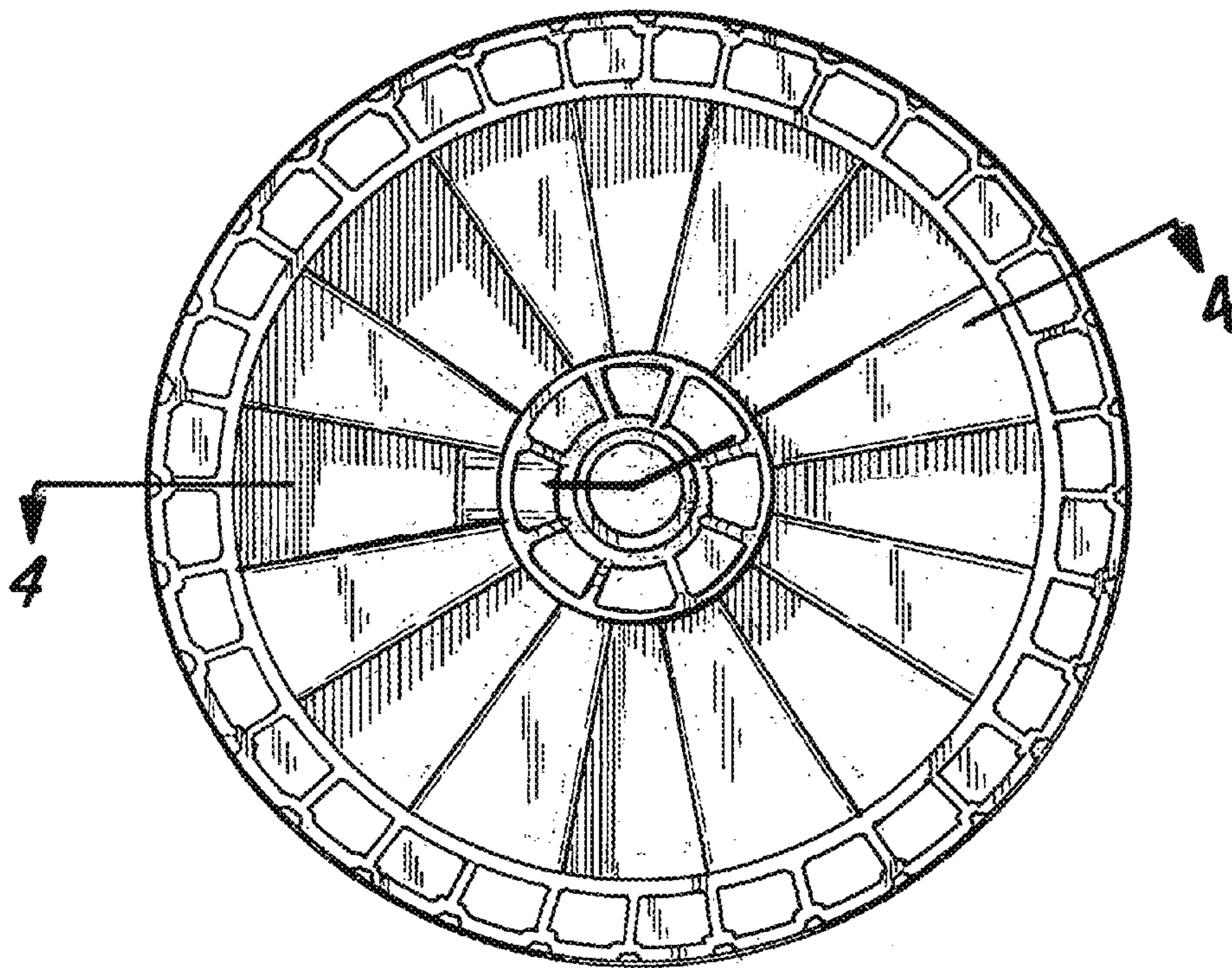

FIG. 3

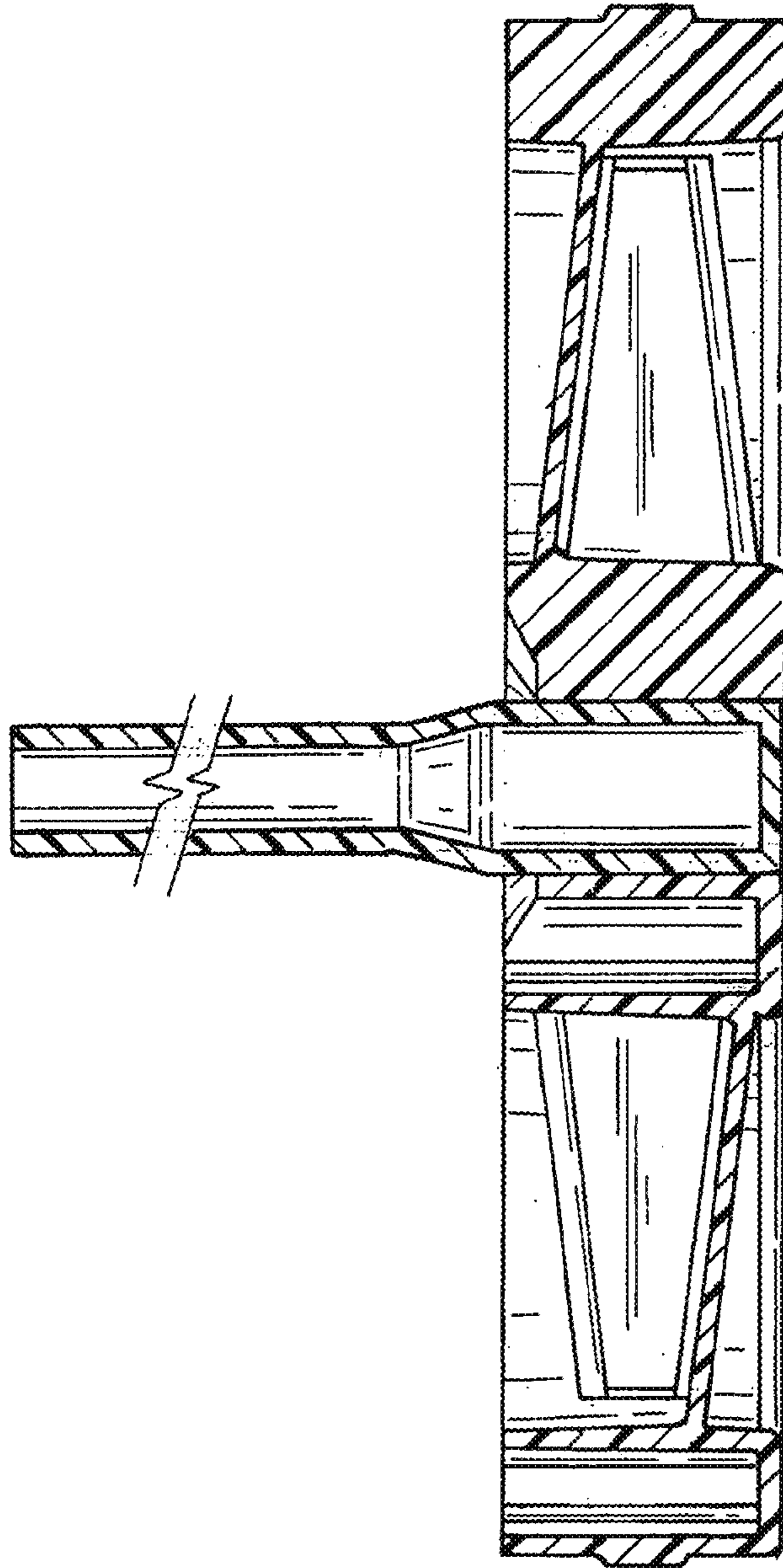
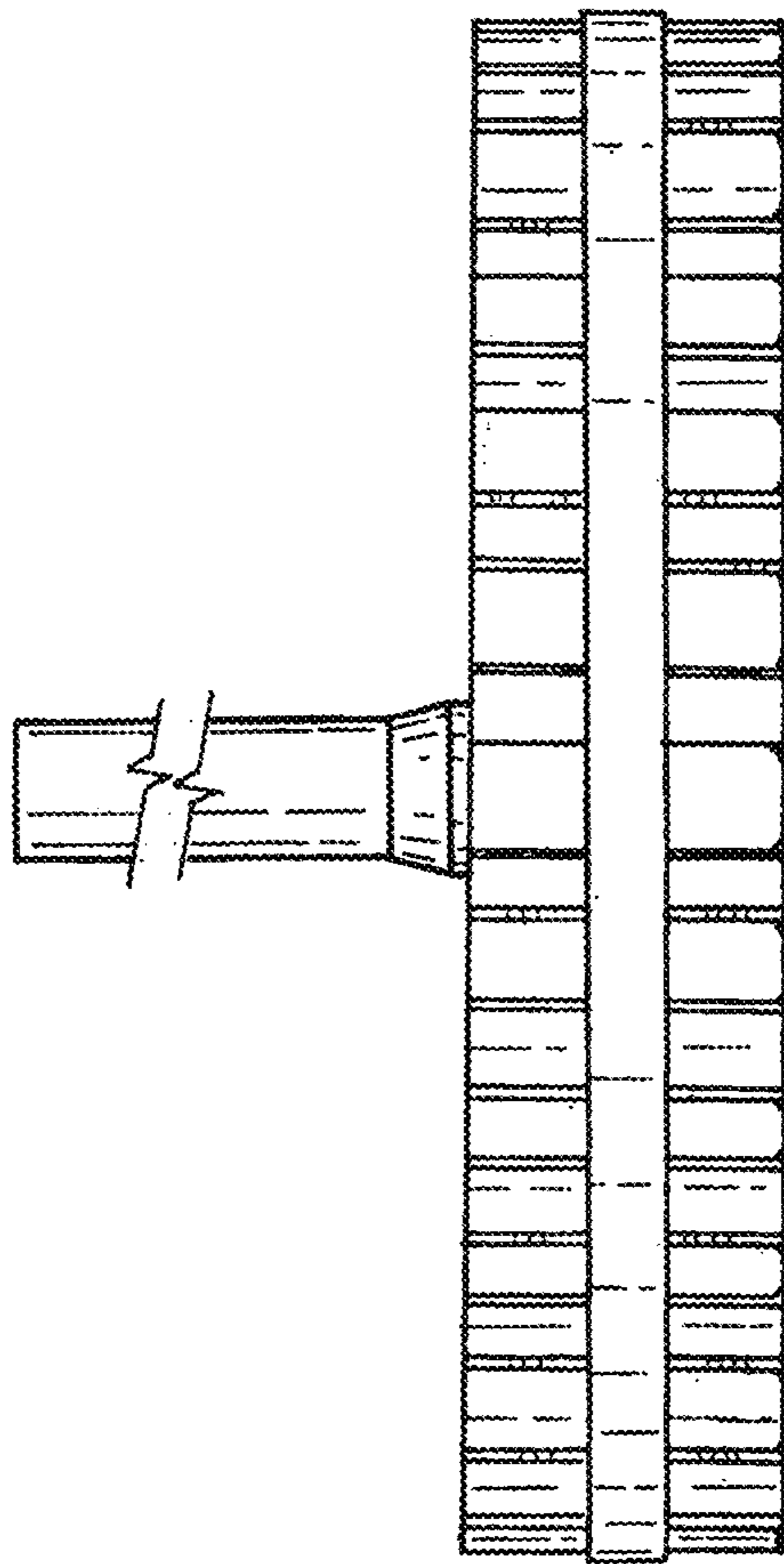

FIG. 4



*FIG. 5*

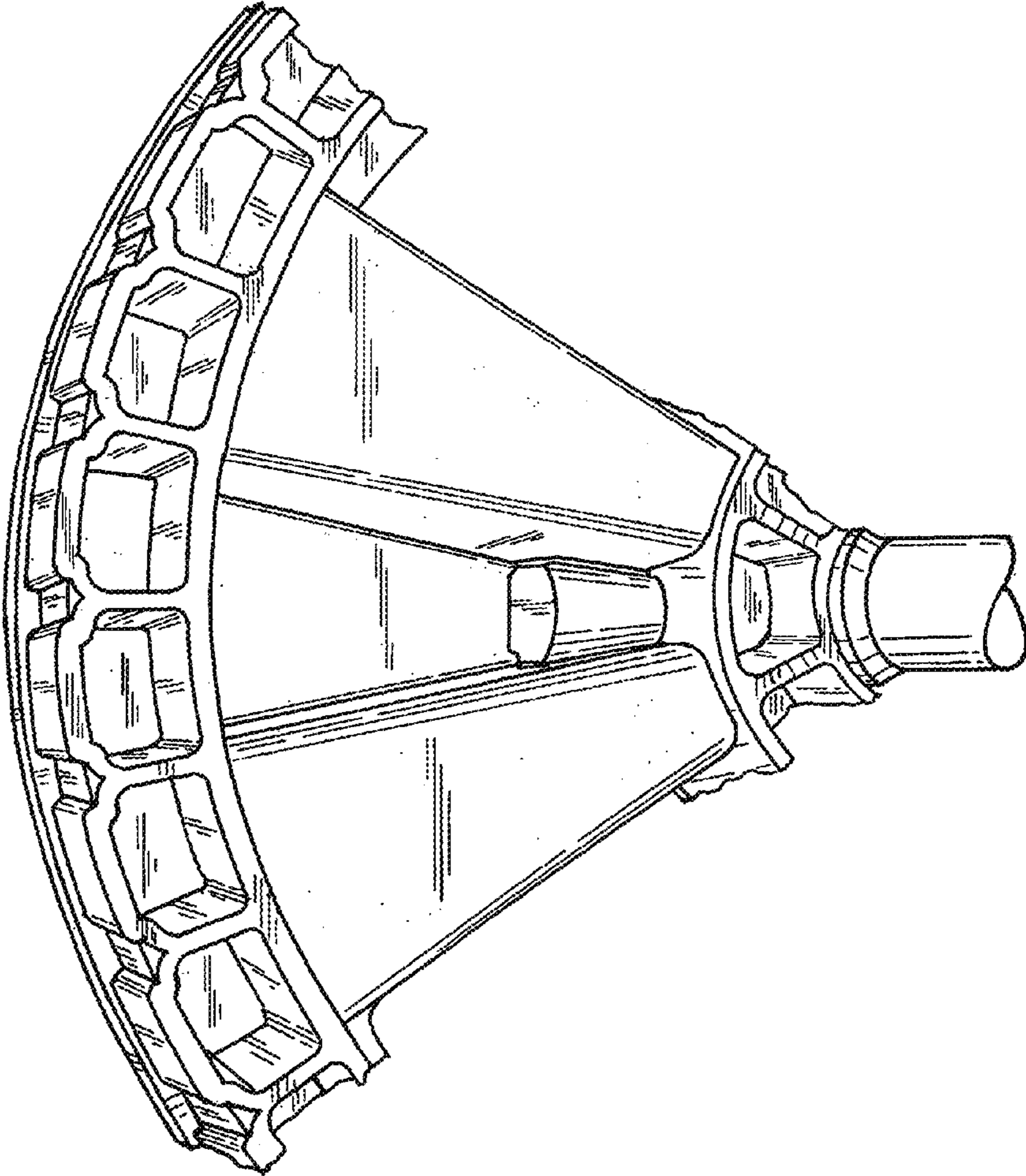

FIG. 6