



US00D751146S

(12) **United States Design Patent**  
**Casciotti et al.**

(10) **Patent No.:** **US D751,146 S**  
(45) **Date of Patent:** **\*\* Mar. 8, 2016**

- (54) **WRITING INSTRUMENT**
- (71) Applicant: **Amsterdam Printing & Litho, Inc.**,  
North Mankato, MN (US)
- (72) Inventors: **David M. Casciotti**, Amsterdam, NY  
(US); **Jing Mahler**, Glenville, NY (US)
- (73) Assignee: **Amsterdam Printing & Litho, Inc.**,  
North Mankato, MN (US)
- (\*\*) Term: **14 Years**
- (21) Appl. No.: **29/509,563**
- (22) Filed: **Nov. 19, 2014**
- (51) **LOC (10) Cl.** ..... **19-06**
- (52) **U.S. Cl.**  
USPC ..... **D19/201**
- (58) **Field of Classification Search**  
USPC ..... D14/411; D19/115–204  
CPC ..... B43K 5/00; B43K 5/005; B43K 7/00;  
B43K 7/10; B43K 7/12; B43K 8/04  
See application file for complete search history.

- D626,597 S \* 11/2010 Casciotti ..... D19/201
- D628,641 S \* 12/2010 Zhang ..... D19/172
- D647,137 S \* 10/2011 Uchiyama ..... D19/172
- D648,789 S \* 11/2011 Shibata ..... D19/172
- D651,241 S \* 12/2011 Liang ..... D19/172
- D667,882 S \* 9/2012 Uchiyama ..... D19/172
- D692,483 S \* 10/2013 Laemle ..... D19/172
- D708,670 S \* 7/2014 Zhang ..... D19/172
- D716,872 S \* 11/2014 Kim ..... D19/172

\* cited by examiner

*Primary Examiner* — Elizabeth Albert

(74) *Attorney, Agent, or Firm* — Dicke, Billig & Czaja,  
PLLC

(57) **CLAIM**

We claim the ornamental design for a writing instrument, as  
shown and described.

**DESCRIPTION**

FIG. 1 is a perspective view of a writing instrument showing  
our new design;  
FIG. 2 is a front view of FIG. 1;  
FIG. 3 is a back view of FIG. 1;  
FIG. 4 is a left side view of FIG. 1, the right side view being  
a mirror image of the right side view;  
FIG. 5 is an enlarged top view of FIG. 1; and,  
FIG. 6 is an enlarged bottom view of FIG. 1.  
The broken lines in the drawings of FIGS. 1-6 are included for  
the purpose of showing portions that form no part of the  
claimed design.

**1 Claim, 4 Drawing Sheets**

(56) **References Cited**

**U.S. PATENT DOCUMENTS**

- D496,688 S \* 9/2004 Nishida ..... D19/172
- D535,695 S \* 1/2007 Chen ..... D19/172
- D622,317 S \* 8/2010 Li ..... D19/172

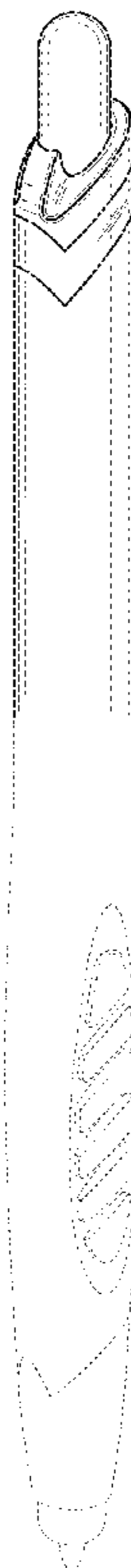

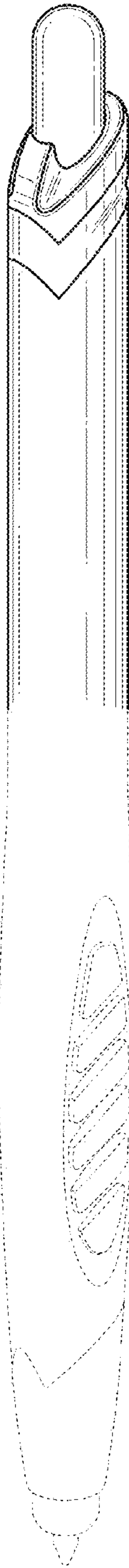
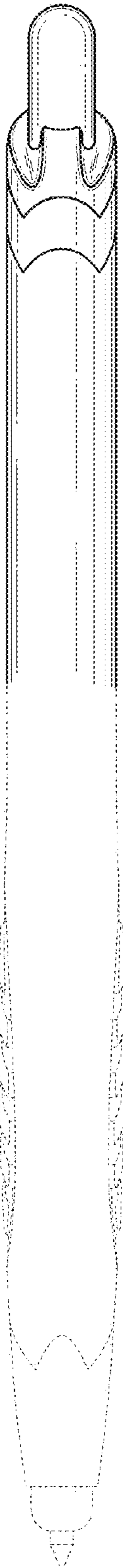
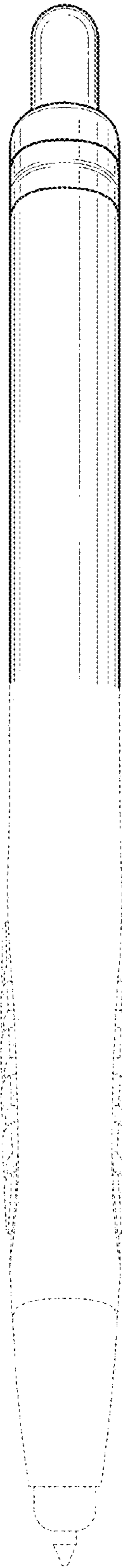

Fig. 1



**Fig. 2**



**Fig. 3**

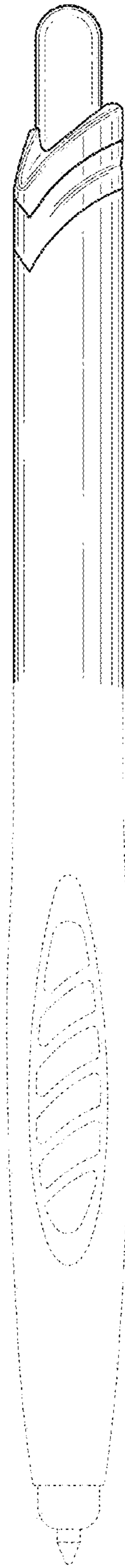
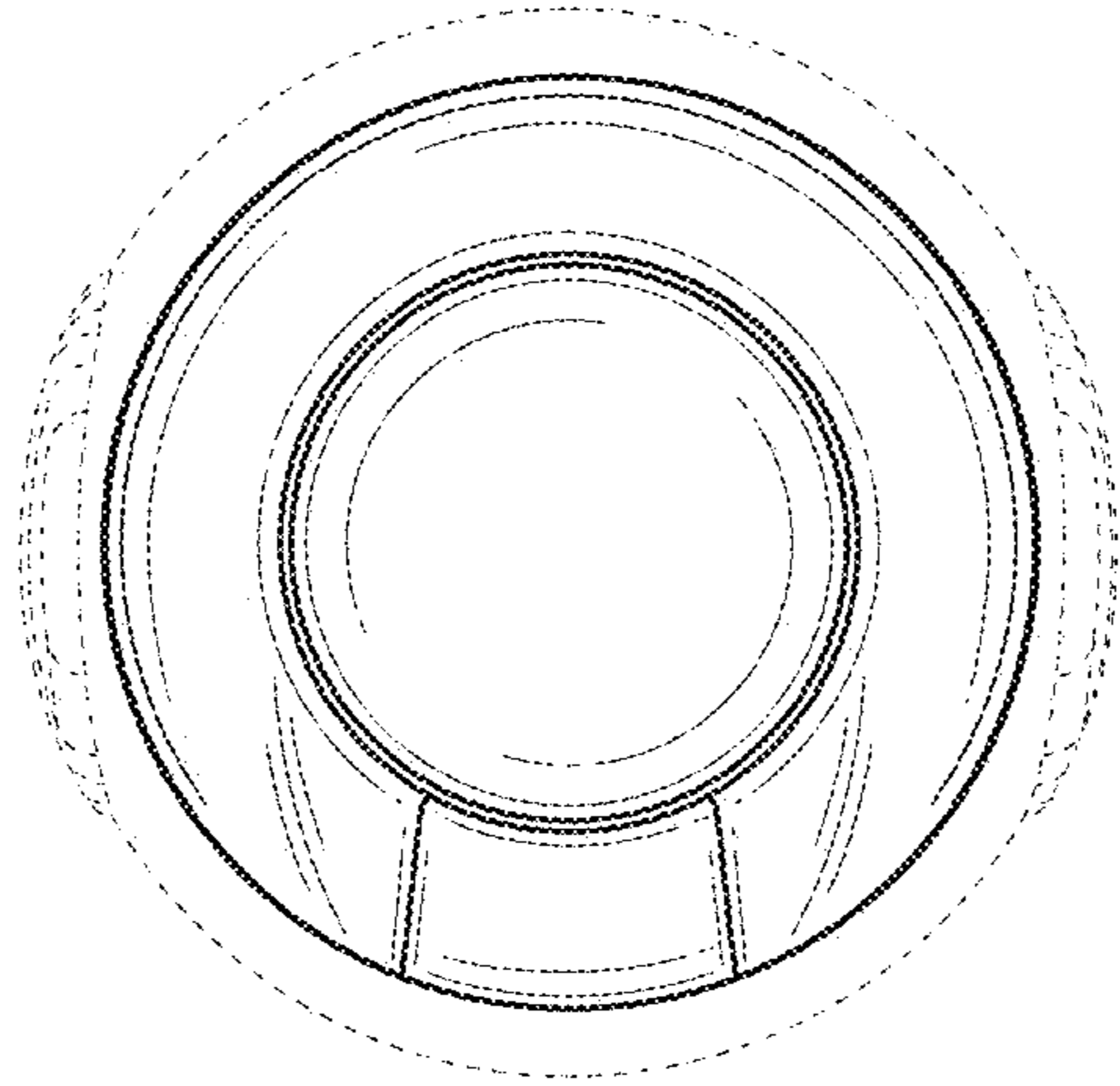
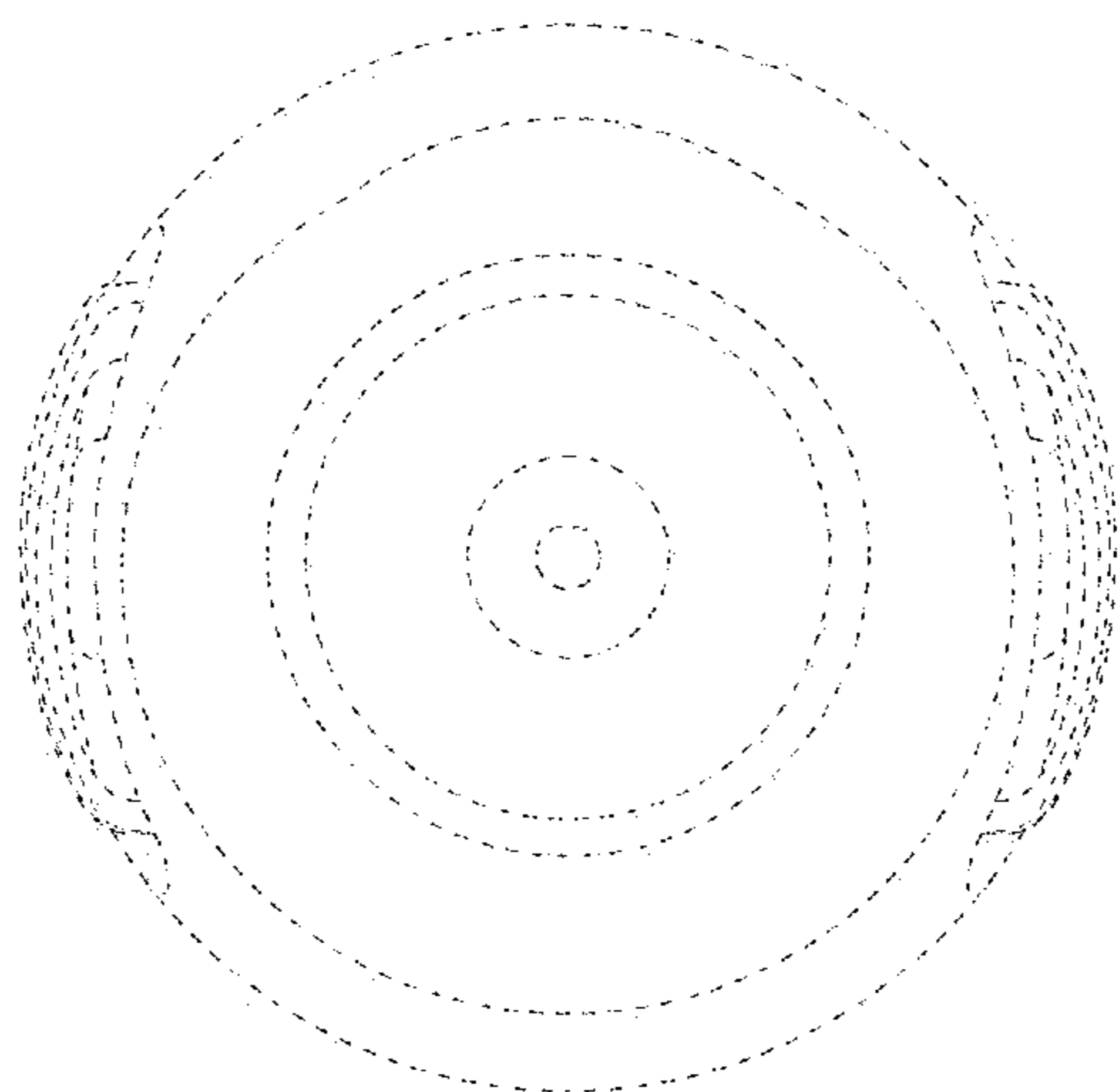

Fig. 4



**Fig. 5**



**Fig. 6**