



US00D751044S

(12) **United States Design Patent**
Maynard

(10) **Patent No.:** **US D751,044 S**
(45) **Date of Patent:** **** Mar. 8, 2016**

- (54) **CONTROL SWITCH FOR AN ELECTRONIC DEVICE**
- (71) Applicant: **HzO, Inc.**, Draper, UT (US)
- (72) Inventor: **Jason Maynard**, Salt Lake City, UT (US)
- (73) Assignee: **HZO, INC.**, Draper, UT (US)
- (**) Term: **14 Years**
- (21) Appl. No.: **29/491,613**
- (22) Filed: **May 22, 2014**
- (51) **LOC (10) Cl.** **13-03**
- (52) **U.S. Cl.**
USPC **D13/174; D13/158**
- (58) **Field of Classification Search**
USPC D13/168, 171, 173, 174; D14/218, 247, D14/138 AA, 138 G
CPC H01H 3/022; H01H 3/12; H01H 3/122; H01H 9/0235; H01H 13/023; H01H 13/04; H01H 13/14; H01H 13/86; H01H 3/142; H01H 21/22; H01H 57/00; H01H 2057/006; H01H 2201/02; H01H 2003/007; H01H 2003/008; H03K 17/964; H01L 41/08; H01L 41/09; H04M 1/236
See application file for complete search history.

(56) **References Cited**
U.S. PATENT DOCUMENTS

3,694,600	A *	9/1972	Koenig	200/86 R
3,732,384	A *	5/1973	Fischel	200/86 R
3,751,615	A *	8/1973	De Loisy	200/86 R
3,894,206	A *	7/1975	Suzuki et al.	200/85 A
3,911,241	A *	10/1975	Jarrard	200/517
4,221,975	A *	9/1980	Ledniczki et al.	307/116
4,565,910	A *	1/1986	Musick et al.	200/85 R
4,845,323	A *	7/1989	Beggs	200/85 R
D307,579	S *	5/1990	Layne et al.	D13/137.3

4,987,277	A *	1/1991	Duhon	200/86 R
5,118,910	A *	6/1992	Duhon et al.	200/86 R
5,608,282	A *	3/1997	Wilber et al.	505/211
5,967,299	A *	10/1999	de Richecour et al.	200/512
D418,144	S *	12/1999	Allen et al.	D14/456
6,009,970	A *	1/2000	Breed	180/274
D420,677	S *	2/2000	Kolinen	D14/247
6,172,315	B1 *	1/2001	Miller et al.	200/61.73
6,453,086	B1 *	9/2002	Tarazona	385/20
6,750,594	B2 *	6/2004	Wong	310/328
D520,464	S *	5/2006	Strong et al.	D13/171
D559,197	S *	1/2008	Lim et al.	D13/162
D567,185	S *	4/2008	Mayo et al.	D13/158
D582,354	S *	12/2008	Andre et al.	D13/158
7,464,605	B2 *	12/2008	Douglas et al.	73/795
D596,640	S *	7/2009	Leung et al.	D14/456
D597,071	S *	7/2009	Andre et al.	D14/206
D601,976	S *	10/2009	Petrillo et al.	D13/168
D606,980	S *	12/2009	Bradford	D14/218
D614,166	S *	4/2010	Brickstad	D14/205
7,821,415	B1 *	10/2010	Kimberlin	340/666

(Continued)

Primary Examiner — Selina Sikder
(74) *Attorney, Agent, or Firm* — Foley Hoag LLP; Walter M. Egbert, III; Stephen Kenny

(57) **CLAIM**
The ornamental design for a control switch for an electronic device, as shown and described.

DESCRIPTION

FIG. 1 is a perspective view of the control switch for an electronic device showing my new design;
FIG. 2 is a top view thereof;
FIG. 3 is a bottom view thereof;
FIG. 4 is a first side view thereof;
FIG. 5 second side view thereof;
FIG. 6 is a first end view thereof; and,
FIG. 7 is a second end view thereof.
Broken lines are used in the drawings to illustrate features that form no part of the claimed design.

1 Claim, 1 Drawing Sheet

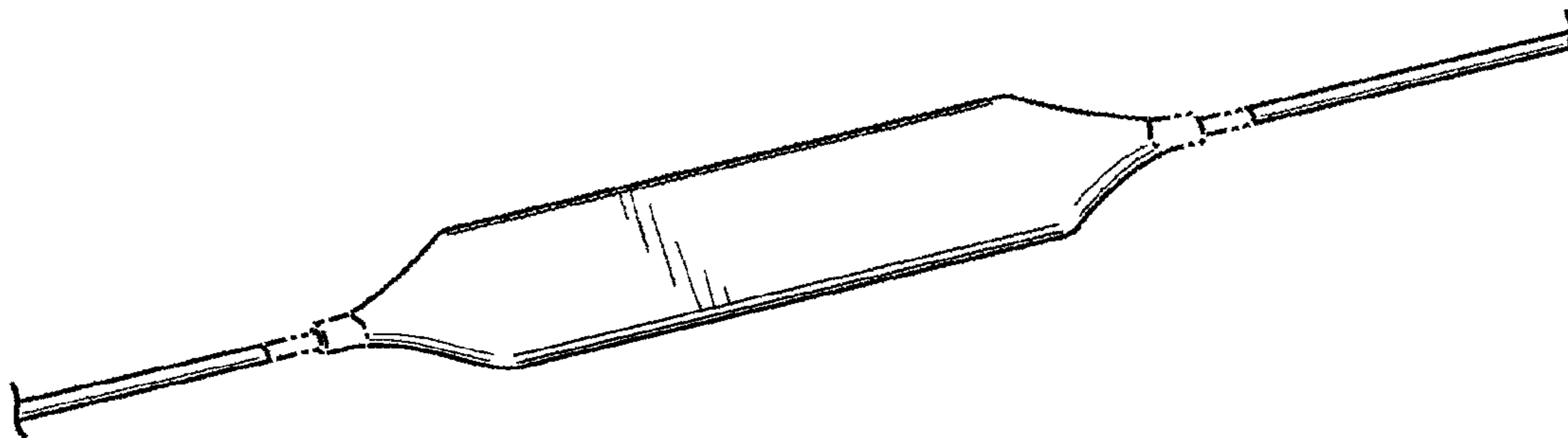

(56)

References Cited

U.S. PATENT DOCUMENTS

D626,921 S *	11/2010	Pang	D13/158	D722,034 S *	2/2015	Lee et al.	D14/138 G
D633,447 S *	3/2011	Schaal et al.	D13/168	D722,583 S *	2/2015	Kim et al.	D14/138 G
7,920,903 B2 *	4/2011	Ueda et al.	455/575.1	D726,130 S *	4/2015	Burgett et al.	D13/171
D646,640 S *	10/2011	Clymer et al.	D13/160	9,117,350 B2 *	8/2015	Chi et al.		
D654,879 S *	2/2012	Li et al.	D13/170	2004/0144635 A1 *	7/2004	Fitzgerald et al.	200/512
D668,629 S *	10/2012	Chung	D14/138 G	2009/0289736 A1 *	11/2009	Xi et al.	333/105
D685,750 S *	7/2013	Nakagawa	D13/168	2009/0294263 A1 *	12/2009	De Vries et al.	200/181
8,504,115 B2 *	8/2013	Junge et al.	455/569.1	2010/0060110 A1 *	3/2010	Inagaki et al.	310/366
D689,445 S *	9/2013	Chu	D13/174	2010/0141580 A1 *	6/2010	Oh	345/158
8,525,387 B2 *	9/2013	Kamijo et al.	310/323.02	2011/0148251 A1 *	6/2011	Piazza et al.	310/317
D709,055 S *	7/2014	Cho	D14/247	2012/0187211 A1 *	7/2012	Nakamura	239/102.2
D714,243 S *	9/2014	Dhondt	D14/138 G	2014/0253477 A1 *	9/2014	Shim et al.	345/173
					2015/0155470 A1 *	6/2015	Mori	310/326
					2015/0248209 A1 *	9/2015	Kim et al.	345/173

* cited by examiner

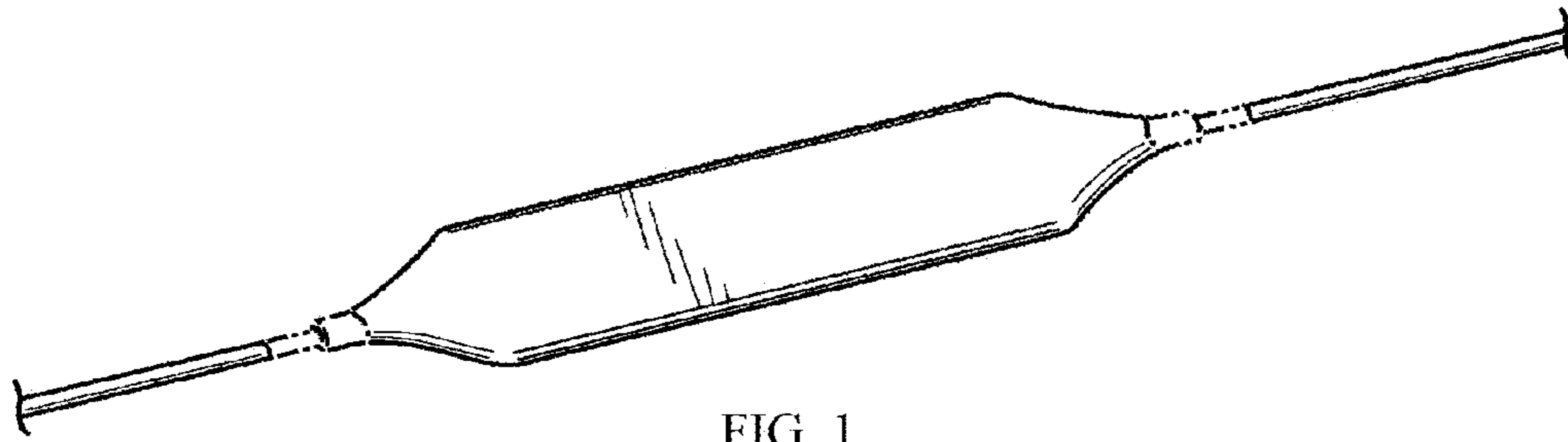

FIG. 1

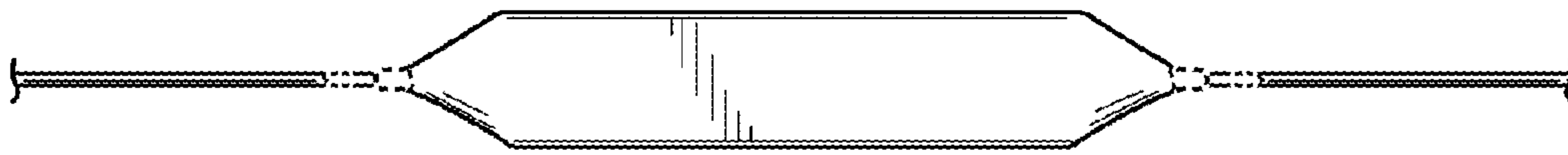

FIG. 2

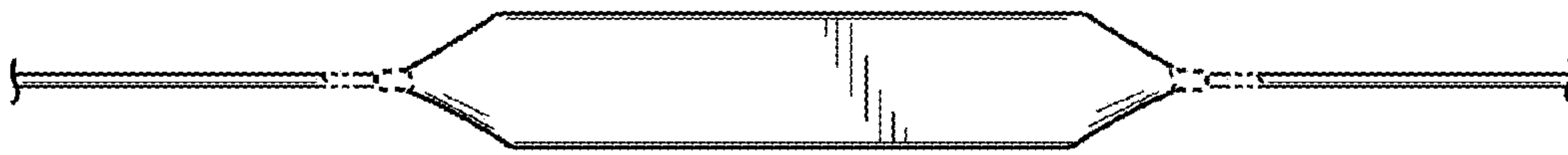

FIG. 3

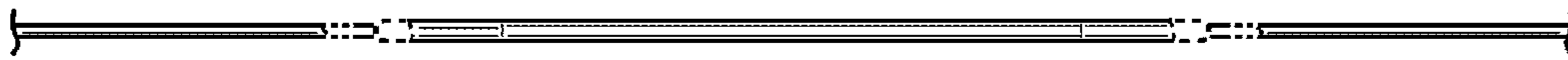

FIG. 4

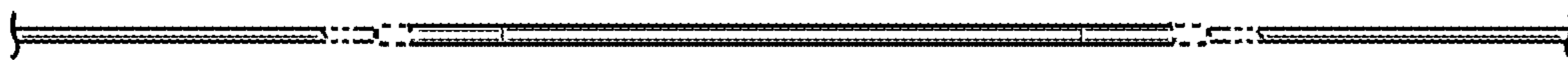

FIG. 5



FIG. 6



FIG. 7