



US00D750746S

(12) **United States Design Patent**
McLauchlan et al.

(10) **Patent No.:** **US D750,746 S**
(45) **Date of Patent:** **** Mar. 1, 2016**

- (54) **FUEL TANK ISOLATION VALVE**
- (71) Applicant: **Eaton Corporation**, Cleveland, OH (US)
- (72) Inventors: **Raymond Bruce McLauchlan**, Macomb Township, MI (US); **Vaughn Kevin Mills**, Chelsea, MI (US); **Ronald Earl Sexton**, South Lyon, MI (US); **Steven Lee Ambrose**, Farmington Hills, MI (US); **Robert Dean Keller**, Davisburg, MI (US); **Daniel Lee Pifer**, Chelsea, MI (US)
- (73) Assignee: **Eaton Corporation**, Cleveland, OH (US)
- (**) Term: **14 Years**
- (21) Appl. No.: **29/521,331**
- (22) Filed: **Mar. 23, 2015**

Related U.S. Application Data

- (60) Division of application No. 29/486,902, filed on Apr. 3, 2014, now Pat. No. Des. 728,747, which is a division of application No. 29/412,051, filed on Jan. 30, 2012, now Pat. No. Des. 706,390, which is a
(Continued)

- (51) **LOC (10) Cl.** **23-01**
- (52) **U.S. Cl.**
USPC **D23/233**
- (58) **Field of Classification Search**
USPC D23/233-237, 244-249; 192/87.13, 192/3.57, 87.18; 251/129.01, 137, 282, 251/324-325, 321, 355, 129.08, 129.07; 137/398, 545, 547, 549, 556.3, 553, 137/556.6, 625.65, 625.25
CPC F16K 21/04; F16K 21/16; F16K 11/166; F16K 1/523

See application file for complete search history.

- (56) **References Cited**
U.S. PATENT DOCUMENTS
4,192,346 A 3/1980 Iizumi
4,227,674 A * 10/1980 Grant, Jr. F16K 21/16
251/15

(Continued)

FOREIGN PATENT DOCUMENTS

- EP 0713036 A1 5/1996
- EP 2071217 A1 6/2009

(Continued)

OTHER PUBLICATIONS

U.S. Appl. No. 29/521,329, filed Mar. 23, 2015, to McLauchlan et al., preliminary amendment, replacement drawing sheets, and application body as-filed.

(Continued)

Primary Examiner — Cynthia Ramirez

(74) *Attorney, Agent, or Firm* — Mei & Mark LLP

(57) **CLAIM**

The ornamental design for fuel tank isolation valve, as shown and described.

DESCRIPTION

FIG. 1 is a right side view of a fuel tank isolation valve in accordance with an aspect of the present disclosure.
 FIG. 2 is a left side view of the fuel tank isolation valve of FIG. 1.
 FIG. 3 is a top view of the valve of FIG. 1.
 FIG. 4 is a bottom view of the fuel tank isolation valve of FIG. 1.
 FIG. 5 is a front view of the fuel tank isolation valve of FIG. 1.
 FIG. 6 is a rear view of the fuel tank isolation valve of FIG. 1.
 FIG. 7 is a top right rear perspective view of the fuel tank isolation valve of FIG. 1; and,
 FIG. 8 is a bottom left front perspective view of the fuel tank isolation valve of FIG. 1.
 The broken lines showing portions of the fuel tank isolation valve form no part of the claimed design.

1 Claim, 6 Drawing Sheets

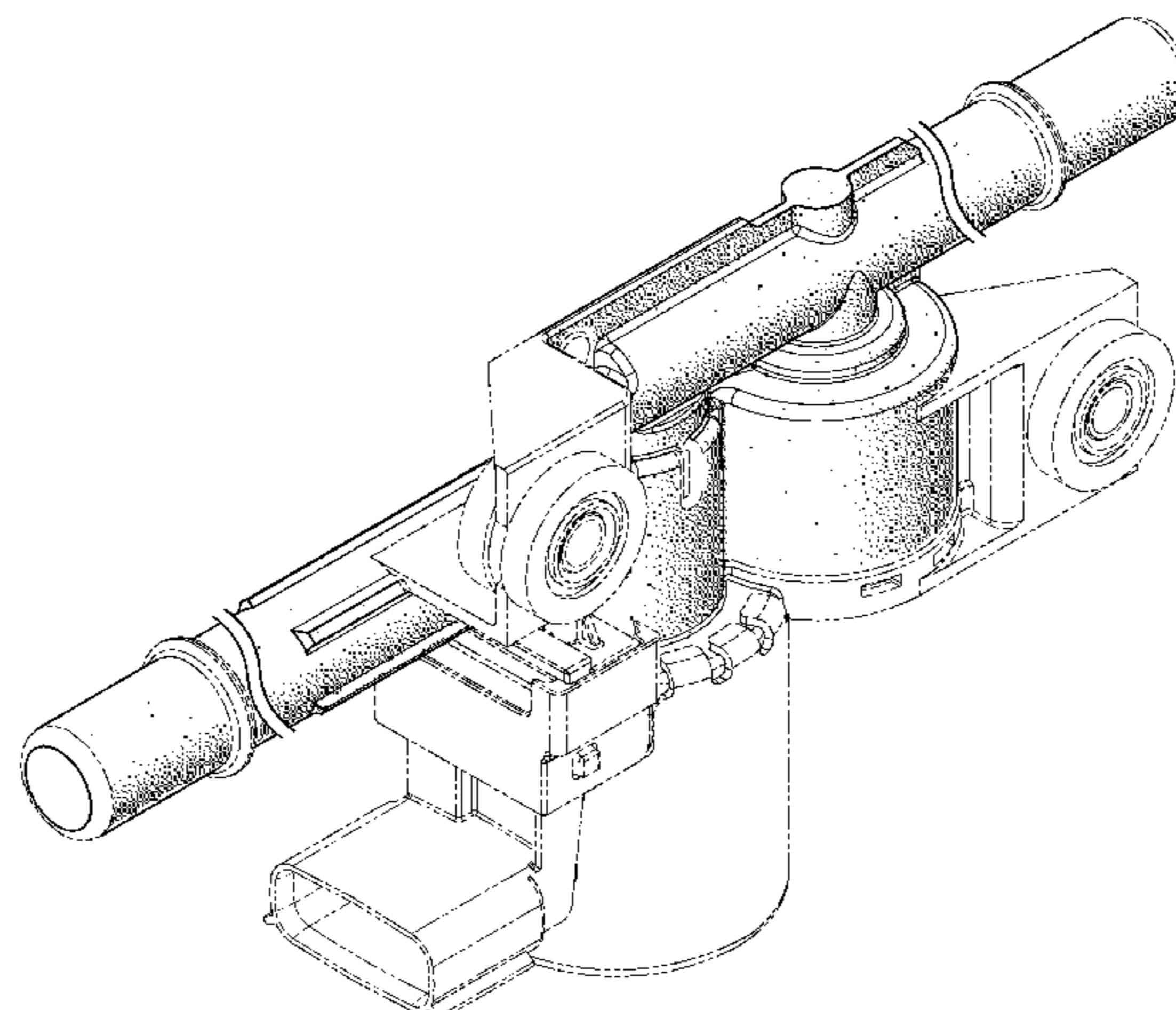

Related U.S. Application Data

continuation-in-part of application No. 29/404,911, filed on Oct. 26, 2011, now Pat. No. Des. 706,389, which is a continuation-in-part of application No. 13/011,676, filed on Jan. 21, 2011, now Pat. No. 8,573,255, which is a continuation-in-part of application No. 12/749,924, filed on Mar. 30, 2010, now Pat. No. 8,584,704.

(56)

References Cited

U.S. PATENT DOCUMENTS

4,231,542 A * 11/1980 Grenier F16K 21/04
251/15

4,364,305 A 12/1982 Dalibout et al.

4,370,983 A 2/1983 Lichtenstein

4,685,156 A * 8/1987 Brabazon F16K 1/523
137/597

4,865,078 A * 9/1989 Ensign F16K 11/166
137/636.1

4,964,677 A 10/1990 Splinter

D314,229 S * 1/1991 Nestich D23/233

5,048,790 A 9/1991 Wells

5,083,546 A 1/1992 Detweiler et al.

5,211,151 A 5/1993 Nakajima et al.

5,218,995 A * 6/1993 Lee B01D 61/10
137/557

5,406,975 A 4/1995 Nakamichi et al.

5,605,177 A 2/1997 Ohashi et al.

5,967,183 A 10/1999 Detweiler et al.

5,996,603 A * 12/1999 Dupler E03B 7/09
137/1

6,526,951 B2 3/2003 Ishigaki et al.

D502,762 S * 3/2005 Kriegshauser D23/233

6,910,745 B2 6/2005 Inage

7,152,587 B2 12/2006 Suzuki

7,267,113 B2 9/2007 Tsuge et al.

7,270,310 B2 9/2007 Takakura

7,347,192 B2 3/2008 Perry et al.

7,422,193 B2 9/2008 Sisk et al.

7,448,367 B1 11/2008 Reddy et al.

D585,959 S * 2/2009 Caron D23/233

7,591,281 B2 9/2009 Tsuge

D621,003 S * 8/2010 Gramegna D23/233

7,828,265 B2 11/2010 Sisk et al.

D686,699 S 7/2013 Evans et al.

8,573,255 B2 11/2013 Pifer et al.

8,584,704 B2 11/2013 Pifer et al.

D706,389 S 6/2014 McLauchlan et al.

D706,390 S * 6/2014 McLauchlan D23/233

D728,746 S 5/2015 McLauchlan et al.

D728,747 S * 5/2015 McLauchlan D23/233

2001/0017160 A1 8/2001 Ishigaki et al.

2005/0181647 A1 8/2005 Dehnen et al.

2005/0217734 A1 10/2005 Takakura

2006/0207663 A1 9/2006 Tsuge

2008/0042086 A1 2/2008 Sisk et al.

2010/0269921 A1 10/2010 Pifer et al.

2011/0240145 A1 10/2011 Pifer

FOREIGN PATENT DOCUMENTS

JP S593071 U 1/1984

JP H01173579 U 12/1989

JP H04105959 U 9/1992

JP H0669544 U 9/1994

JP H0771335 A 3/1995

JP 2001099015 A 4/2001

JP 2006258135 A 9/2006

JP 2008513651 A 5/2008

WO 0190611 A2 11/2001

WO 2006029537 3/2006

OTHER PUBLICATIONS

Yojiro Iriyama, Masahide Kobayashi, Takuji Matsubara < Yuusaku Nishimura, Ryosuke Nomura, and Takashi Ishikawa, "Design of a Fuel Vapor-containment System (FVS) to Meet Zero Evaporative Emissions Requirements in a Hybrid Electric Vehicle", SAE international, 2005-01-3825, 2005, pp. 1-8.

International Search Report and Written Opinion dated Jul. 6, 2012 for PCT application No. PCT/US2012/021876 filed Jan. 19, 2012, pp. 1-12.

International Search Report and Written Opinion issued in Application No. PCT/IB2012/000079. Date of Mailing: Jul. 26, 2012, pp. 1-13.

* cited by examiner

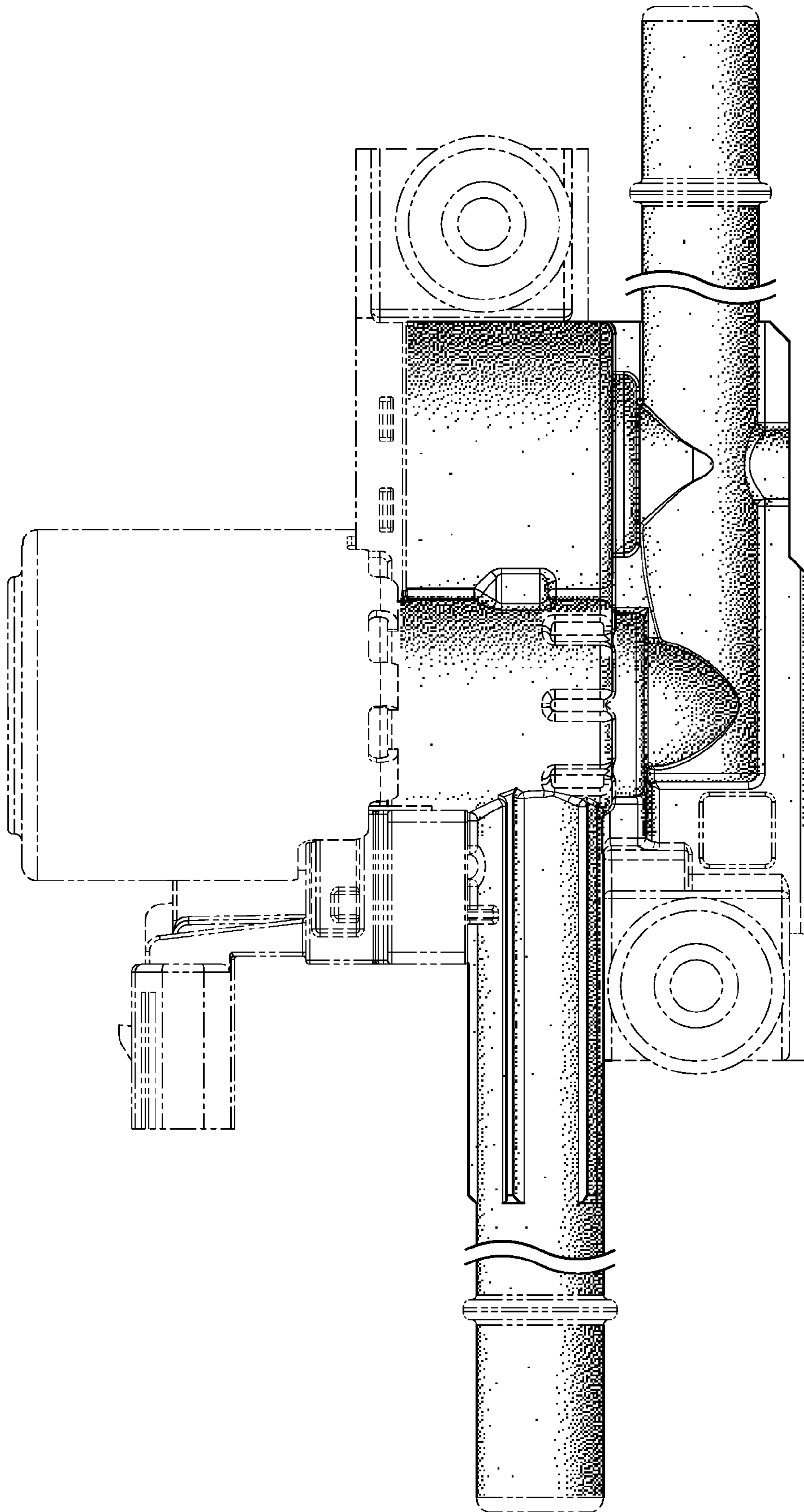

FIG. 1

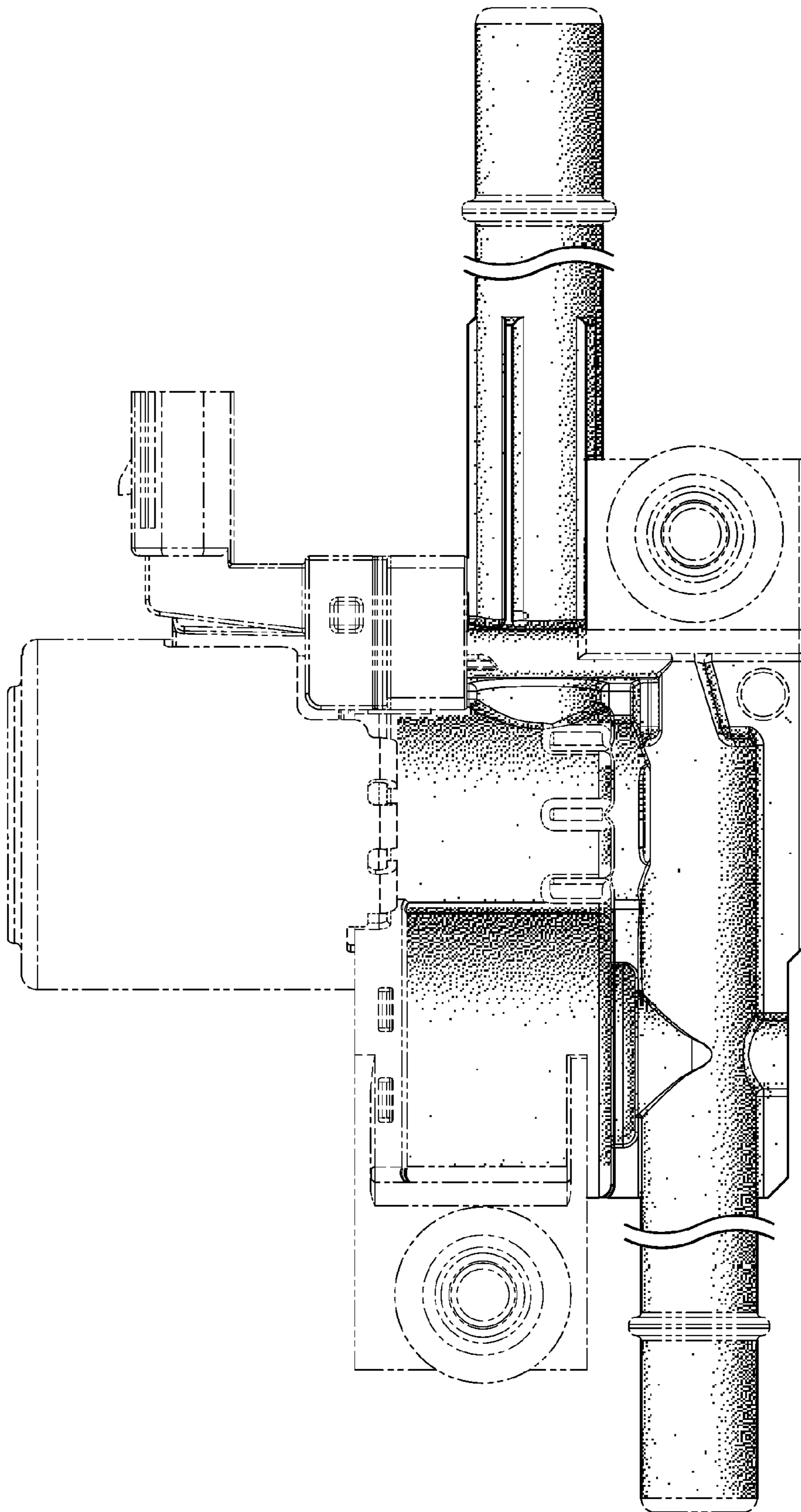

FIG. 2

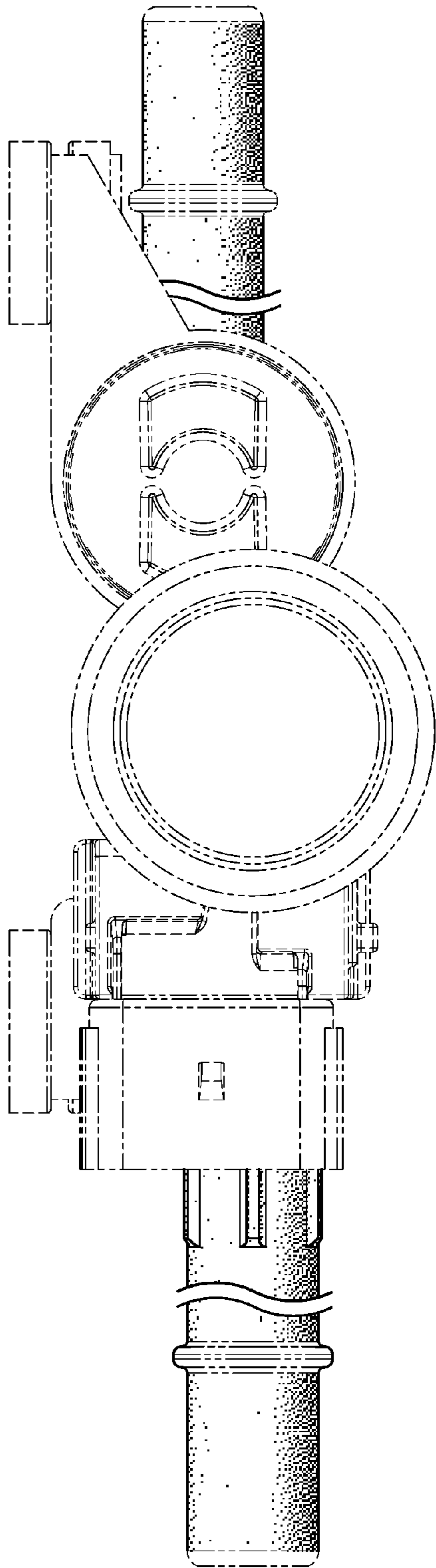

FIG. 3

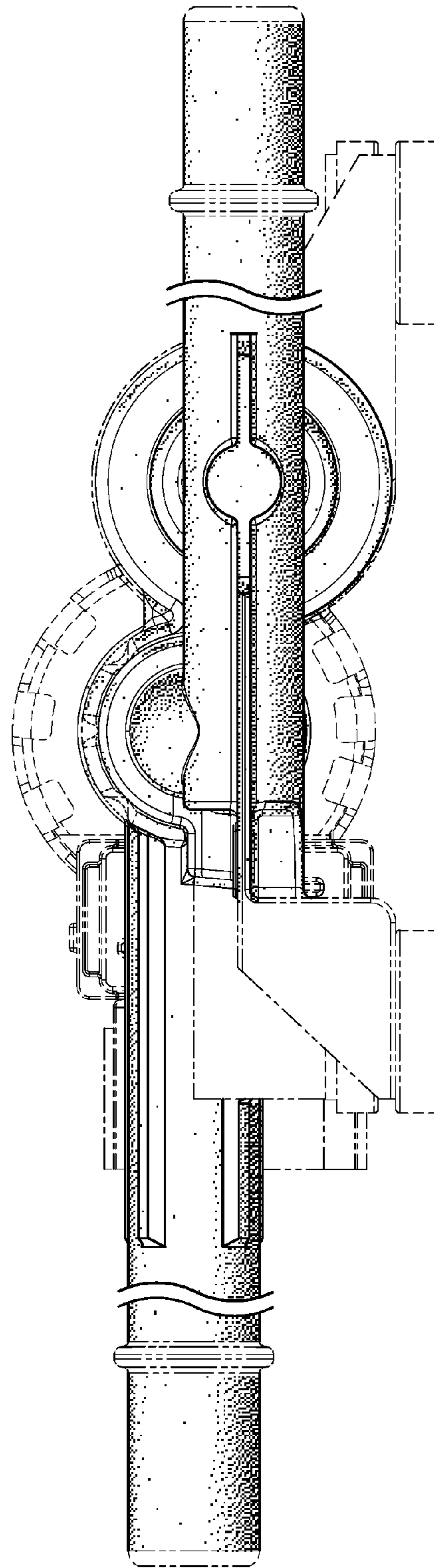

FIG. 4

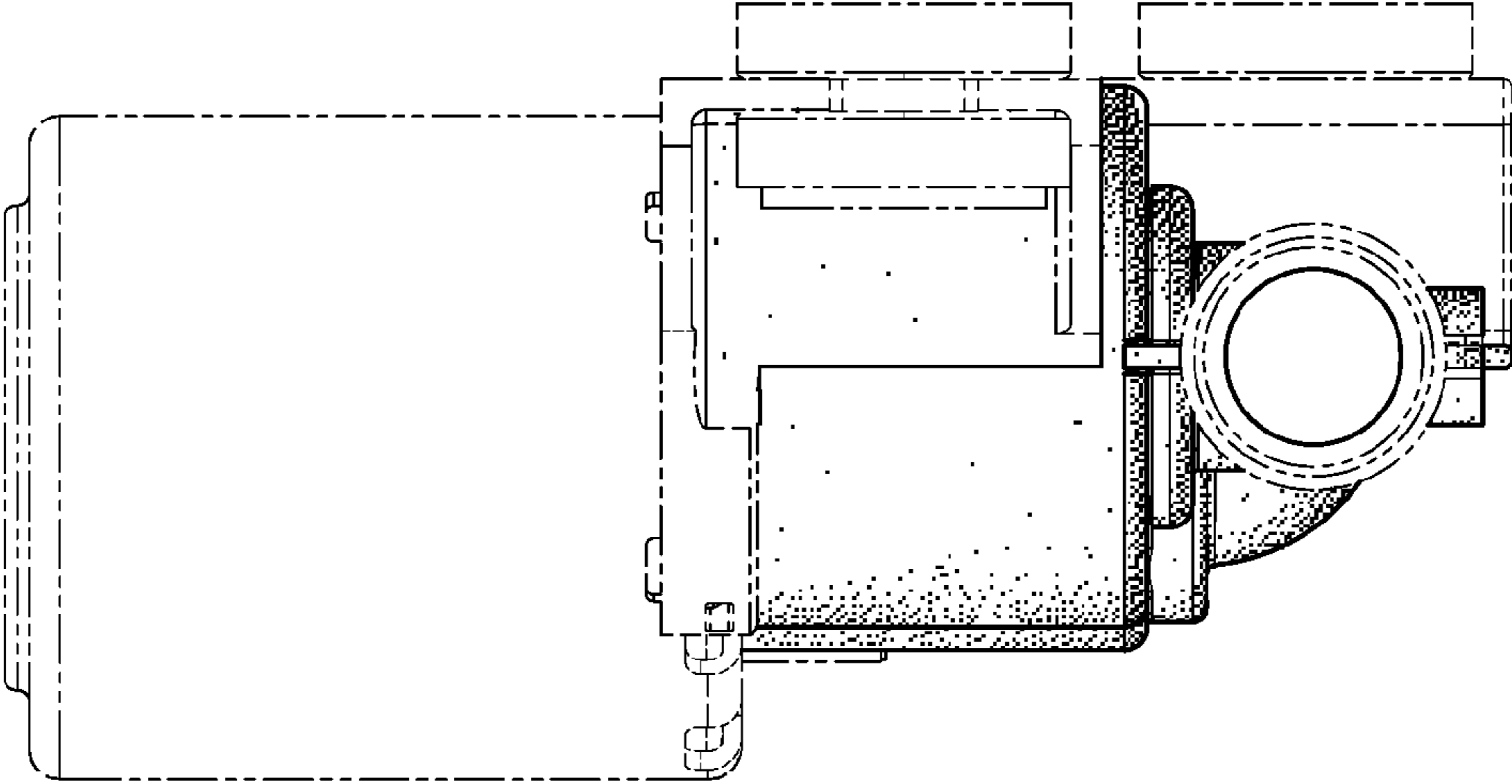

FIG. 6

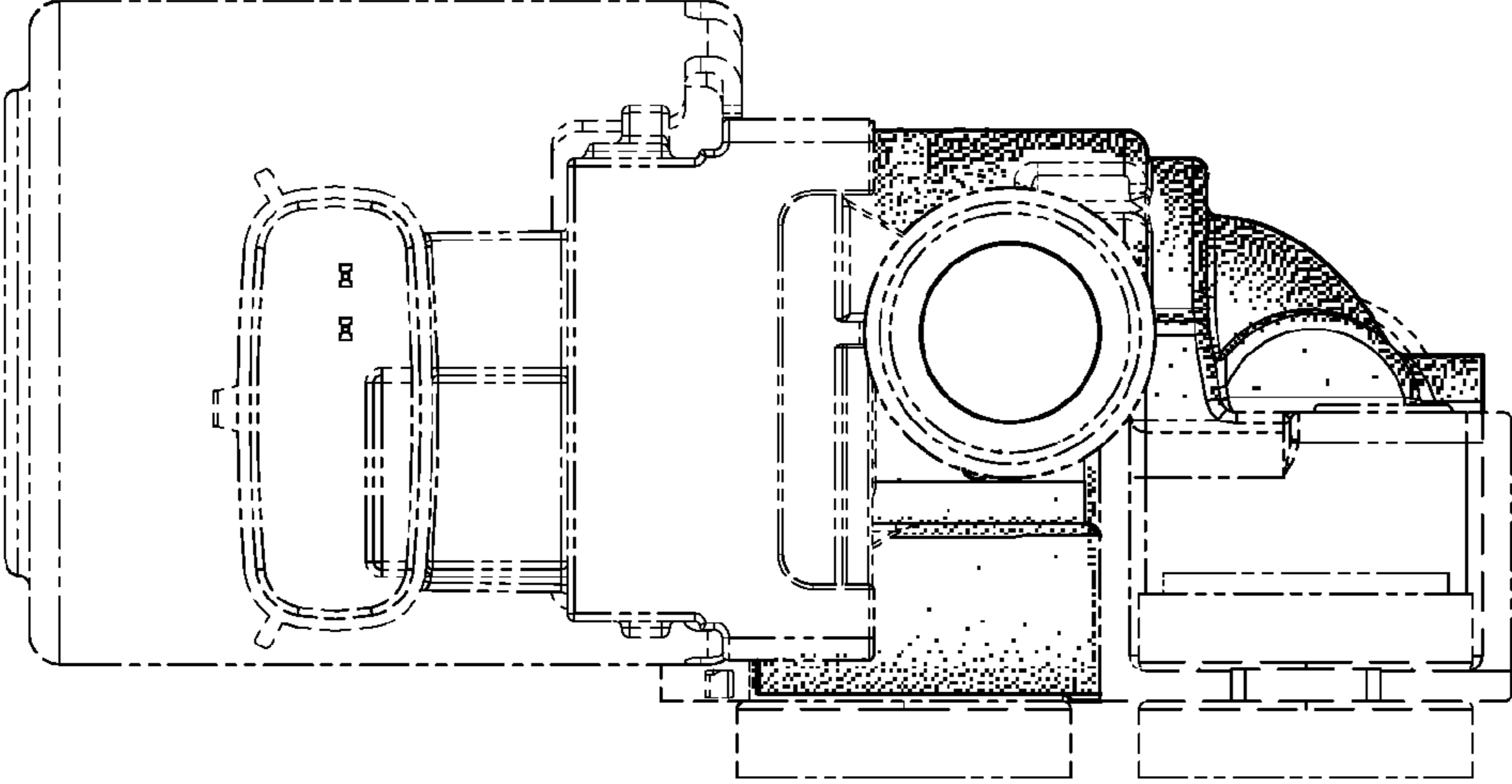

FIG. 5

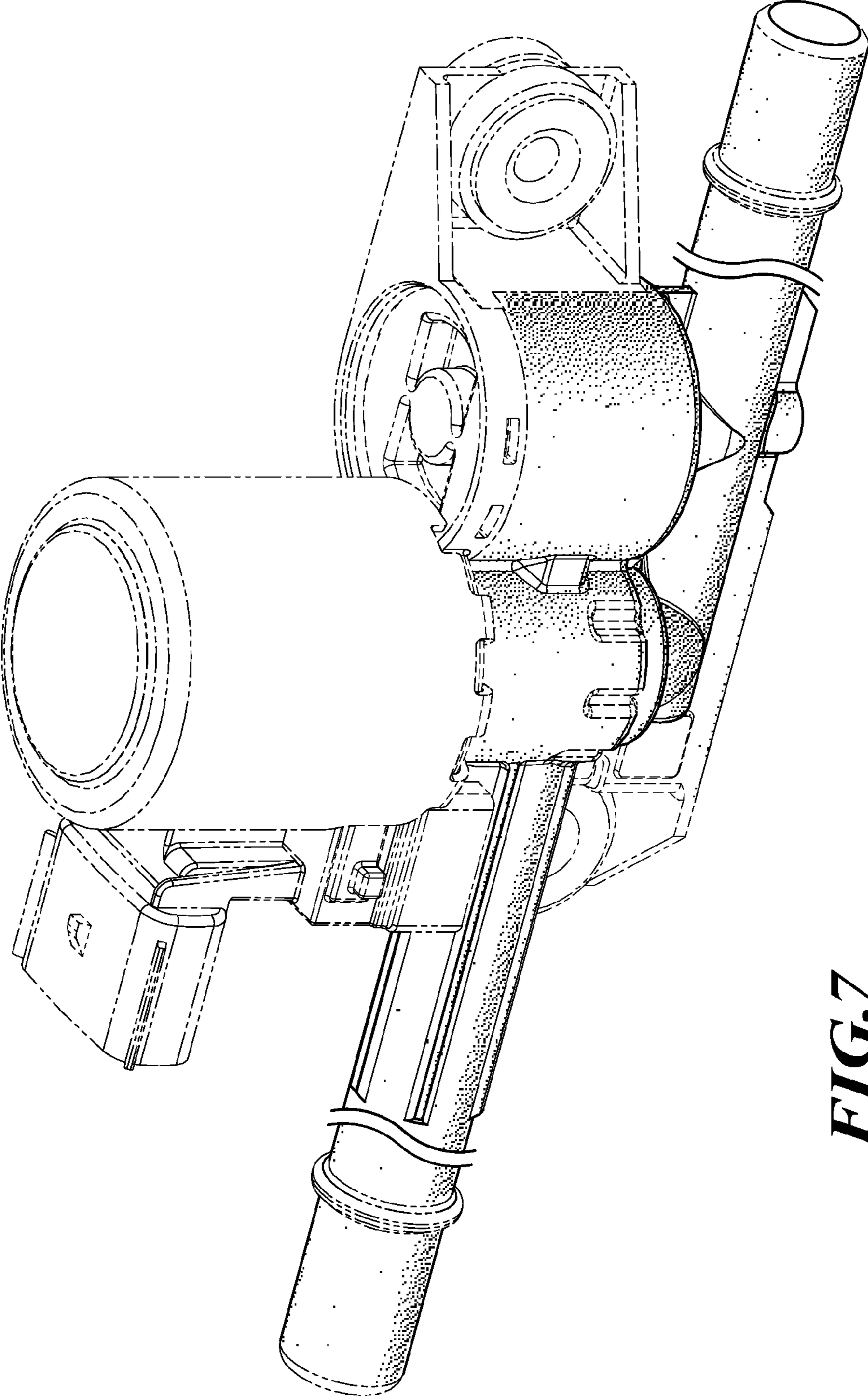

FIG. 7

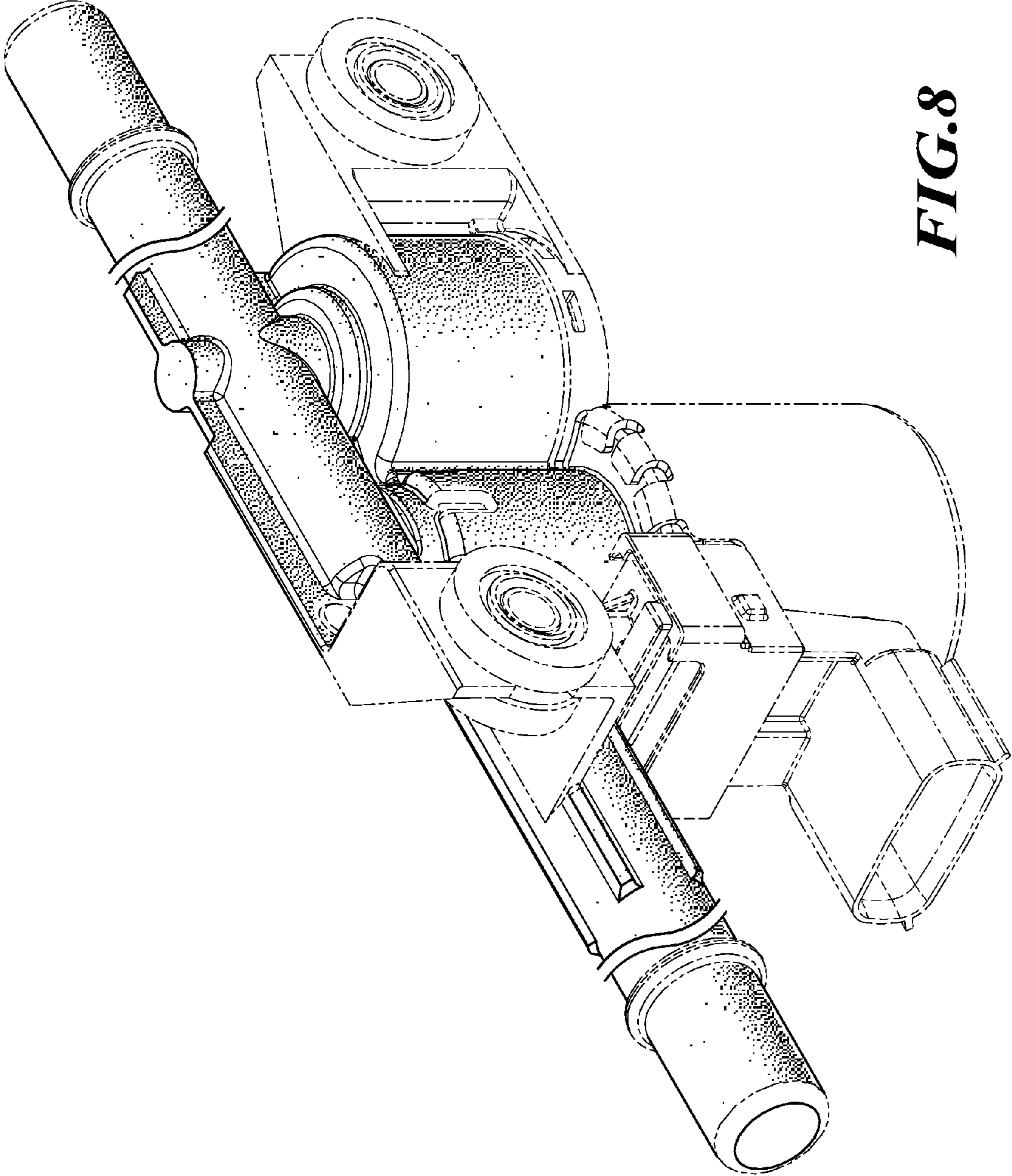

FIG.8