



US00D750675S

(12) **United States Design Patent**
Fagerberg et al.

(10) **Patent No.:** **US D750,675 S**
(45) **Date of Patent:** **** Mar. 1, 2016**

- (54) **PRESSURE SEALING MEANS FOR CABLE TRANSIT**
- (71) Applicants: **Johan Fagerberg**, Karlskrona (SE);
Anders Karlsson, Fågelmara (SE)
- (72) Inventors: **Johan Fagerberg**, Karlskrona (SE);
Anders Karlsson, Fågelmara (SE)
- (73) Assignee: **MCT Brattberg AB**, Karlskrona (SE)
- (**) Term: **14 Years**
- (21) Appl. No.: **29/508,525**
- (22) Filed: **Nov. 7, 2014**
- (30) **Foreign Application Priority Data**
May 7, 2014 (EP) 002459057
- (51) **LOC (10) CL.** **15-99**
- (52) **U.S. CL.**
USPC **D15/146**
- (58) **Field of Classification Search**
USPC D15/145, 146
See application file for complete search history.

(56) **References Cited**

U.S. PATENT DOCUMENTS

- D253,894 S * 1/1980 Lombardi D15/146
- D280,515 S * 9/1985 Minney D15/146
- D339,362 S * 9/1993 Hoover D15/146
- D340,937 S * 11/1993 Seger D15/146
- 5,416,271 A * 5/1995 Birmingham F16L 5/08
174/657
- 5,442,140 A * 8/1995 Mc Grane F16L 5/10
174/151
- D372,488 S * 8/1996 Linner D15/146
- D385,894 S * 11/1997 Linner D15/146
- 5,783,776 A * 7/1998 Birmingham F16L 5/08
174/657
- D411,554 S * 6/1999 Lee D15/146
- 5,939,676 A * 8/1999 Birmingham F16L 5/08
174/656
- 6,083,035 A * 7/2000 Mackey H01R 4/2408
439/410
- D454,894 S * 3/2002 Chou D15/146
- 6,888,067 B1 * 5/2005 Howland H01R 13/5208
174/74 R

- 7,087,838 B2 * 8/2006 Ferderer H01R 13/5205
174/153 G
- D528,137 S * 9/2006 Huang D15/146
- 7,355,130 B2 * 4/2008 Holman H02G 3/088
16/2.1
- D618,716 S * 6/2010 Huang D15/146
- 8,096,562 B2 * 1/2012 Johansson F16L 5/08
174/40 CC
- 8,125,784 B2 * 2/2012 Jiao H02G 15/013
361/728
- 8,378,239 B2 * 2/2013 Lakner G11B 33/123
174/152 GM
- 8,852,477 B2 * 10/2014 Satou H02G 3/22
361/728
- 8,853,537 B2 * 10/2014 Kempeneers G02B 6/4465
174/74 R
- 8,917,967 B2 * 12/2014 Kempeneers G02B 6/4471
385/139
- 8,981,229 B2 * 3/2015 Larsson H02G 3/22
16/2.1
- D727,382 S * 4/2015 Jenkins D15/146
- 9,048,563 B2 * 6/2015 Miura H01R 12/81
- 9,118,171 B2 * 8/2015 Blakemore F23M 11/045
- 9,142,946 B2 * 9/2015 Krager H02G 3/32

* cited by examiner

Primary Examiner — Patricia Palasik

(74) *Attorney, Agent, or Firm* — Cooper Legal Group, LLC

(57) **CLAIM**

The ornamental design for a pressure sealing means for cable transit, as shown and described.

DESCRIPTION

FIG. 1 is a first perspective view of the pressure sealing means for cable transit;
 FIG. 2 is a second perspective view of the pressure sealing means for cable transit;
 FIG. 3 is a front view of the pressure sealing means for cable transit;
 FIG. 4 is a rear view of the pressure sealing means for cable transit;
 FIG. 5 is a side view of the pressure sealing means for cable transit;
 FIG. 6 is a top view of the pressure sealing means for cable transit; and,
 FIG. 7 is a bottom view of the pressure sealing means for cable transit.

1 Claim, 7 Drawing Sheets

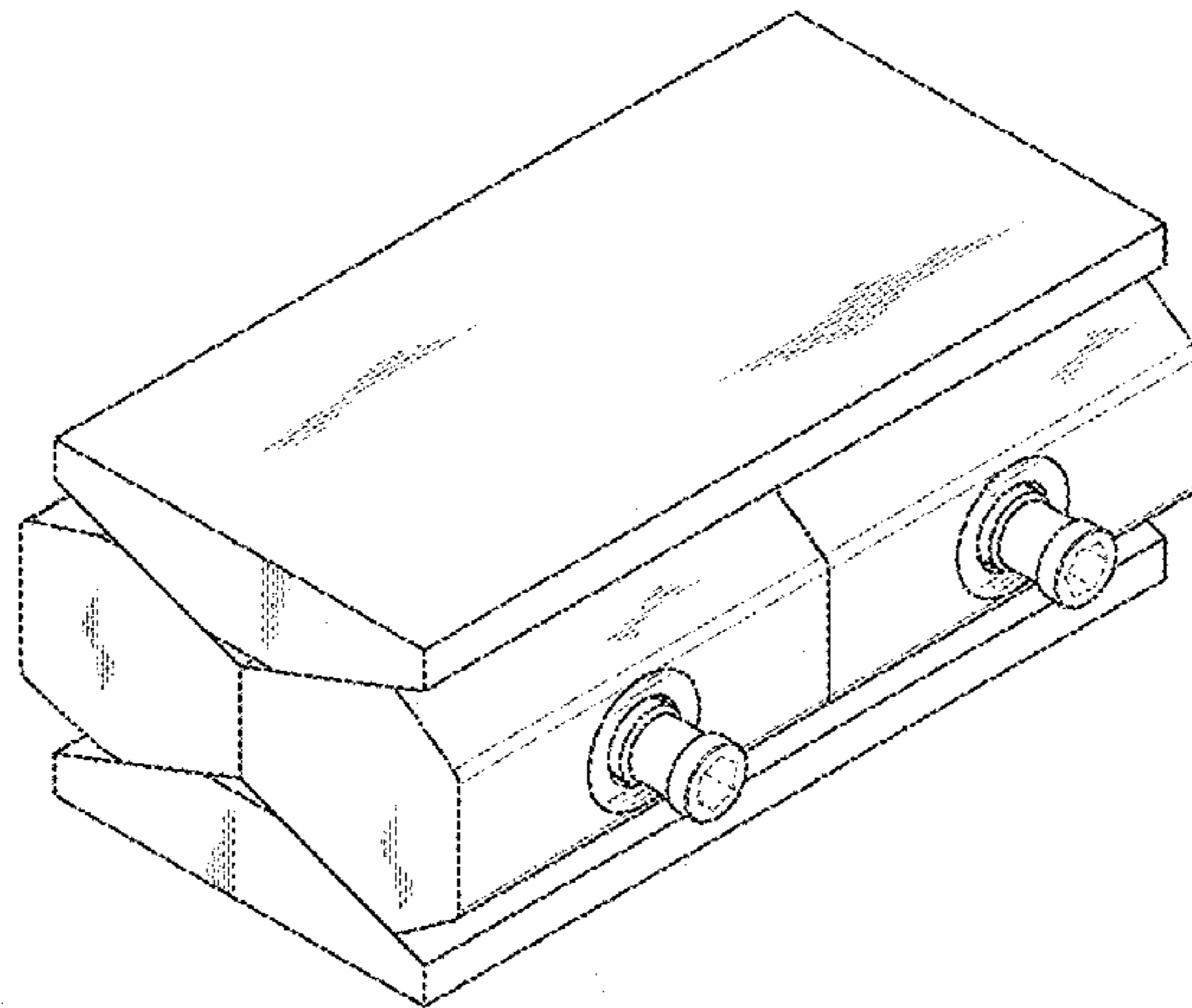

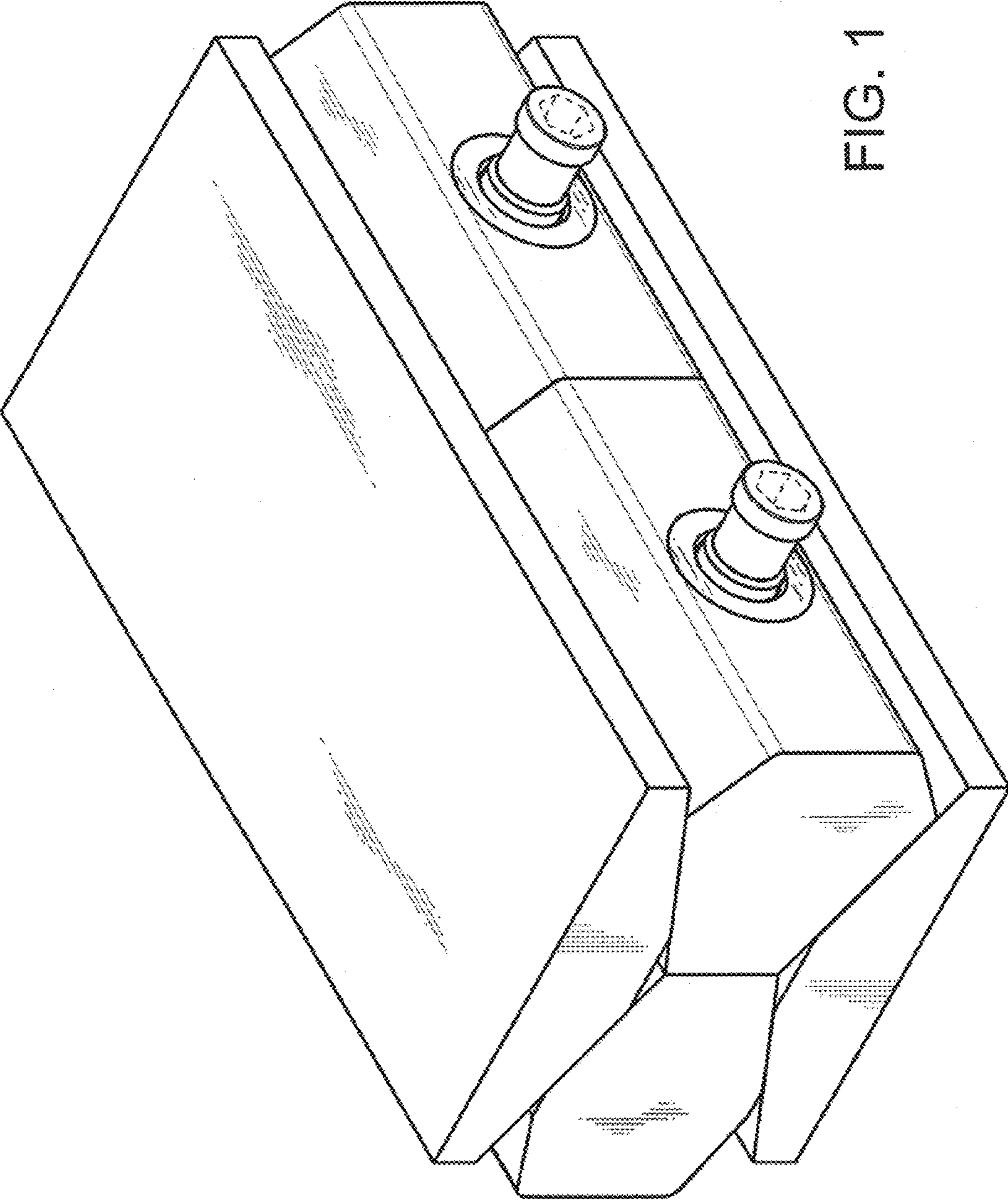

FIG. 1

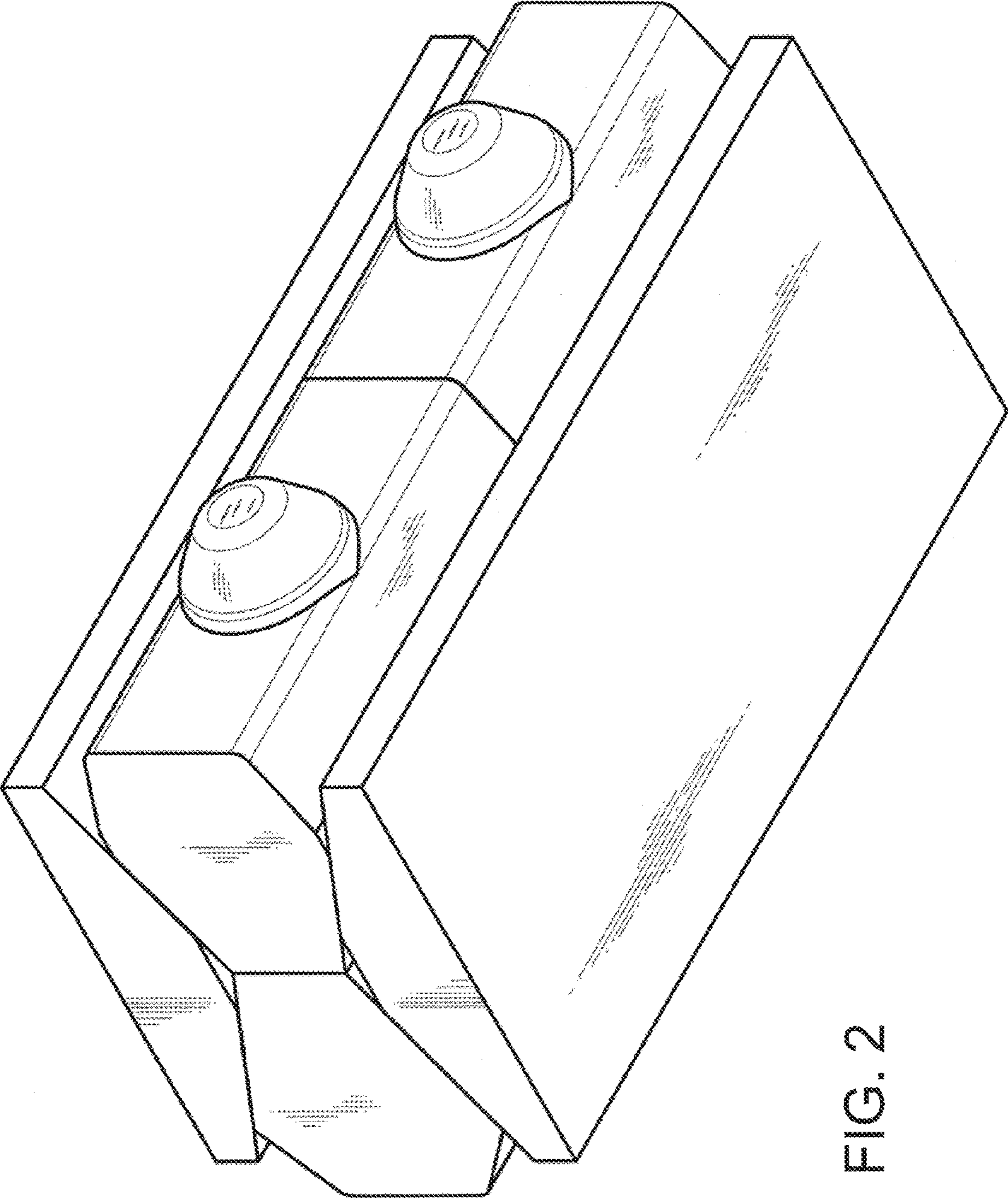

FIG. 2

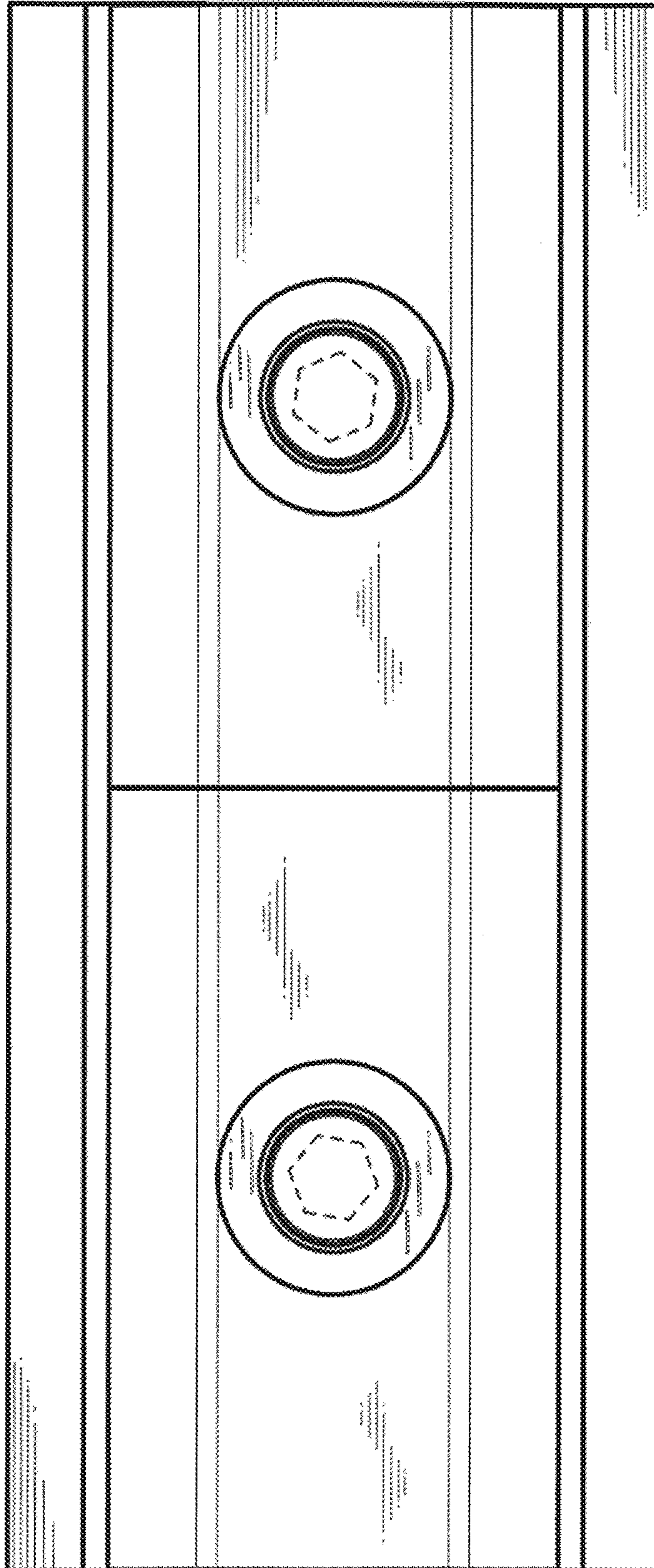

FIG. 3

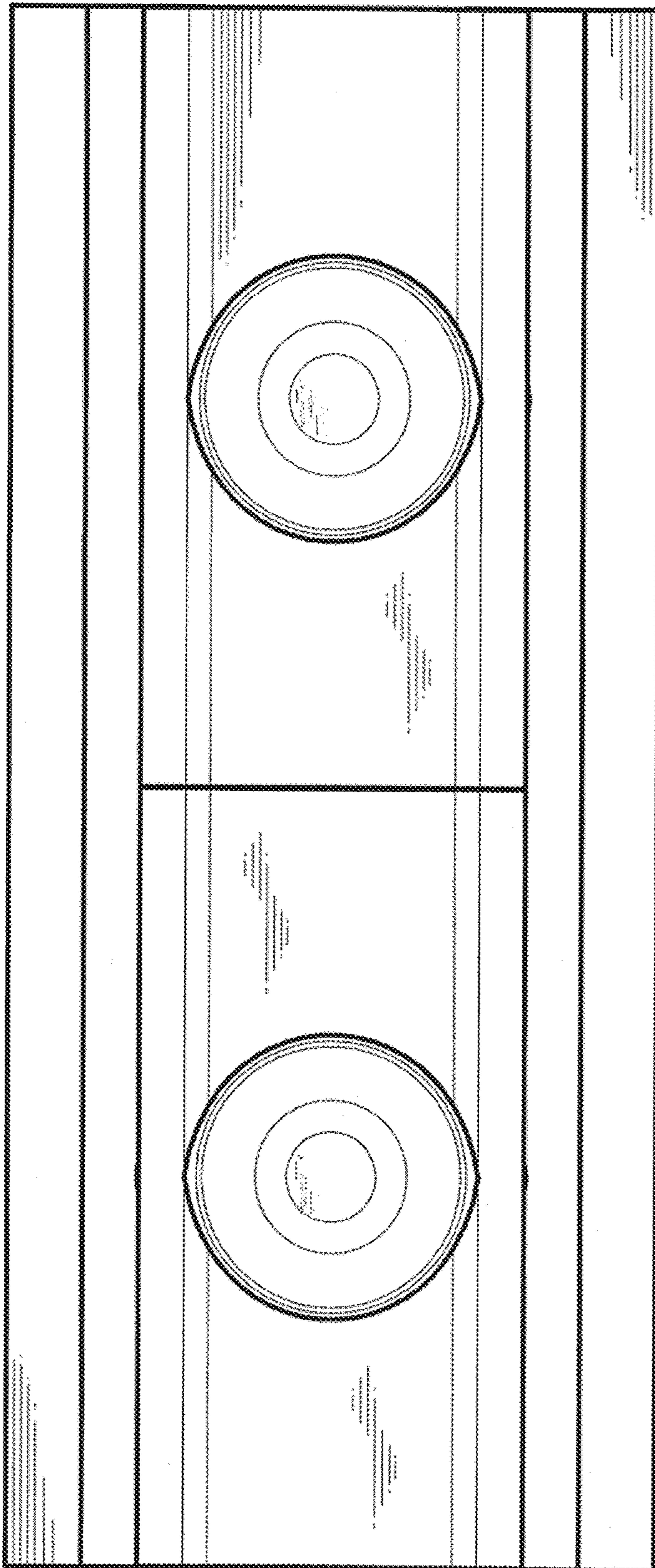

FIG. 4

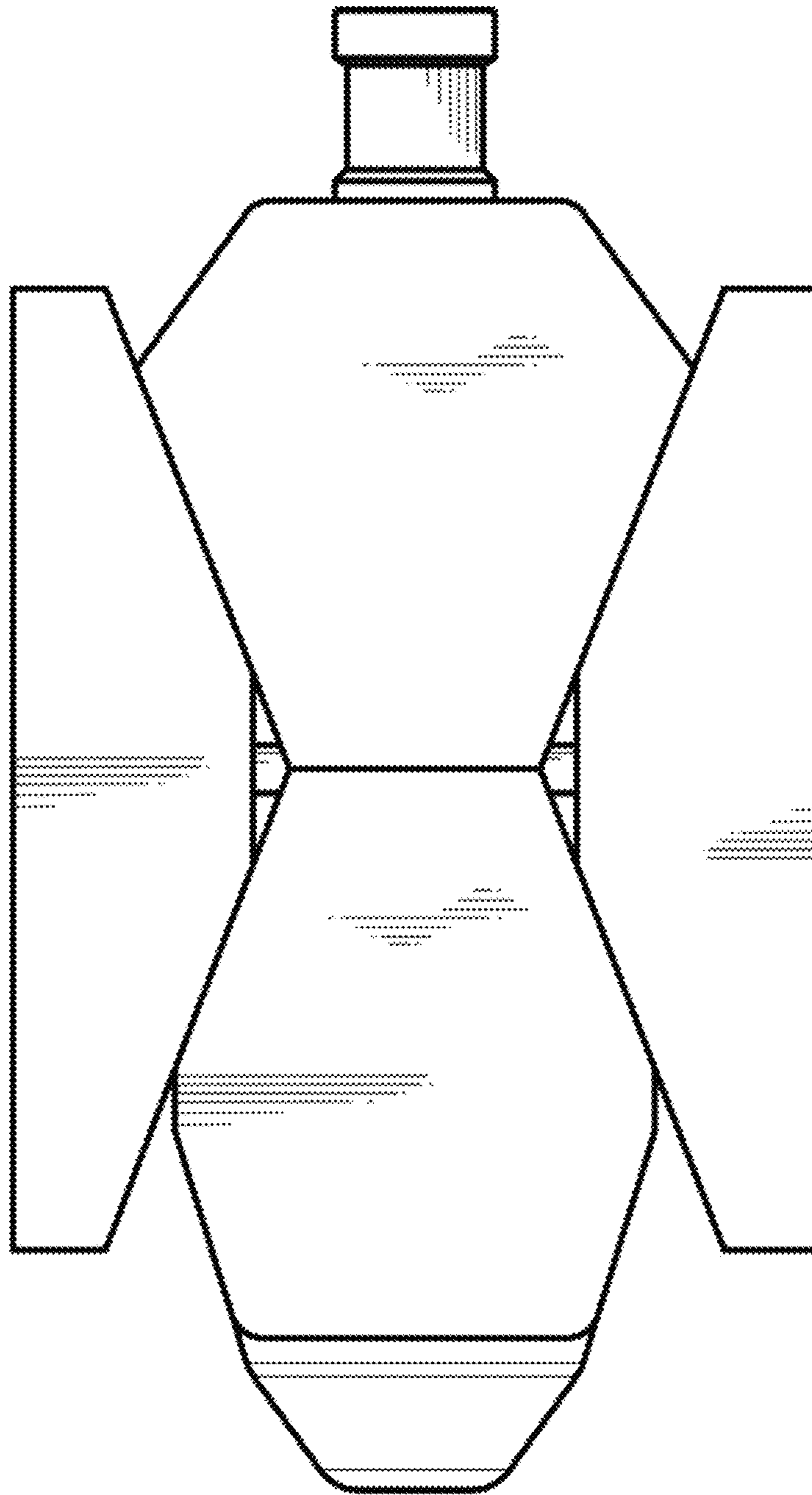
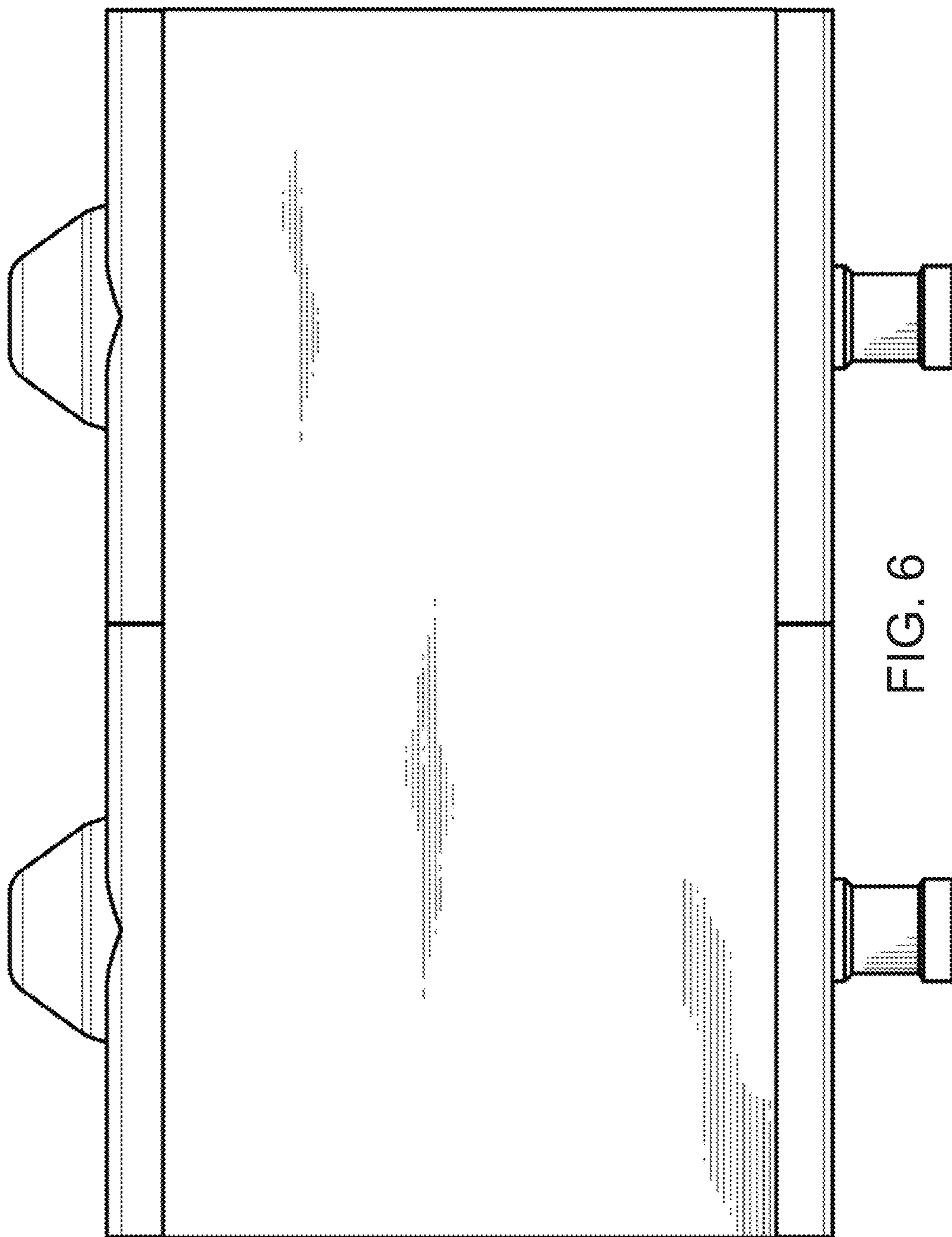

FIG. 5



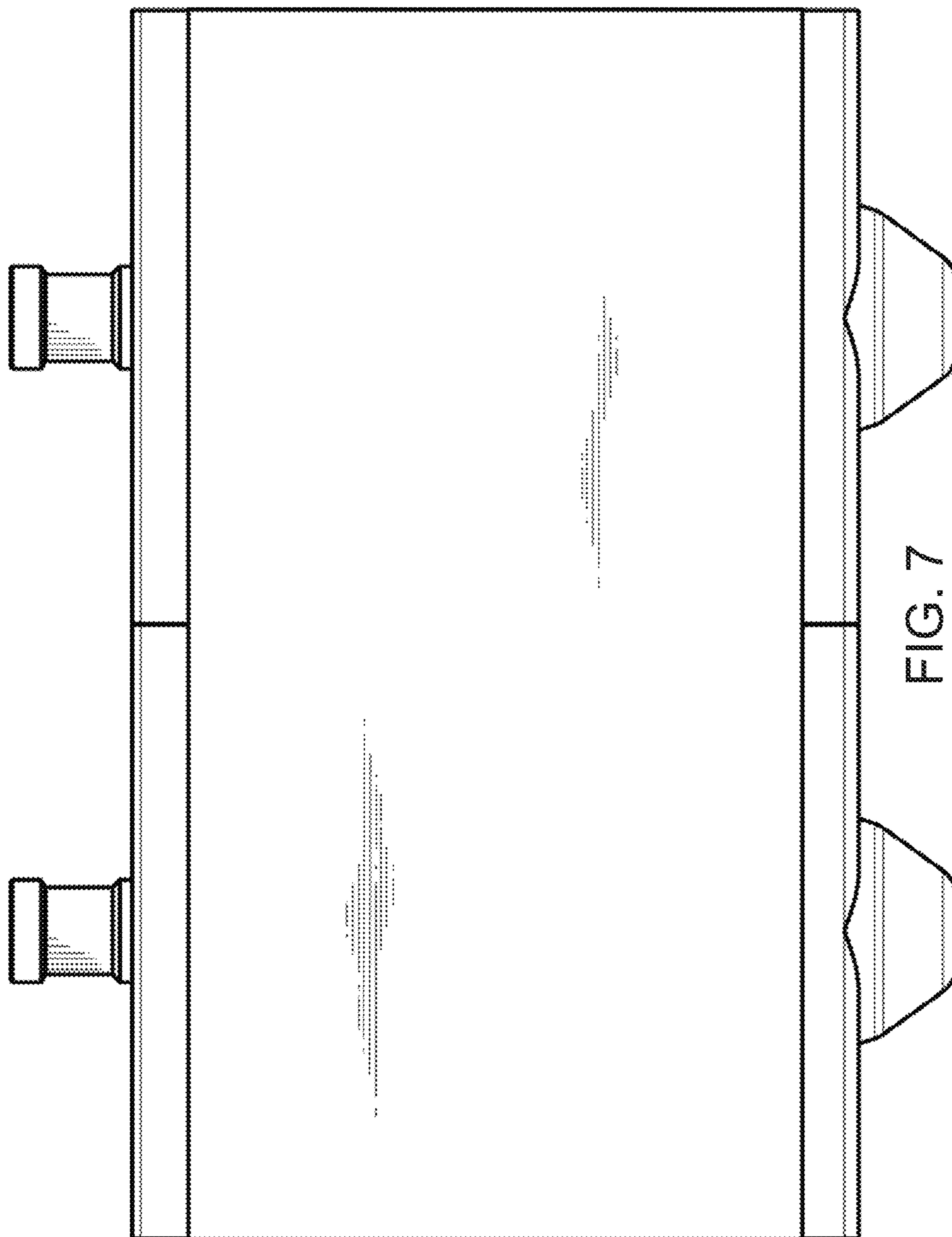

FIG. 7