



US00D750223S

(12) **United States Design Patent**  
**Andino et al.**

(10) **Patent No.:** **US D750,223 S**  
(45) **Date of Patent:** **\*\* Feb. 23, 2016**

(54) **MEDICAL INJECTOR FOR OCULAR INJECTION**

FOREIGN PATENT DOCUMENTS

(71) Applicant: **Clearside Biomedical, Inc.**, Alpharetta, GA (US)

EP 2193821 6/2010  
EP 2307055 4/2011

(Continued)

(72) Inventors: **Rafael Victor Andino**, Atlanta, GA (US); **Christopher John Brooks**, Glen Cove, NY (US)

OTHER PUBLICATIONS

Office Action for Russian Application No. 2012147341, dated Feb. 26, 2015, 8 pages.

(Continued)

(73) Assignee: **Clearside Biomedical, Inc.**, Alpharetta, GA (US)

*Primary Examiner* — David Muller

(74) *Attorney, Agent, or Firm* — Cooley LLP

(\*\*) Term: **14 Years**

(57) **CLAIM**

The ornamental design for a medical injector for ocular injection, as shown and described.

(21) Appl. No.: **29/506,275**

**DESCRIPTION**

(22) Filed: **Oct. 14, 2014**

(51) **LOC (10) Cl.** ..... **24-02**

(52) **U.S. Cl.**  
USPC ..... **D24/112**

(58) **Field of Classification Search**  
USPC ..... D24/112-114, 108, 130, 127, 133, 186; 606/181, 185; 604/264, 523-528, 272, 604/164.01-164.11, 187, 93.01; 600/101, 600/139, 143; 128/200.24, 207.14, 207.15; D8/303  
CPC . A61M 25/065; A61M 5/42; A61M 25/0612; A61M 25/00; A61M 39/00; A61M 27/00; A61M 25/0043; A61M 25/0067; A61M 25/0097; A61F 2/958  
See application file for complete search history.

FIG. 1 is a front left perspective view of the medical injector; FIG. 2 is a rear right perspective view thereof; FIG. 3 is a front view thereof; FIG. 4 is a rear view thereof; FIG. 5 is a left side view thereof; FIG. 6 is a right side view thereof; FIG. 7 is a top end view thereof; FIG. 8 is a bottom end view thereof; FIG. 9 is a front left perspective view of the medical injector illustrated in FIG. 1 without the needle cover present; FIG. 10 is a rear right perspective view thereof; FIG. 11 is a front view thereof; FIG. 12 is a rear view thereof; FIG. 13 is a left side view thereof; FIG. 14 is a right side view thereof; FIG. 15 is a top end view thereof; and, FIG. 16 is a bottom end view thereof.

The broken lines immediately adjacent the shaded areas represent the bounds of the claimed design while all other broken lines are directed to environment and are for illustrative purposes only; the broken lines form no part of the claimed design.

(56) **References Cited**

U.S. PATENT DOCUMENTS

4,601,708 A 7/1986 Jordan  
4,689,040 A 8/1987 Thompson  
4,708,147 A 11/1987 Haaga  
4,755,169 A 7/1988 Sarnoff et al.

(Continued)

**1 Claim, 10 Drawing Sheets**

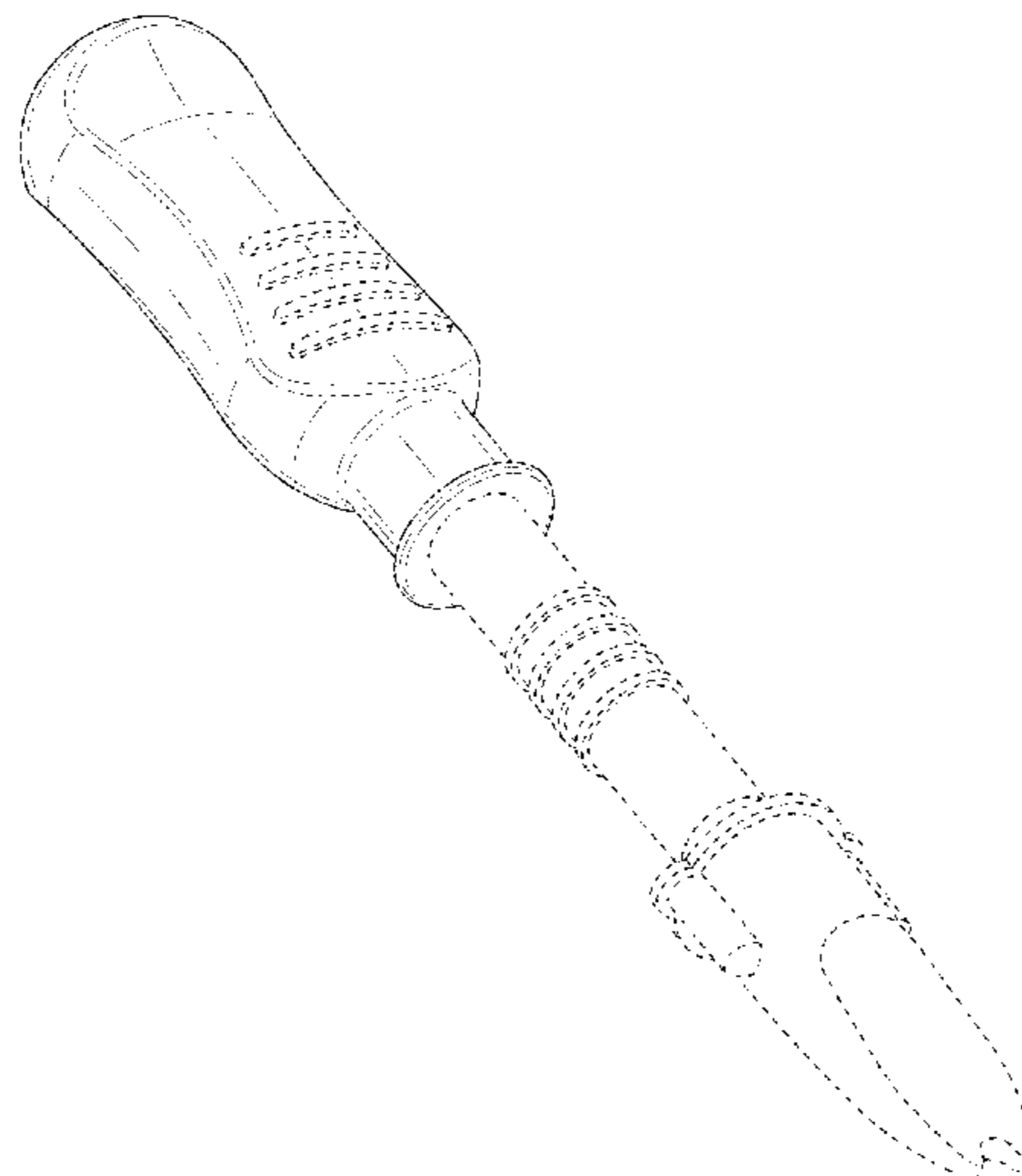

(56)

References Cited

U.S. PATENT DOCUMENTS

4,826,871 A	5/1989	Gressel et al.	8,574,214 B2	11/2013	Kuhn et al.
4,889,529 A	12/1989	Haindl	8,574,217 B2	11/2013	Peyman
4,966,773 A	10/1990	Gressel et al.	8,602,959 B1	12/2013	Park et al.
5,066,276 A	11/1991	Wang	8,617,121 B2	12/2013	Lanin et al.
5,098,389 A	3/1992	Cappucci	8,636,713 B2	1/2014	Prausnitz et al.
5,364,374 A	11/1994	Morrison et al.	8,652,118 B2	2/2014	Peyman
5,397,313 A	3/1995	Gross	8,663,167 B2	3/2014	Bartha
D383,049 S *	9/1997	Concari ..... D8/10	8,663,303 B2	3/2014	Horvath et al.
5,788,679 A	8/1998	Gravlee, Jr.	8,668,676 B2	3/2014	Chang
5,968,022 A	10/1999	Saito	8,702,659 B2	4/2014	Lanin et al.
6,083,199 A	7/2000	Thorley et al.	8,747,365 B2	6/2014	De Sausmarez Lintell
6,280,470 B1	8/2001	Peyman	8,795,226 B2	8/2014	Kuhn et al.
6,299,603 B1	10/2001	Hecker et al.	8,808,225 B2	8/2014	Prausnitz et al.
6,309,374 B1	10/2001	Hecker et al.	8,808,242 B2	8/2014	Paques et al.
6,319,240 B1	11/2001	Beck	D713,958 S *	9/2014	Srinivasan ..... D24/130
6,334,856 B1	1/2002	Allen et al.	8,821,870 B2	9/2014	Robinson et al.
6,378,526 B1	4/2002	Bowman et al.	D715,125 S *	10/2014	Hung ..... D8/107
6,387,078 B1	5/2002	Gillespie, III	8,852,137 B2	10/2014	Horvath et al.
6,397,849 B1	6/2002	Bowman et al.	8,864,740 B2	10/2014	Schabbach et al.
6,432,090 B1	8/2002	Brunel	D718,602 S *	12/2014	Musser ..... D8/107
6,503,231 B1	1/2003	Prausnitz et al.	D719,256 S *	12/2014	Ohashi ..... D24/108
6,524,581 B1	2/2003	Adamis	8,920,375 B2	12/2014	Gonnelli
6,540,725 B1	4/2003	Ponzi	D726,908 S *	4/2015	Yu ..... D24/130
6,551,299 B2	4/2003	Miyoshi et al.	D733,289 S *	6/2015	Blanchard ..... D24/112
6,611,707 B1	8/2003	Prausnitz et al.	D740,098 S *	10/2015	Kuo ..... D8/303
6,743,211 B1	6/2004	Prausnitz et al.	2001/0051798 A1	12/2001	Hochman
6,773,916 B1	8/2004	Thiel et al.	2002/0082543 A1	6/2002	Park et al.
D499,153 S *	11/2004	Kuo ..... D21/672	2003/0083645 A1	5/2003	Angel et al.
6,883,222 B2	4/2005	Landau	2004/0106904 A1	6/2004	Gonnelli et al.
6,918,889 B1	7/2005	Brunel	2004/0199130 A1	10/2004	Chornenky et al.
7,025,774 B2	4/2006	Freeman et al.	2004/0265365 A1	12/2004	Daddona et al.
7,150,735 B2	12/2006	Hickle	2005/0065137 A1	3/2005	Jani et al.
7,207,965 B2	4/2007	Simon	2005/0137525 A1	6/2005	Wang et al.
7,207,980 B2	4/2007	Christian et al.	2005/0209565 A1	9/2005	Yuzhakov et al.
7,211,062 B2	5/2007	Kwon	2006/0013859 A1	1/2006	Yamada et al.
7,214,212 B2	5/2007	Pommereau et al.	2006/0036318 A1	2/2006	Foulkes
7,226,439 B2	6/2007	Prausnitz et al.	2006/0084942 A1	4/2006	Kim et al.
7,316,676 B2	1/2008	Peyman et al.	2006/0086689 A1	4/2006	Raju
7,425,207 B2	9/2008	Miller et al.	2006/0173418 A1	8/2006	Rinaudo et al.
7,468,057 B2	12/2008	Ponzi	2006/0178614 A1	8/2006	Nemati
D590,690 S *	4/2009	Bertini ..... D8/303	2006/0189608 A1	8/2006	Bingaman
D598,543 S *	8/2009	Vogel ..... D24/133	2006/0229562 A1	10/2006	Marsh et al.
7,569,035 B1	8/2009	Wilmot et al.	2006/0233858 A1	10/2006	Tzekov et al.
7,615,041 B2	11/2009	Sullivan et al.	2006/0259008 A1	11/2006	Orilla
7,678,077 B2	3/2010	Harris et al.	2006/0271025 A1	11/2006	Jones et al.
7,678,078 B1	3/2010	Peyman et al.	2007/0060927 A1	3/2007	Longson et al.
7,722,581 B2	5/2010	Peyman	2007/0073197 A1	3/2007	Prausnitz et al.
7,914,803 B2	3/2011	Chowhan et al.	2007/0082841 A1	4/2007	Higuchi et al.
7,918,814 B2	4/2011	Prausnitz et al.	2007/0093877 A1	4/2007	Beecham et al.
7,918,874 B2	4/2011	Siegal	2007/0202186 A1	8/2007	Yamamoto et al.
7,947,660 B2	5/2011	Clark et al.	2007/0260201 A1	11/2007	Prausnitz et al.
7,967,772 B2	6/2011	McKenzie et al.	2008/0058704 A1	3/2008	Hee et al.
8,114,110 B2	2/2012	Bednarek et al.	2008/0131484 A1	6/2008	Robinson et al.
8,172,830 B2	5/2012	Christian et al.	2008/0228127 A1	9/2008	Burns et al.
8,173,617 B2	5/2012	Clark et al.	2009/0081277 A1	3/2009	Robinson et al.
8,192,408 B2	6/2012	Nazzaro et al.	2009/0105749 A1	4/2009	De Juan et al.
8,197,435 B2	6/2012	Prausnitz et al.	2009/0259180 A1	10/2009	Choi
8,221,353 B2	7/2012	Cormier et al.	2009/0287161 A1	11/2009	Traub et al.
8,235,967 B2	8/2012	Chevallier et al.	2009/0312782 A1	12/2009	Park
D667,111 S *	9/2012	Robinson ..... D24/133	2010/0010452 A1	1/2010	Paques et al.
8,287,494 B2	10/2012	Ma	2010/0015158 A1	1/2010	Robinson et al.
D672,506 S *	12/2012	Szymanski ..... D24/133	2010/0074957 A1	3/2010	Robinson et al.
8,323,227 B2	12/2012	Hamatake et al.	2010/0152646 A1	6/2010	Girijavallabhan et al.
8,328,772 B2	12/2012	Kinast et al.	2010/0152667 A1	6/2010	Kietzmann
8,337,421 B2	12/2012	Freeman et al.	2010/0173866 A1	7/2010	Hee et al.
8,337,509 B2	12/2012	Schieber et al.	2010/0312120 A1	12/2010	Meier
8,348,924 B2	1/2013	Christian et al.	2011/0060310 A1	3/2011	Prestrelski et al.
8,430,862 B2	4/2013	Peyman et al.	2011/0112546 A1	5/2011	Juan, Jr. et al.
8,460,242 B2	6/2013	Paques et al.	2011/0213317 A1	9/2011	Chen et al.
8,506,515 B2	8/2013	Burns et al.	2011/0238075 A1	9/2011	Clauson et al.
8,529,492 B2	9/2013	Clauson et al.	2011/0282298 A1	11/2011	Again et al.
8,535,333 B2	9/2013	de Juan, Jr. et al.	2012/0004245 A1	1/2012	May et al.
8,545,430 B2	10/2013	Silvestrini	2012/0029360 A1	2/2012	Hendriks et al.
8,545,554 B2	10/2013	Novakovic et al.	2012/0035524 A1	2/2012	Silvestrini
8,562,545 B2	10/2013	Freeman et al.	2012/0078224 A1	3/2012	Lerner et al.
			2012/0095414 A1	4/2012	Lanin et al.
			2012/0095438 A1	4/2012	Lanin et al.
			2012/0101475 A1	4/2012	Wilmot et al.
			2012/0116306 A1	5/2012	Heald et al.

(56)

## References Cited

## U.S. PATENT DOCUMENTS

2012/0123351 A1 5/2012 Lanin et al.  
 2012/0123437 A1 5/2012 Horvath et al.  
 2012/0123440 A1 5/2012 Horvath et al.  
 2012/0123473 A1 5/2012 Hernandez  
 2012/0136318 A1 5/2012 Lanin et al.  
 2012/0157880 A1 6/2012 Haselby et al.  
 2012/0165723 A1 6/2012 Horvath et al.  
 2012/0191064 A1 7/2012 Conston et al.  
 2012/0197208 A1 8/2012 Bruggemann et al.  
 2012/0259288 A1 10/2012 Wagner et al.  
 2012/0271272 A1 10/2012 Hammack et al.  
 2013/0035662 A1 2/2013 Decker et al.  
 2013/0060202 A1 3/2013 Thorley et al.  
 2013/0072900 A1 3/2013 Colantonio  
 2013/0079716 A1 3/2013 Thorley et al.  
 2013/0096533 A1 4/2013 Freeman et al.  
 2013/0102973 A1 4/2013 Thorley et al.  
 2013/0116523 A1 5/2013 Jung et al.  
 2013/0138049 A1 5/2013 Kemp et al.  
 2013/0140208 A1 6/2013 Hemmann  
 2013/0150803 A1 6/2013 Shetty et al.  
 2013/0190694 A1 7/2013 Barrow-Williams et al.  
 2013/0218102 A1 8/2013 Iwase et al.  
 2013/0237910 A1 9/2013 Shetty et al.  
 2013/0237916 A1 9/2013 Hanson et al.  
 2013/0245600 A1 9/2013 Yamamoto et al.  
 2013/0331786 A1 12/2013 Hofmann  
 2013/0338612 A1 12/2013 Smith et al.  
 2014/0012226 A1 1/2014 Hochman  
 2014/0031833 A1 1/2014 Novakovic et al.  
 2014/0039391 A1 2/2014 Clarke et al.  
 2014/0039413 A1 2/2014 Jugl et al.  
 2014/0094752 A1 4/2014 Hiles  
 2014/0114243 A1 4/2014 Smith et al.  
 2014/0135716 A1 5/2014 Clarke et al.  
 2014/0200518 A1 7/2014 Ekman et al.  
 2014/0224688 A1 8/2014 Slemmen et al.  
 2014/0236098 A1 8/2014 Mica et al.  
 2014/0243754 A1 8/2014 Clarke et al.  
 2014/0249539 A1 9/2014 Mica et al.  
 2014/0257207 A1 9/2014 Clarke et al.  
 2014/0296802 A1 10/2014 Geiger et al.  
 2014/0323979 A1 10/2014 Henley et al.  
 2014/0323985 A1 10/2014 Hourmand et al.  
 2014/0330213 A1 11/2014 Hourmand et al.  
 2014/0350479 A1 11/2014 Hourmand et al.  
 2015/0013827 A1 1/2015 Kuhn  
 2015/0013835 A1 1/2015 Cordes  
 2015/0025474 A1 1/2015 Riedel et al.  
 2015/0038905 A1 2/2015 Andino et al.  
 2015/0045731 A1 2/2015 Gupta et al.  
 2015/0045744 A1 2/2015 Gupta et al.  
 2015/0051545 A1 2/2015 Henderson et al.  
 2015/0051581 A1 2/2015 Andino et al.

## FOREIGN PATENT DOCUMENTS

RU 2428956 9/2011  
 WO WO 00/07565 2/2000  
 WO WO 00/07530 12/2000  
 WO WO 03/024507 3/2003  
 WO WO 2006/004595 1/2006  
 WO WO 2006/058189 6/2006  
 WO WO 2006/128034 11/2006  
 WO WO 2006/138719 12/2006  
 WO WO 2007/100745 9/2007  
 WO WO 2010/009034 1/2010  
 WO WO 2010/054660 5/2010  
 WO WO 2011/057065 5/2011  
 WO WO 2013/098166 7/2013

WO WO 2013/151904 10/2013  
 WO WO 2014/028285 2/2014  
 WO WO 2015/015467 2/2015

## OTHER PUBLICATIONS

Anthem, Medical Policy, Suprachoroidal Injection of a Pharmacologic Agent, Nov. 14, 2013, Retrieved from the Internet: <URL: [http://www.anthem.com/medicalpolicies/policies/mp\\_pw\\_b076412.htm](http://www.anthem.com/medicalpolicies/policies/mp_pw_b076412.htm)>, 3 pages.  
 Beer, P. J. et al., "Photographic Evidence of Vitreous Wicks After Intravitreal Injections," *Retina Today*, 2(2):24-39 (Mar. 2007).  
 Berglin, L. C. et al., "Tracing of Suprachoroidally Microneedle Injected Labeled Drugs and Microbeads in Human, Pig and Rabbit Tissue Using Liquid Nitrogen Snap-Freeze Thaw and Lypholization Techniques," *Invest Ophthalmol Vis Sci.*, 51:E-Abstract 5330 (2010), 2 pages.  
 Careforde Healthcare, B Braun Glass Loss-Of-Resistance Syringes # 332155-5cc Glass Loss-Of-Resistance Syringe, Luer Lock Metal Tip, 10/cs, [online], <<http://careforde.com/b-braun-glass-loss-of-resistance-syringes-332155-5cc-glass-loss-of-r...>> (2014), 2 pages.  
 Careforde Healthcare, B Braun Glass Loss-Of-Resistance Syringes # 332158-10cc Glass Loss-Of-Resistance Syringe, Luer Slip Metal Tip, 10/cs, [online], <<http://careforde.com/b-braun-glass-loss-of-resistance-syringes-332158-10cc-glass-loss-of...>> (2014), 2 pages.  
 Careforde Healthcare, B Braun Perifix Plastic Loss-Of-Resistance Syringes # 332152-8cc Plastic Luer Lock Loss-of-Resistance Syringe, 50/cs, [online], <<http://careforde.com/b-braun-perifix-plastic-loss-of-resistance-syringes-332152-8cc-plasti...>> (2014), 2 pages.  
 Choy, Y. B. et al., "Mucoadhesive microdiscs engineered for ophthalmic drug delivery: effect of particle geometry and fomulation on preocular residence time," *Investigative Ophthalmology & Visual Science*, 49:4808-4815 (2008).  
 Edwards, A. et al., "Fiber matrix model of sclera and corneal stroma for drug delivery to the eye," *AICHE Journal*, 44(1):214-225 (1998).  
 Einmahl, S. et al., "Evaluation of a novel biomaterial in the suprachoroidal space of the rabbit eye," *Invest. Ophthalmol. Vis. Sci.*, 43(5):1533-1539 (2002).  
 "Epidural," Wikipedia [online], retrieved from the internet on Sep. 3, 2014, <URL: <http://en.wikipedia.org/wiki/Epidural>>, 21 pages.  
 Feldkamp, L. A. et al., "Practical cone-beam algorithm," *J. Opt. Soc. Am. A*, 1(6):612-619 (1984).  
 Geroski, D. H. et al., "Drug delivery for posterior segment eye disease," *Invest. Ophthalmol. Vis. Sci.*, 41(5):961-964 (2000).  
 Hanekamp, S. et al., "Inhibition of Corneal and Retinal Angiogenesis by Organic Integrin Antagonists After Intrasceral or Intravitreal Drug Delivery," *Invest Ophthalmol Vis. Sci.*, 43: E-Abstract 3710, ARVO (2002), 2 pages.  
 Hoagan et al., Chapter Eight, Choroid, in *Histology of the Human Eye*, pp. 322-392 (1971).  
 Jain, A., "Pseudo loss of resistance in epidural space localization: A complication of subcutaneous emphysema or simply a faulty technique," *Saudi J. Anesth*, 5(1):108-109 (2011) (Abstract).  
 Jiang, J. et al., "Measurement and Prediction of Lateral Diffusion within Human Sclera," *Investigative Ophthalmology & Visual Science*, 47(7):3011-3016 (2006).  
 Jiang, J. et al., "Coated Microneedles for Drug Delivery to the Eye," *Investigative Ophthalmology & Visual Science*, 48(9):4038-4043 (2007).  
 Jiang, J. et al., "Intrasceral drug delivery to the eye using hollow microneedles," *Pharmaceutical Research*, 26(2):395-403 (2009).  
 Lee, S-B et al., "Drug delivery through the sclera: effects of thickness, hydration and sustained release systems," *Experimental Eye Research*, 78:599-607 (2004).  
 Lindfield, D. et al., "Suprachoroidal Devices in Glaucoma. The Past, Present, and Future of Surgery for Suprachoroidal Drainage," *Cataract & Refractive Surgery Today* [online], Oct. 2013, Retrieved from the Internet: <URL: <http://bmctoday.net/crstodayeurope/2013/10/article.asp?f=suprachoroidal-devices-in-glau...>>, 3 pages.  
 Loewen, N., "The suprachoroidal space in glaucoma surgery," *Jul. 2012*, 4 pages.

(56)

**References Cited**

## OTHER PUBLICATIONS

Maurice, D., "Review: Practical Issues in Intravitreal Drug Delivery," *J. Ocul. Pharmacol. Ther.*, 17(4):393-401 (2001).

McAllister, D. V. et al., "Microfabricated needles for transdermal delivery of macromolecules and nanoparticles: Fabrication methods and transport studies," *Proc. Nat'l Acad. Sci USA*, 100(24):13755-13760 (2003).

Norman, D., Epidural analgesia using loss of resistance with air versus saline. Does it make a difference? Should we reevaluate our practice?, *AANA Journal*, 71(6):449-453 (Dec. 2003).

Olsen, T. W. et al., "Cannulation of the Suprachoroidal Space: A Novel Drug Delivery Methodology to the Posterior Segment," *American J. Ophthalmology*, 142(5):777-787 (2006).

Olsen, T., "Drug Delivery to the Suprachoroidal Space Shows Promise," *Retina Today*, pp. 36-39 (Mar./Apr. 2007).

Patel, S. et al., "Suprachoroidal Drug Delivery Using Microneedles," *Invest. Ophthalmol. Vis. Sci.*, 49:E-Abstract 5006 (2008), 2 pages.

Patel, S. et al., "Drug Binding to Sclera," *Invest Ophthalmol Vis Sci.*, 50:E-Abstract 5968 (2009), 2 pages.

Patel, S. R. et al., "Intraocular Pharmacokinetics of Suprachoroidal Drug Delivery Administered Using Hollow Microneedles," *Invest Ophthalmol Vis Sci.*, 51:E-Abstract 3796 (2010), 2 pages.

Penkov, M. A. et al., "A ten-year experience with usage of the method of supra-choroidal administration of medicinal substances," *Oftalmol. Zh.*, 35(5):281-285 1980.

Prausnitz, M. R. et al., "Permeability to cornea, sclera and conjunctiva: A literature analysis for drug delivery to the eye," *Journal of Pharmaceutical Sciences*, 87(12):1479-1488 (1998).

Prausnitz, M. R. et al., "Measurement and prediction of transient transport across sclera for drug delivery to the eye," *Industrial and Engineering Chemistry Research*, 37(8):2903-2907 (1998).

Prausnitz, M. R. et al., "Microneedles for Ocular Drug Delivery," of Olsen, T., *Drug Delivery to the Suprachoroidal Space Shows Promise*, *Retina Today*, Mar./Apr. 2007, p. 39.

Rowe-Rendleman, C. L. et al., "Prophylactic Intra-Scleral Injection of Steroid Compounds in Rabbit Model of Retinal Neovascularization," *Invest Ophthalmol Vis. Sci.*, 43:E-Abstract 3872, ARVO (2002), 2 pages.

Saberski, L. R. et al., "Identification of the epidural space: Is loss of resistance to air a safe technique? A review of the complications related to the use of air," *Regional Anesthesia*, 22(1):3-15 (1997).

Shuler, R. K. et al., "Scleral Permeability of a Small, Single-Stranded Oligonucleotide," *Journal of Ocular Pharmacology and Therapeutics*, 20(2):159-168 (2004) (Abstract).

Wang, P. M. et al., "Minimally Invasive Extraction of Dermal Interstitial Fluid for Glucose Monitoring Using Microneedles," *Diabetes Technology & Therapeutics*, 7(1):131-141 (2005).

\* cited by examiner

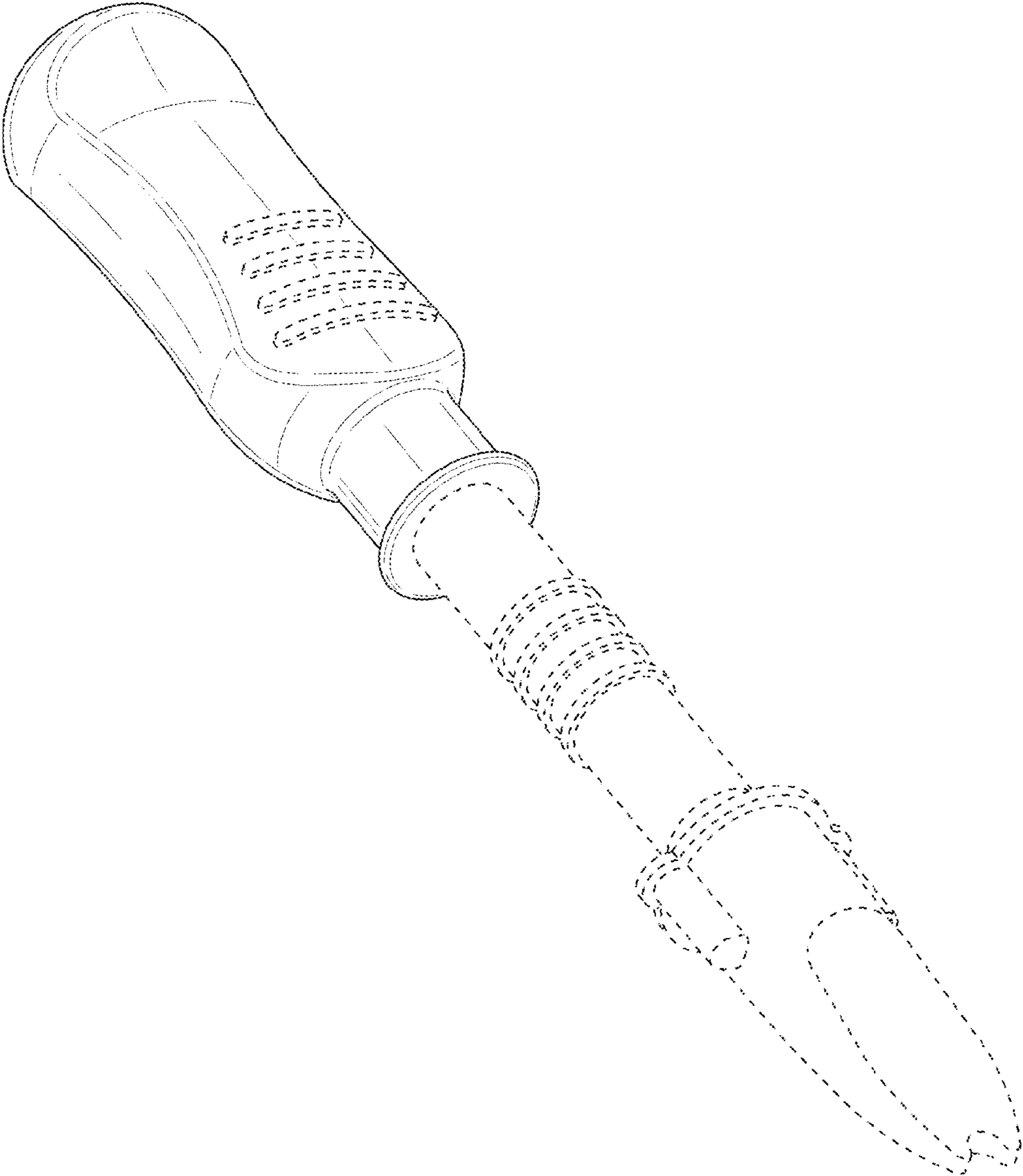

FIG. 1

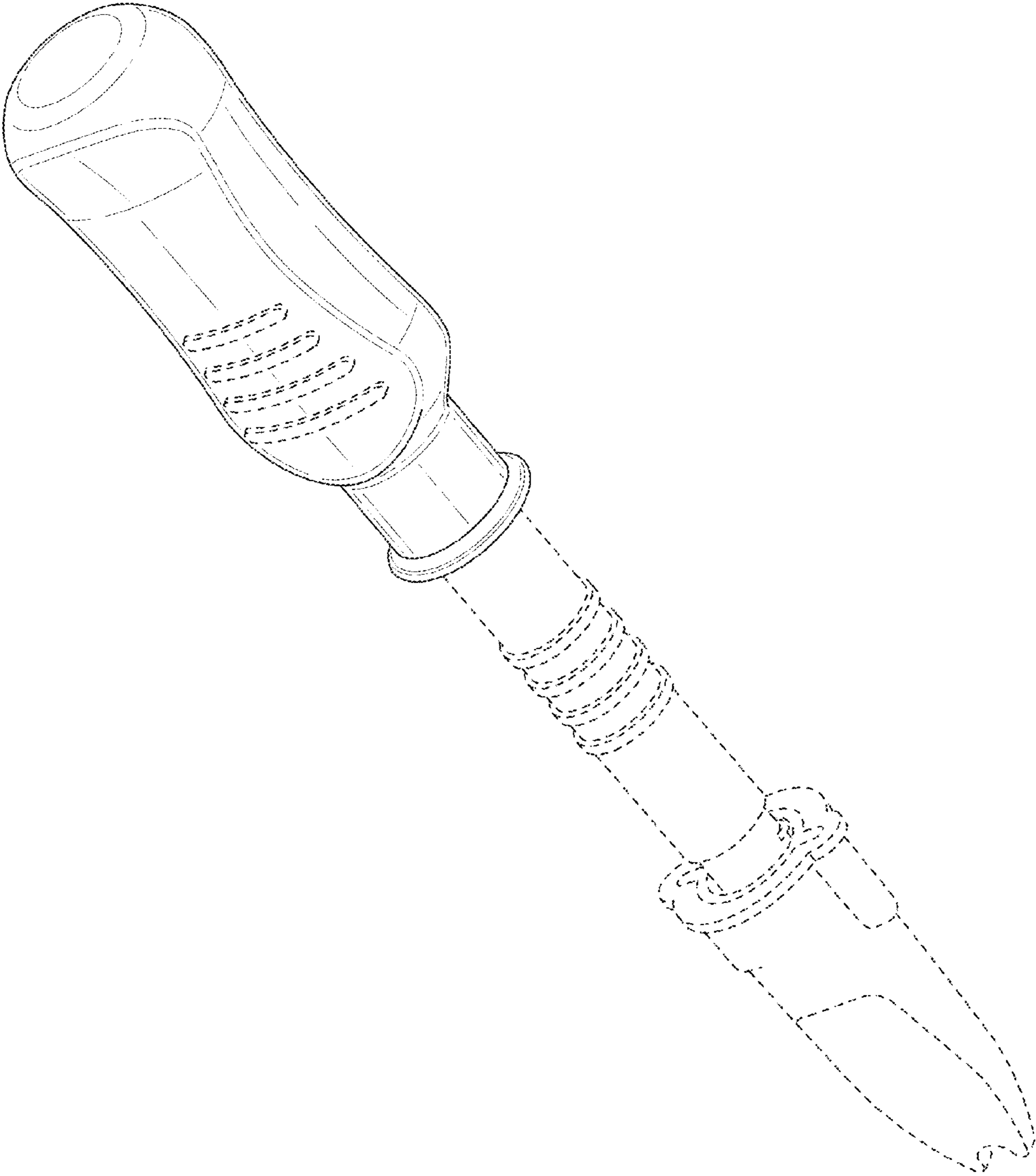

FIG.2

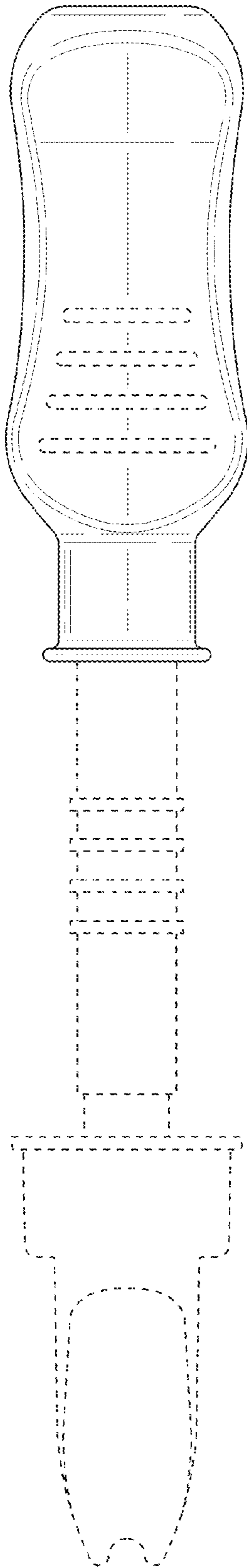

FIG. 3

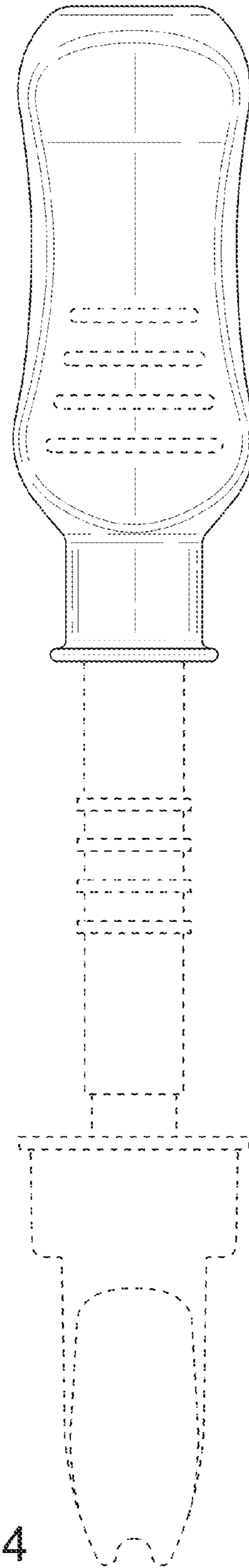

FIG. 4

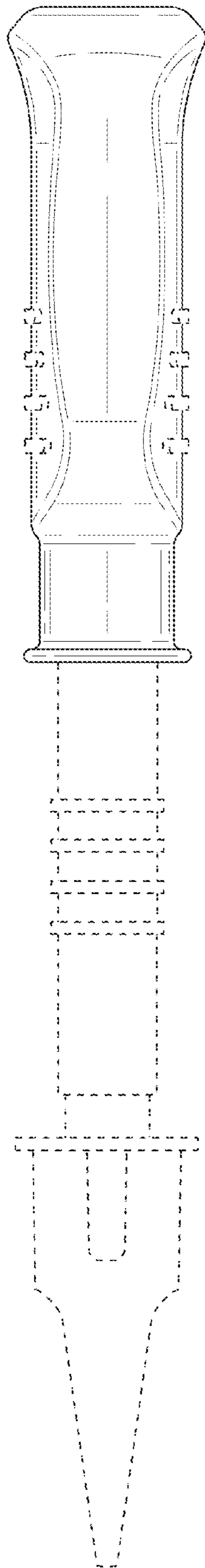

FIG. 5

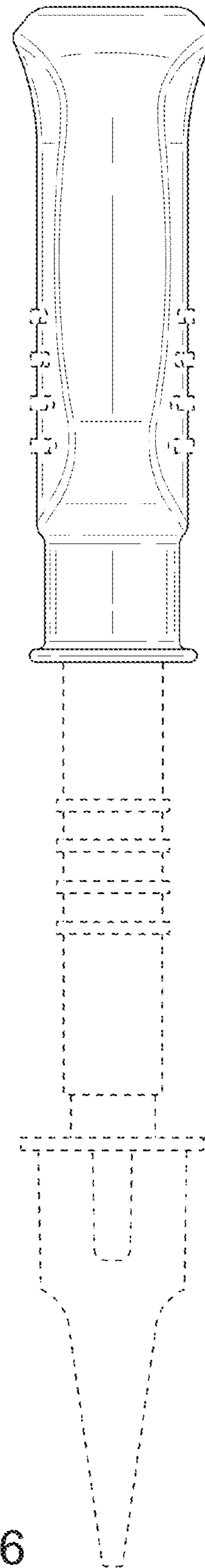

FIG. 6



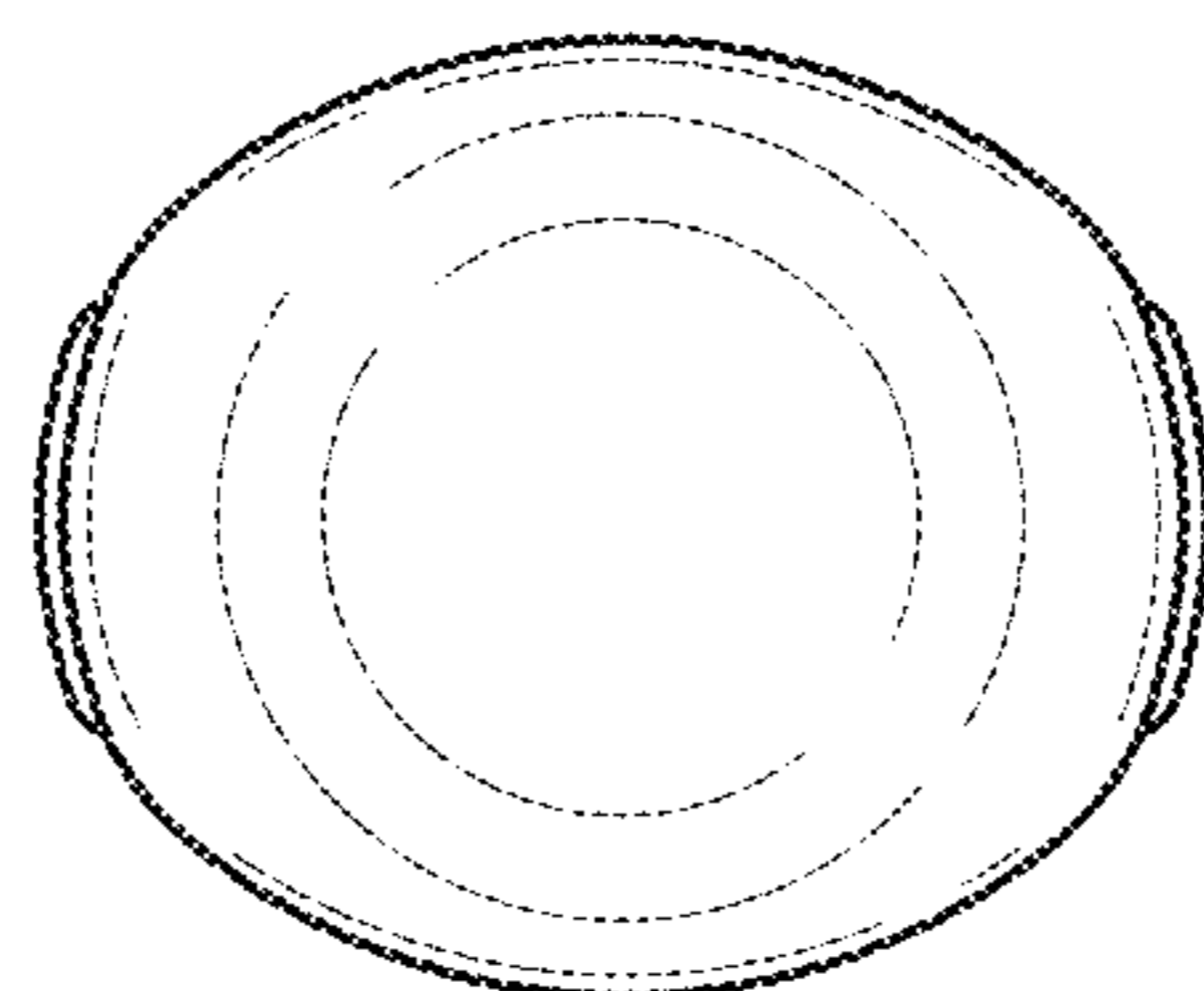

FIG. 7

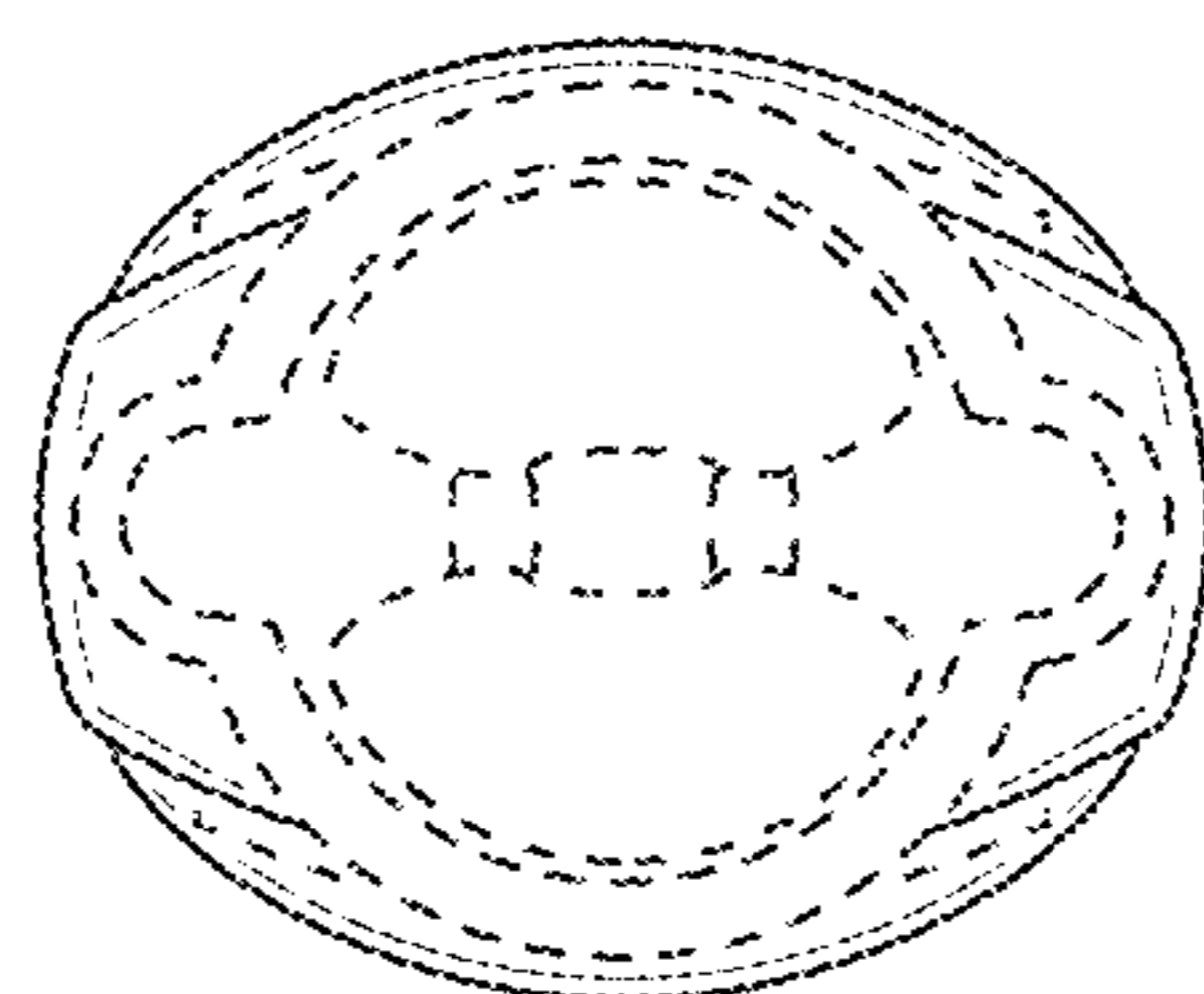

FIG. 8

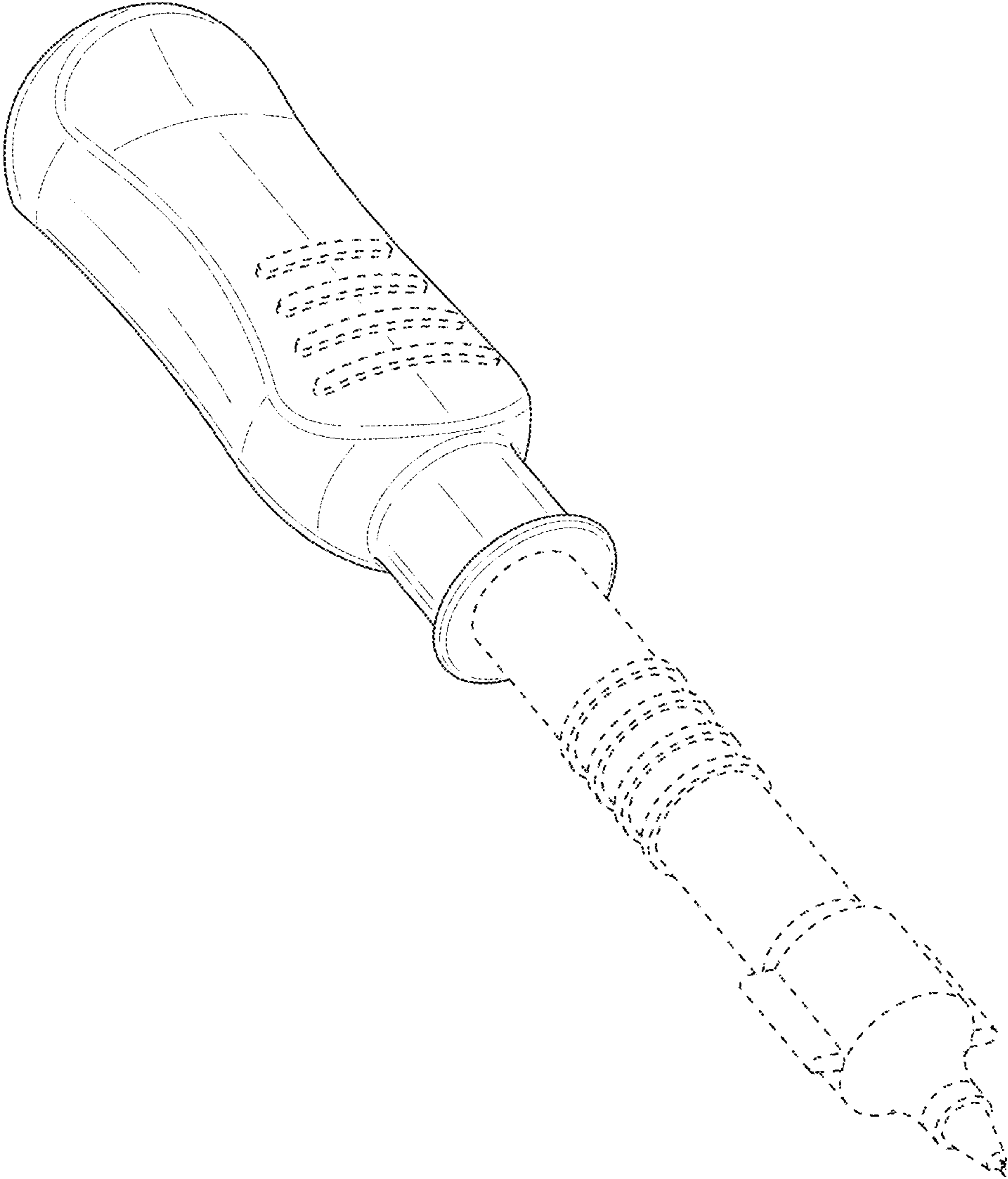

FIG.9

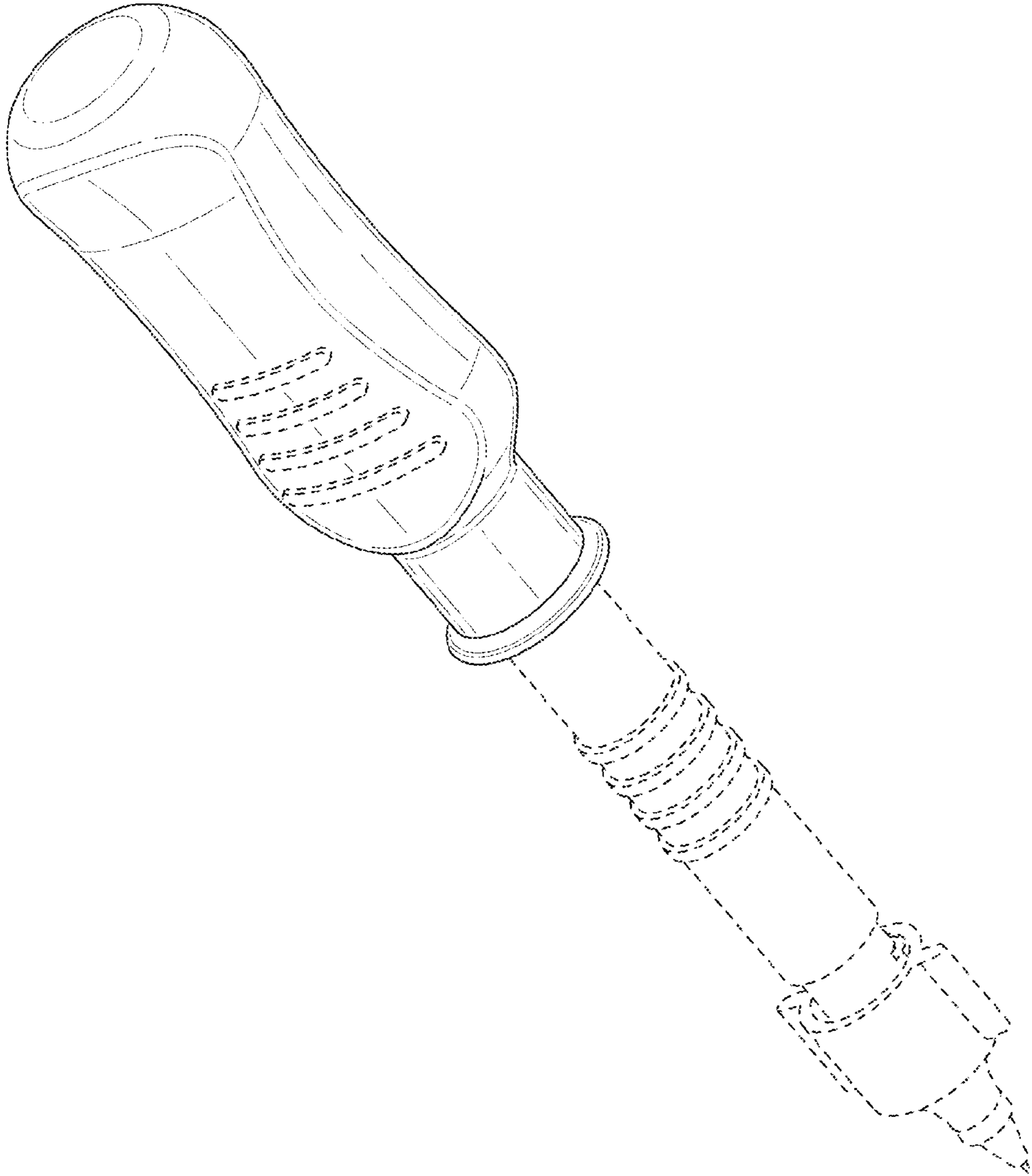

FIG. 10

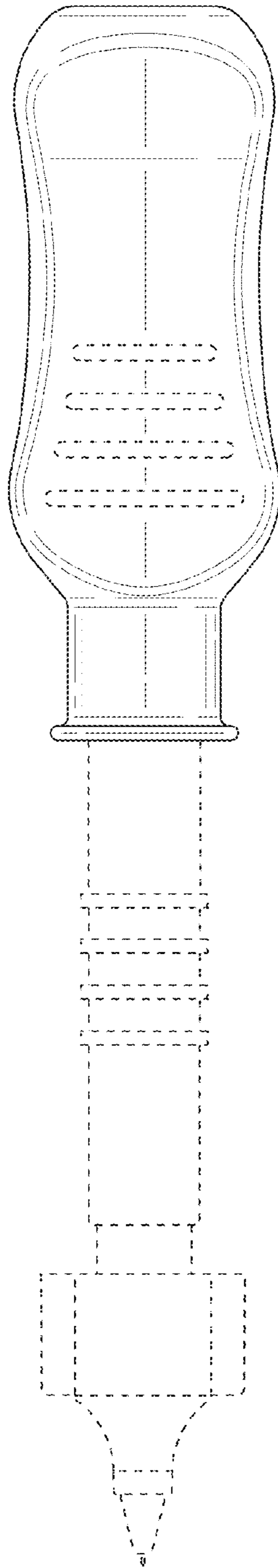

FIG. 11

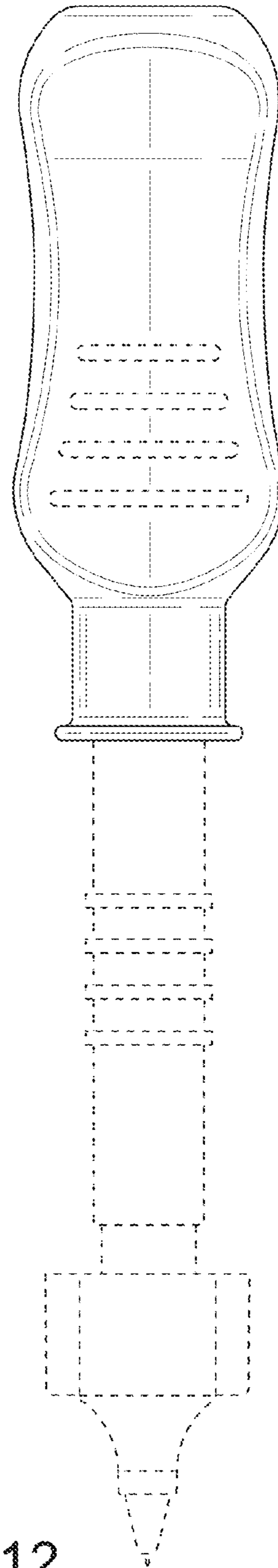

FIG. 12

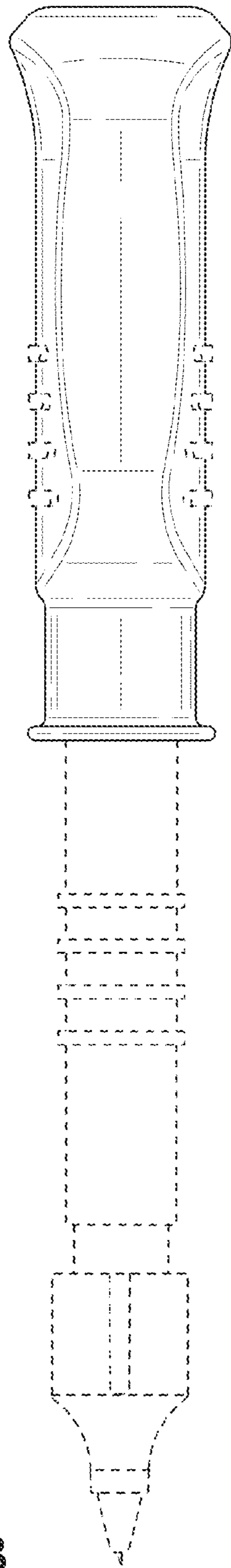

FIG. 13

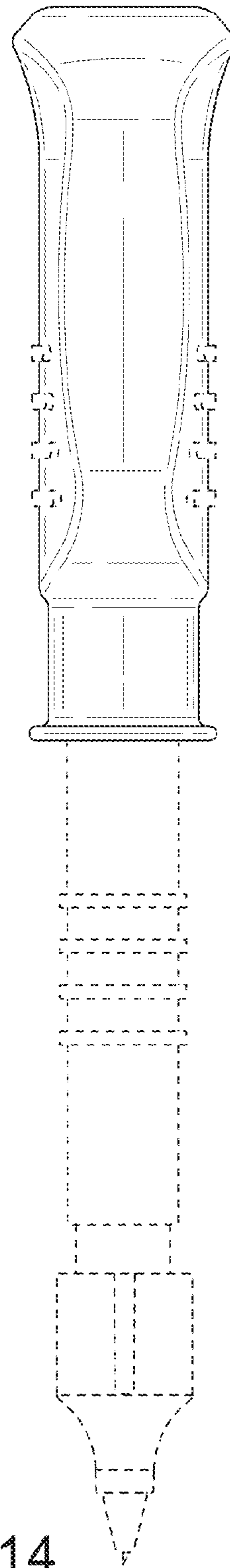

FIG. 14

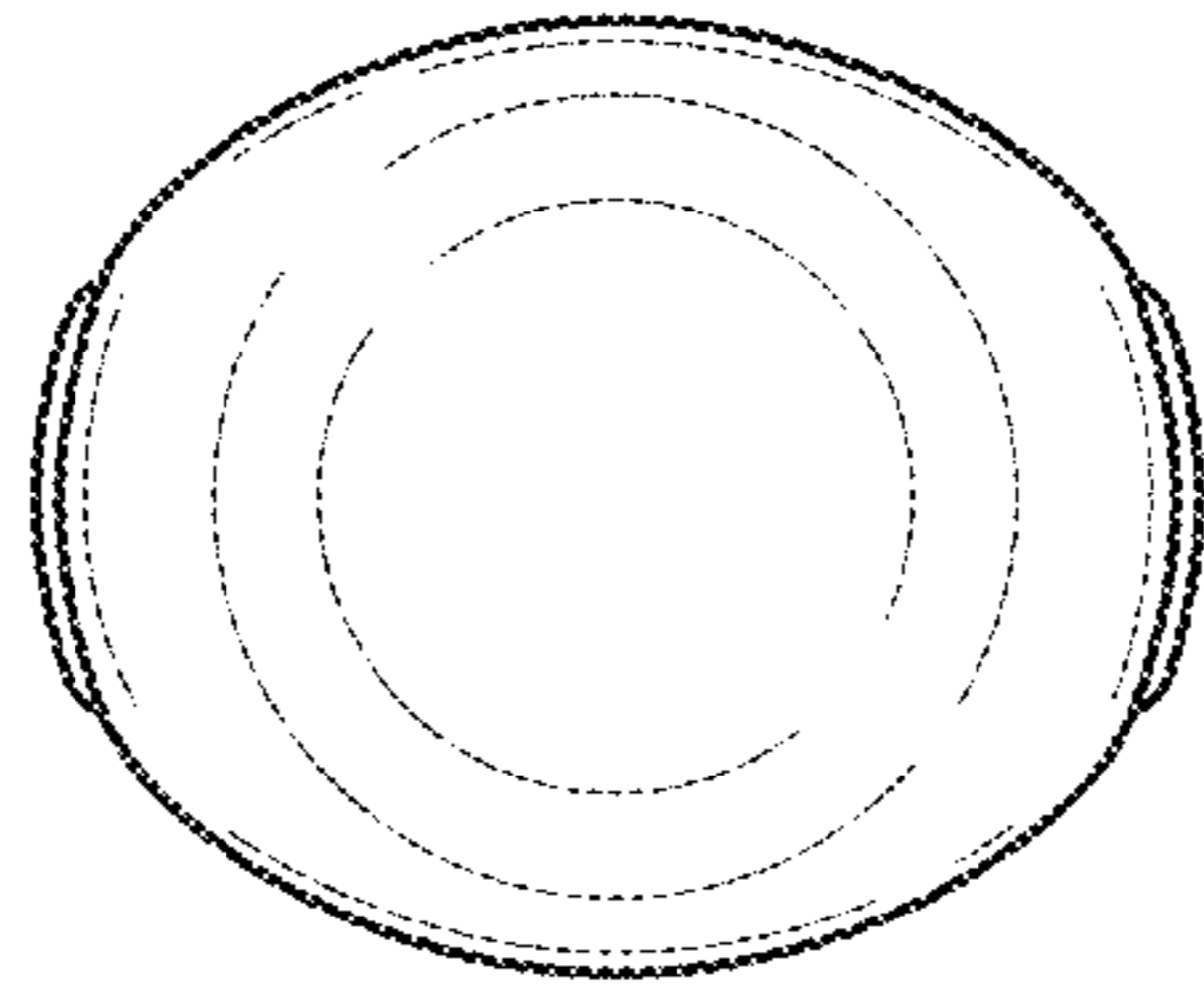

FIG. 15

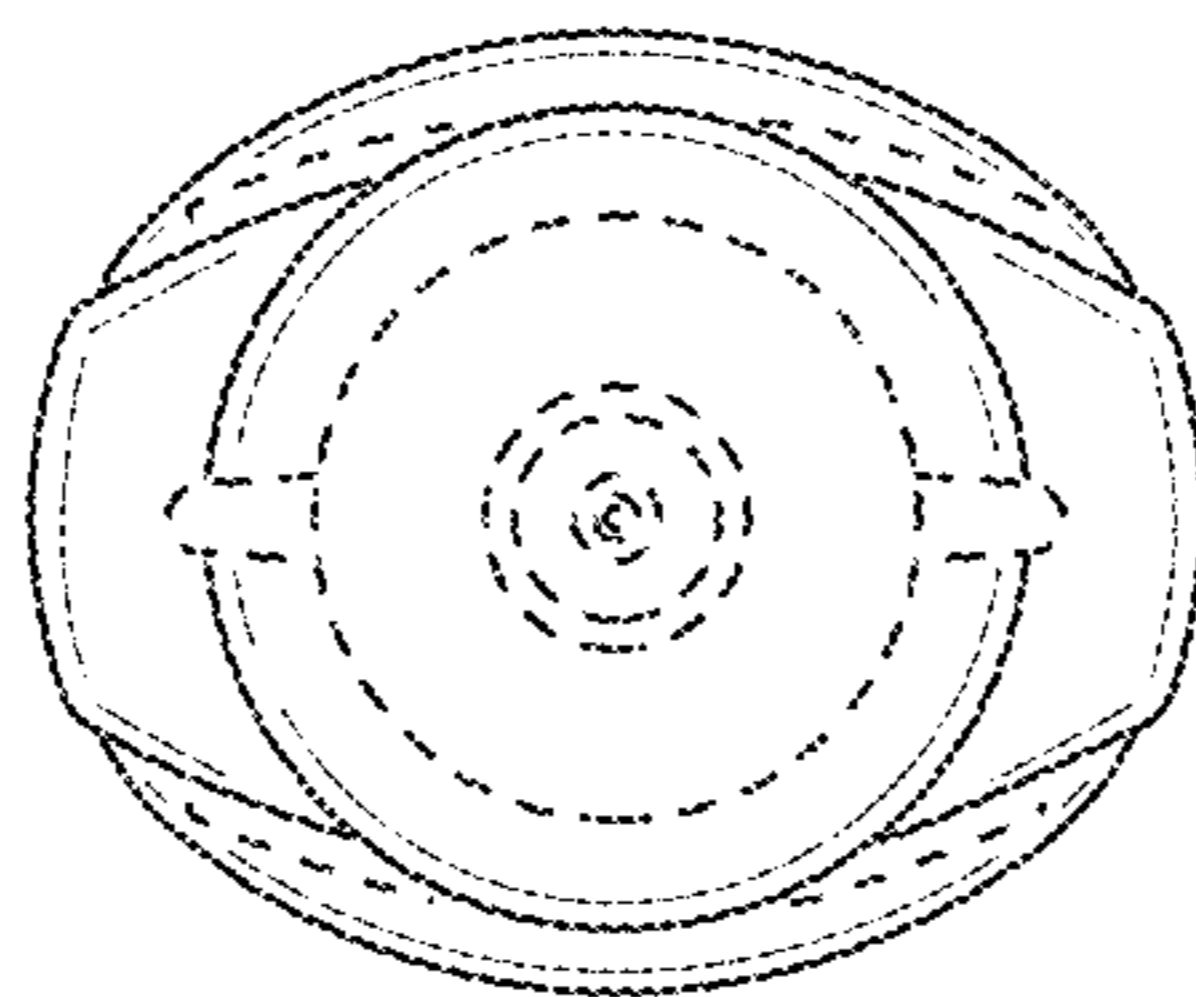

FIG. 16