



US00D750207S

(12) **United States Design Patent**  
**VanderBoegh**

(10) **Patent No.:** **US D750,207 S**

(45) **Date of Patent:** **\*\* Feb. 23, 2016**

- (54) **POOL FLOOR INLET EXTENDER**
- (71) Applicant: **Alan D VanderBoegh**, Altamonte Springs, FL (US)
- (72) Inventor: **Alan D VanderBoegh**, Altamonte Springs, FL (US)
- (\*\*) Term: **14 Years**
- (21) Appl. No.: **29/474,481**
- (22) Filed: **Oct. 6, 2014**
- (51) **LOC (10) Cl.** ..... **23-01**
- (52) **U.S. Cl.**  
USPC ..... **D23/259**
- (58) **Field of Classification Search**  
USPC ..... D23/259-263, 266-269, 233; 251/215, 251/216; 285/369, 372, 373, 417, 133.11, 285/133.3, 133.21, 133.4, 133.5, 133.6; 137/247, 247.41, 247.51  
CPC ..... F16L 11/00; F16L 37/252; F16L 41/007; E03C 1/26; E03C 1/262; E03C 1/28; E03F 5/04; A61B 5/00; A61M 25/09016  
See application file for complete search history.

- 4,146,939 A \* 4/1979 Izzi ..... E03F 5/0409 4/286
- D336,510 S \* 6/1993 Sawtelle ..... D23/262
- 5,372,715 A \* 12/1994 Maggard ..... E03F 5/0408 210/164
- 5,376,264 A \* 12/1994 Betancourt ..... B01D 29/01 210/166
- D449,873 S \* 10/2001 Bronson ..... D23/261
- D513,072 S \* 12/2005 Berg ..... D23/386
- D616,966 S \* 6/2010 Angell ..... D23/262
- D626,208 S \* 10/2010 Clements ..... D23/365
- D706,908 S \* 6/2014 Knapp ..... D23/269
- D730,734 S \* 6/2015 Rapparini ..... D9/454
- 9,089,805 B2 \* 7/2015 Lepine ..... B01D 46/2414
- 2009/0133188 A1 \* 5/2009 Peng ..... A61H 33/6063 4/541.6

\* cited by examiner

*Primary Examiner* — Sandra Snapp

- (56) **References Cited**  
U.S. PATENT DOCUMENTS  
1,798,246 A \* 3/1931 Braner ..... F16J 15/128 277/598  
3,040,895 A \* 6/1962 Sisk ..... E03F 5/0407 210/164

(57) **CLAIM**  
The ornamental design for a pool floor inlet extender, as shown and described.

**DESCRIPTION**

FIG. 1 is a top plan view of my new pool floor inlet extender; FIG. 2 is a bottom plan view thereof; FIG. 3 is a side elevational view thereof, it being understood that all side elevational views are identical thereto; and, FIG. 4 is a cross-sectional view taken along line 4-4 of FIG. 1.

**1 Claim, 1 Drawing Sheet**

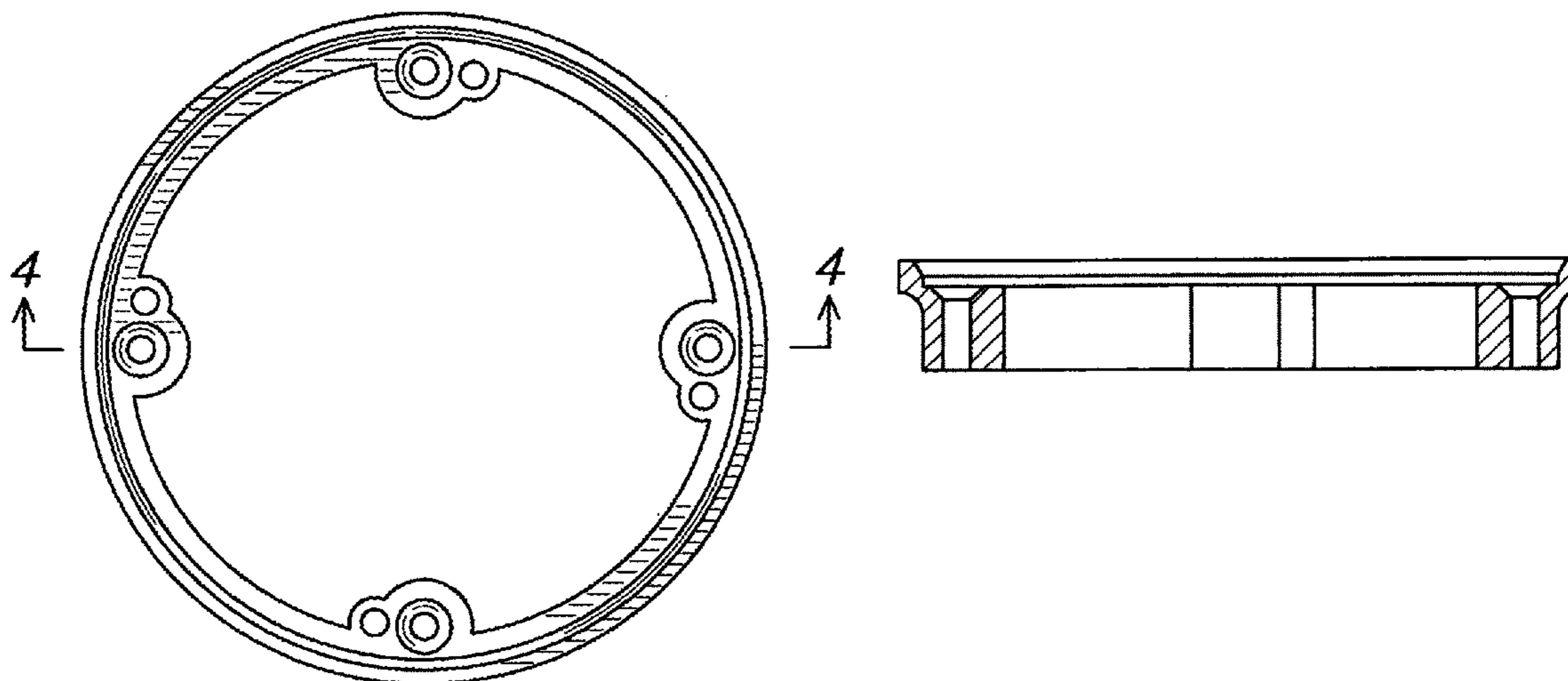

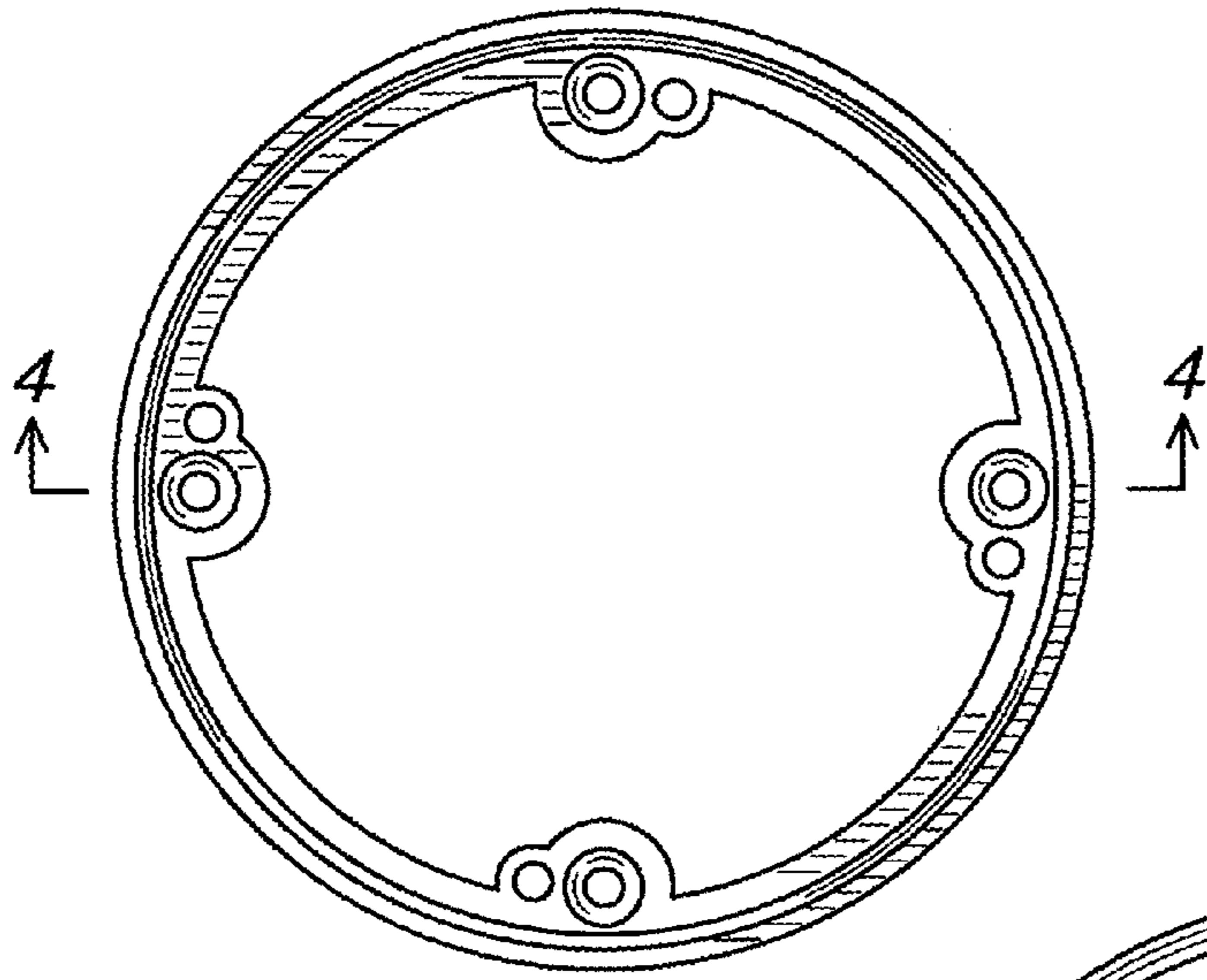

FIG. 1

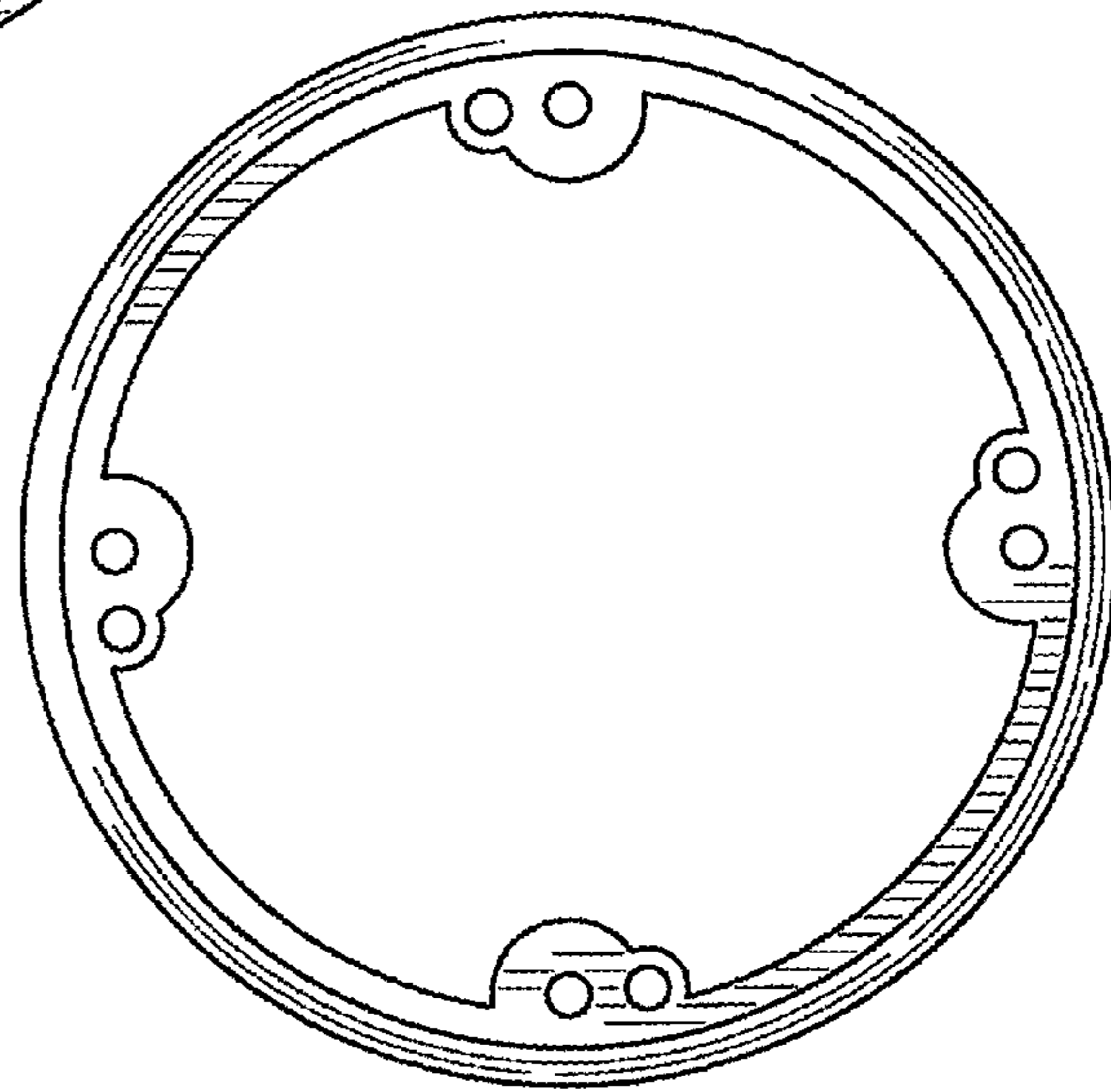

FIG. 2

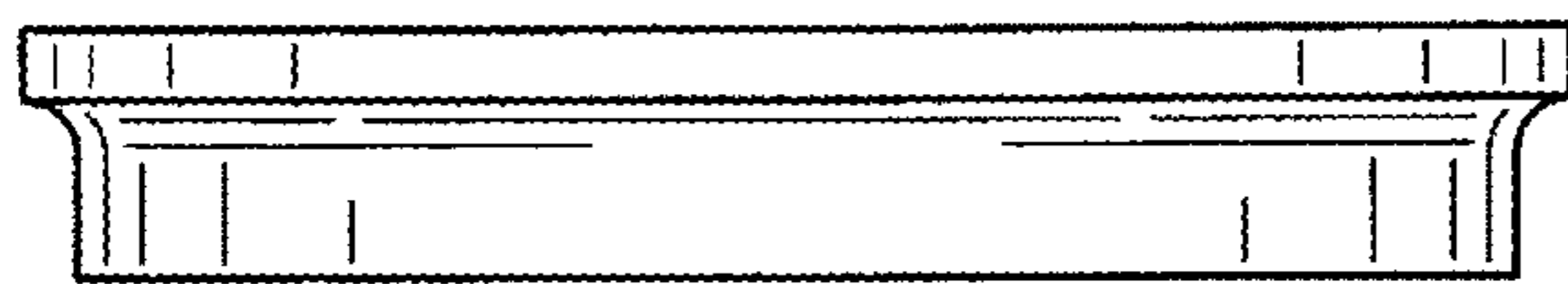

FIG. 3

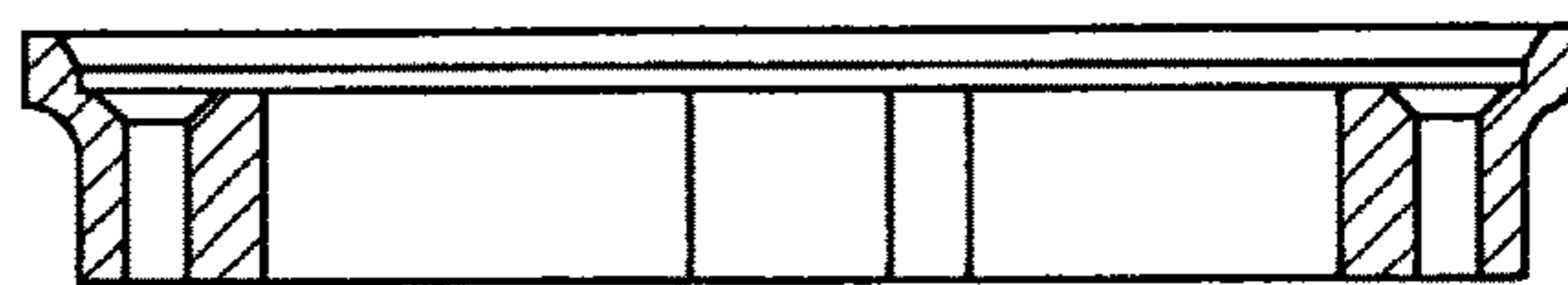

FIG. 4