

US00D750182S

(12) **United States Design Patent**  
**Takaoka et al.**

(10) **Patent No.:** **US D750,182 S**

(45) **Date of Patent:** **\*\* Feb. 23, 2016**

(54) **STATIONARY BIKE**

(71) Applicant: **Mitsubishi Electric Engineering Company, Ltd.**, Tokyo (JP)

(72) Inventors: **Shigeo Takaoka**, Tokyo (JP); **Hironori Suzuki**, Tokyo (JP); **Hongkue Lee**, Tokyo (JP)

(73) Assignee: **Mitsubishi Electric Engineering Company, Ltd.**, Tokyo (JP)

(\*\*) Term: **14 Years**

(21) Appl. No.: **29/497,601**

(22) Filed: **Jul. 25, 2014**

(30) **Foreign Application Priority Data**

Mar. 17, 2014 (JP) ..... 2014-005553

(51) **LOC (10) Cl.** ..... **21-02**

(52) **U.S. Cl.**  
USPC ..... **D21/663**

(58) **Field of Classification Search**  
USPC ..... D21/663, 667, 666, 697, 694, 665, 668,  
D21/664; 482/61, 57, 58, 127, 133, 51, 9,  
482/60, 904, 8, 1, 900, 63, 908; 188/24.11;  
74/502.4, 502.6, 551.1, 551.8;  
248/444.1, 205.1; D8/303; D12/178,  
D12/411

CPC .. A63B 22/0605; A63B 69/16; A63B 21/225;  
Y10T 74/2078; Y10T 74/20822

See application file for complete search history.

(56) **References Cited**

**U.S. PATENT DOCUMENTS**

D288,706 S \* 3/1987 Gremontez et al. .... D21/667  
D343,659 S \* 1/1994 Kiiski ..... D21/667

D406,288 S \* 3/1999 Chen ..... D21/663  
D433,082 S \* 10/2000 Tsushi ..... D21/663  
D480,119 S \* 9/2003 Chen ..... D21/663  
D675,687 S \* 2/2013 Fischer ..... D21/663

**OTHER PUBLICATIONS**

Commonly assigned co-pending U.S. Appl. No. 29/497,585, filed Jul. 25, 2014, entitled Room Exercise Machine.

Commonly assigned co-pending U.S. Appl. No. 29/532,940, filed Jul. 13, 2015, entitled Room Exercise Machine.

Commonly assigned co-pending U.S. Appl. No. 29/533,467, filed Jul. 17, 2015, entitled Room Exercise Machine.

\* cited by examiner

*Primary Examiner* — Robert M Spear

*Assistant Examiner* — Ryan Harvey

(74) *Attorney, Agent, or Firm* — Gardner, Linn, Burkhardt & Flory, LLP

(57) **CLAIM**

The ornamental design for a stationary bike, substantially as shown and described.

**DESCRIPTION**

FIG. 1 is a perspective view of a stationary bike, according to the present invention;

FIG. 2 is a front elevation view of the stationary bike of FIG. 1;

FIG. 3 is a rear elevation view of the stationary bike of FIG. 1; FIG. 4 is a left-side elevation view of the stationary bike of FIG. 1;

FIG. 5 is a right-side elevation view of the stationary bike of FIG. 1;

FIG. 6 is a top plan view of the stationary bike of FIG. 1; and, FIG. 7 is a bottom plan view of the stationary bike of FIG. 1.

The broken lines shown in FIG. 7 are included for the purpose of illustrating environment and form no part of the claimed design.

**1 Claim, 7 Drawing Sheets**

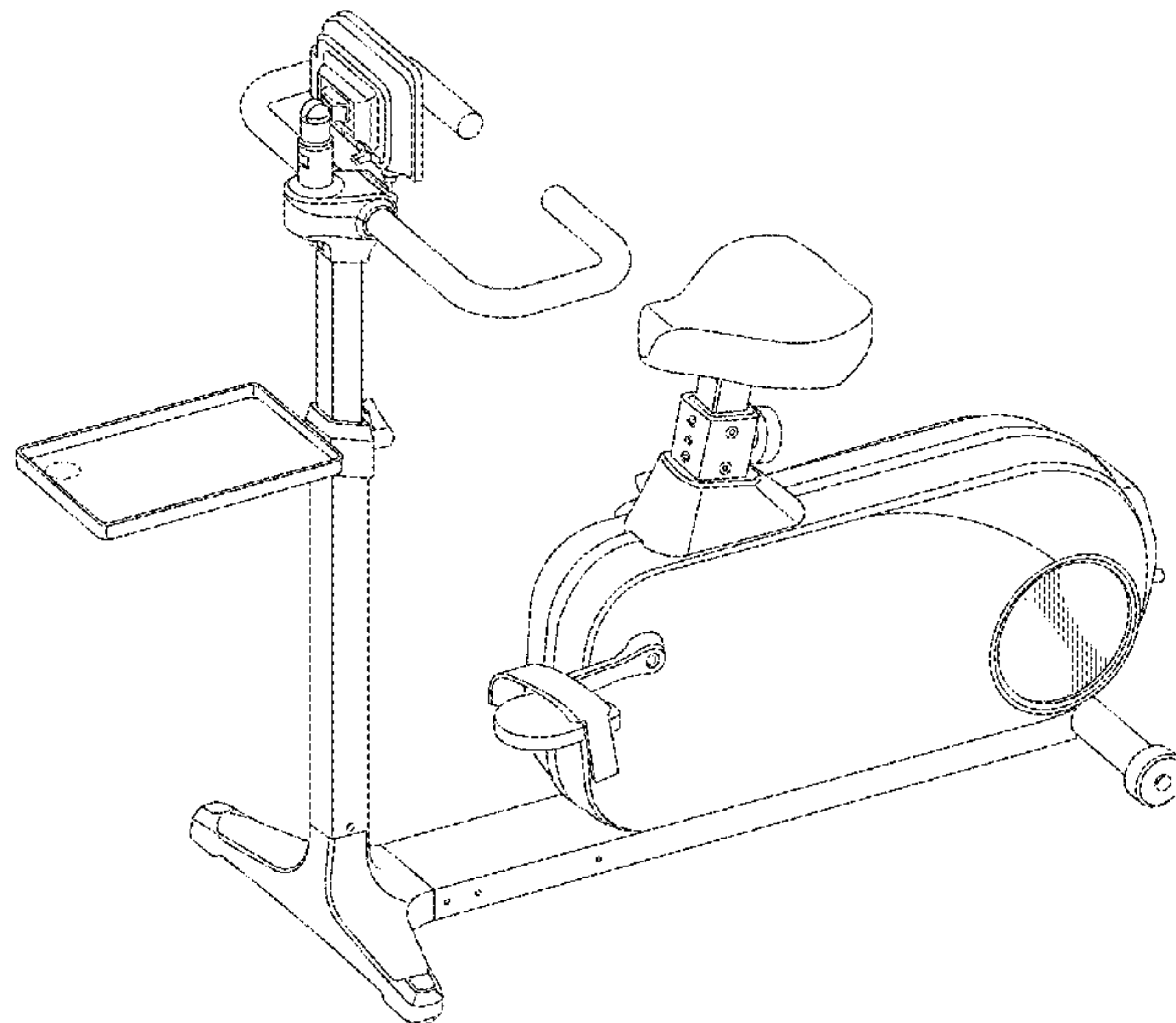

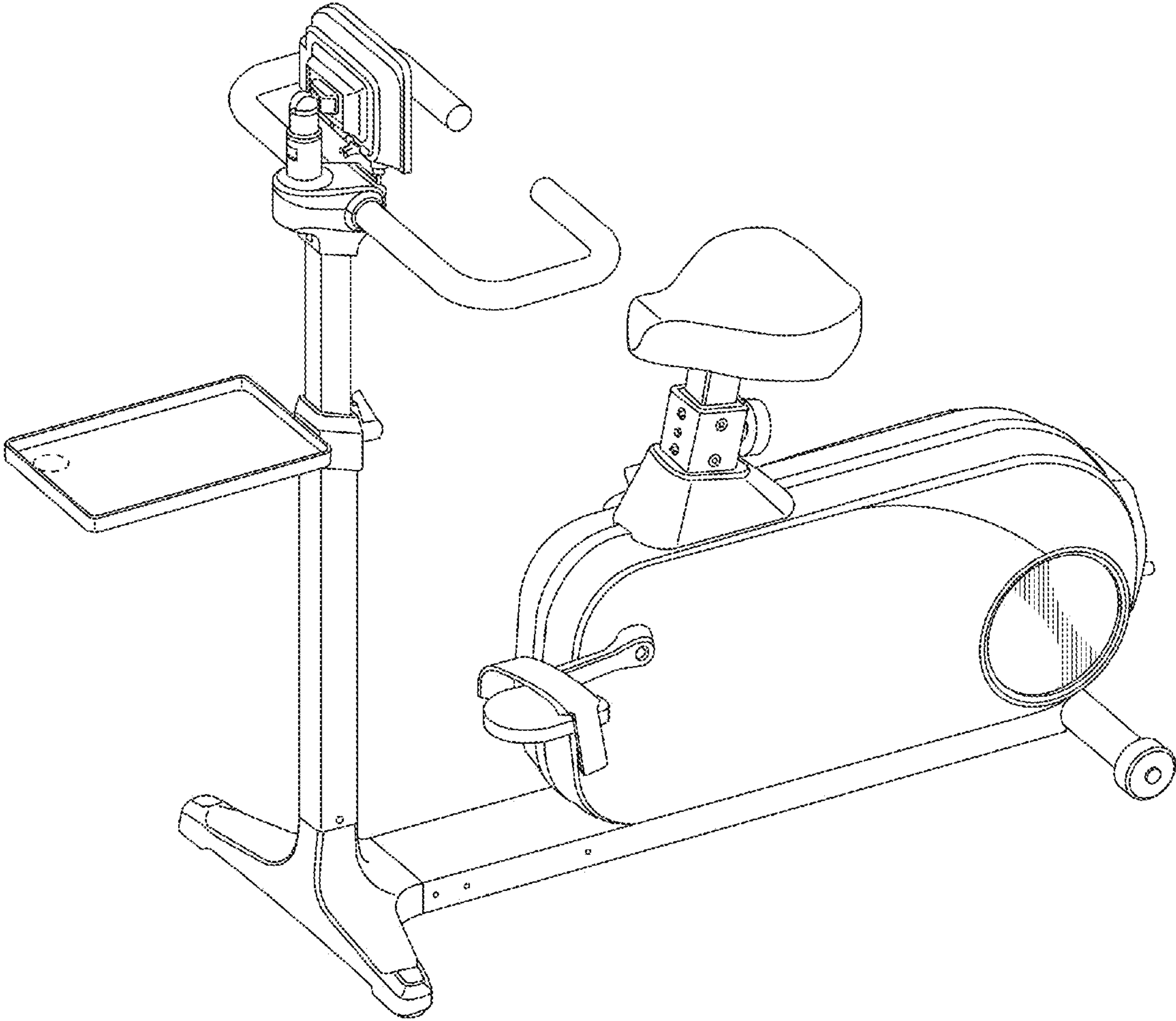

FIG. 1

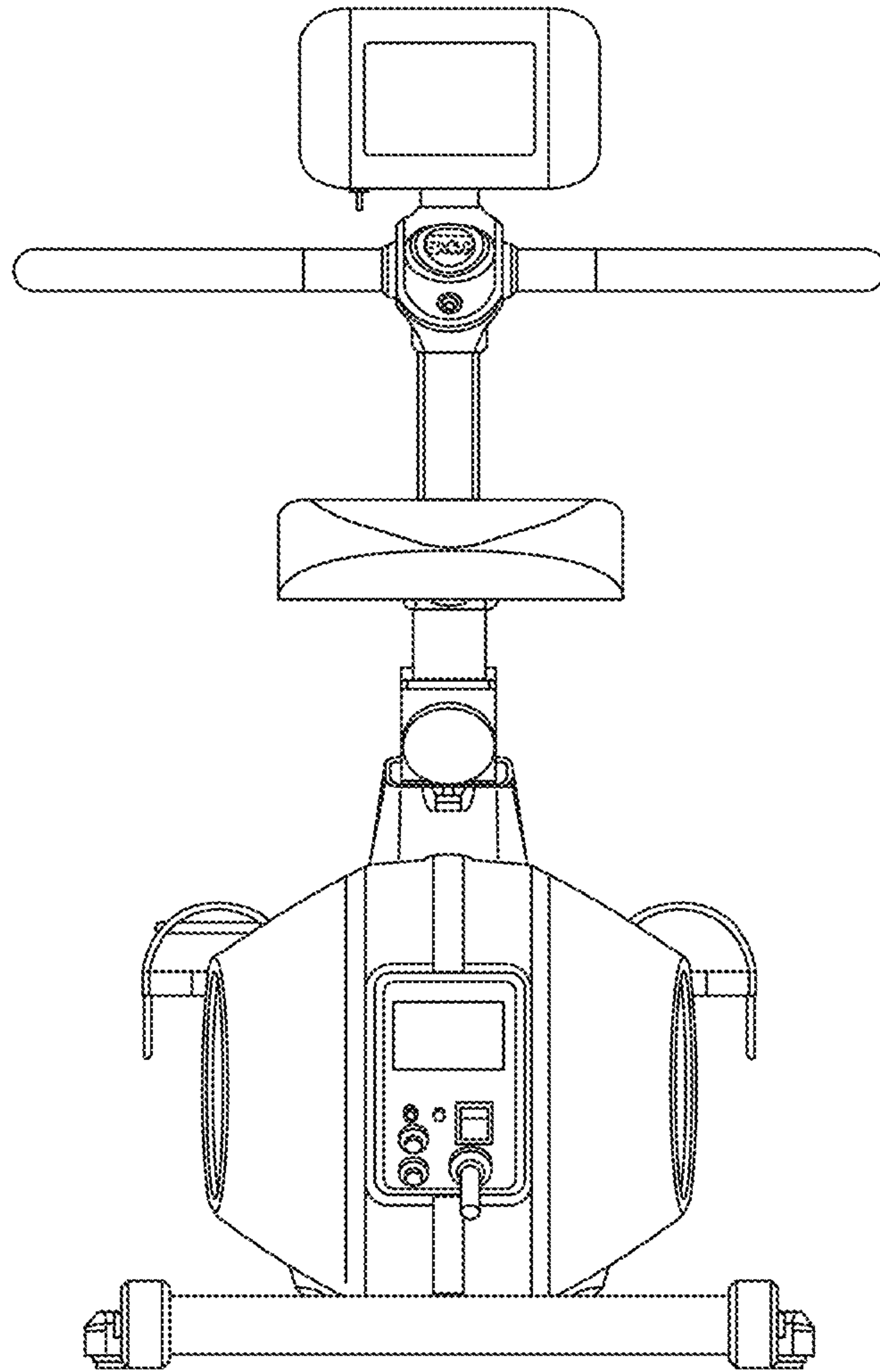

FIG. 2

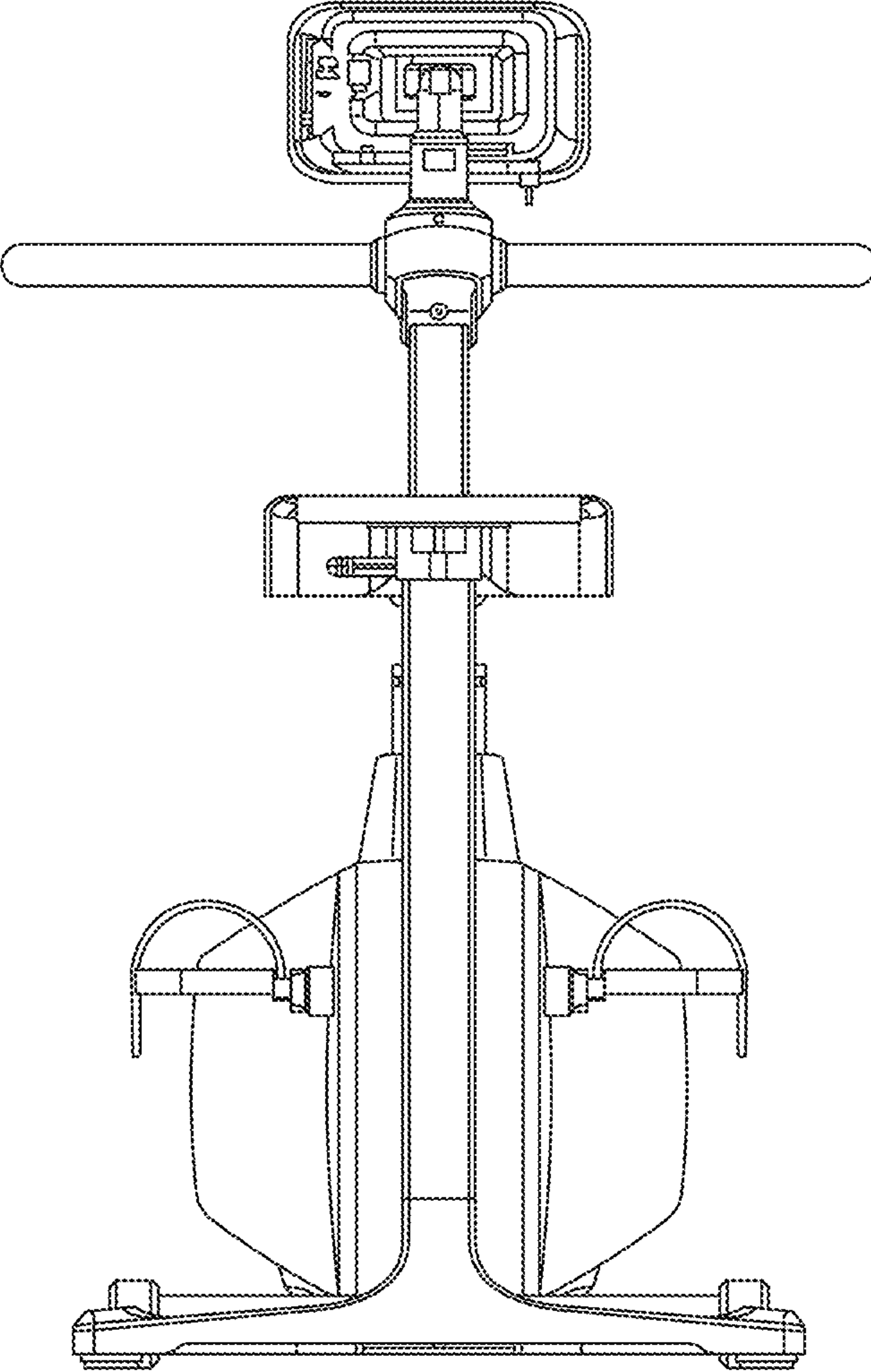

FIG. 3

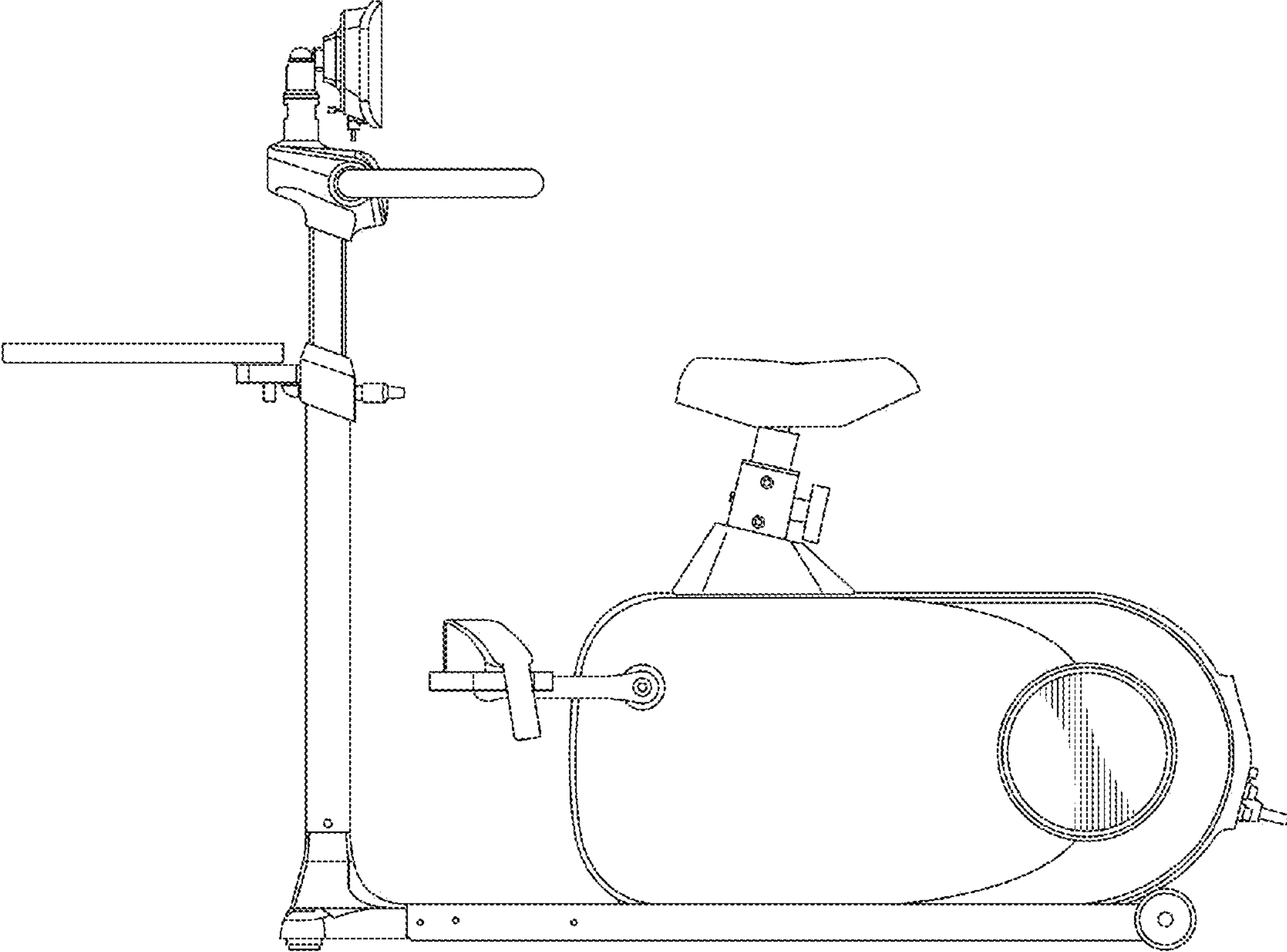

FIG. 4



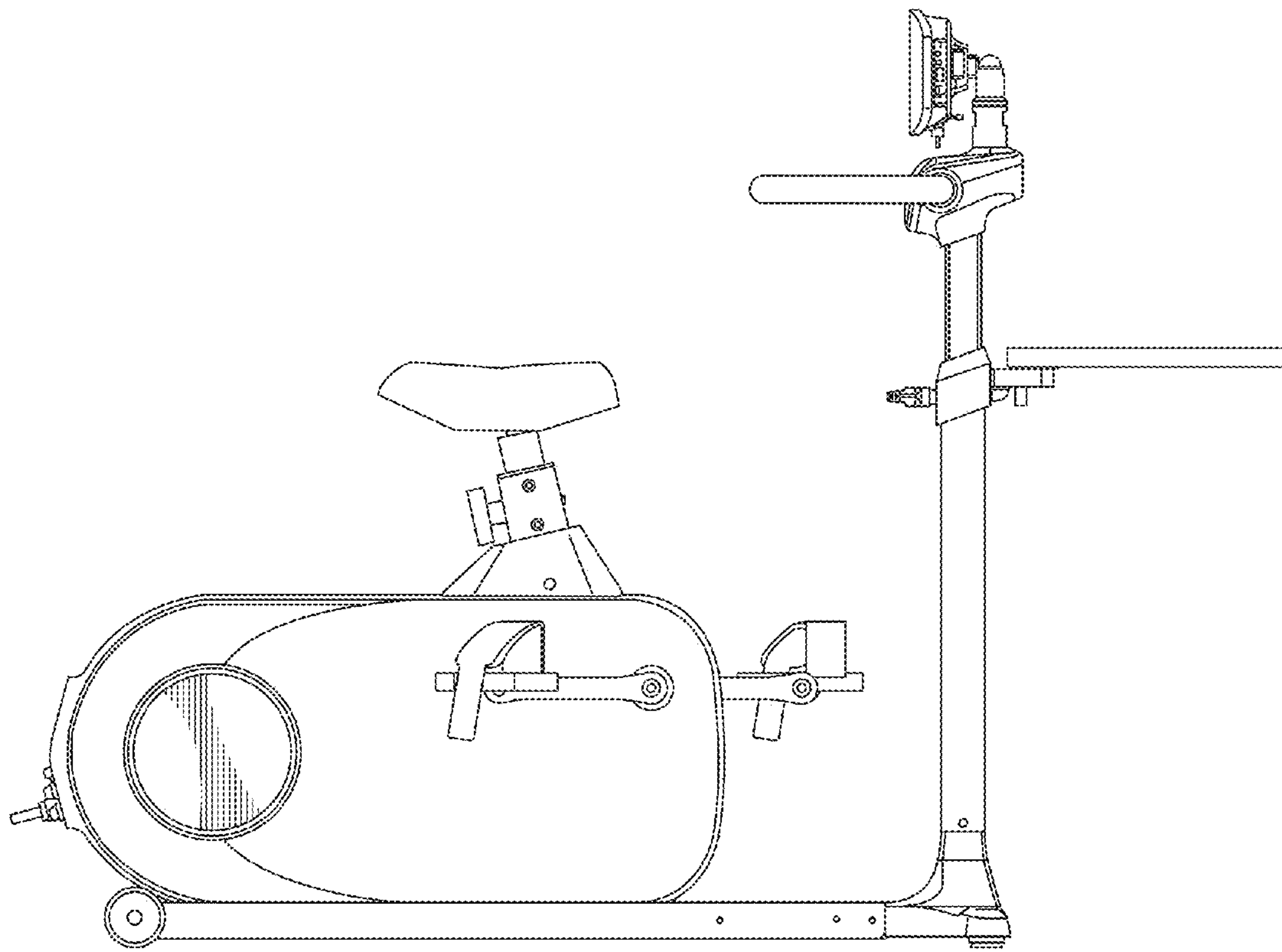

FIG. 5

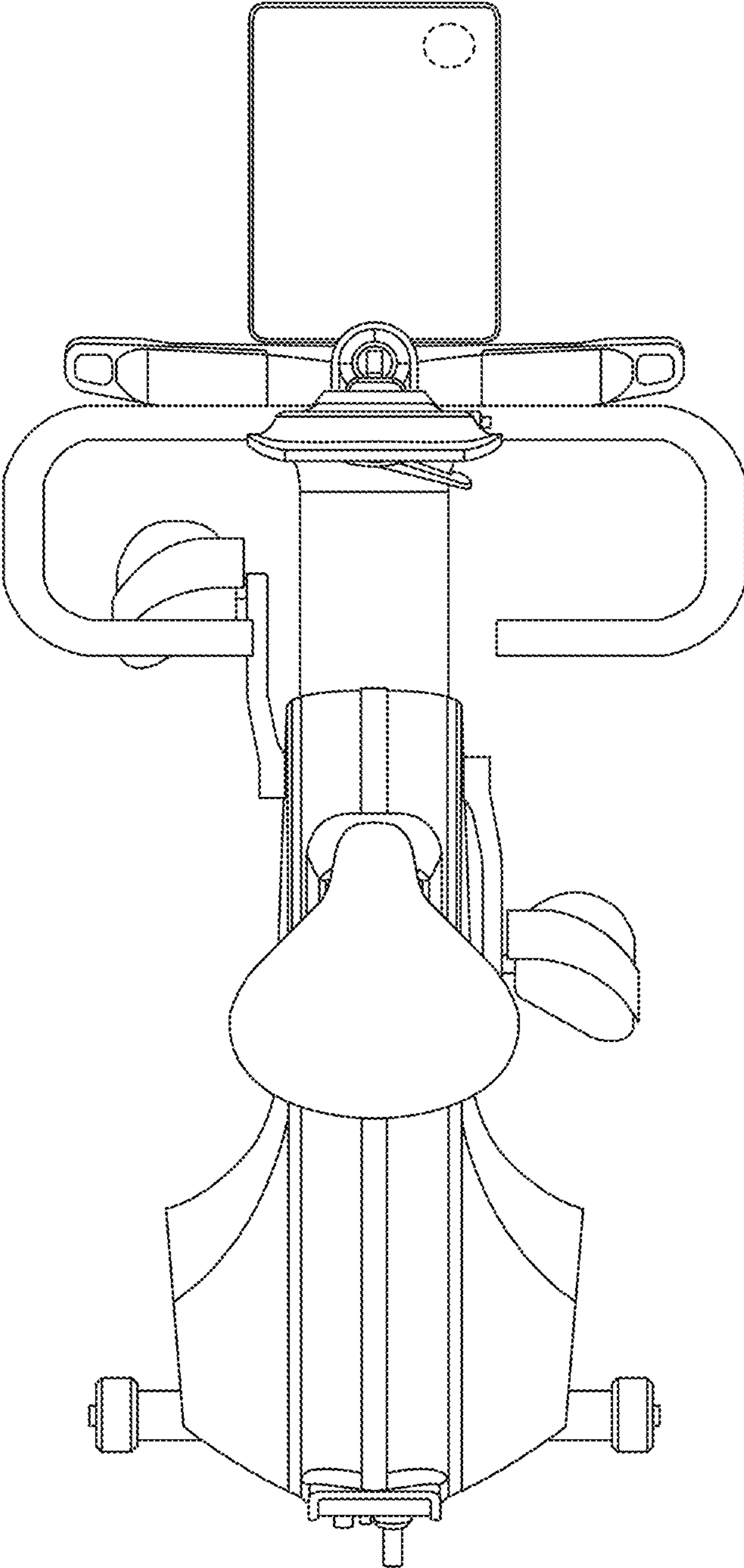

FIG. 6

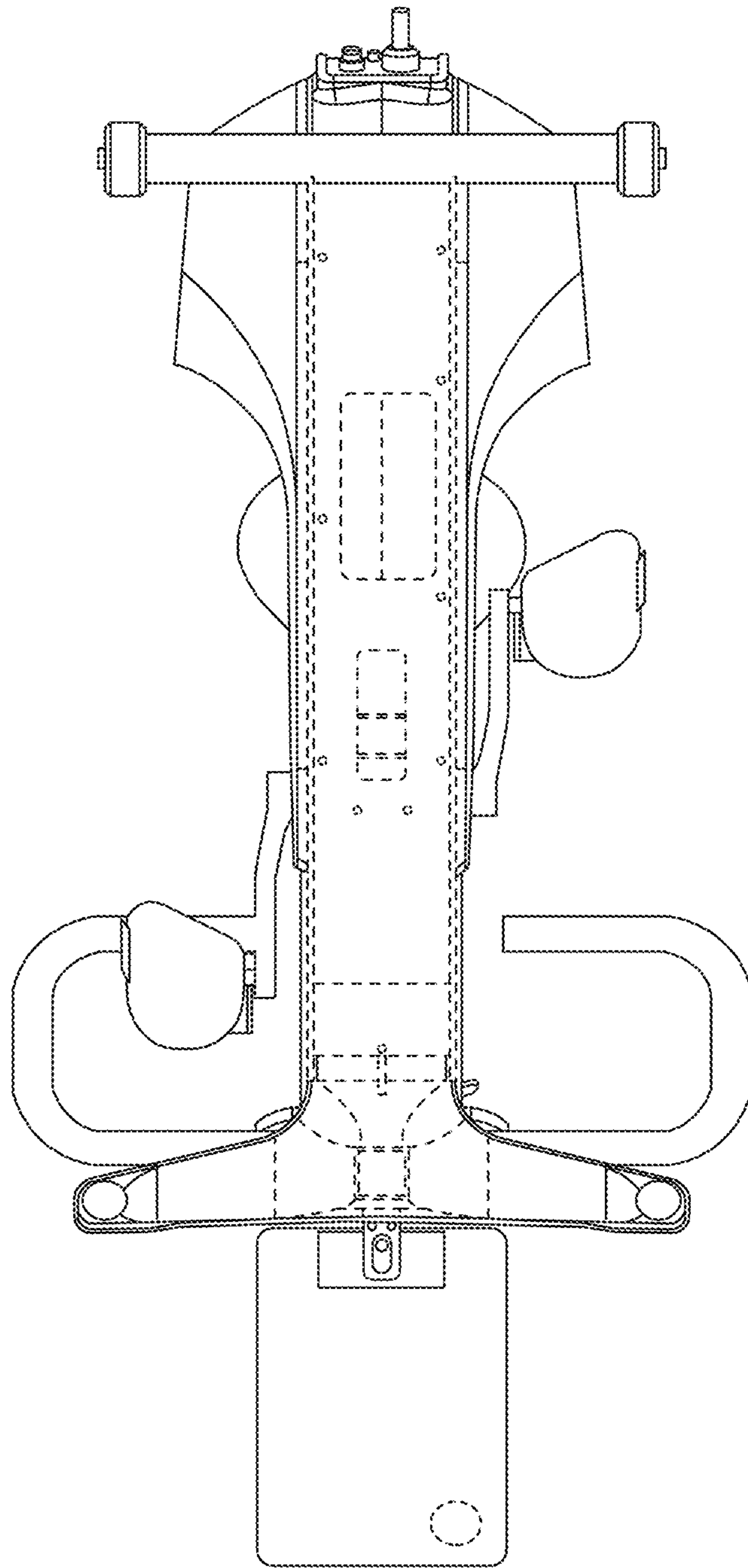

FIG. 7