



US00D750162S

(12) **United States Design Patent**
Ozawa et al.

(10) **Patent No.:** **US D750,162 S**
(45) **Date of Patent:** **** Feb. 23, 2016**

(54) **LABEL PRINTER**

(56) **References Cited**

(71) Applicant: **SATO HOLDINGS KABUSHIKI**
KAISHA, Tokyo (JP)

U.S. PATENT DOCUMENTS

(72) Inventors: **Taichi Ozawa**, Tokyo (JP); **Keita Kuramochi**, Tokyo (JP); **Yasuyuki Kakui**, Tokyo (JP)

D362,673	S	*	9/1995	Yamamoto	D18/19
6,236,486	B1	*	5/2001	Nocker, IV	398/129
D528,151	S	*	9/2006	Hattori	D18/50
D528,587	S	*	9/2006	Nakaeda	D18/19
7,285,042	B2	*	10/2007	Kato	400/691
D579,043	S	*	10/2008	Hattori et al.	D18/50
D641,394	S	*	7/2011	Inada	D18/50
D689,542	S	*	9/2013	Klocke et al.	D18/50
D694,319	S	*	11/2013	Nakagawa	D18/50
D720,397	S	*	12/2014	Hirabayashi et al.	D18/50

(73) Assignee: **SATO HOLDINGS KABUSHIKI**
KAISHA, Tokyo (JP)

(**) Term: **14 Years**

FOREIGN PATENT DOCUMENTS

(21) Appl. No.: **29/494,803**

JP 1491367 * 3/2014

(22) Filed: **Jun. 24, 2014**

* cited by examiner

(30) **Foreign Application Priority Data**

Dec. 25, 2013 (JP) 2013-030360

(51) **LOC (10) CL.** **14-02**

(52) **U.S. CL.**
USPC **D18/50; D18/19**

(58) **Field of Classification Search**
USPC D18/14, 19, 50, 53, 54, 54.1, 55, 4.1,
D18/4.3-4.5; D14/420-425, 462-470;
400/613, 613.1-613.4, 690.1-690.4,
400/691-694
CPC B41J 1/46; B41J 3/36; B41J 9/26;
B41J 15/00; B41J 29/02; B41J 29/13; B41J
35/36; B41J 11/00; B41J 11/20; B41J 29/00;
B41J 3/39; B41J 11/26; B65H 35/06; G03G
15/00; G03G 21/00; G03G 21/16; G06F 3/12;
G06K 15/14; H05B 10/00; H05K 5/00

See application file for complete search history.

(57) **CLAIM**
The ornamental design for a label printer, as shown and described.

DESCRIPTION

FIG. 1 is a front perspective view of the present invention. FIG. 2 is a front elevation view of FIG. 1. FIG. 3 is a rear elevation view of FIG. 1. FIG. 4 is a top plan view of FIG. 1. FIG. 5 is a bottom plan view of FIG. 1. FIG. 6 is a right side elevation view of FIG. 1; and, FIG. 7 is a left side elevation view of FIG. 1. The broken lines depict environmental subject matter that forms no part of the claimed design. The dash-dot-dash broken lines define the boundary between the claimed and non-claimed subject matter, and form no part of the claimed design.

1 Claim, 7 Drawing Sheets

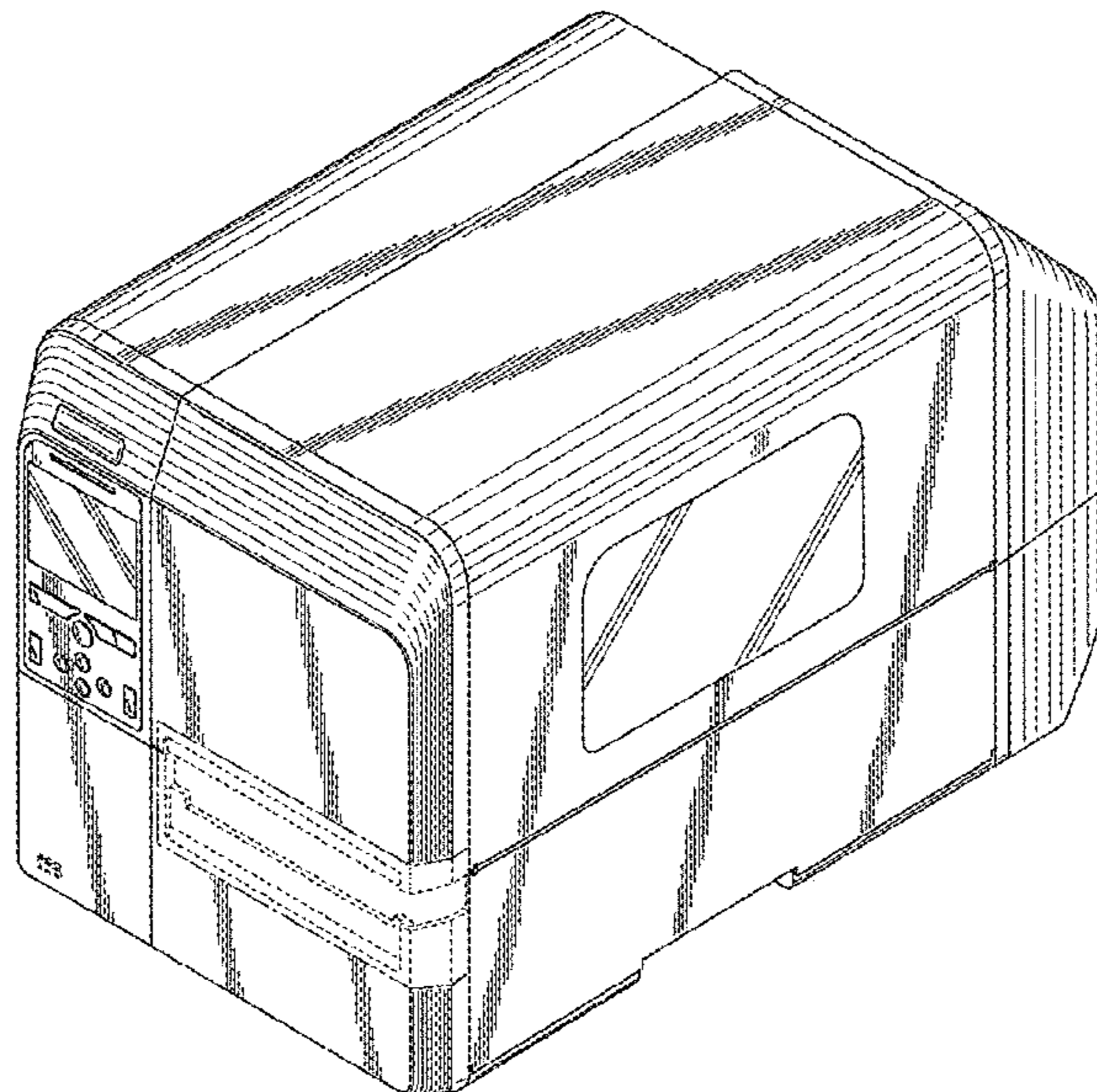

FIG. 1

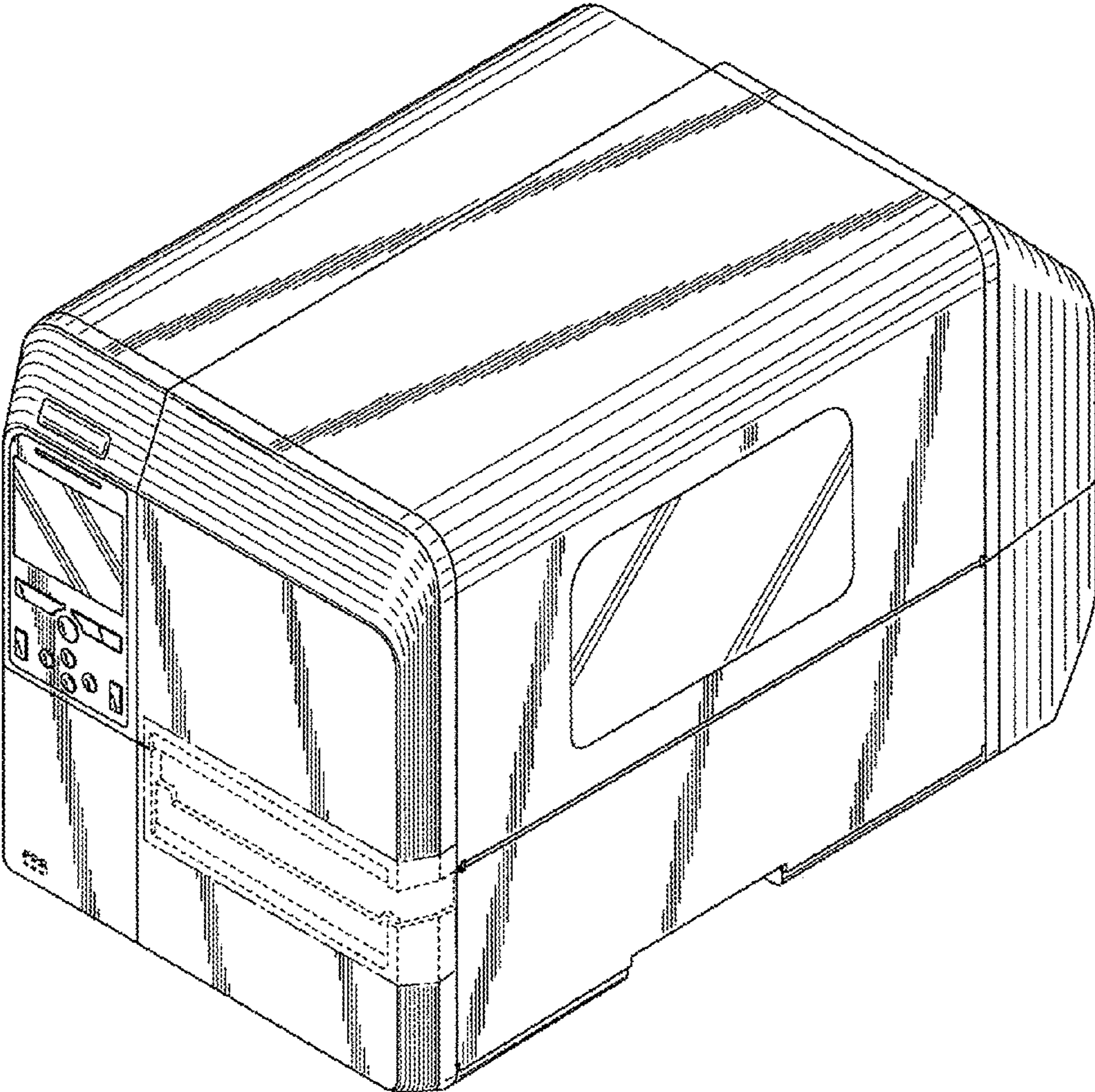

FIG. 2

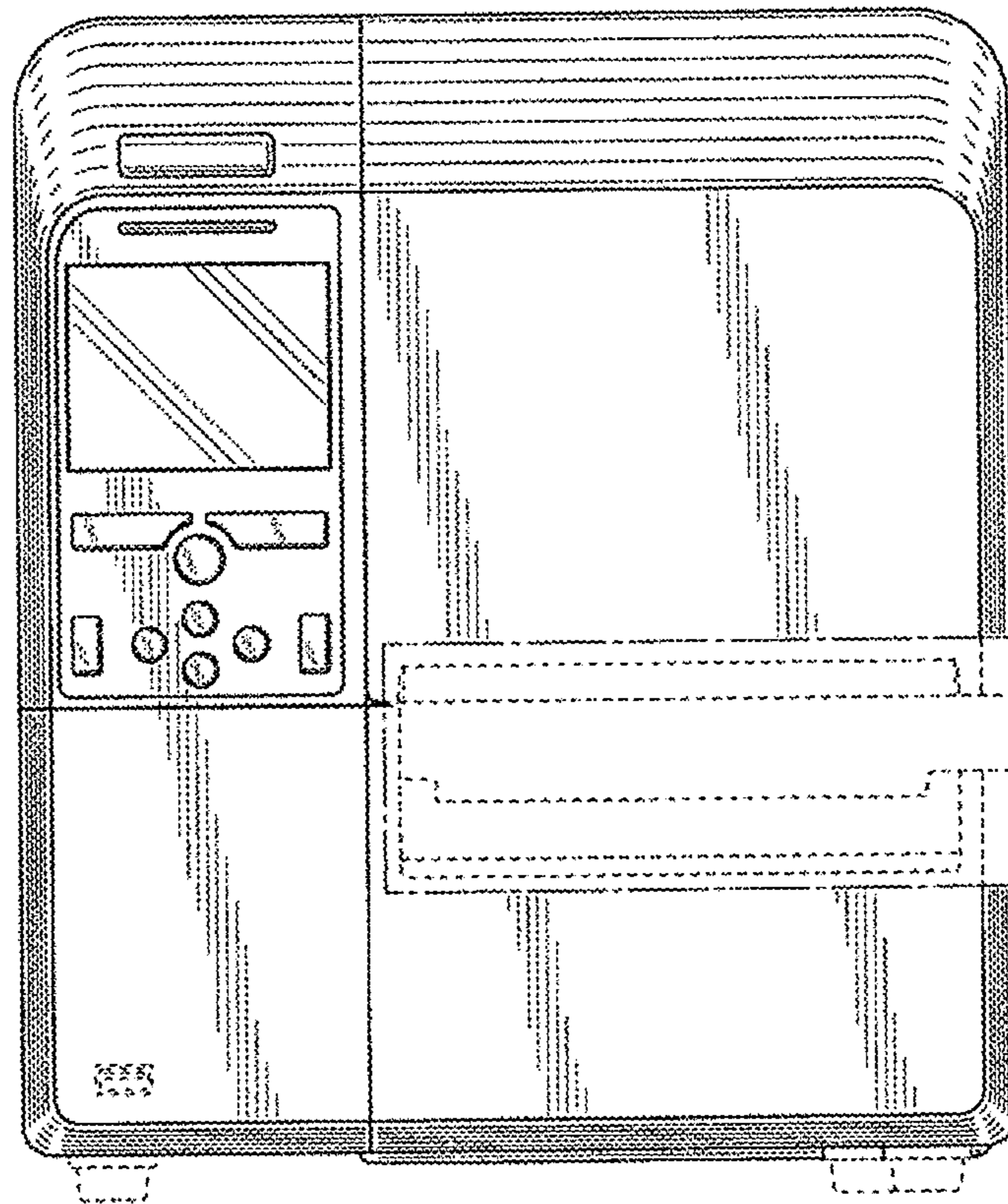

FIG. 3

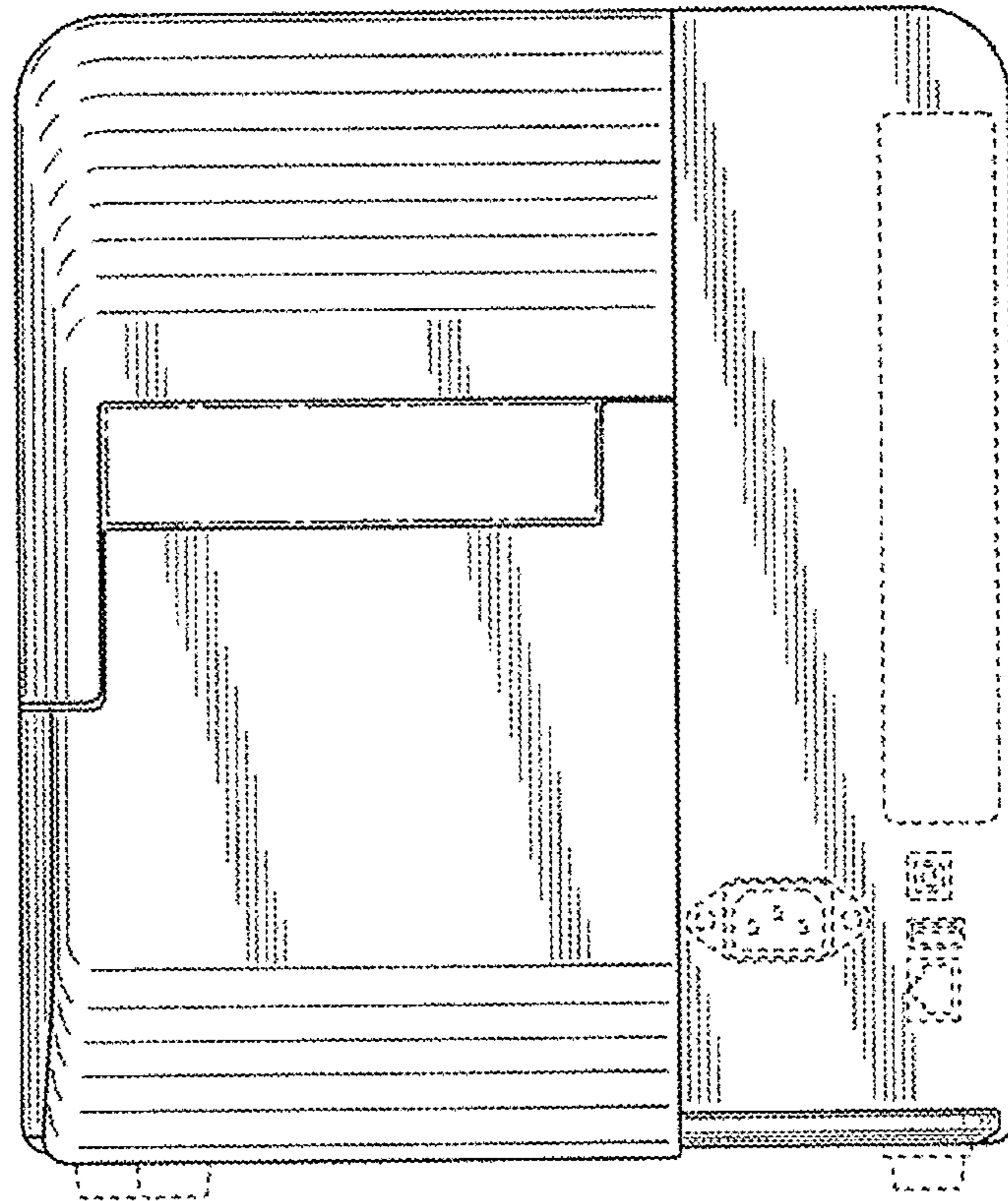

FIG. 4

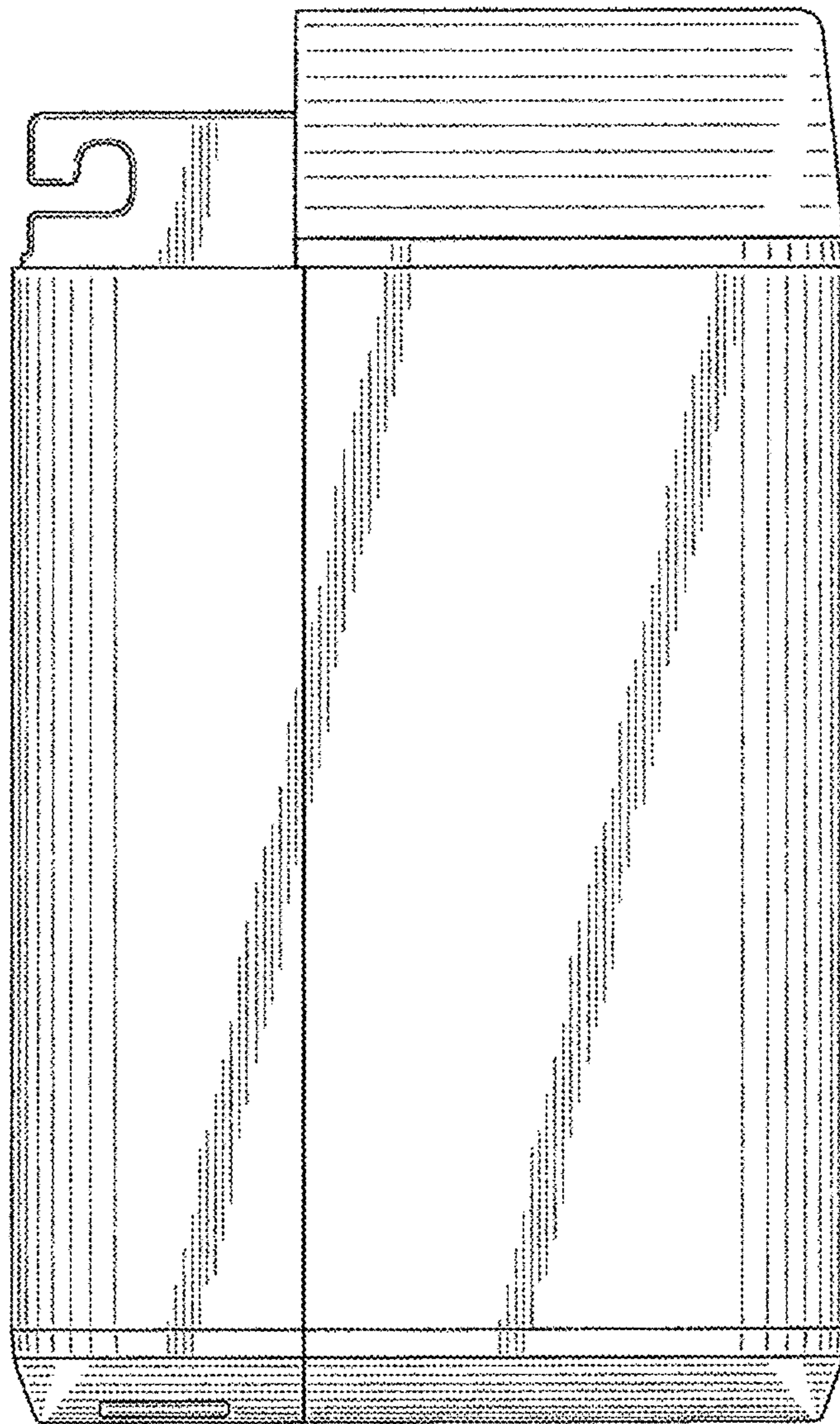

FIG. 5

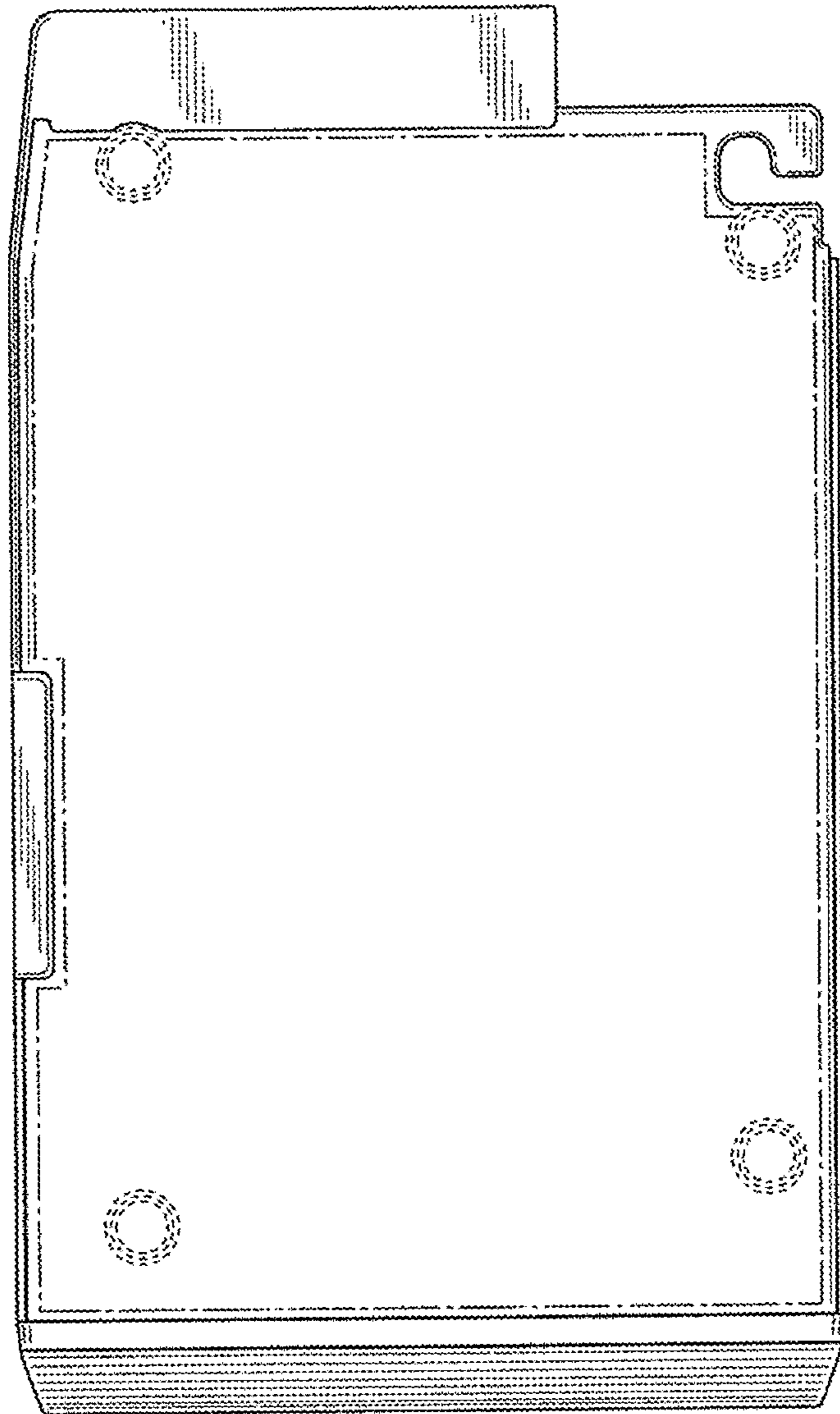

FIG. 6

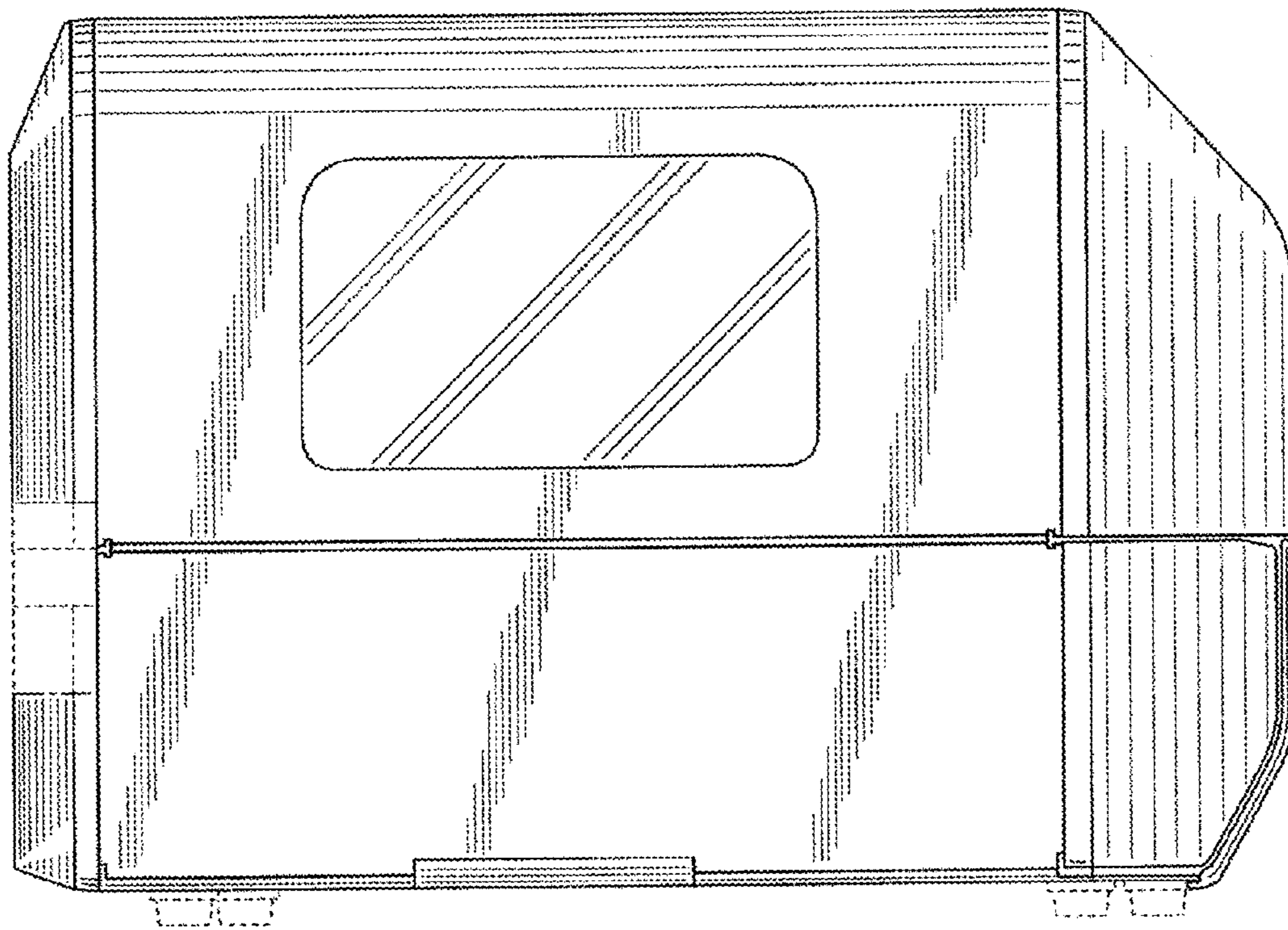

FIG. 7

