



US00D750144S

(12) **United States Design Patent**  
**Stephens et al.**

(10) **Patent No.:** **US D750,144 S**

(45) **Date of Patent:** **\*\* \*Feb. 23, 2016**

(54) **ELECTRODE HOLDER**

(71) Applicant: **Victor Equipment Company**, Denton, TX (US)

(72) Inventors: **Mike Stephens**, The Colony, TX (US);  
**Glenn K. Redding**, Flower Mound, TX (US); **Indy Datta**, Denton, TX (US)

(73) Assignee: **Victor Equipment Company**, Denton, TX (US)

(\*) Notice: This patent is subject to a terminal disclaimer.

(\*\*) Term: **14 Years**

(21) Appl. No.: **29/495,234**

(22) Filed: **Jun. 27, 2014**

(51) **LOC (10) Cl.** ..... **15-09**

(52) **U.S. Cl.**  
USPC ..... **D15/144**

(58) **Field of Classification Search**  
USPC ..... D8/30; D15/144, 144.1, 144.2  
See application file for complete search history.

(56) **References Cited**

**U.S. PATENT DOCUMENTS**

2,067,230	A *	1/1937	Bowers	.....	219/138
2,375,657	A *	5/1945	Jackson	.....	219/138
2,384,999	A *	9/1945	Heinrich	.....	219/138
2,386,399	A *	10/1945	Jackson	.....	219/138
2,401,523	A *	6/1946	Townsend	.....	219/138
2,404,125	A *	7/1946	Donnelly, Jr.	.....	219/138
2,415,671	A *	2/1947	Camilleri	.....	219/138
2,449,370	A *	9/1948	Donnelly	.....	219/138

2,477,207	A *	7/1949	Rinehart	.....	219/138
2,681,969	A *	6/1954	Burke	.....	219/138
2,692,933	A *	10/1954	Cornell	.....	219/138
2,799,771	A *	7/1957	Donnelly, Jr.	.....	219/138
2,899,536	A *	8/1959	Hoese et al.	.....	219/70
3,140,386	A *	7/1964	Cartwright	.....	219/138
3,356,823	A *	12/1967	Waters et al.	.....	219/138
3,659,072	A *	4/1972	Carkhuff et al.	.....	219/70
D417,828	S *	12/1999	Amin	.....	D8/30
D419,044	S *	1/2000	Amin	.....	D8/30
D419,408	S *	1/2000	Amin	.....	D8/30
D419,838	S *	2/2000	Amin	.....	D8/30
D422,186	S *	4/2000	Amin	.....	D8/30
D424,388	S *	5/2000	Amin	.....	D8/30
D615,573	S *	5/2010	Peters et al.	.....	D15/144

\* cited by examiner

*Primary Examiner* — Patricia Palasik

(74) *Attorney, Agent, or Firm* — Kacvinsky Daisak Bluni PLLC

(57) **CLAIM**

The ornamental design for an electrode holder, as shown and described.

**DESCRIPTION**

FIG. 1 is a top perspective view of the electrode holder; FIG. 2 is another top perspective view thereof; FIG. 3 is a side view thereof; FIG. 4 is another side view thereof; FIG. 5 is a front view thereof; FIG. 6 is a rear view thereof; FIG. 7 is a top view thereof; and, FIG. 8 is a bottom view thereof. The broken lines in the drawings depict unclaimed environmental subject matter.

**1 Claim, 8 Drawing Sheets**

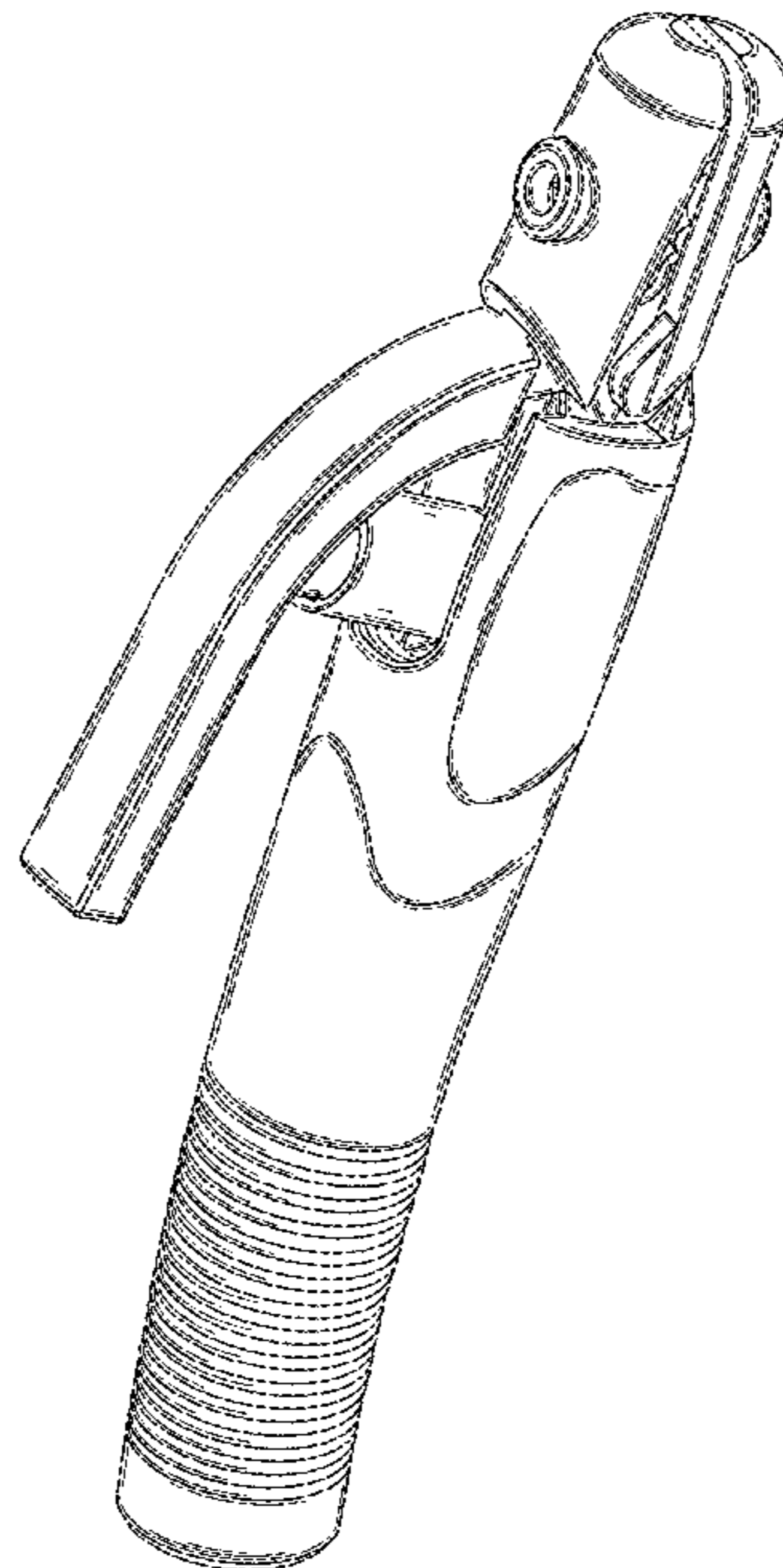

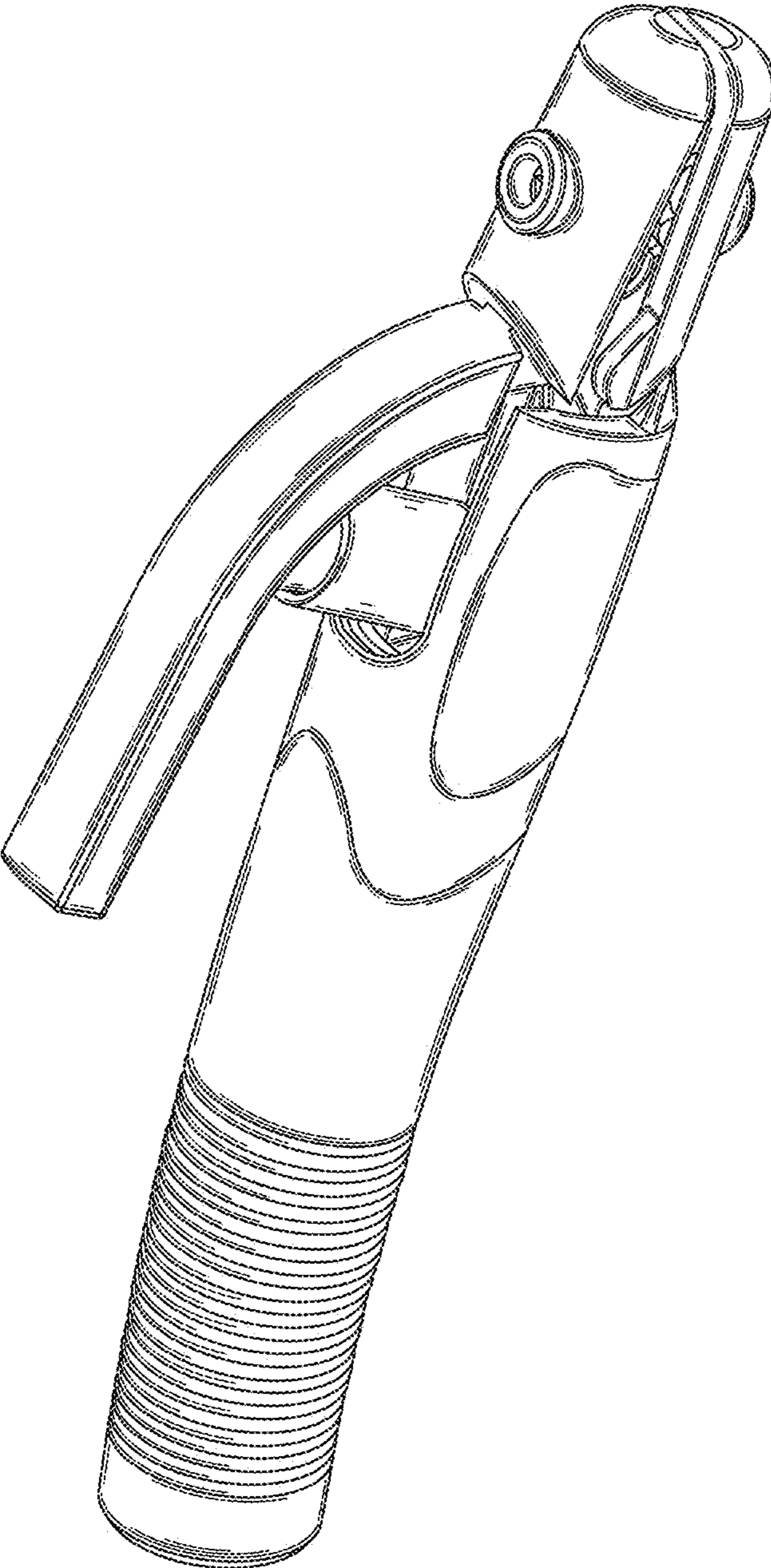

FIG. 1

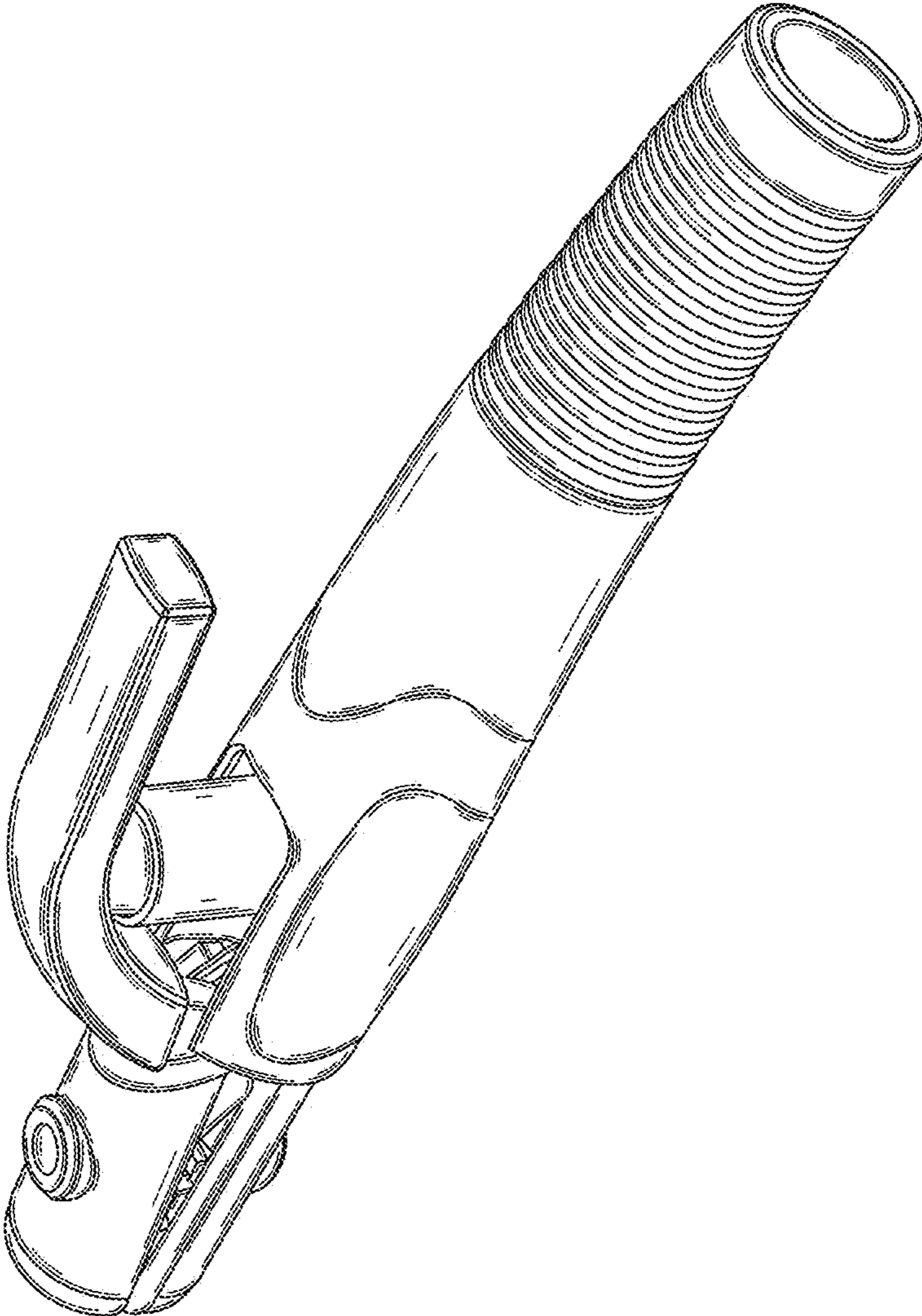

FIG. 2

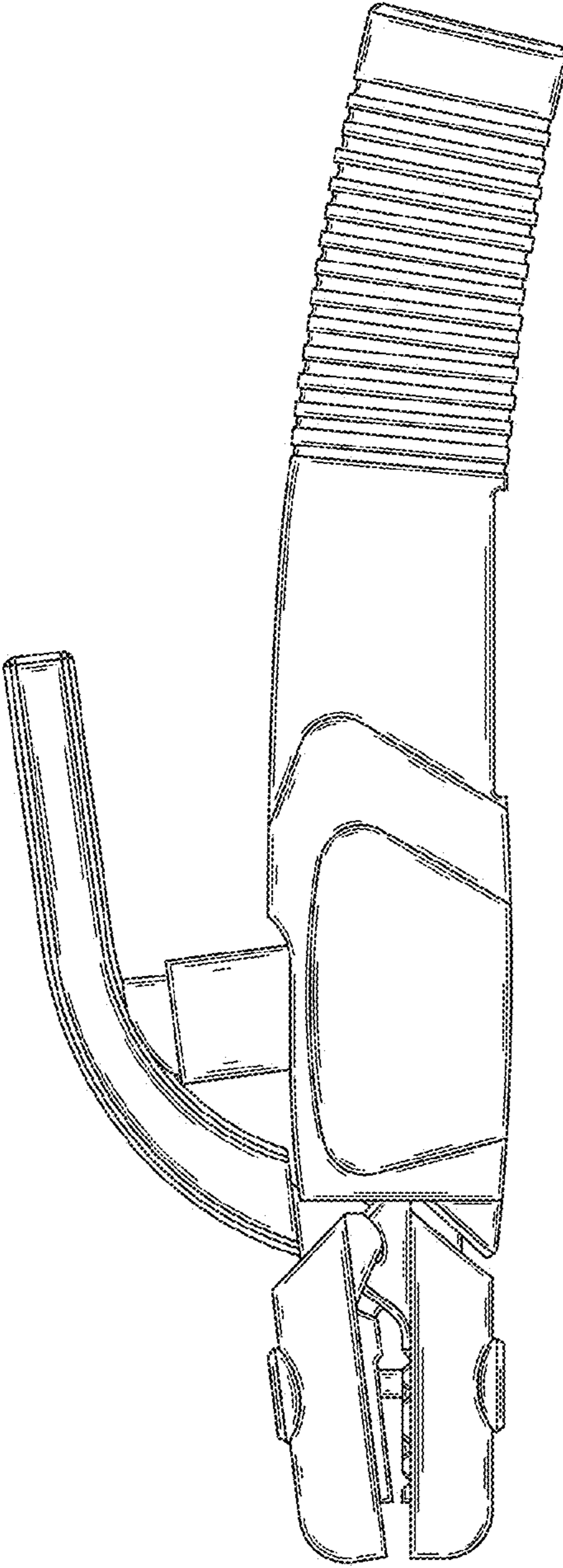

FIG. 3

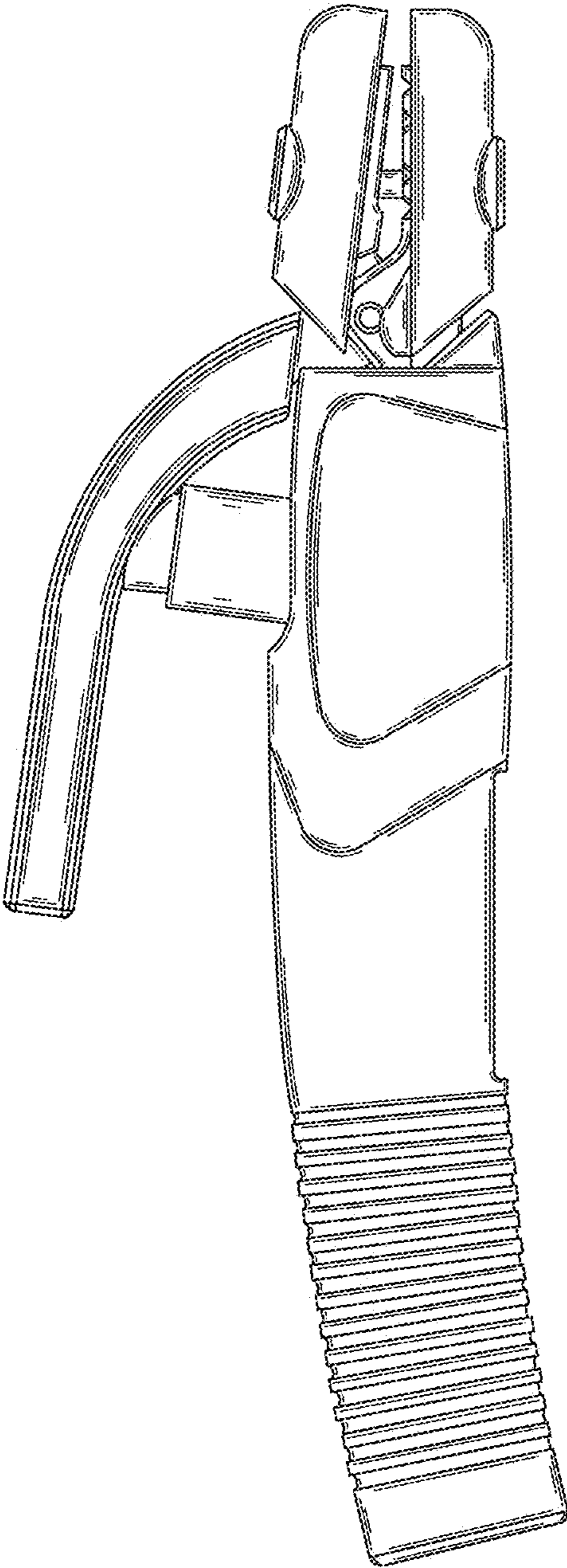

FIG. 4

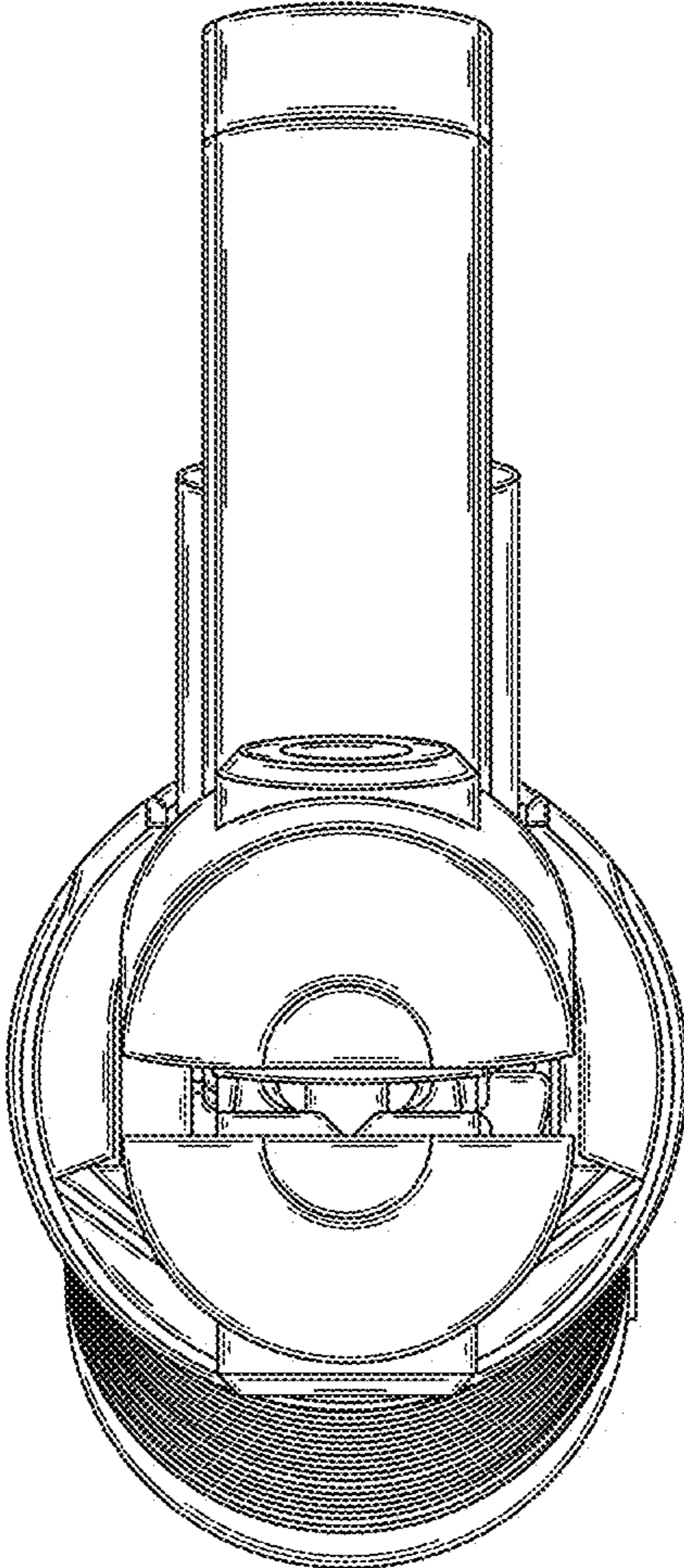
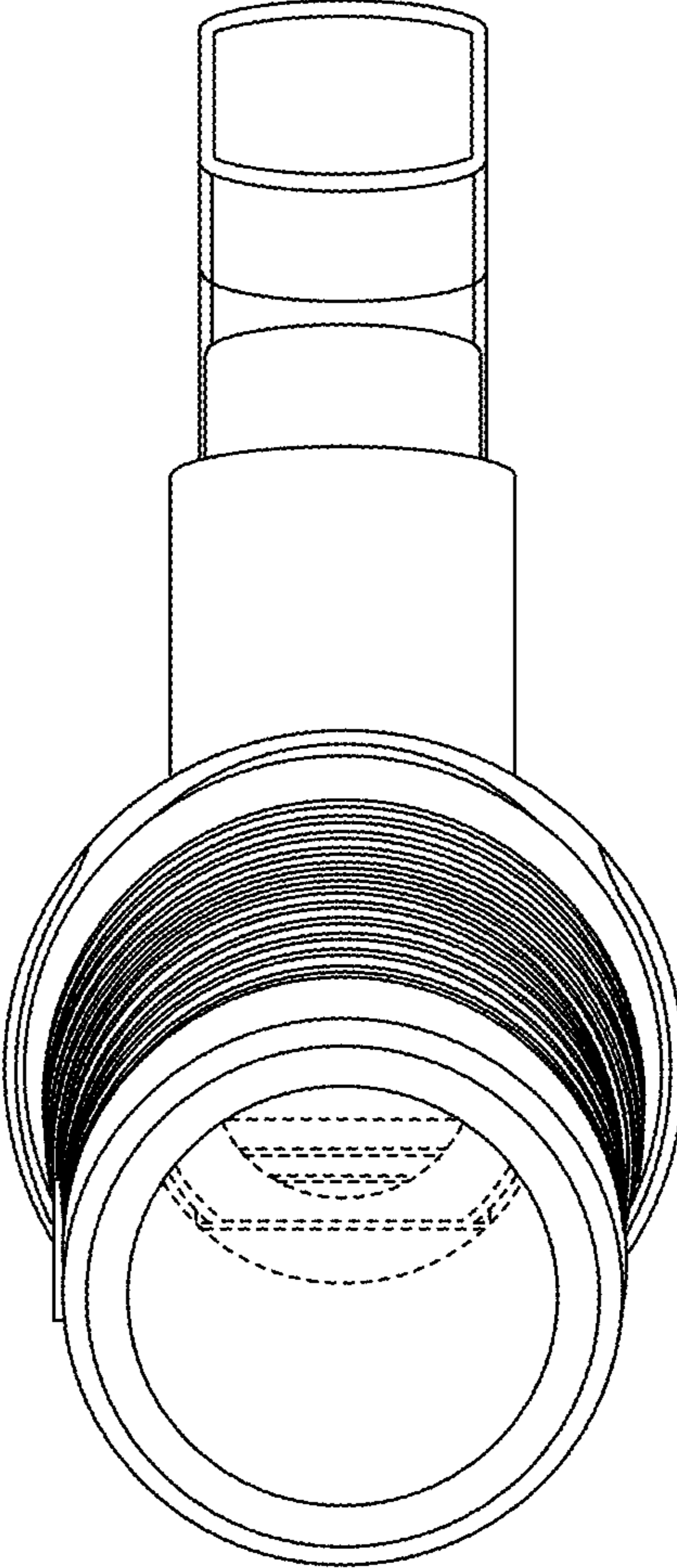

FIG. 5



**FIG. 6**

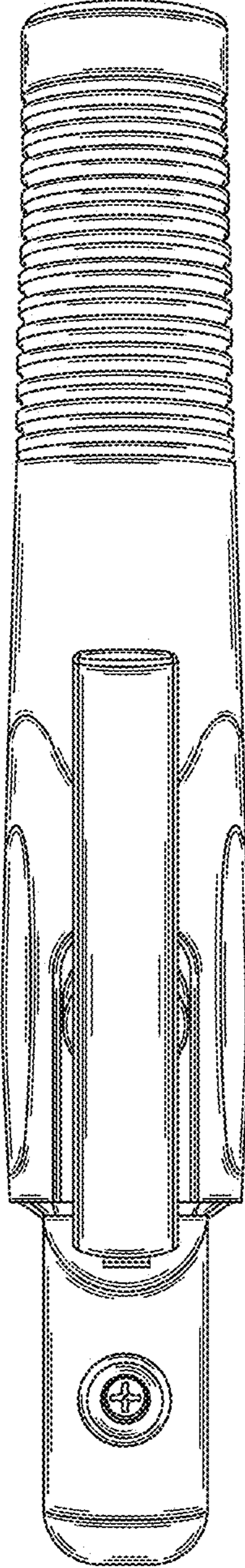

FIG. 7



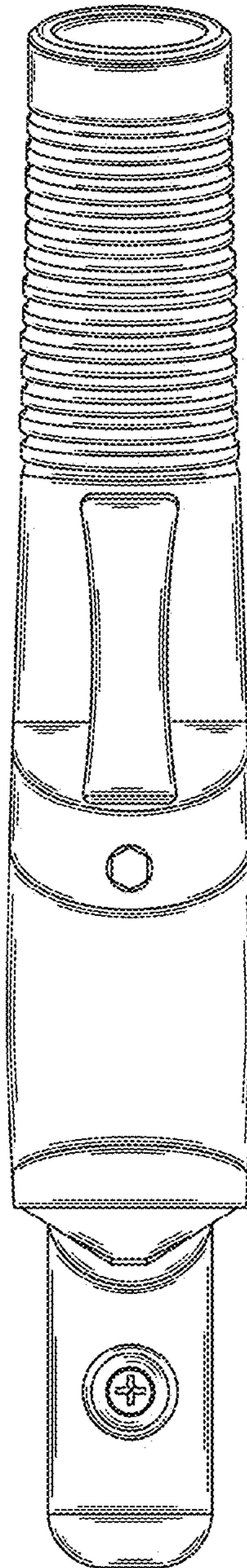

FIG. 8