



US00D750029S

(12) **United States Design Patent**  
**Zhu et al.**

(10) **Patent No.:** **US D750,029 S**  
(45) **Date of Patent:** **\*\* Feb. 23, 2016**

(54) **CABLE CONNECTOR**

(71) Applicant: **Wuxi Huahao Electric Co., Ltd**, Wuxi, Jiangsu (CN)

(72) Inventors: **Hao Zhu**, Jiangsu (CN); **Shaohua Gu**, Jiangsu (CN)

(73) Assignee: **Wuxi Huahao Electric Co., Ltd**, Wuxi, Jiangsu (CN)

(\*\*) Term: **14 Years**

(21) Appl. No.: **29/522,216**

(22) Filed: **Mar. 27, 2015**

(30) **Foreign Application Priority Data**

Dec. 16, 2014 (CN) ..... 2014 3 0530167

(51) **LOC (10) Cl.** ..... **13-03**

(52) **U.S. Cl.**  
USPC ..... **D13/151**

(58) **Field of Classification Search**

USPC ..... D13/129, 133, 149, 151, 153-156, 184, D13/199; 439/271, 275, 277, 283, 285, 439/279 R, 282; 174/650, 656, 665, 659; D8/348, 355

CPC ..... H01R 4/10; H01R 4/18; H01R 4/38; H01R 4/40; H01R 4/56; H01R 4/60; H01R 4/64

See application file for complete search history.

(56) **References Cited**

U.S. PATENT DOCUMENTS

D227,373	S	*	6/1973	McLean, Jr.	.....	D13/149
D243,405	S	*	2/1977	Mooney	.....	D13/149
D243,407	S	*	2/1977	Mooney	.....	D13/149
D251,972	S	*	5/1979	Malocsay	.....	D13/151
D301,459	S	*	6/1989	Chambers	.....	D13/151
D325,899	S	*	5/1992	Krokaugger	.....	D13/151
D329,043	S	*	9/1992	Rogers	.....	D13/155
D334,914	S	*	4/1993	Walter	.....	D13/147
D397,090	S	*	8/1998	Gray	.....	D13/155
D458,592	S	*	6/2002	Gust	.....	D13/155
D530,678	S	*	10/2006	Kiely	.....	D13/149
D657,316	S	*	4/2012	Kiely	.....	D13/149
D666,153	S	*	8/2012	Smith	.....	D13/149
D668,617	S	*	10/2012	Kiely	.....	D13/149
D731,982	S	*	6/2015	Sorensen	.....	D13/129
D733,064	S	*	6/2015	Smith	.....	D13/149

\* cited by examiner

*Primary Examiner* — Derrick Holland

*Assistant Examiner* — Jennifer O King

(57) **CLAIM**

The ornamental design for a cable connector, as shown and described.

**DESCRIPTION**

FIG. 1 is a perspective view of a cable connector, showing our new design.

FIG. 2 is a front elevational view thereof.

FIG. 3 is a rear elevational view thereof.

FIG. 4 is a left side elevational view thereof.

FIG. 5 is a right side elevational view thereof.

FIG. 6 is a top plan view thereof; and,

FIG. 7 is a bottom plan view thereof.

**1 Claim, 7 Drawing Sheets**

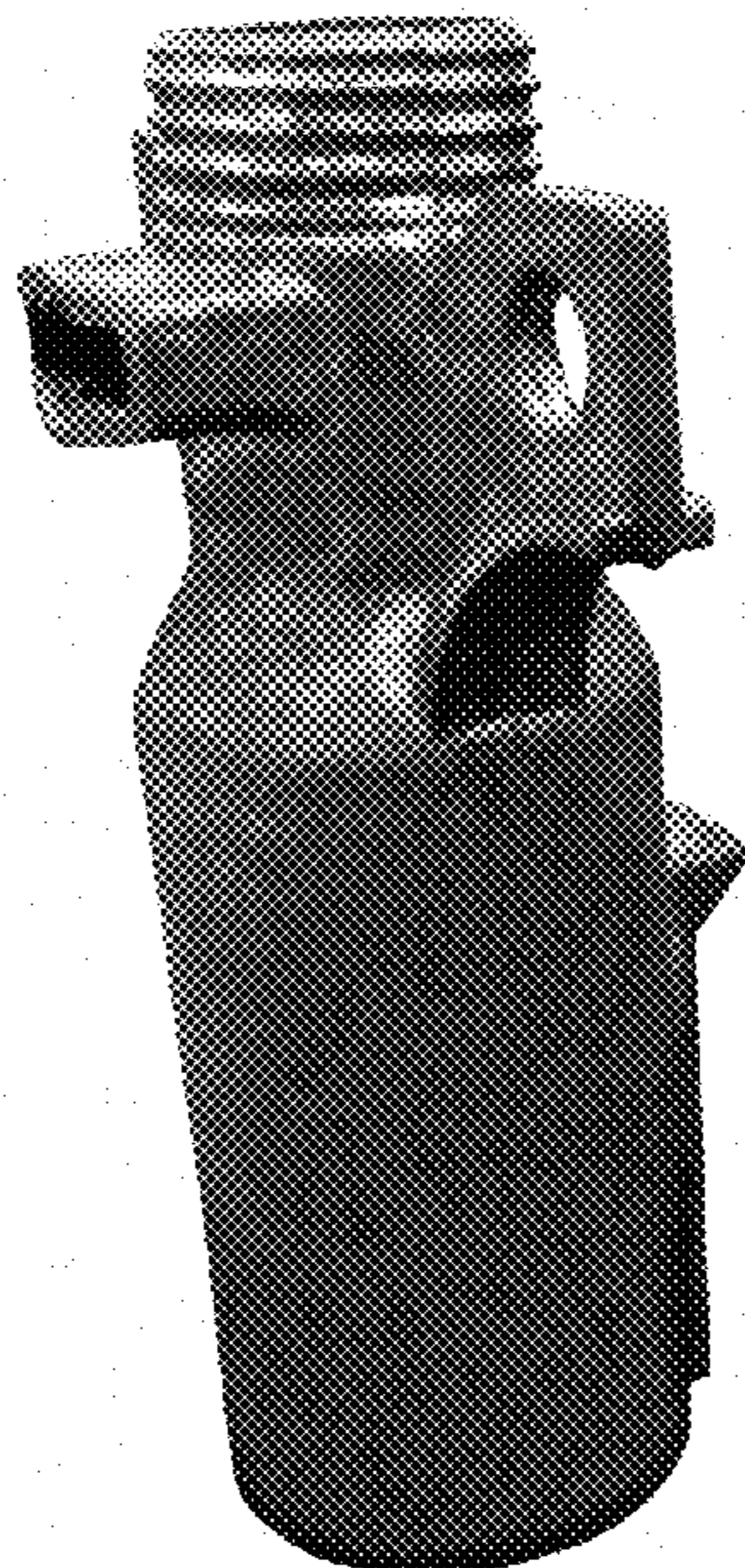



Fig. 1

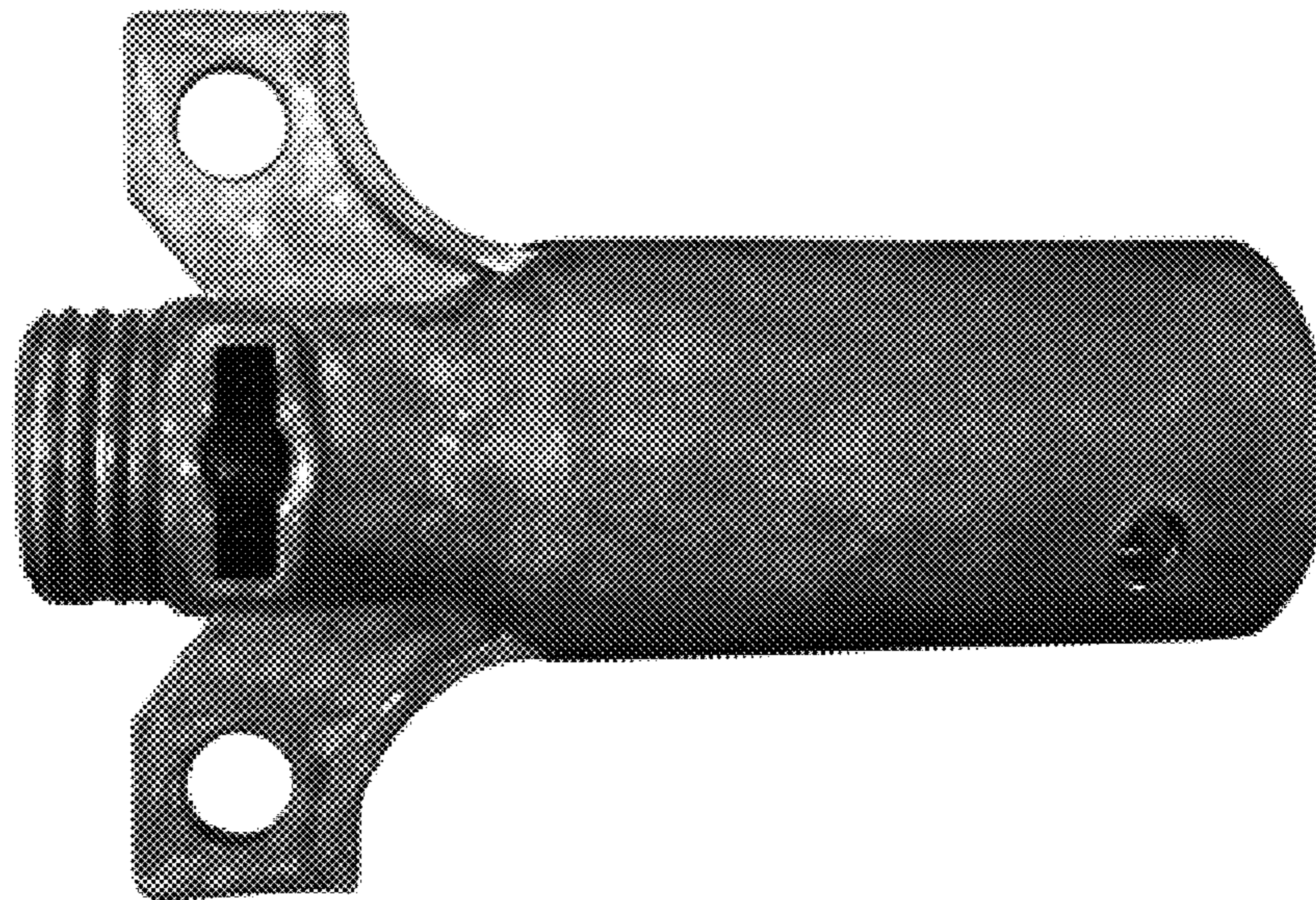

Fig. 2

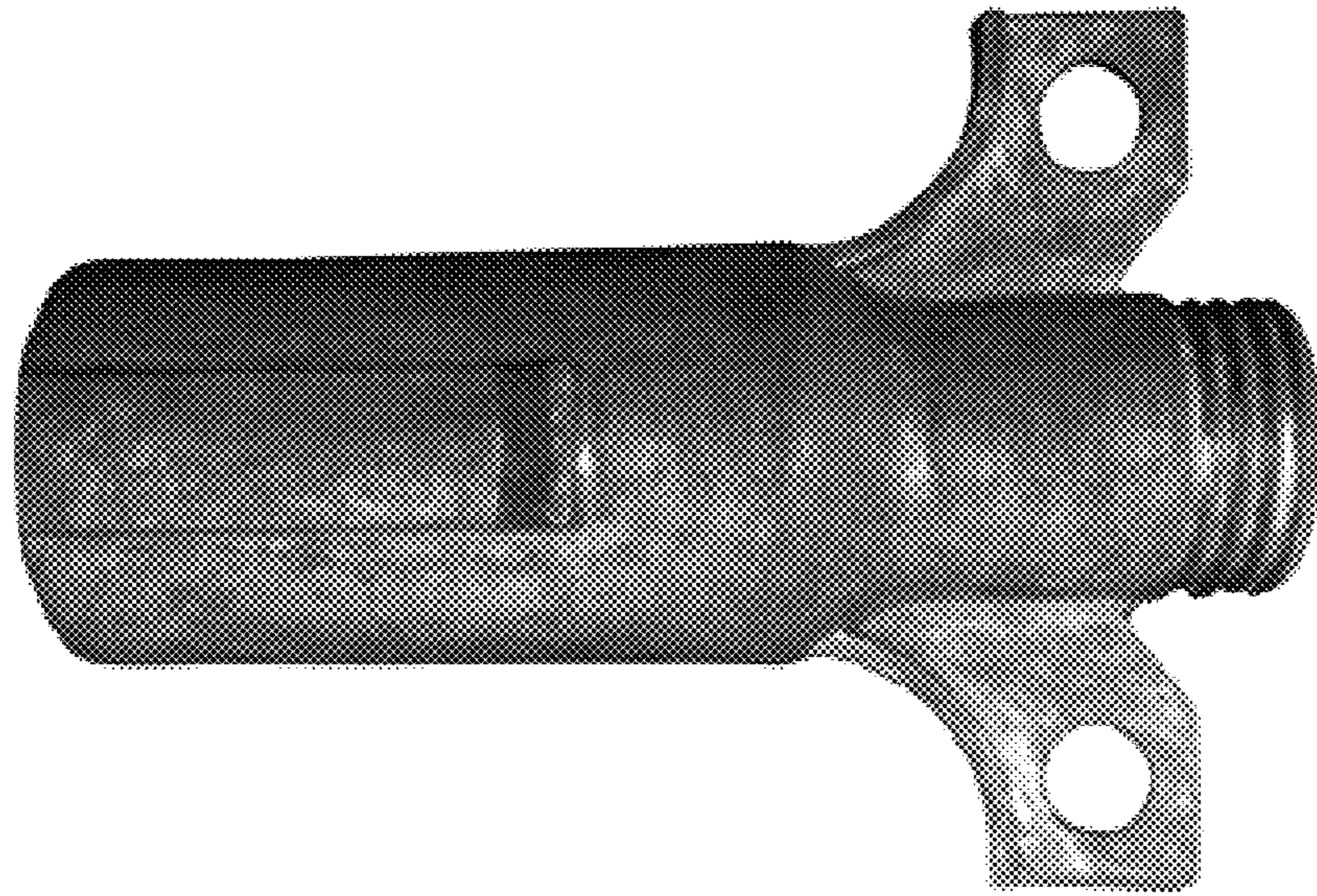

Fig. 3

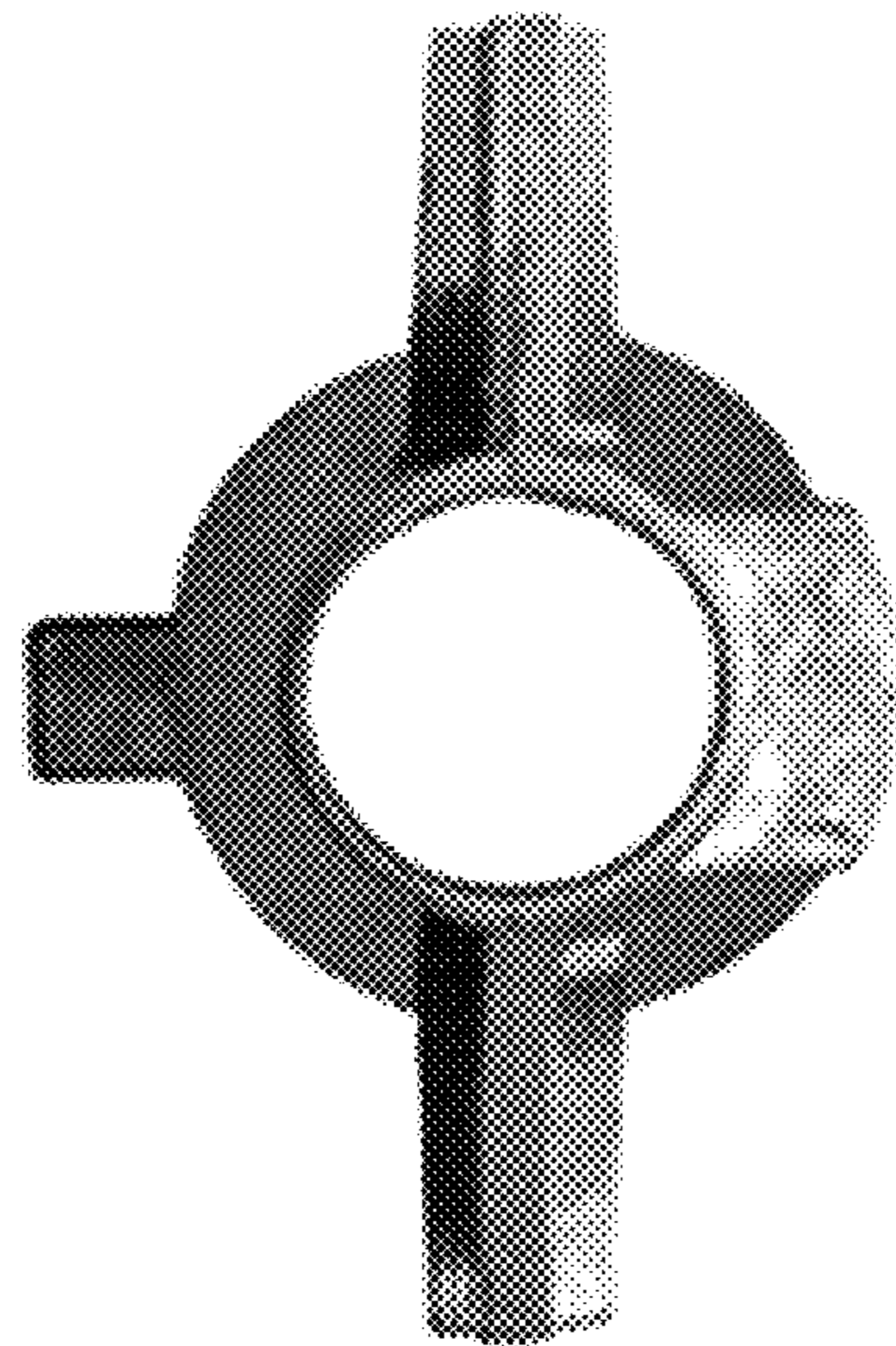

Fig. 4

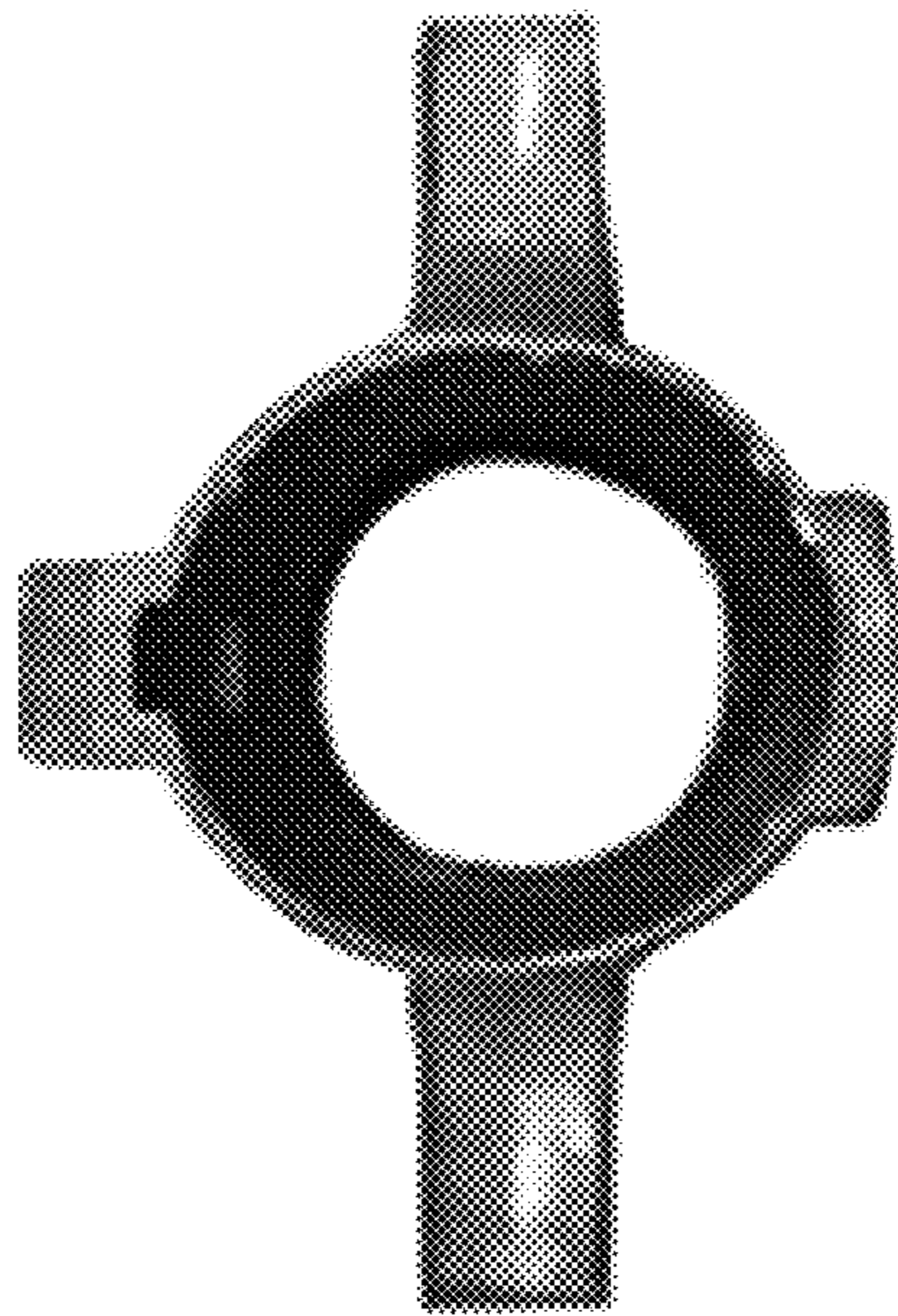

Fig. 5

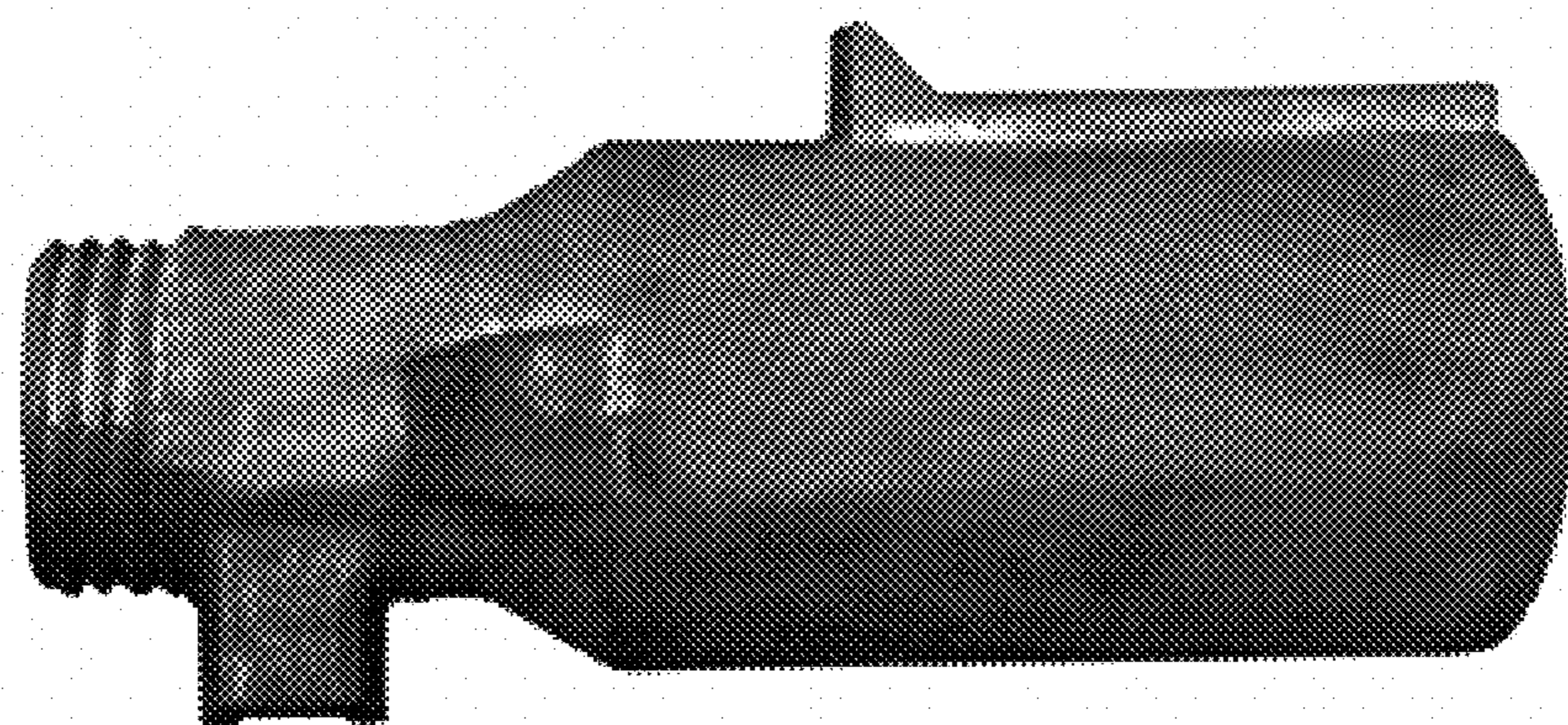

Fig. 6

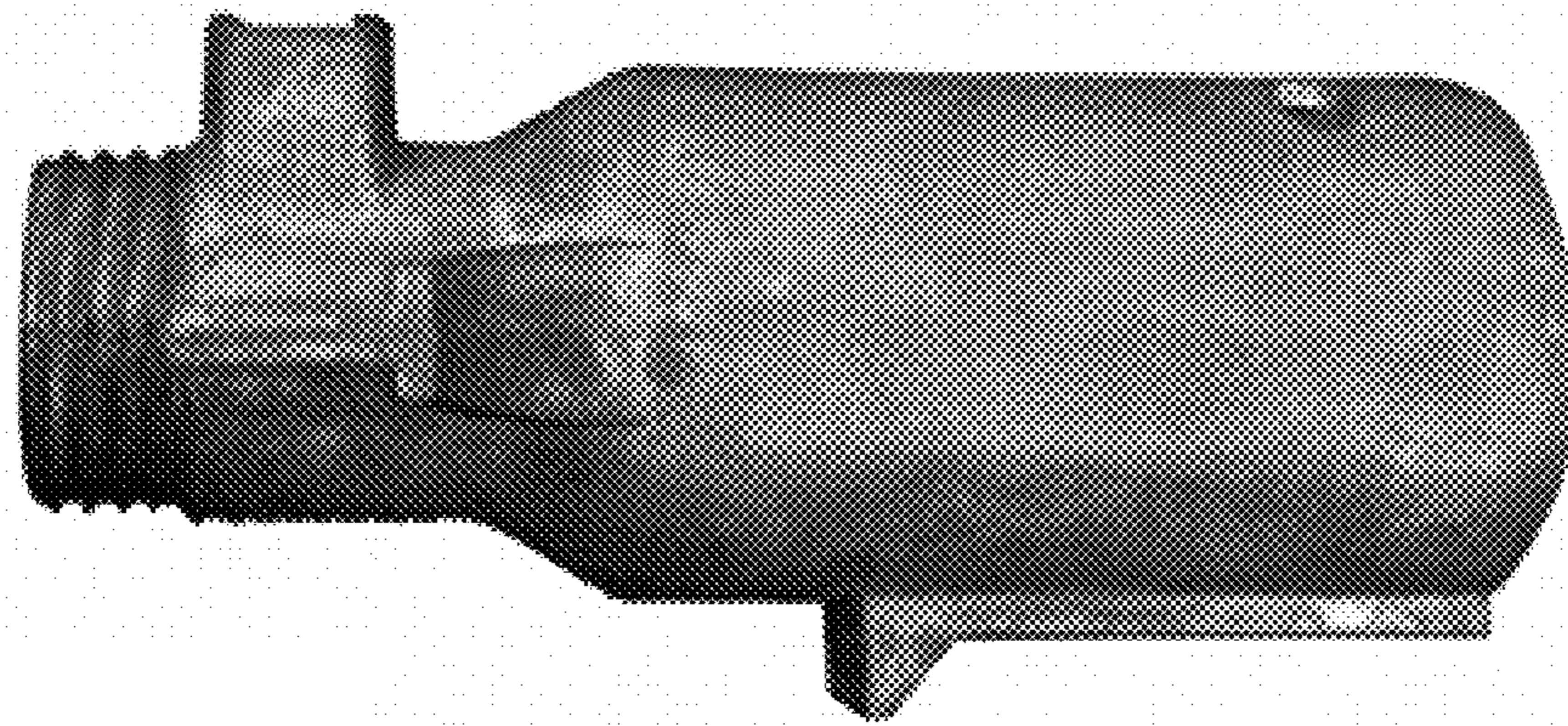

Fig. 7