



US00D749989S

(12) **United States Design Patent**
Schanz et al.

(10) **Patent No.:** **US D749,989 S**

(45) **Date of Patent:** **** Feb. 23, 2016**

(54) **PAIR OF MOTORCYCLE CRASH BARS**

- (71) Applicant: **Touratech AG**, Niedereschach (DE)
- (72) Inventors: **Jochen Schanz**, Niedereschach (DE);
Herbert Schwarz, Niedereschach (DE)
- (73) Assignee: **Touratech AG** (DE)
- (**) Term: **14 Years**
- (21) Appl. No.: **29/509,660**
- (22) Filed: **Nov. 20, 2014**

(30) **Foreign Application Priority Data**

May 23, 2014 (EP) 001412316-0001

(51) **LOC (10) Cl.** **12-11**

(52) **U.S. Cl.**
USPC **D12/126; D12/114**

(58) **Field of Classification Search**
USPC D12/110, 114, 126; D8/300, 303;
D15/5; 180/90.6, 160.1, 219, 284,
180/288.4, 291, 304.3, 304.4, 770, 755,
180/756, 784; 293/105, 116, 142
CPC B62J 23/00; B62J 25/00
See application file for complete search history.

(56) **References Cited**

U.S. PATENT DOCUMENTS

- D270,527 S * 9/1983 O'Rourke D12/114
- D361,311 S * 8/1995 Lindby D12/114
- 6,419,039 B1 * 7/2002 Wagner B62J 27/00
180/219
- D484,074 S * 12/2003 Henneberry D12/114
- 6,910,704 B1 * 6/2005 Celiceo B62J 27/00
280/304.4
- D513,719 S * 1/2006 Egan D12/126
- D521,416 S * 5/2006 Lindby D12/114
- 7,108,273 B2 * 9/2006 Hunwardsen B62J 25/00
180/219
- D546,734 S * 7/2007 Wang D12/126
- D548,142 S * 8/2007 Lindby D12/114

(Continued)

OTHER PUBLICATIONS

Touratech USA. "Crash Bars BMW R1200GS—Touratech"—
YouTube.com., Jun. 14, 2012 [online], [retrieved on Oct. 8, 2015].
Retrieved from the Internet <URL: <https://www.youtube.com/watch?v=z3oVzFJs4i4>>.*

(Continued)

Primary Examiner — Philip S Hyder

Assistant Examiner — Darlington Ly

(74) *Attorney, Agent, or Firm* — Tarolli, Sundheim, Covell
& Tummino LLP

(57) **CLAIM**

We claim the ornamental design for a pair of motorcycle crash
bars, as shown and described.

DESCRIPTION

FIG. 1 is a perspective view of the right hand crash bar of the
pair of motorcycle crash bars;
FIG. 2 is a front elevation view thereof;
FIG. 3 is a rear elevation view thereof;
FIG. 4 is a left side elevation view thereof;
FIG. 5 is a right side elevation view thereof;
FIG. 6 is a top plan view thereof; and
FIG. 7 is a bottom plan view thereof;
FIG. 8 is a perspective view of the left hand crash bar of the
pair of motorcycle crash bars;
FIG. 9 is a front elevation view thereof;
FIG. 10 is a rear elevation view thereof;
FIG. 11 is a left side elevation view thereof;
FIG. 12 is a right side elevation view thereof;
FIG. 13 is a top plan view thereof; and
FIG. 14 is a bottom plan view thereof; and,
FIG. 15 is a perspective view of the pair of motorcycle crash
bars in which the right hand and left hand crash bars are
interconnected by a connector piece.
The broken line showing of the connector piece is for the
purpose of illustrating environmental structure and forms no
part of the claimed design.

1 Claim, 9 Drawing Sheets

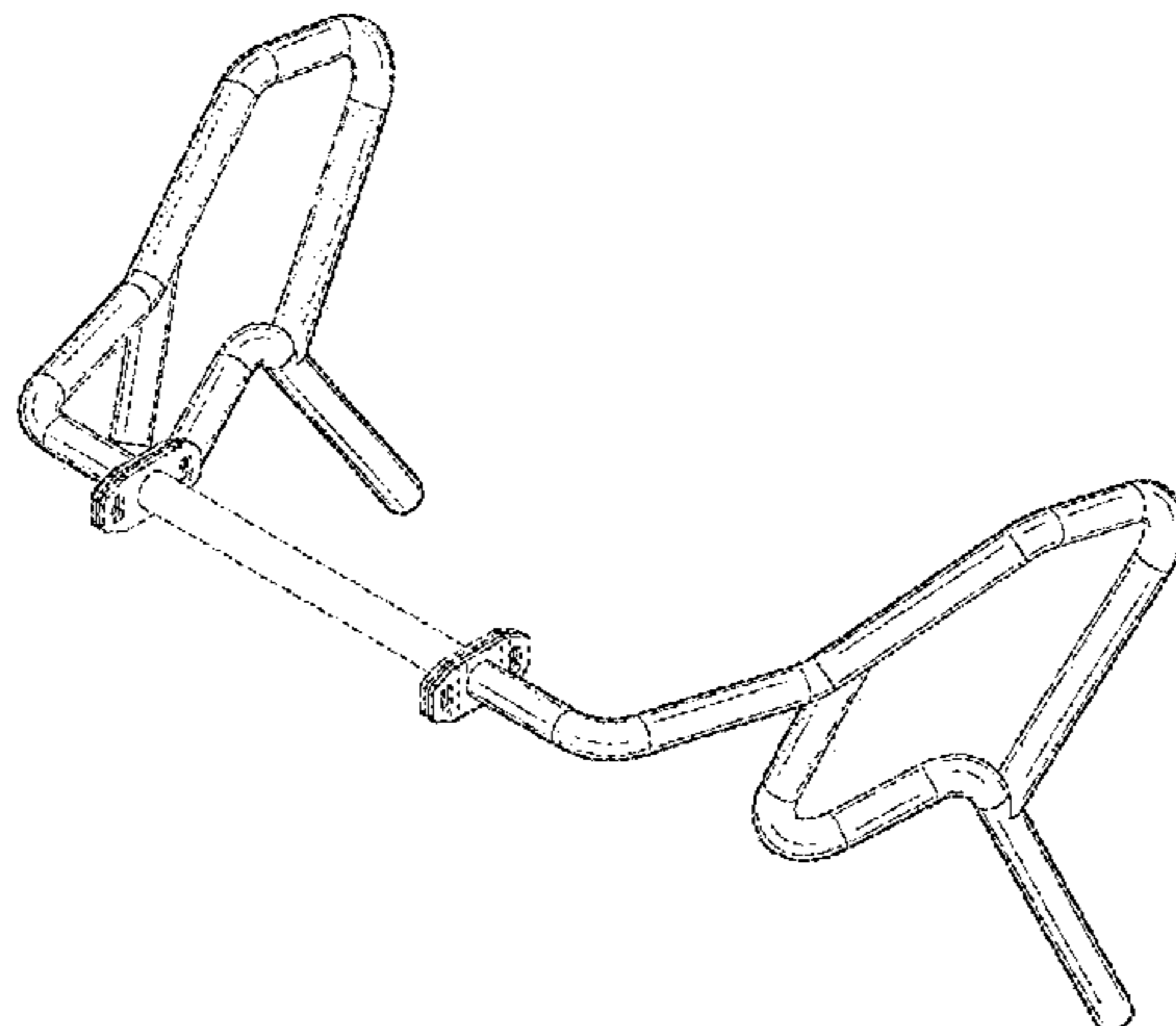

(56)

References Cited

U.S. PATENT DOCUMENTS

7,475,897 B2 * 1/2009 Wang B62J 23/00
180/219
D730,266 S * 5/2015 Schanz D12/407
2005/0178595 A1 * 8/2005 Lindby B62J 25/00
180/219

OTHER PUBLICATIONS

AltRider. "AltRider Crash Bars for the BMW F 800 GS—Install"—
YouTube.com., Sep. 13, 2010 [online], [retrieved on Oct. 8, 2015].
Retrieved from the Internet <URL: [https://www.youtube.com/
watch?v=zxSByKZ0ids](https://www.youtube.com/watch?v=zxSByKZ0ids)>.*

* cited by examiner

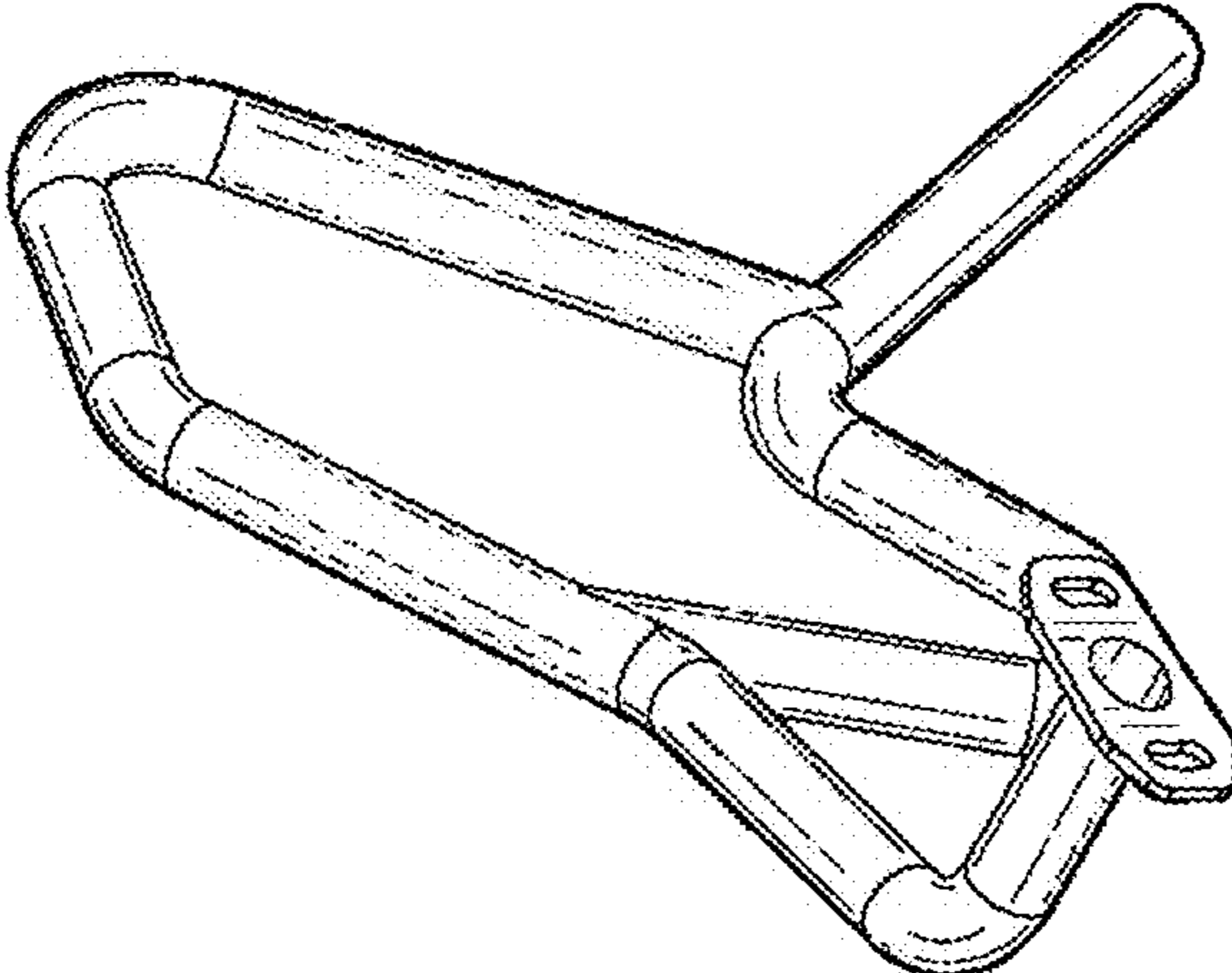

FIG. 1

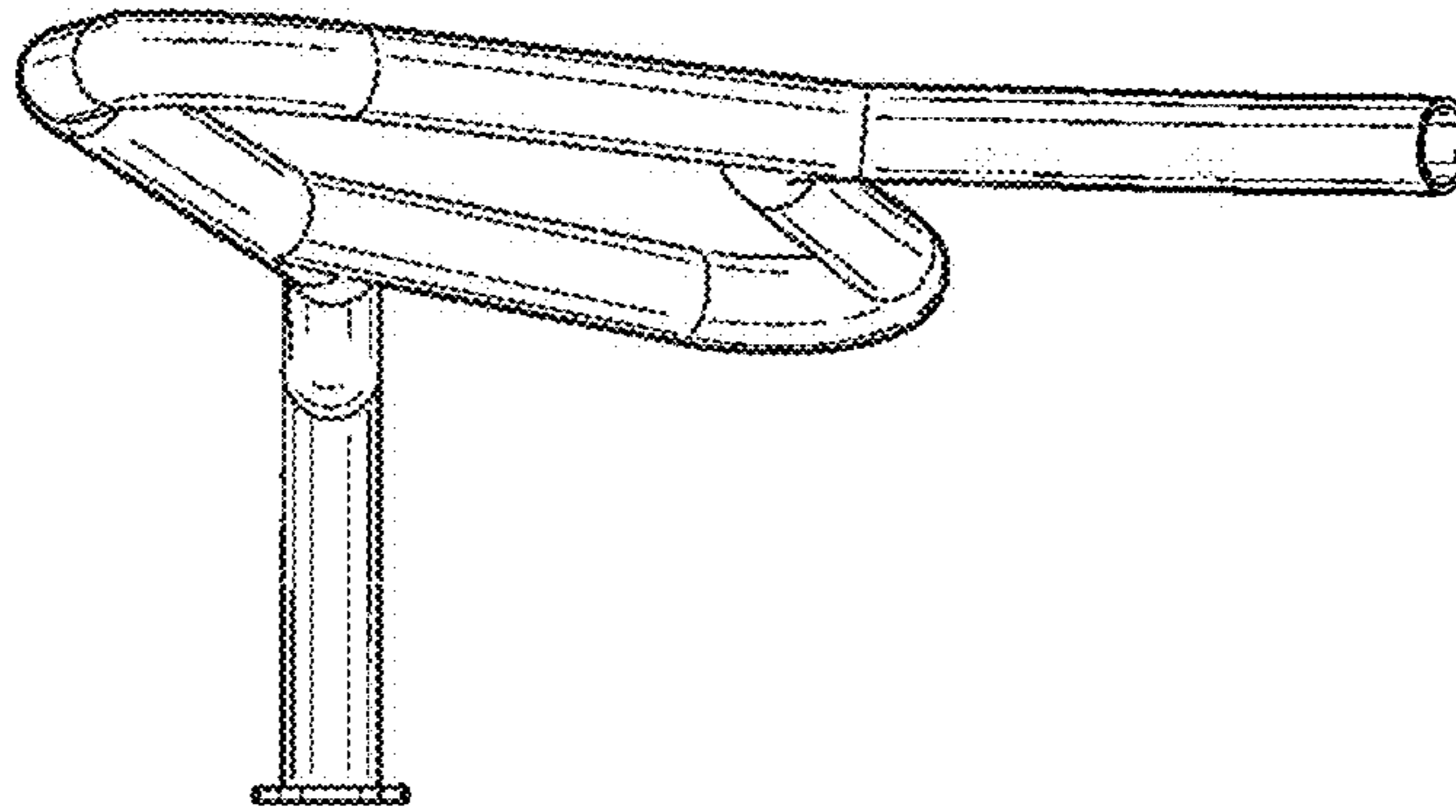

FIG. 3

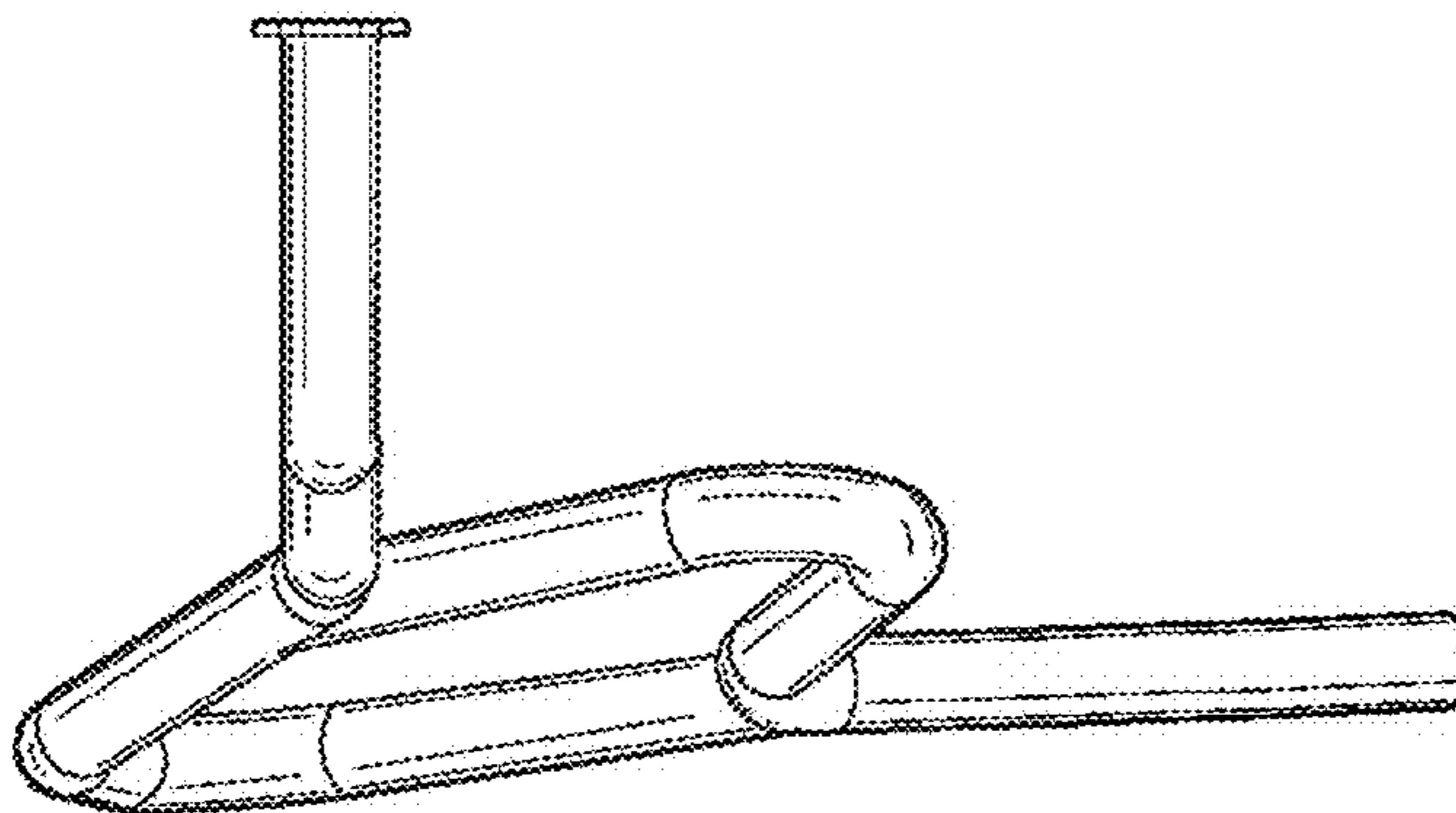

FIG. 2

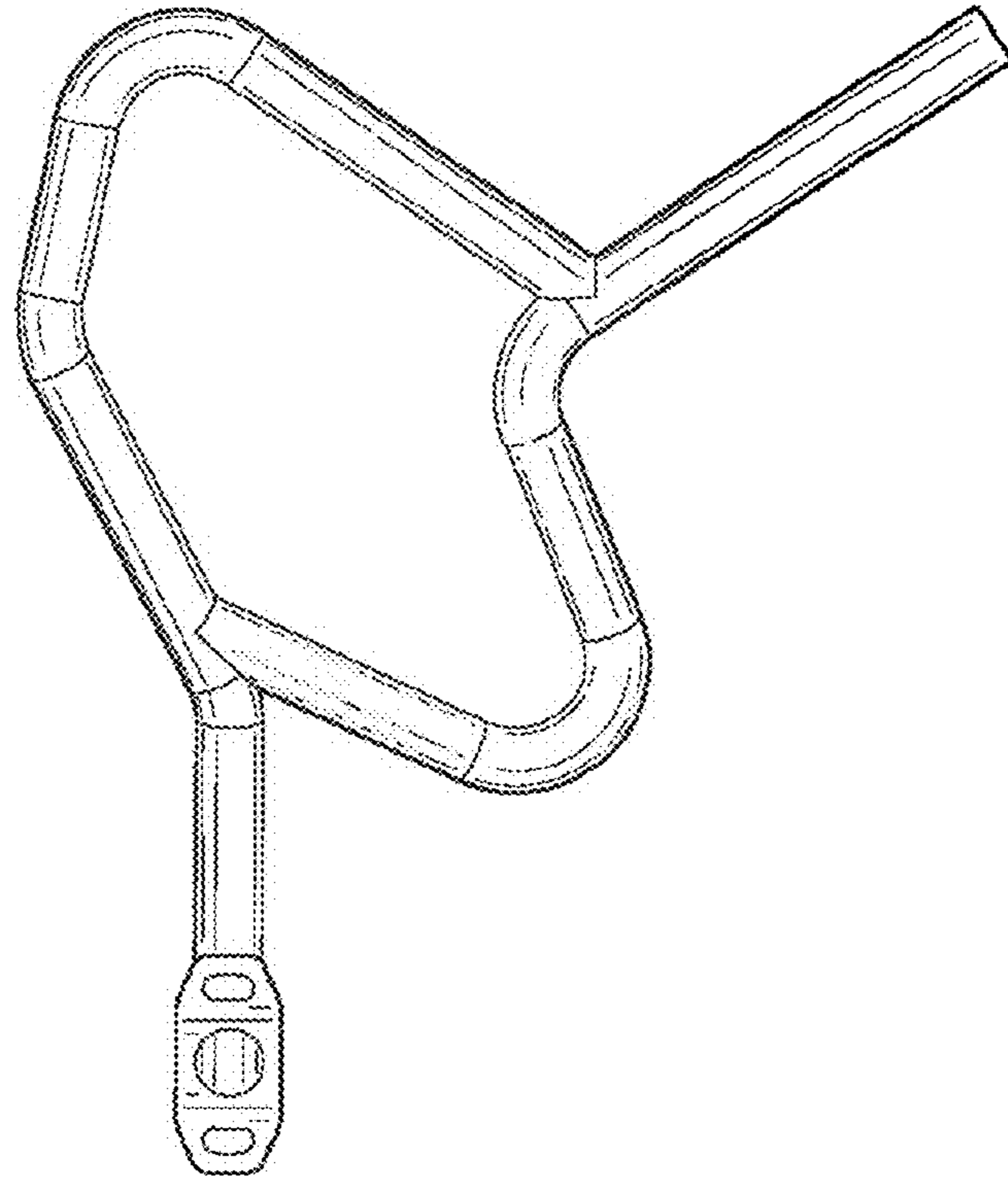

FIG. 4

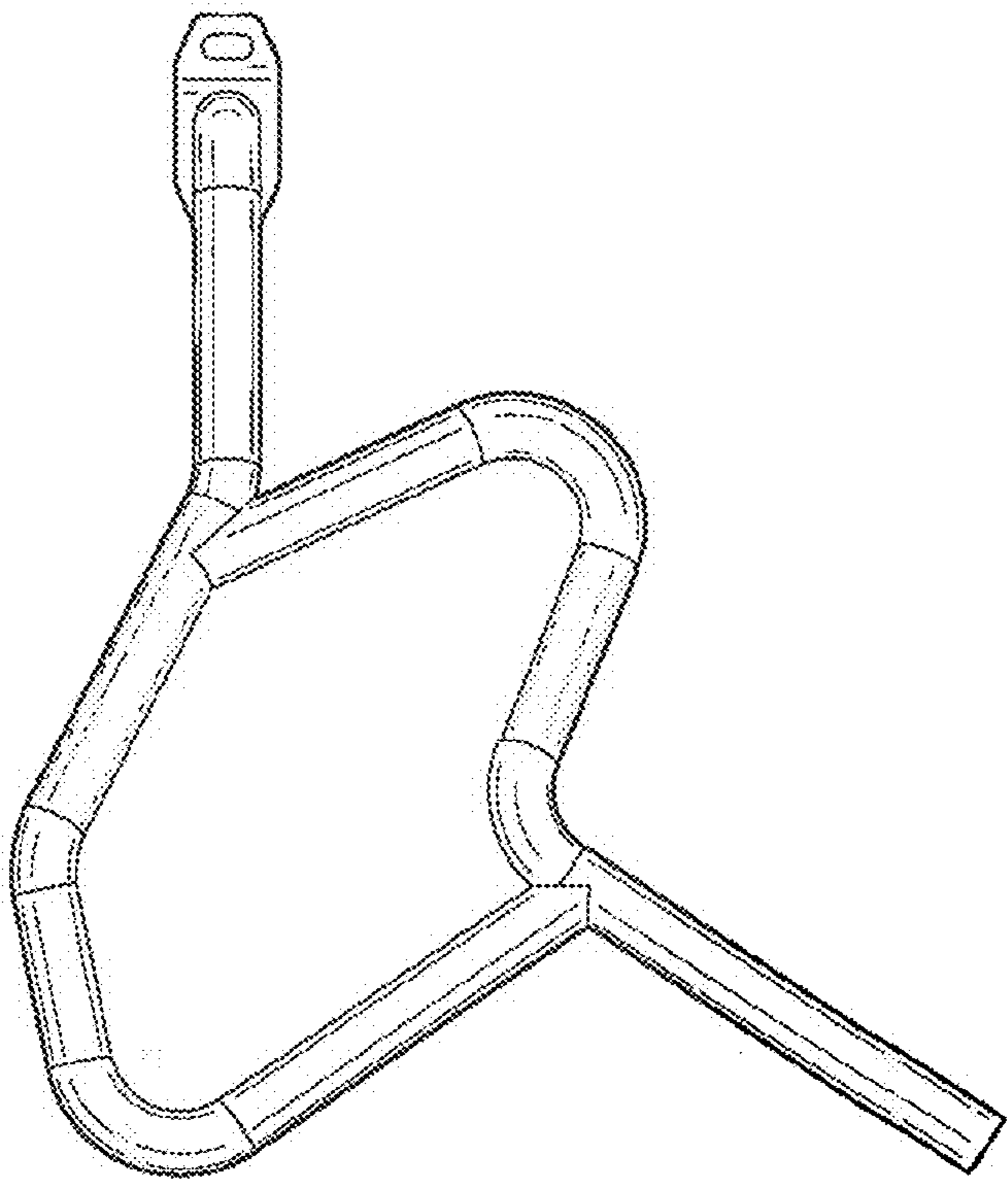

FIG. 5

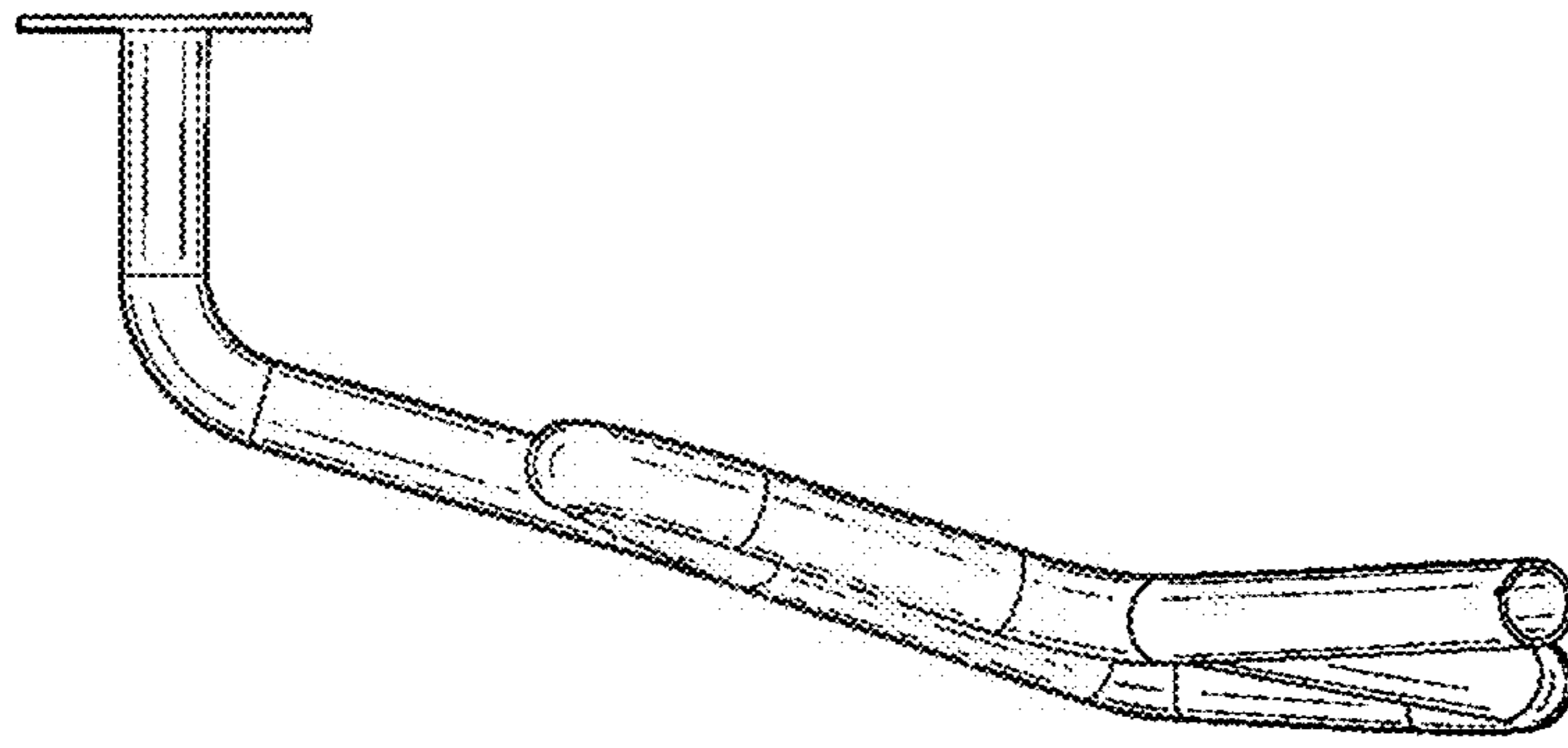

FIG. 7

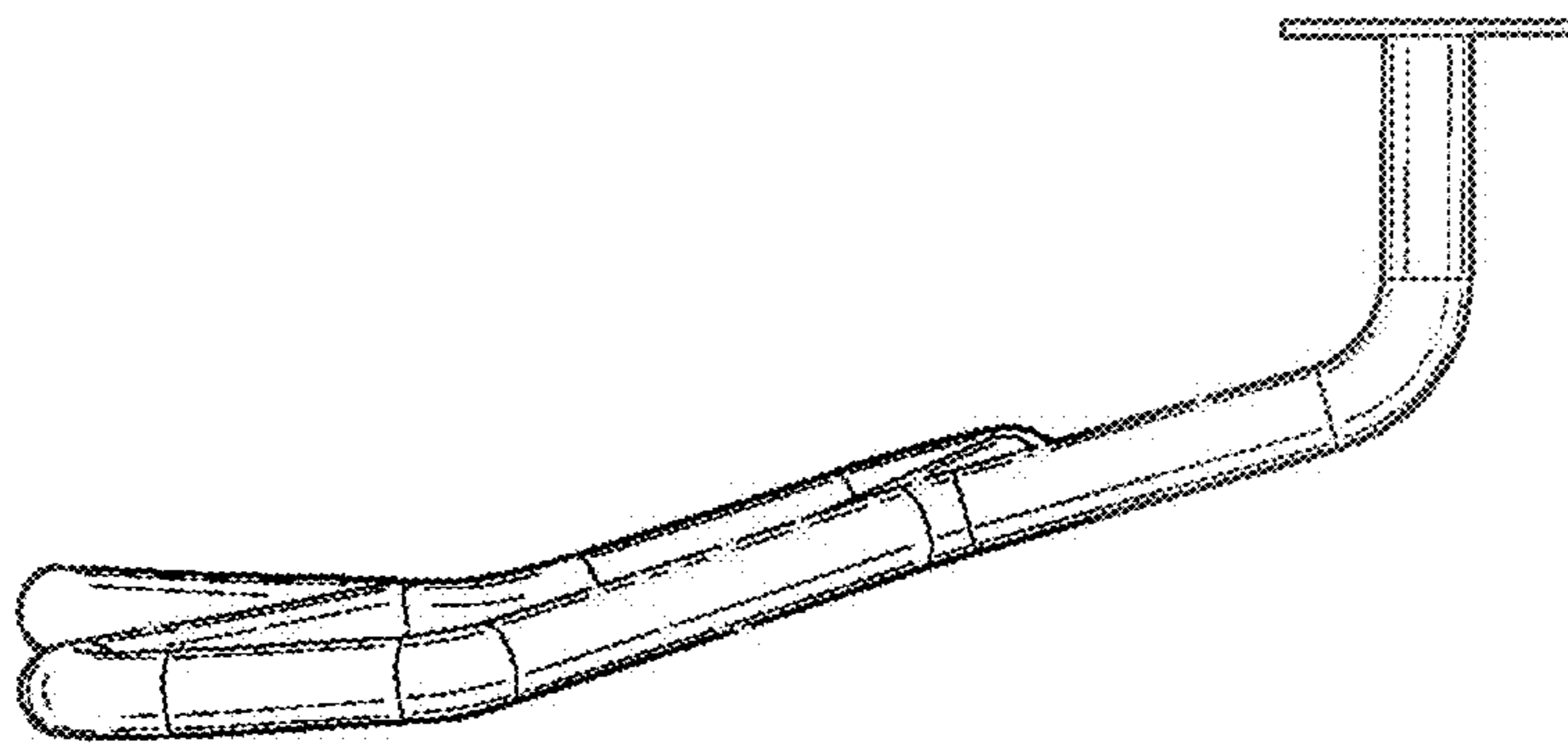

FIG. 6

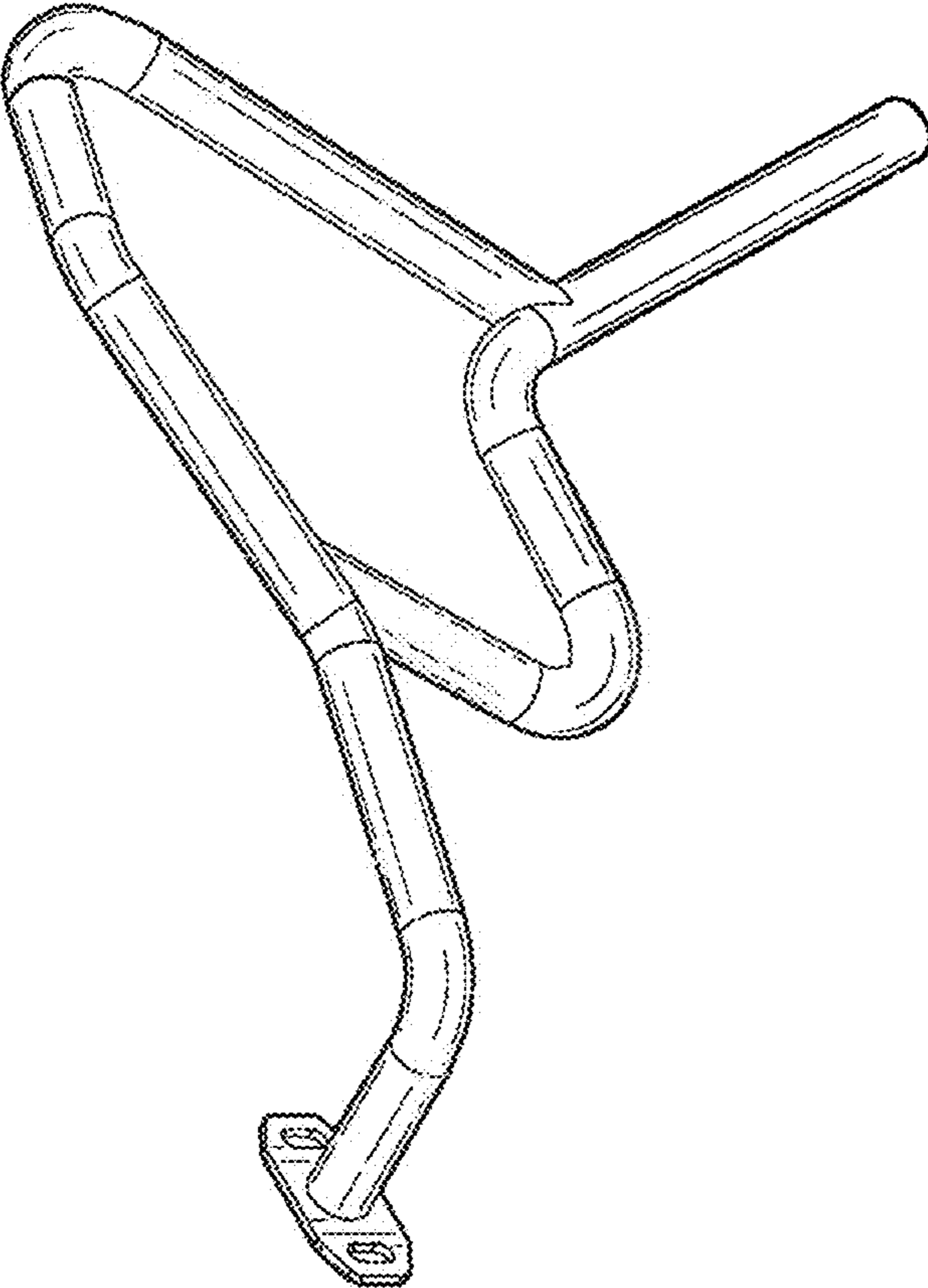

FIG. 8

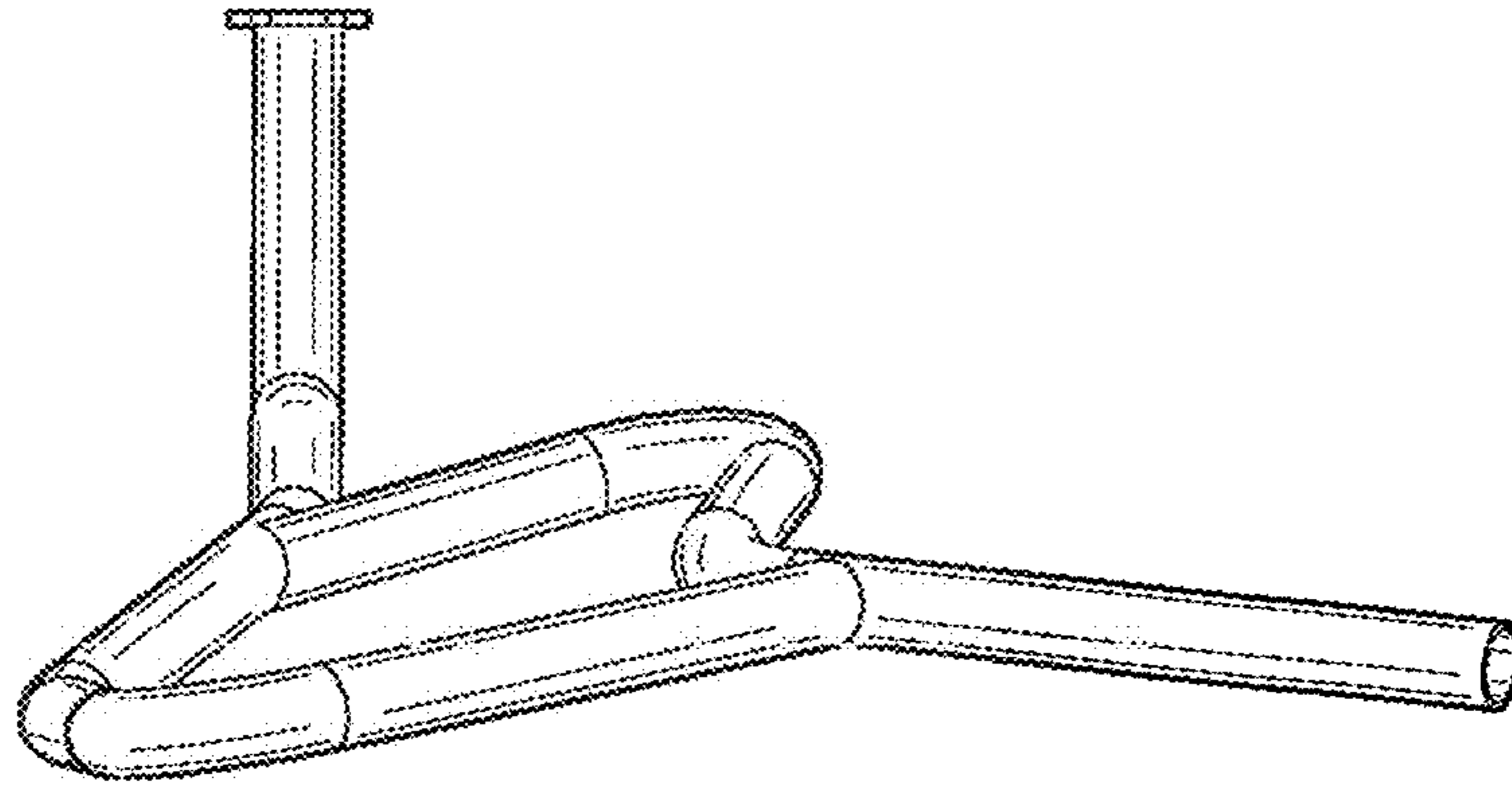

FIG. 10

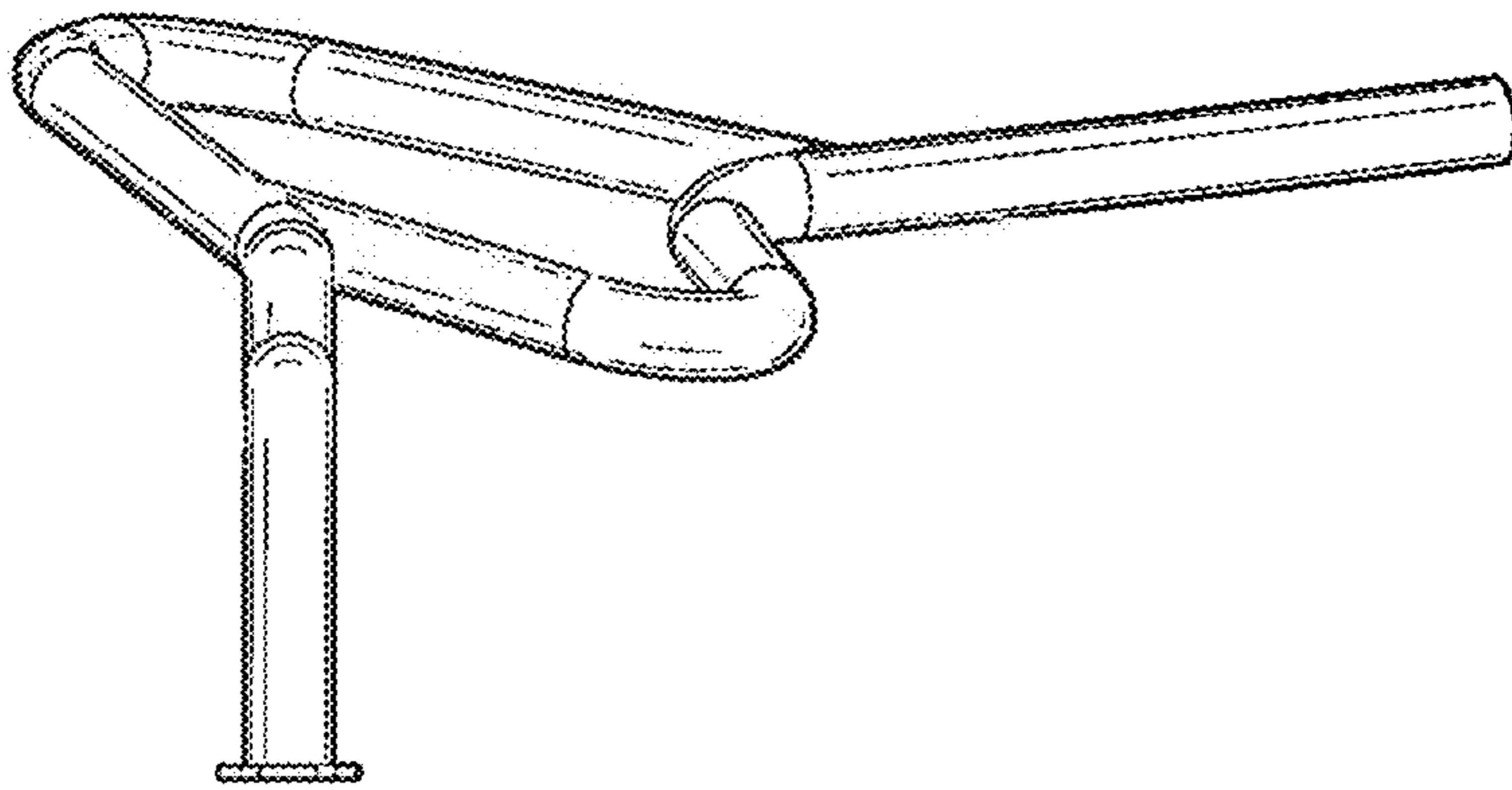

FIG. 9

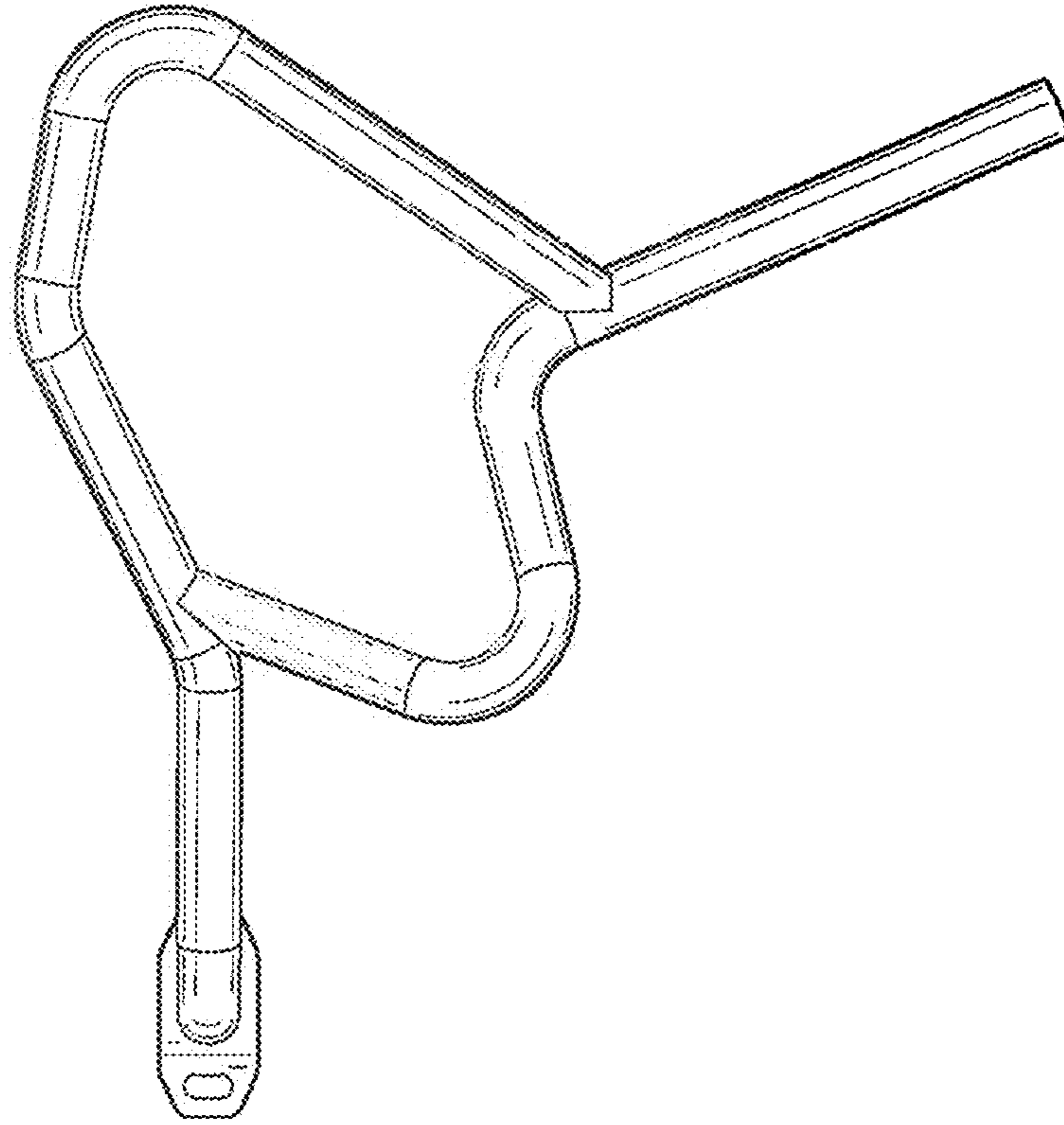

FIG. 11

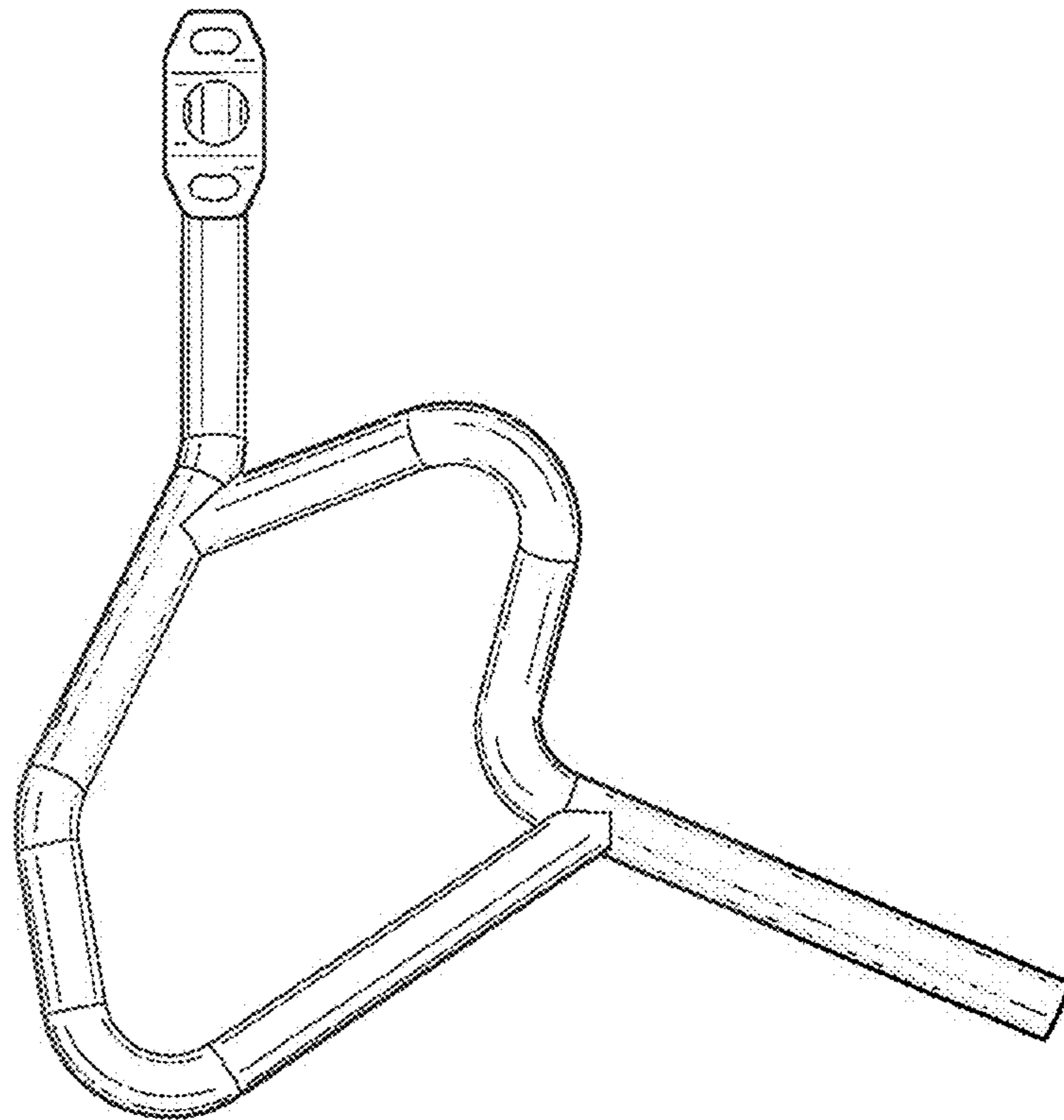

FIG. 12

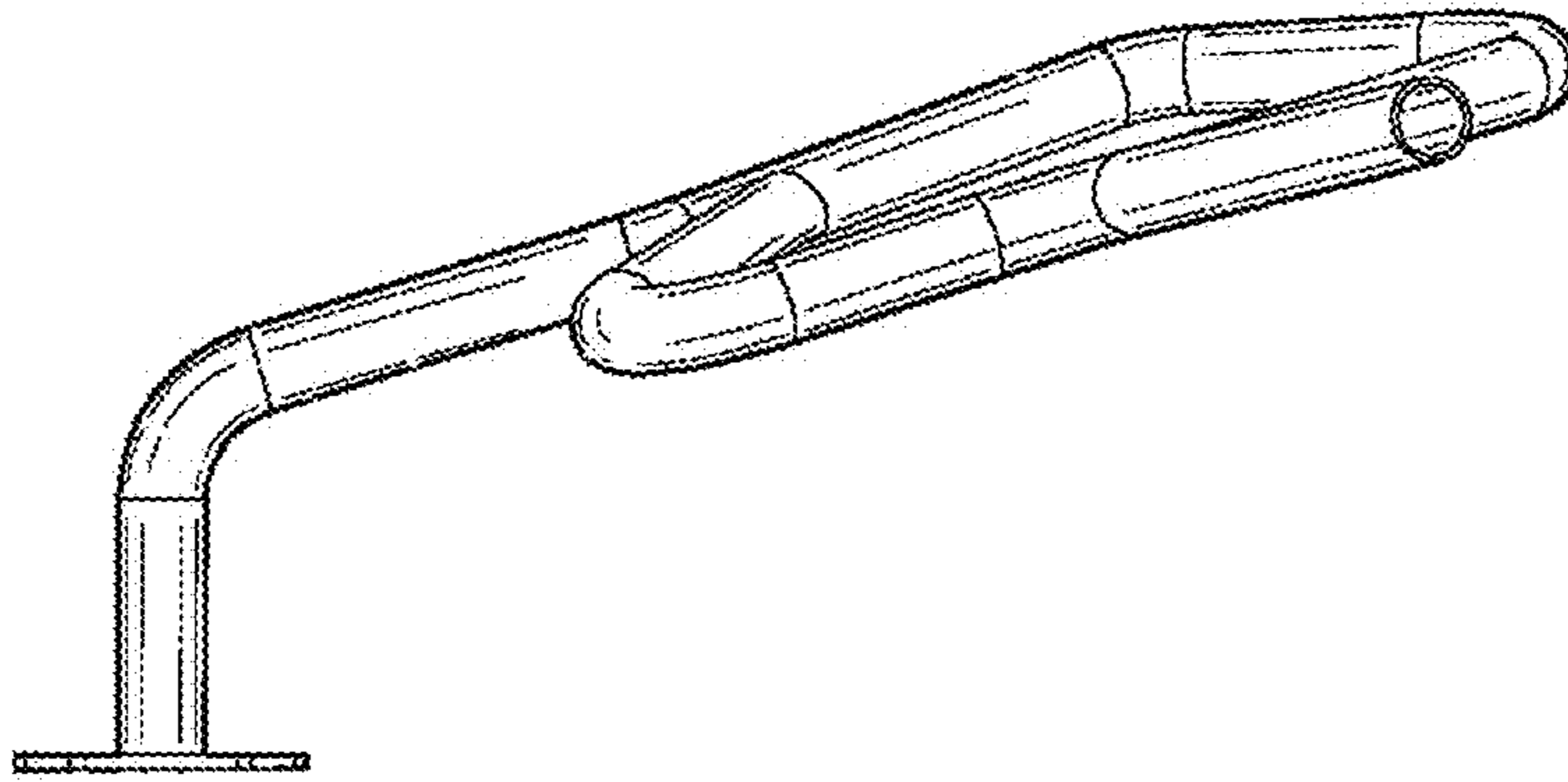

FIG. 14

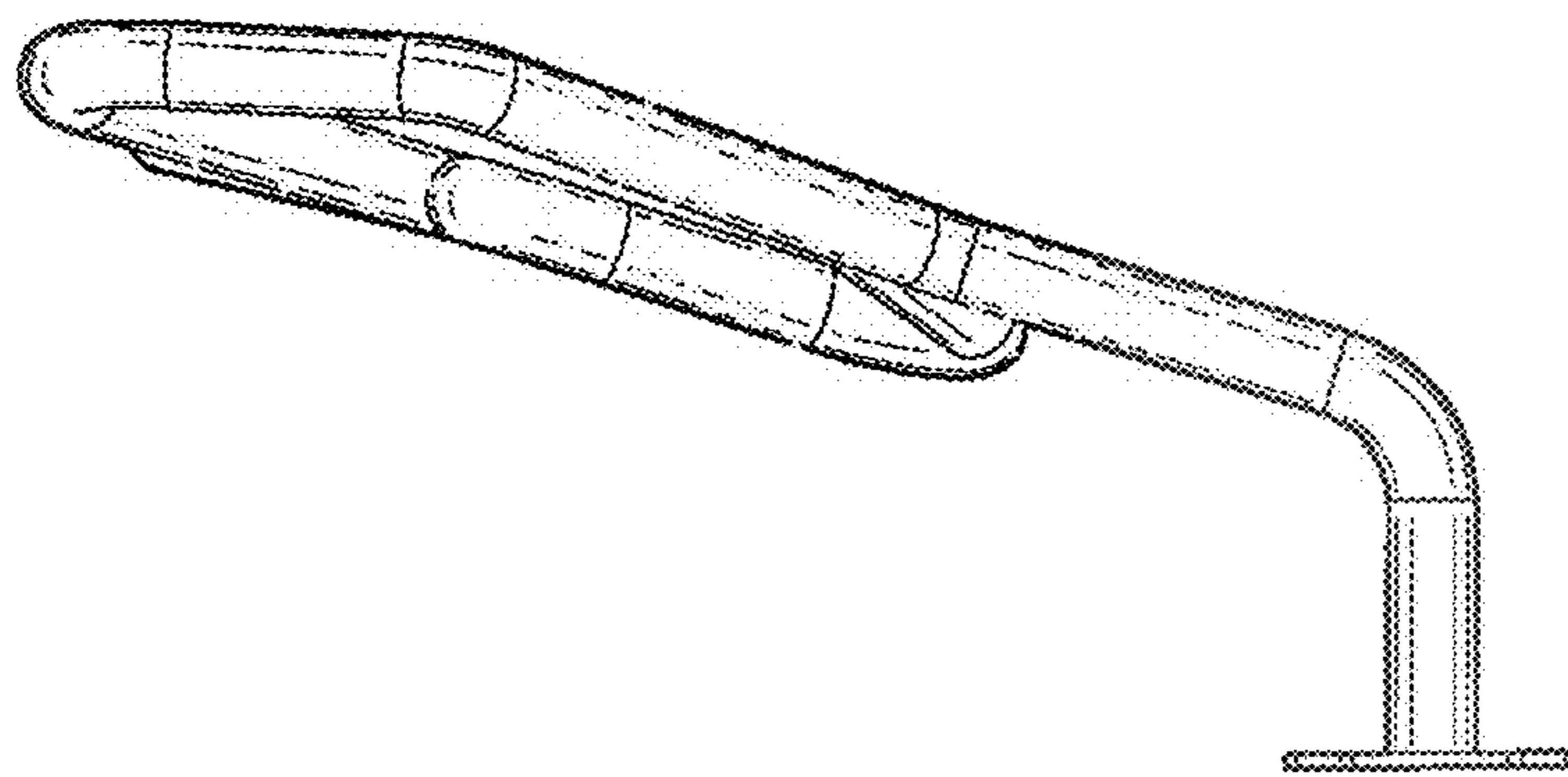

FIG. 13

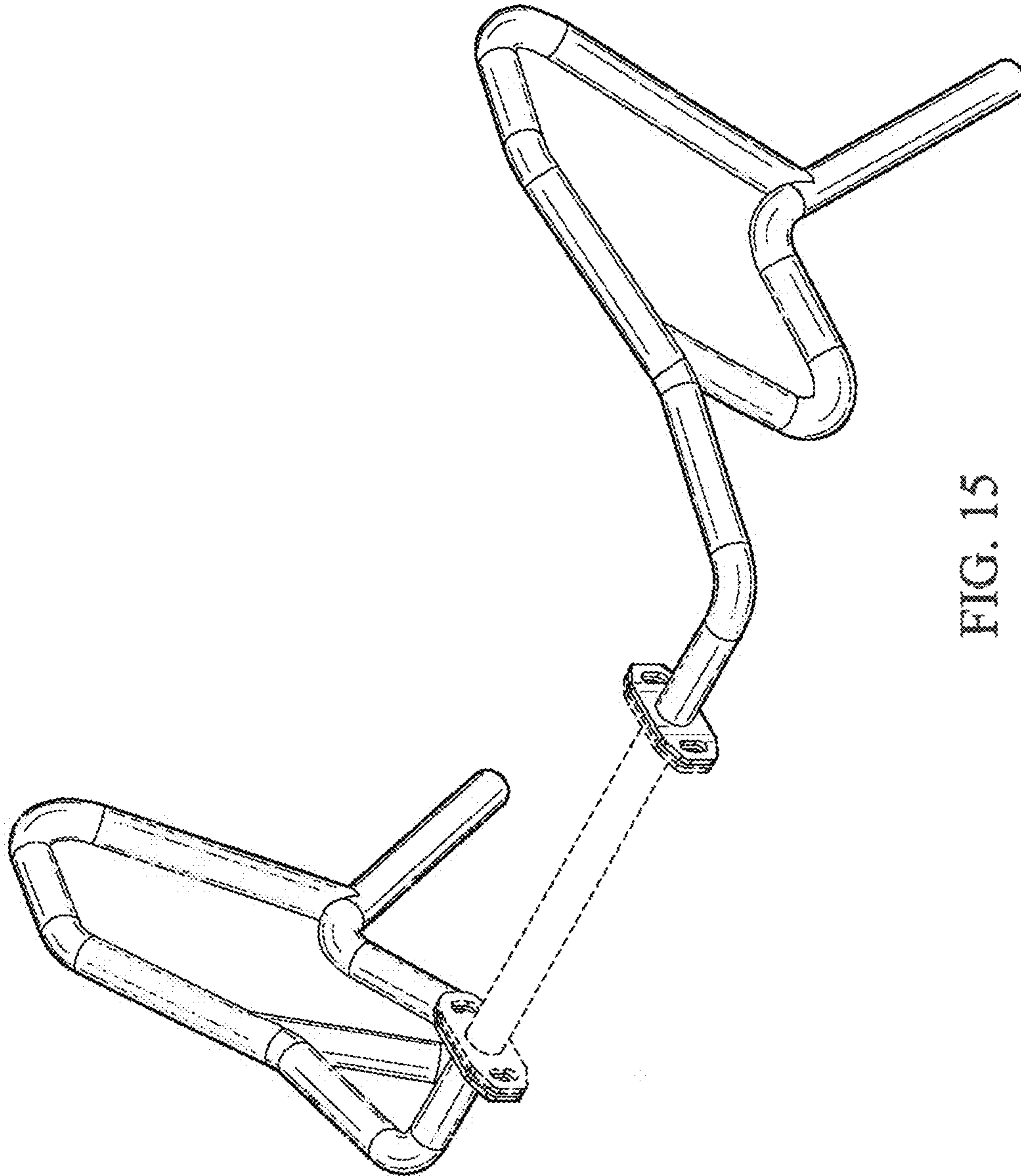

FIG. 15