



US00D749500S

(12) **United States Design Patent**
Merzig

(10) **Patent No.:** **US D749,500 S**

(45) **Date of Patent:** **** Feb. 16, 2016**

(54) **AERODYNAMIC TIRE VALVE CAP, TOY AND/OR REPLICA**

2002/0163792 A1* 11/2002 Formoso F21K 2/06
362/34

* cited by examiner

(71) Applicant: **Matthew Merzig**, Ashburn, VA (US)

Primary Examiner — George D Kirschbaum

(72) Inventor: **Matthew Merzig**, Ashburn, VA (US)

(57) **CLAIM**
The ornamental design for an aerodynamic tire valve cap, toy, and/or replica, as shown and described.

(73) Assignee: **Matthew Merzig**, Ashburn, VA (US)

DESCRIPTION

(**) Term: **14 Years**

(21) Appl. No.: **29/467,631**

(22) Filed: **Sep. 20, 2013**

(51) **LOC (10) Cl.** **12-15**

(52) **U.S. Cl.**
USPC **D12/607**

(58) **Field of Classification Search**
USPC D12/607; D14/5, 223, 206
See application file for complete search history.

FIG. 1 is a perspective view of an aerodynamic tire valve cap, toy and/or replica (the passenger side valve cap being a mirror image and is not shown) according to my novel design.
FIG. 2 is a top plan view thereof;
FIG. 3 is a bottom plan view thereof;
FIG. 4 is a front elevation view thereof;
FIG. 5 is a rear elevation view thereof;
FIG. 6 is an elevation view from the right side thereof; and
FIG. 7 is an elevation view from the left side thereof.
FIG. 8 is a cross-sectional view taken along section line 8-8 of FIG. 7.
FIG. 9 is a cross-sectional view taken along section line 9-9 of FIG. 7.
FIG. 10 is a cross-sectional view taken along section line 10-10 of FIG. 7.
FIG. 11 is a cross-sectional view taken along section line 11-11 of FIG. 7; and,
FIG. 12 is a cross-sectional view taken along section line 12-12 of FIG. 4.

(56) **References Cited**

U.S. PATENT DOCUMENTS

D712,821 S *	9/2014	Puppis	D12/607
D715,253 S *	10/2014	Lee	D14/205
D716,770 S *	11/2014	Bonahoom	D14/223
D721,351 S *	1/2015	Liu	D14/205
D728,533 S *	5/2015	Poulsen	D14/223
D730,877 S *	6/2015	Harper	D14/206

1 Claim, 8 Drawing Sheets

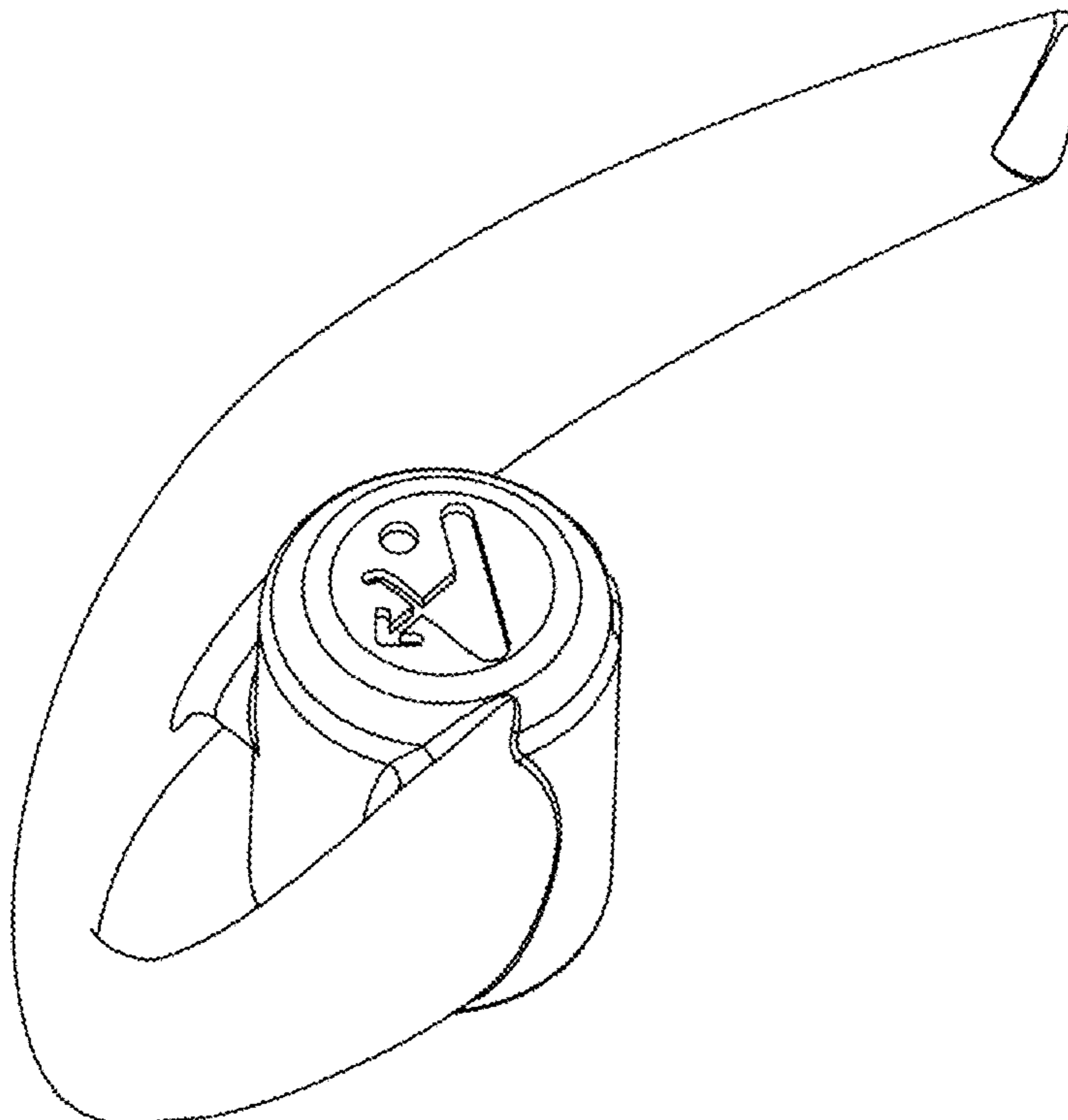

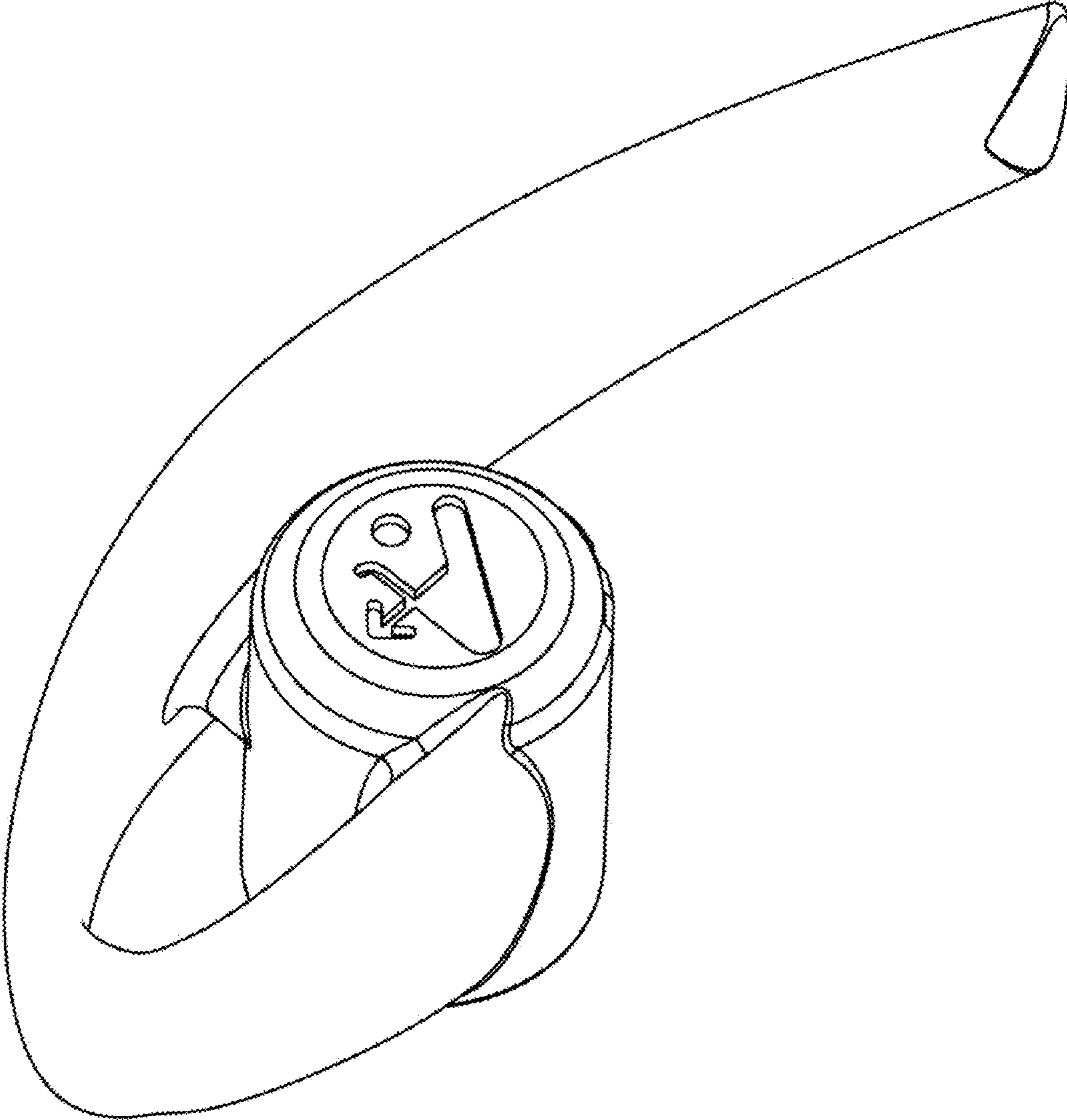

FIG. 1

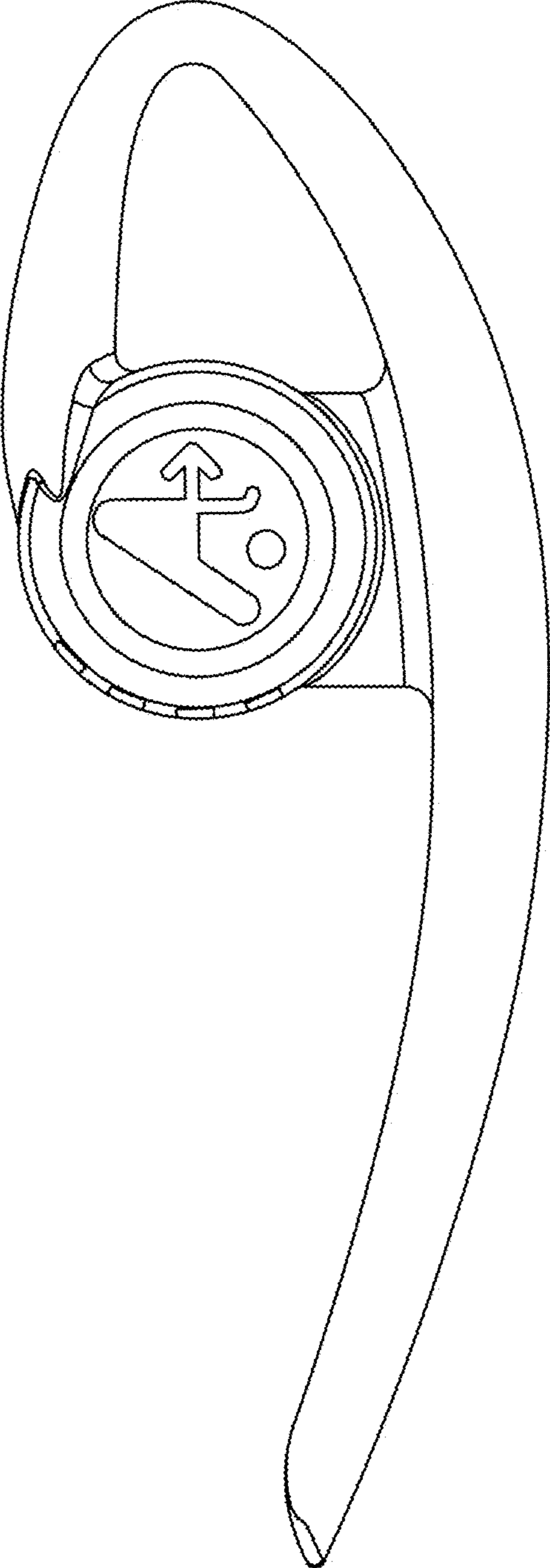

FIG. 2

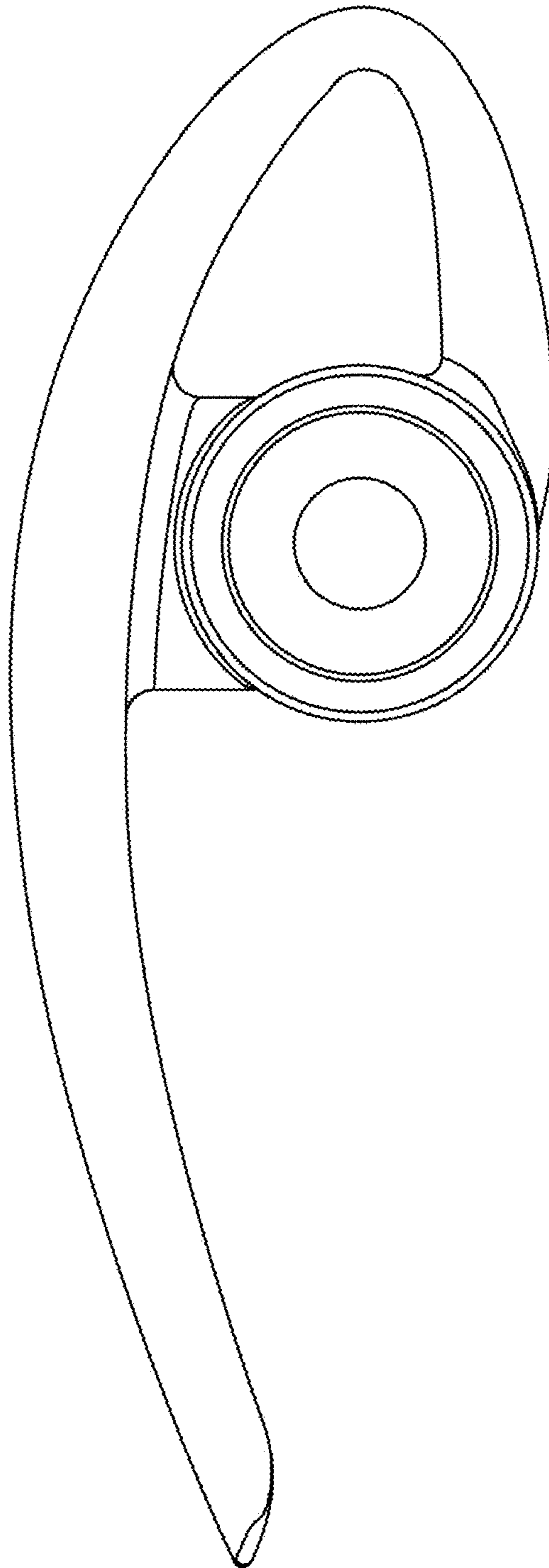

FIG. 3

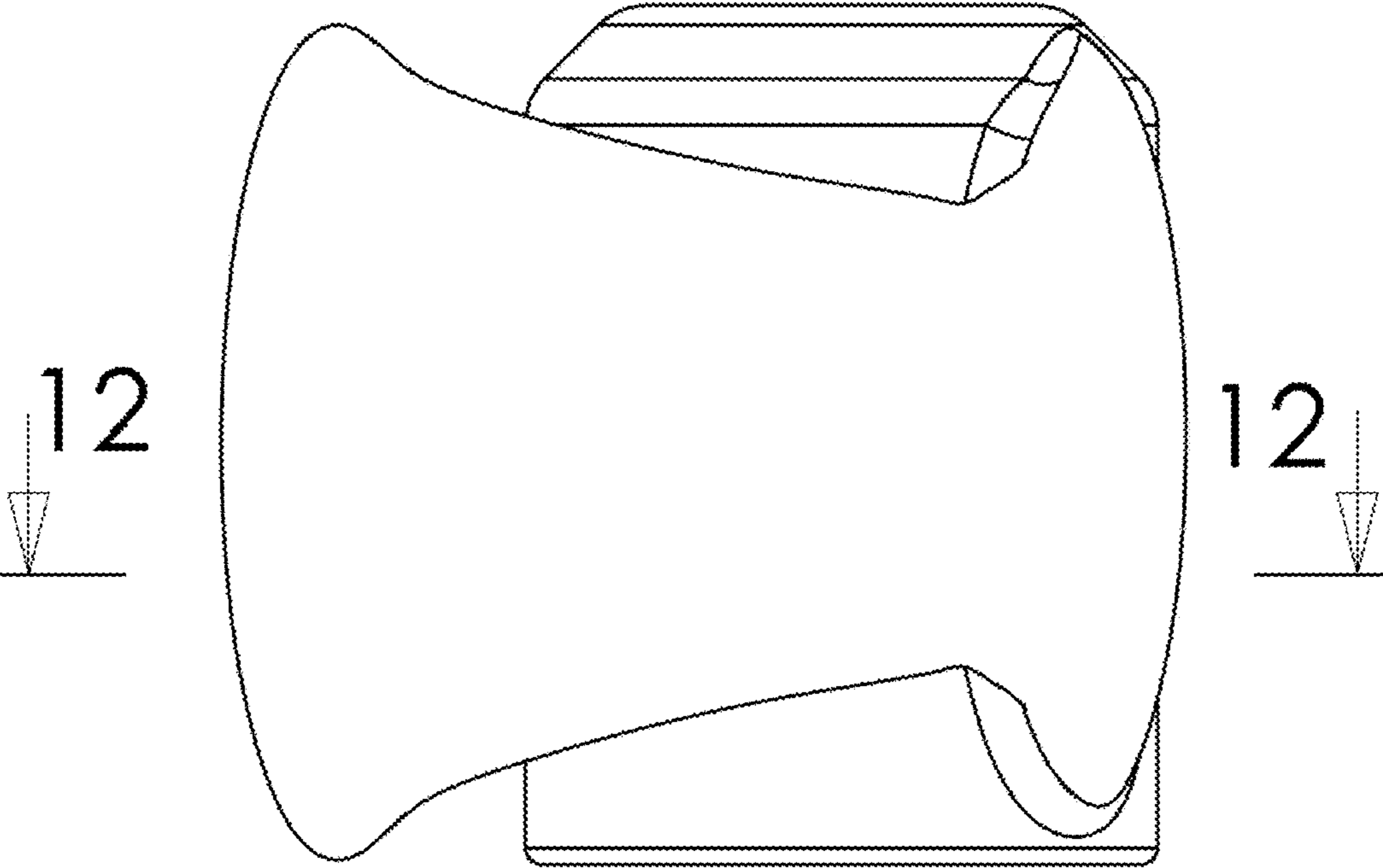

FIG. 4

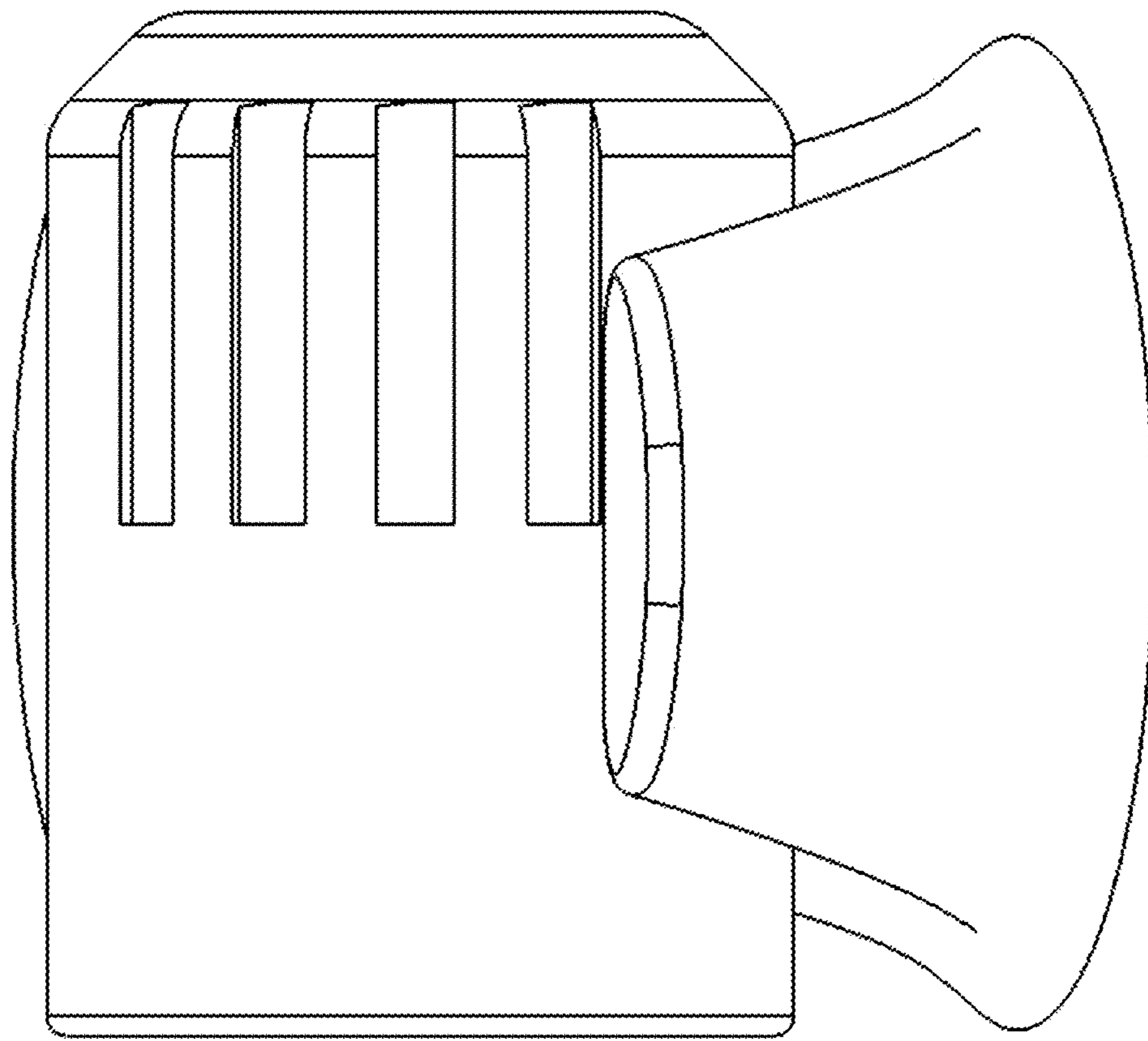

FIG. 5

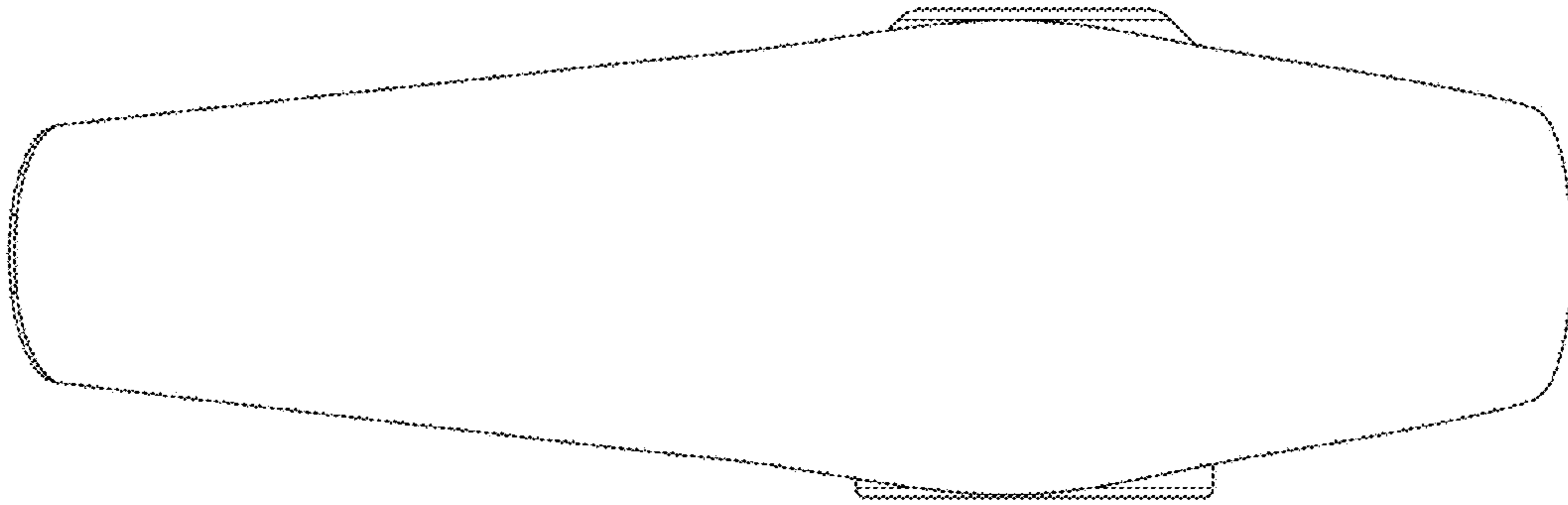

FIG. 6

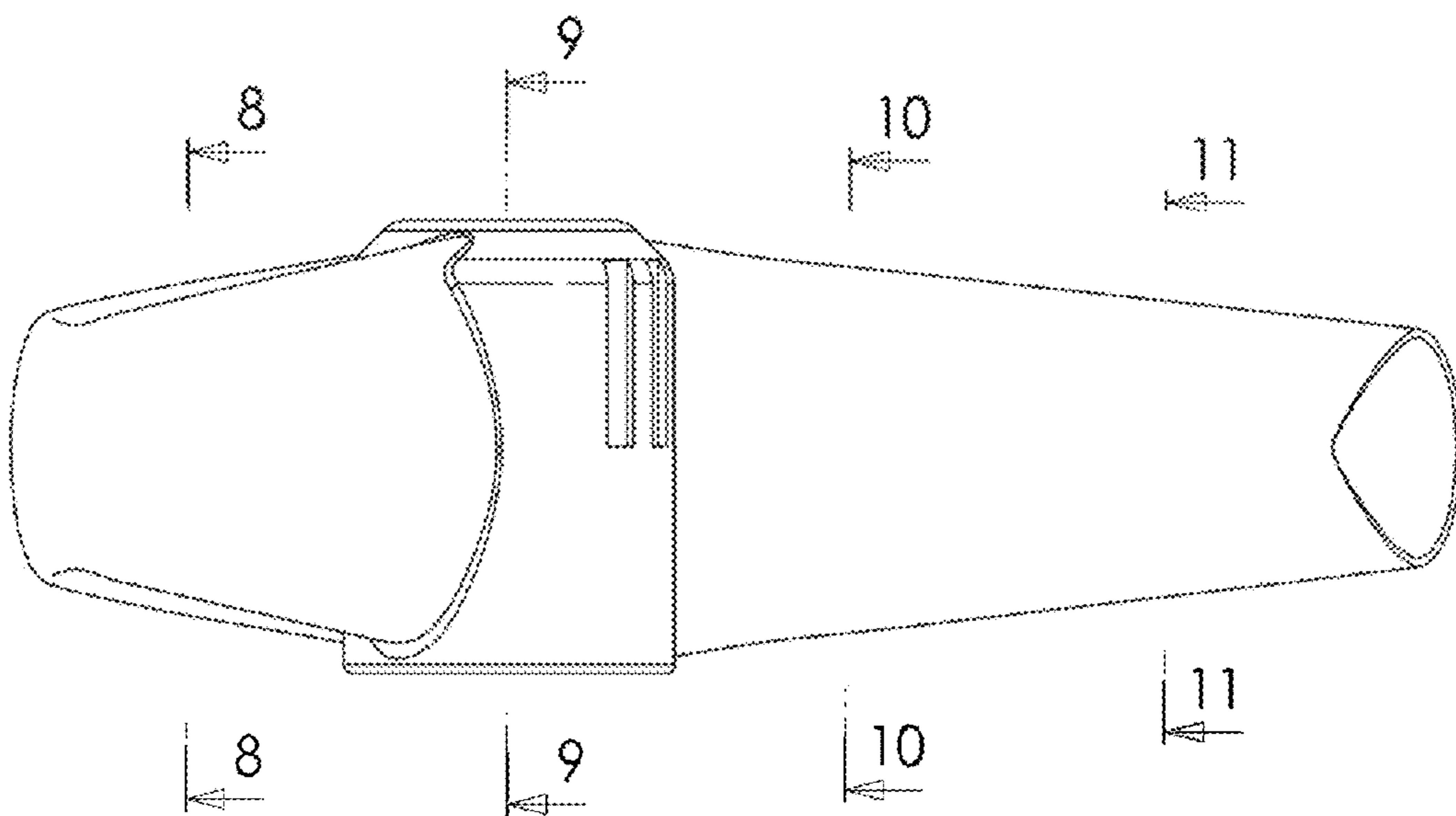

FIG. 7

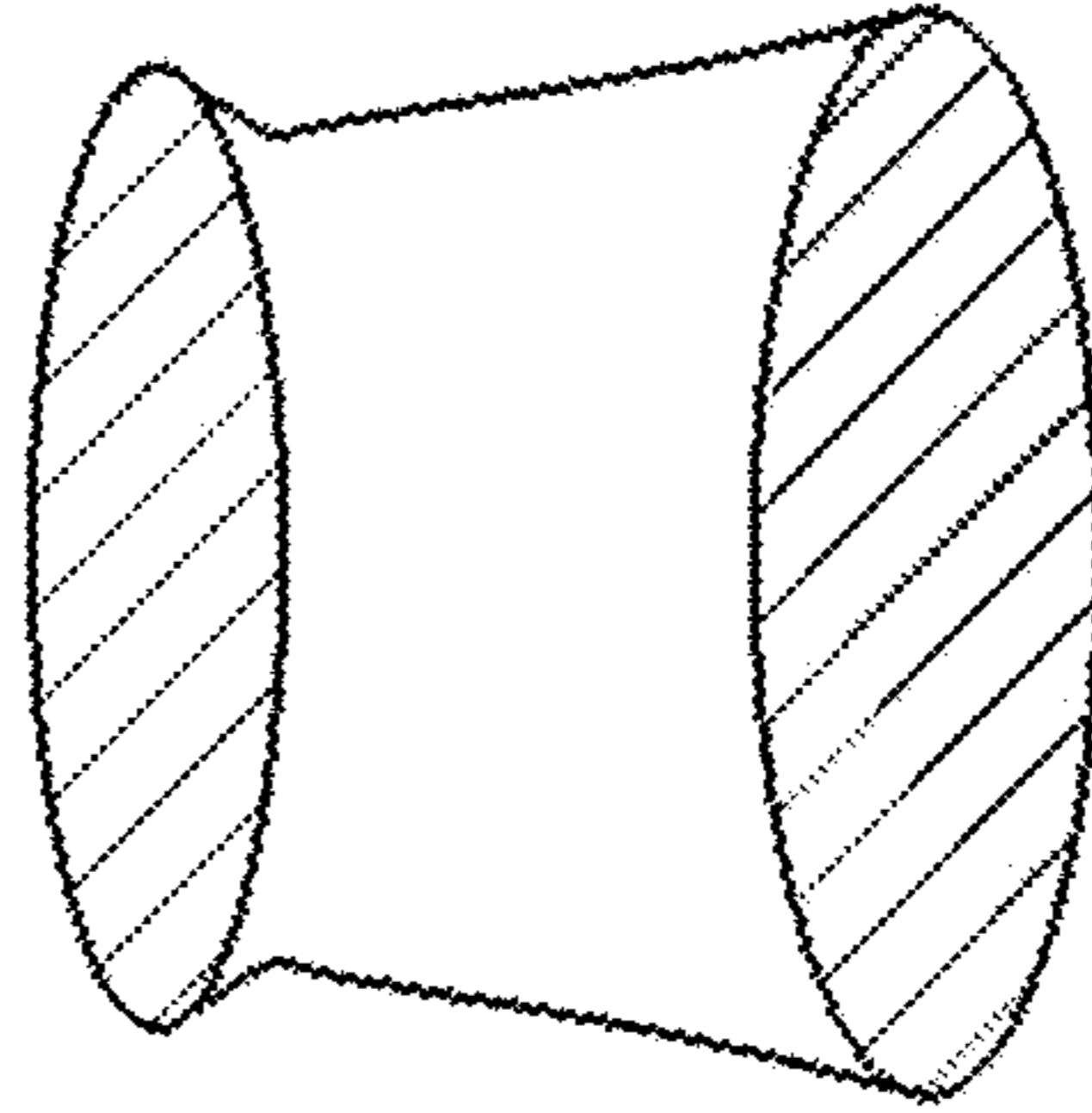

FIG. 8

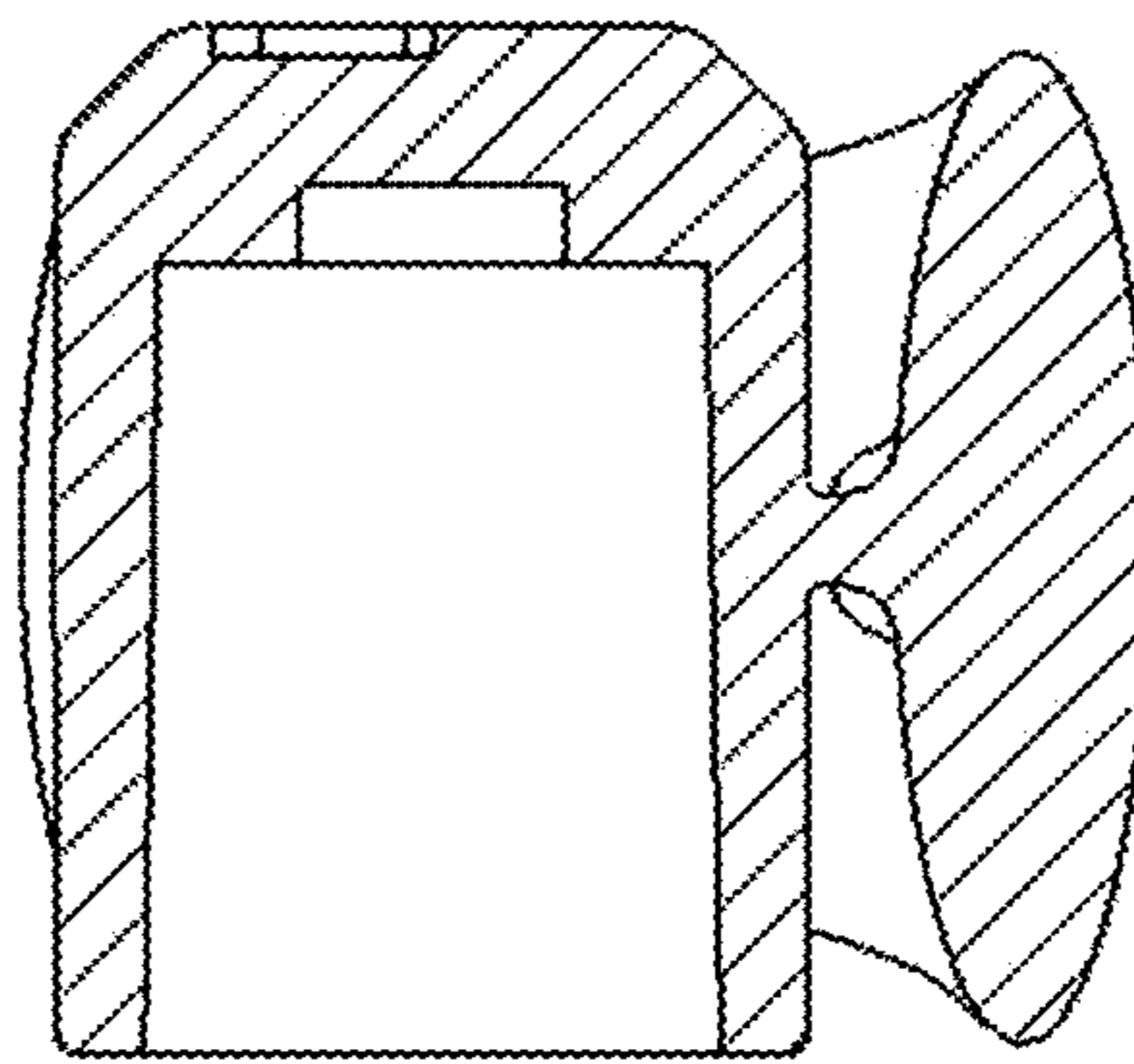

FIG. 9

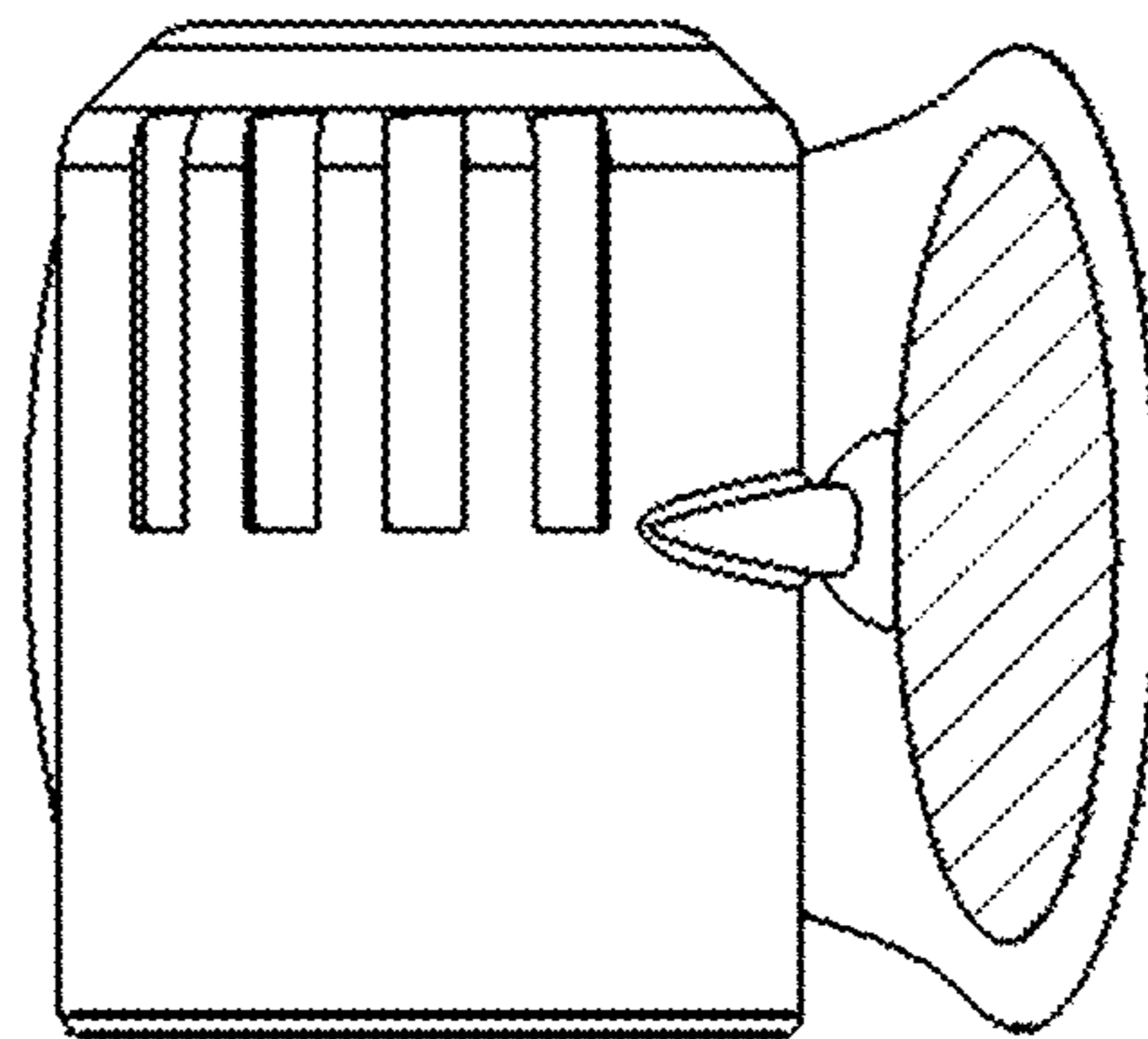

FIG. 10

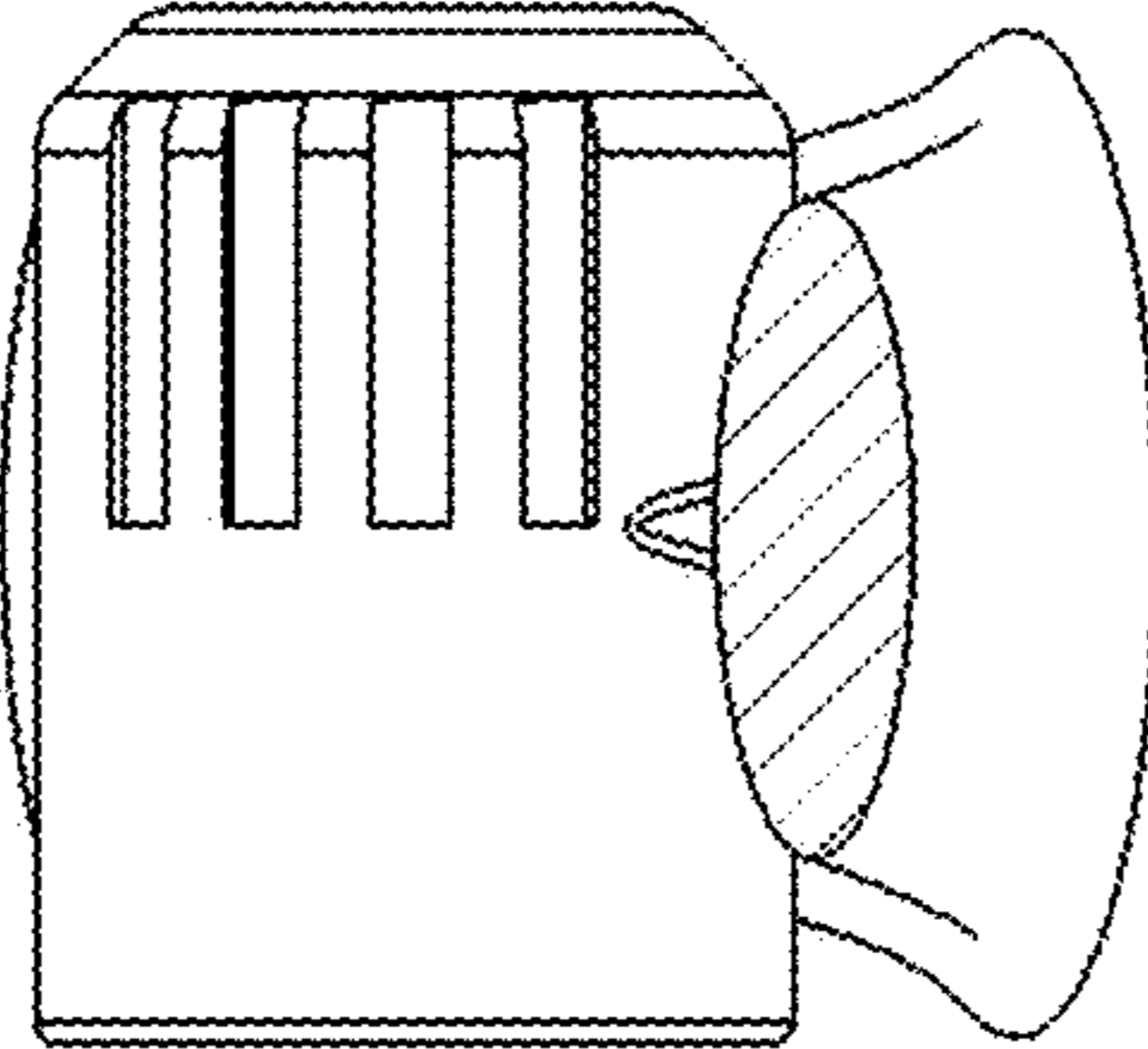

FIG. 11

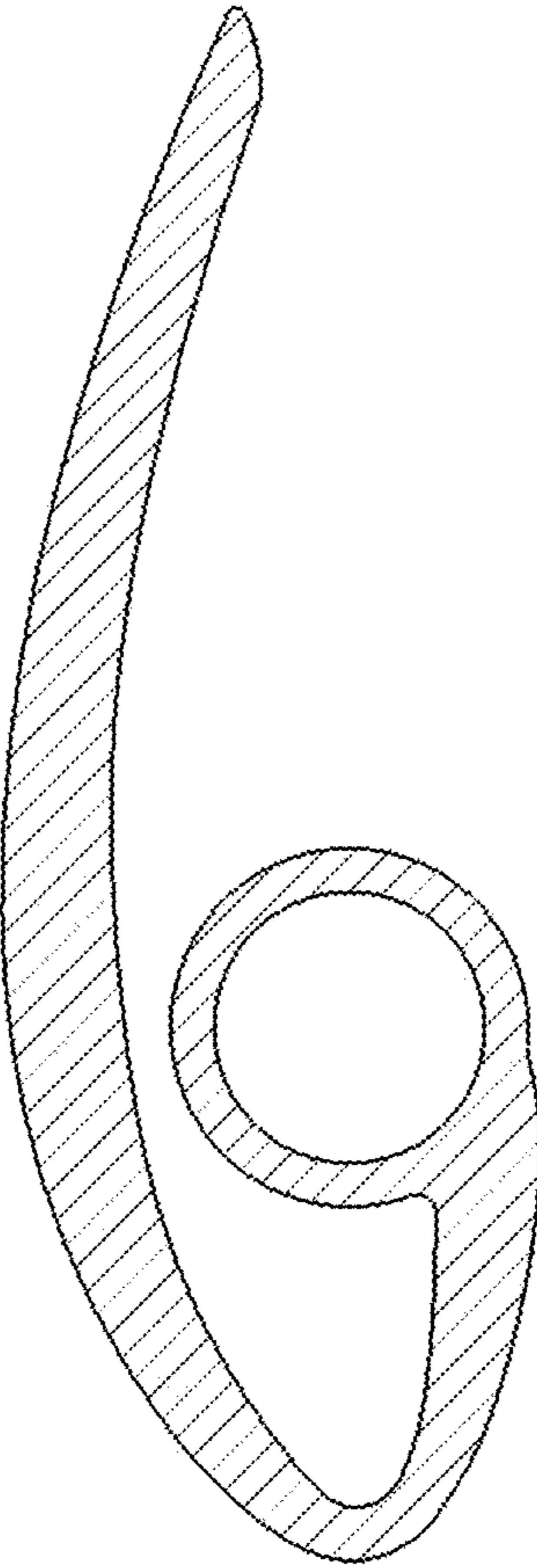

FIG. 12