



US00D749466S

(12) **United States Design Patent**
Nosworthy

(10) **Patent No.:** **US D749,466 S**
(45) **Date of Patent:** **** Feb. 16, 2016**

(54) **PASSENGER VEHICLE CHASSIS REAR CROSSMEMBER**

(71) Applicant: **Dennis Michael Nosworthy**, Coto de Caza, CA (US)

(72) Inventor: **Dennis Michael Nosworthy**, Coto de Caza, CA (US)

(**) Term: **14 Years**

(21) Appl. No.: **29/501,780**

(22) Filed: **Sep. 8, 2014**

(51) **LOC (10) Cl.** **12-16**

(52) **U.S. Cl.**
USPC **D12/159**

(58) **Field of Classification Search**
USPC D12/93, 96, 97, 98, 99, 196; 296/180.1, 296/180.2, 181.1, 183; 280/498, 711, 712, 280/713, 781, 782, 783, 784, 785, 786, 787, 280/788, 797
CPC B62D 25/08; B62D 25/081; B60B 35/04
See application file for complete search history.

(56) **References Cited**

U.S. PATENT DOCUMENTS

3,441,289	A *	4/1969	Ryszewski	B60G 99/00 280/124.109
3,534,977	A *	10/1970	Wessel	B62D 21/02 280/800
4,746,145	A *	5/1988	Furuichi	B60K 17/00 180/312
5,374,081	A *	12/1994	Schoderer	B60G 7/02 280/781
D436,558	S *	1/2001	Fischer	D12/93
D443,848	S *	6/2001	Fischer	D12/93

8,905,437	B2 *	12/2014	Tsuchiya	B62D 21/02 280/124.106
2004/0108705	A1 *	6/2004	Witucki	B62D 29/001 280/781
2006/0087107	A1 *	4/2006	Li	B62D 25/025 280/784
2009/0267337	A1 *	10/2009	Siekaup	B62D 21/02 280/781
2013/0147236	A1 *	6/2013	Lee	B62D 21/11 296/203.02
2013/0241186	A1 *	9/2013	Shibaya	B62D 21/00 280/781
2015/0076805	A1 *	3/2015	Imanishi	B22D 17/22 280/781

* cited by examiner

Primary Examiner — Robert M Spear

Assistant Examiner — Kendra L Hamilton

(74) *Attorney, Agent, or Firm* — Curtis L. Harrington; Harrington & Harrington

(57) **CLAIM**

The ornamental design for a passenger vehicle chassis rear crossmember, as shown and described.

DESCRIPTION

FIG. 1 is a top, rear, left perspective view of a passenger vehicle chassis rear crossmember, showing my new design; FIG. 2 is a rear elevational view thereof; FIG. 3 is a front elevational view thereof; FIG. 4 is a left side elevational view thereof; FIG. 5 is a right side elevational view thereof; FIG. 6 is a bottom plan view thereof; and, FIG. 7 is a top plan view thereof. The broken lines illustrate portions of the passenger vehicle chassis rear crossmember that form no part of the claimed design.

1 Claim, 3 Drawing Sheets

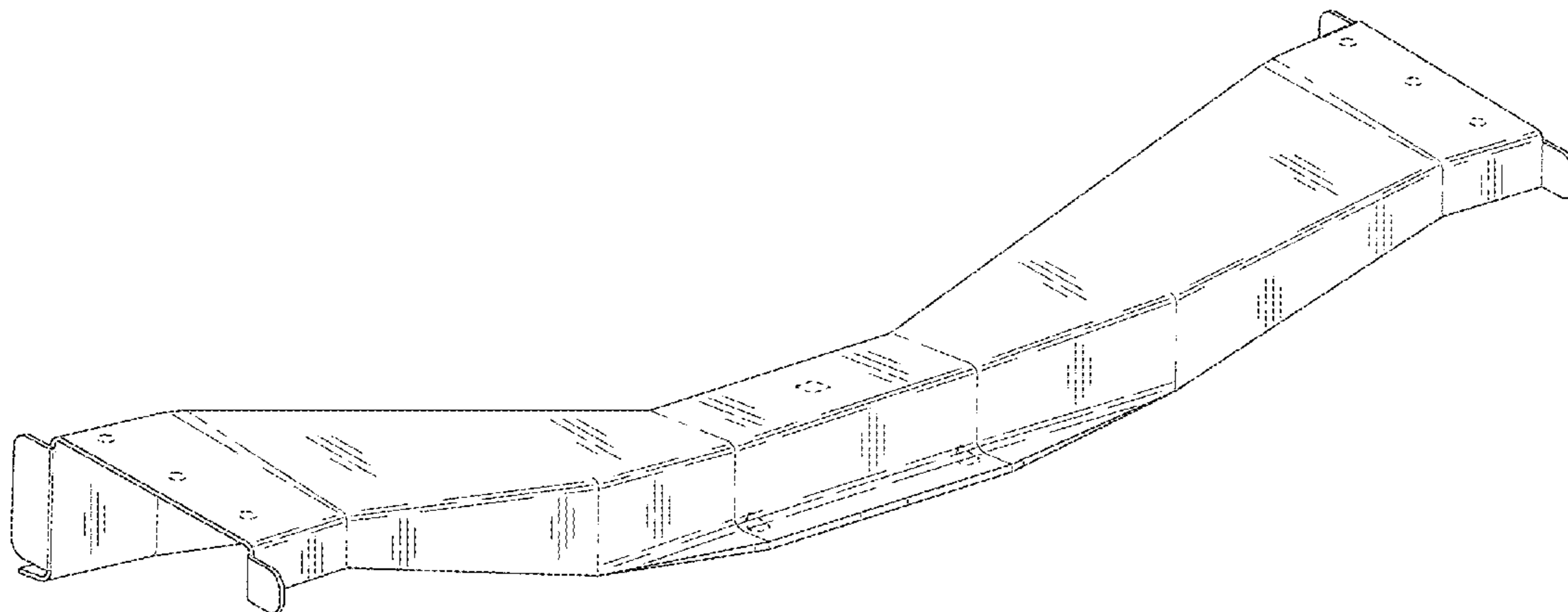

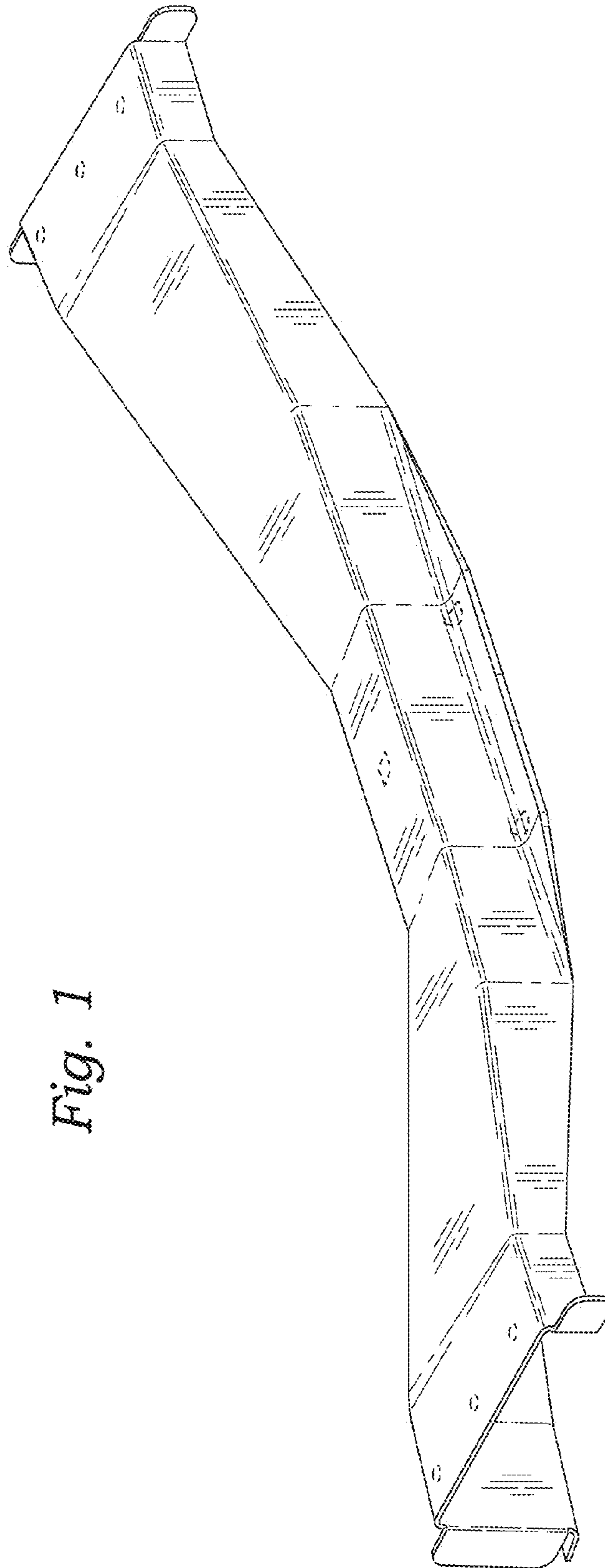

Fig. 1

Fig. 2

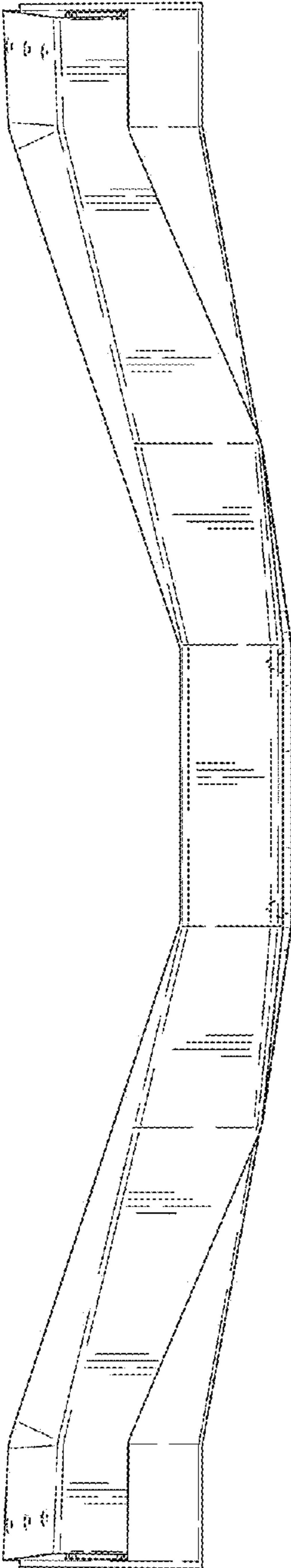

Fig. 3

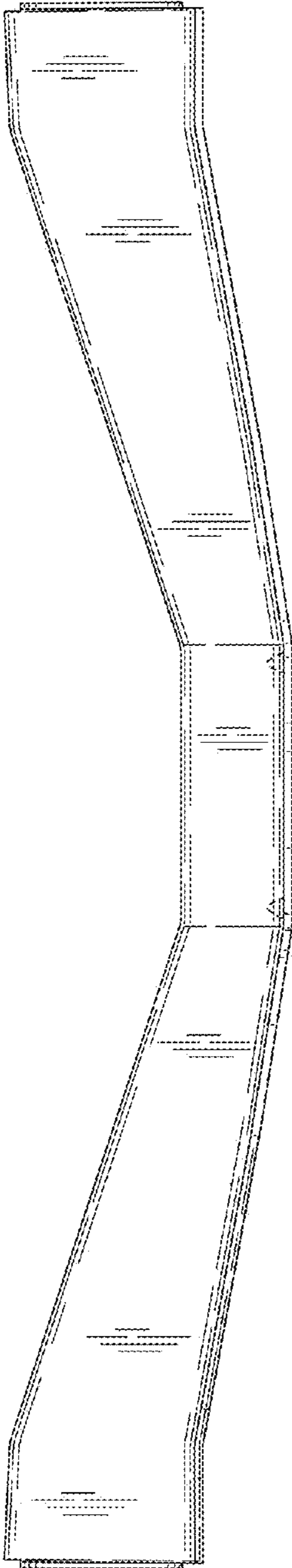

Fig. 4

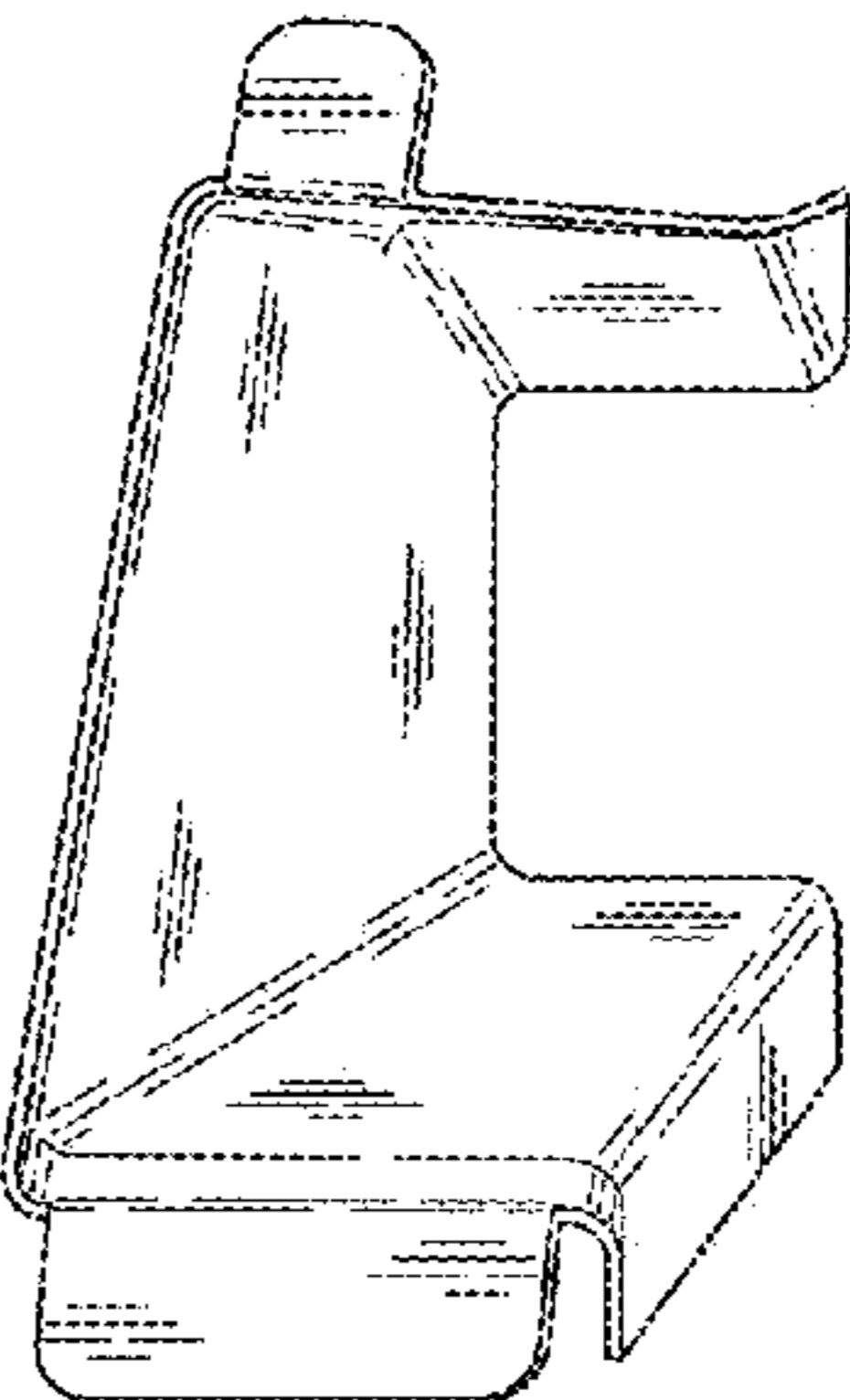

Fig. 5

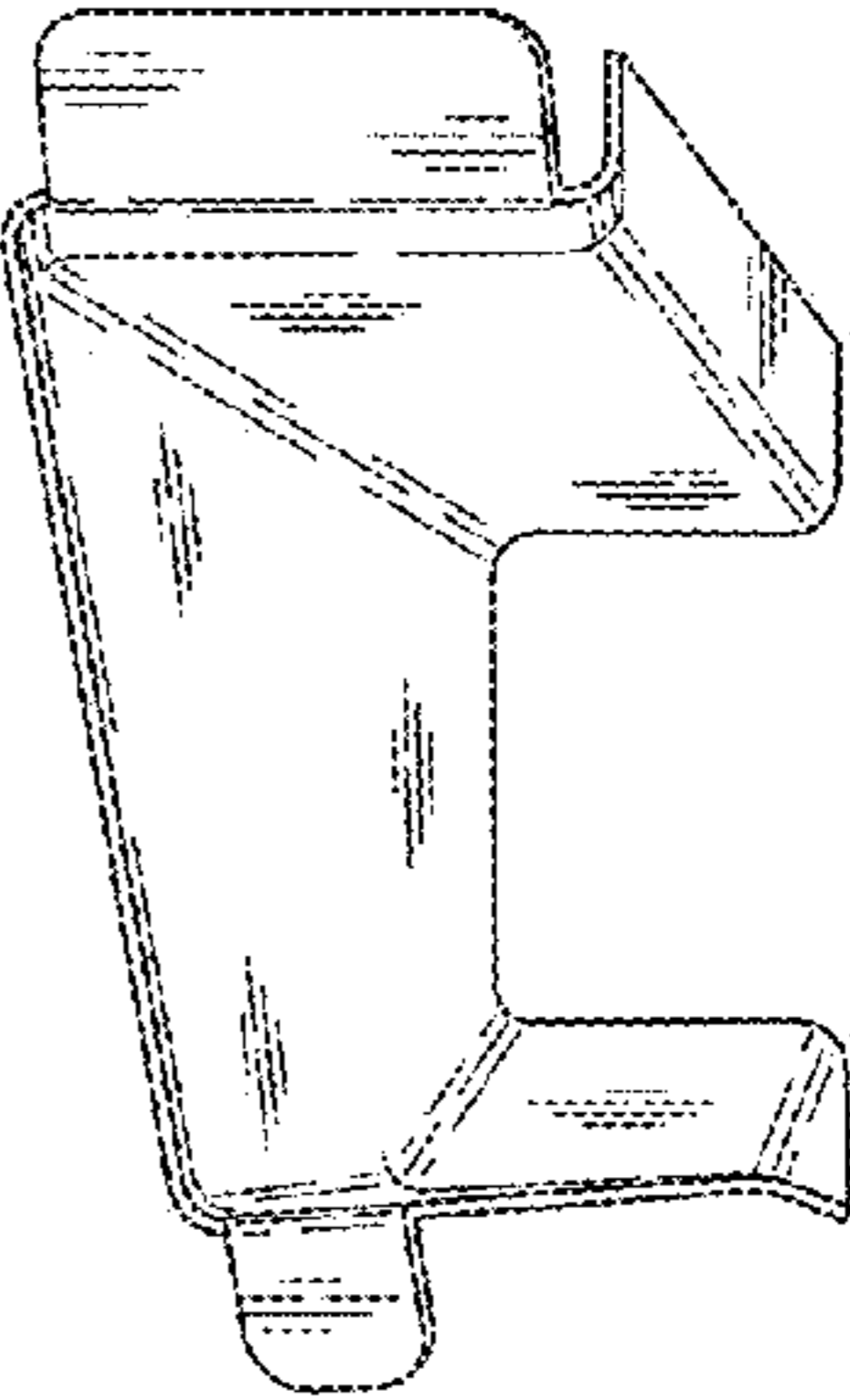

Fig. 6

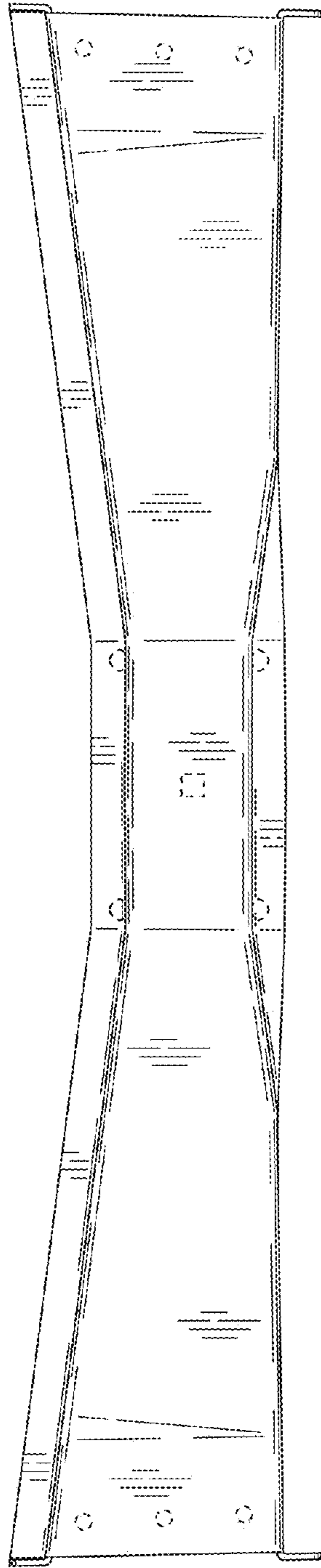

Fig. 7

