



US00D749137S

(12) **United States Design Patent**
Vlosich, III et al.

(10) **Patent No.:** **US D749,137 S**
(45) **Date of Patent:** **** Feb. 9, 2016**

(54) **IMPELLER FOR FLUID AGITATION**

(71) Applicant: **Floatair Agitator Limited Liability Company**, Carlsbad, NM (US)

(72) Inventors: **Joseph Michael Vlosich, III**, Carlsbad, NM (US); **David L. Shanks**, Carlsbad, NM (US)

(**) Term: **14 Years**

(21) Appl. No.: **29/509,724**

(22) Filed: **Nov. 20, 2014**

Related U.S. Application Data

(63) Continuation-in-part of application No. 14/455,377, filed on Aug. 8, 2014.

(51) **LOC (10) Cl.** **15-02**

(52) **U.S. Cl.**
USPC **D15/7**

(58) **Field of Classification Search**
USPC D15/10, 21, 28, 7
CPC F04D 11/00; E21B 21/067; E21B 17/22;
B01D 19/0052
See application file for complete search history.

(56) **References Cited**

U.S. PATENT DOCUMENTS

2,447,595 A 8/1948 Pigott et al.
3,635,092 A 1/1972 Maughan et al.

(Continued)

OTHER PUBLICATIONS

U.S. Appl. No. 14/455,377, Shanks.

(Continued)

Primary Examiner — Mitchell Siegel

(74) *Attorney, Agent, or Firm* — Peter L. Brewer; Baker Donelson IP Group

(57) **CLAIM**

We claim the ornamental design for an impeller for fluid agitation, as shown and described.

DESCRIPTION

FIG. 1 is a perspective view showing a new design for the impeller for fluid agitation, in a first embodiment. The device is standing upright. A bracket indicates that the shaft is of indeterminate length.

FIG. 2 is a front elevation view of the impeller of FIG. 1.

FIG. 3 is a back elevation view of the impeller of FIG. 1, which is opposite the view of FIG. 2.

FIG. 4 is a right side elevation view of the impeller of FIG. 1.

FIG. 5 is a left side elevation view of the impeller of FIG. 1, which is opposite the view of FIG. 4.

FIG. 6 is a top or plan view of the impeller of FIG. 1.

FIG. 7 is a bottom view of the impeller of FIG. 1.

FIG. 8 is a perspective view showing a new design for the impeller for fluid agitation, in a second embodiment. The device is standing upright. A bracket indicates that the shaft is of indeterminate length.

FIG. 9 is a front elevation view of the impeller of FIG. 8.

FIG. 10 is a back elevation view of the impeller of FIG. 8, which is opposite the view of FIG. 9.

FIG. 11 is a right side elevation view of the impeller of FIG. 8.

FIG. 12 is a left side elevation view of the impeller of FIG. 8, which is opposite the view of FIG. 11.

FIG. 13 is a top or plan view of the impeller of FIG. 8; and, FIG. 14 is a bottom view of the impeller of FIG. 8.

The features shown in broken lines depict portions of the impeller for fluid agitation that form no part of the claimed design. The bracket along the shafts indicate indeterminate length.

1 Claim, 8 Drawing Sheets

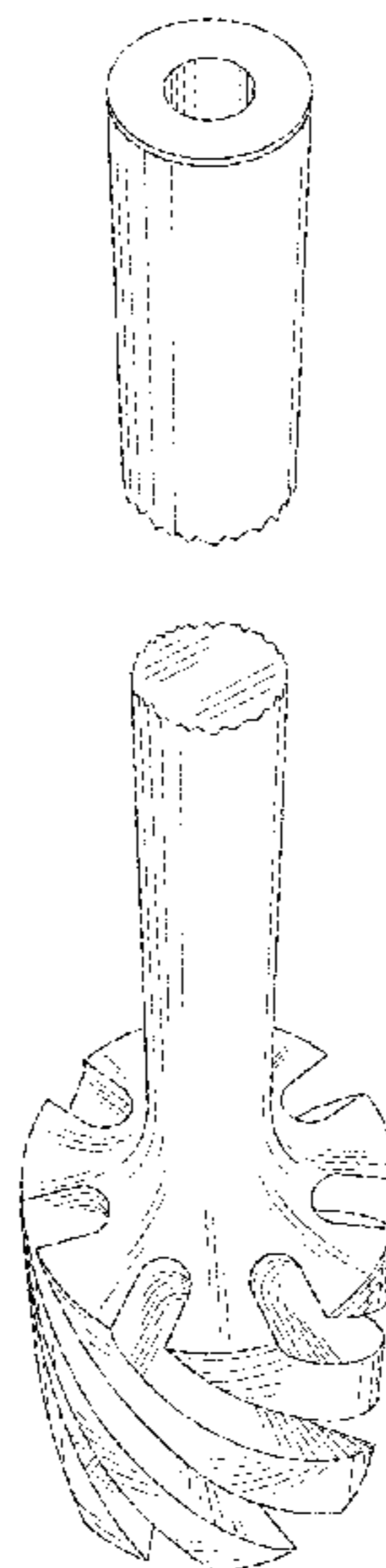

(56)

References Cited

U.S. PATENT DOCUMENTS

3,699,814 A 10/1972 Kaufman
 3,817,100 A 6/1974 Anderson et al.
 3,884,081 A 5/1975 Griffith
 4,040,299 A 8/1977 Snyder
 D258,588 S * 3/1981 Sugiura D15/7
 D258,589 S * 3/1981 Sugiura D15/7
 4,272,258 A 6/1981 Shifflett
 4,358,298 A 11/1982 Ratcliff
 4,367,078 A 1/1983 Hendrix
 D268,112 S * 3/1983 Sugiura D15/7
 4,984,633 A * 1/1991 Langer E21B 17/22
 166/173
 5,161,417 A 11/1992 Strong et al.
 5,199,509 A 4/1993 Wright et al.
 5,621,180 A 4/1997 Simon et al.
 D382,881 S * 8/1997 Hoglund D15/7
 5,902,378 A 5/1999 Obrejanu
 D427,610 S * 7/2000 Raible D15/7
 6,389,878 B1 5/2002 Zamfes
 7,350,536 B2 4/2008 Evans
 7,655,079 B2 2/2010 Lai et al.
 7,741,605 B2 6/2010 Gunn et al.
 7,794,527 B2 9/2010 Sterner
 7,814,782 B2 10/2010 DiFoggio
 7,844,400 B1 11/2010 Selman et al.
 7,957,903 B1 6/2011 Selman et al.
 8,336,645 B2 * 12/2012 Robson E21B 17/10
 166/241.6
 8,632,625 B2 1/2014 DeGreeve et al.
 8,720,287 B2 5/2014 Haney
 2002/0043620 A1 4/2002 Tchakarov et al.
 2002/0096368 A1 * 7/2002 Kirk E21B 17/1064
 175/385
 2004/0010587 A1 1/2004 Altamirano et al.
 2005/0132889 A1 6/2005 MacDuff
 2007/0056773 A1 * 3/2007 Booth E21B 17/22
 175/57
 2008/0047370 A1 2/2008 Vickery, Jr.
 2009/0136298 A1 5/2009 Augenstein et al.

2012/0000278 A1 1/2012 Phillips
 2013/0042666 A1 2/2013 Santucci et al.
 2013/0275047 A1 10/2013 Selman et al.
 2015/0211311 A1 * 7/2015 Shanks E21B 21/067
 95/8

OTHER PUBLICATIONS

www.usgeosupply.com website showing USGI gas trap agitators and stands accessed Sep. 5, 2014 published 2010.
 www.usgeosupply.com website showing Ratcliff gas trap agitators and stands accessed Sep. 5, 2014 published 2012.
 www.usgeosupply.com web page showing Mudlogger's gas trap accessed Sep. 5, 2014 published Jan. 2014.
 www.usgeosupply.com web page showing USGI and Ratcliff gas trap jack accessed Sep. 5, 2014 published Jan. 2014.
 www.usgeosupply.com web page showing USGI and Ratcliff gas trap jack with frame accessed Sep. 5, 2014 published Jan. 2014.
 www.usgeosupply.com web page showing 6" gas trap accessed Sep. 5, 2014 published 2010.
 www.usgeosupply.com web page showing 5" gas trap accessed Sep. 5, 2014 published 2010.
 www.usgeosupply.com web page showing 5" AM gas trap no post or jack accessed Sep. 5, 2014 published 2010.
 www.usgeosupply.com web page showing USGI gas trap only, no motor accessed Sep. 5, 2014 published 2010.
 www.usgeosupply.com web page showing universal mount for gas trap accessed Sep. 5, 2014 published 2010.
 www.iballinstruments.com website showing the Cavitator brand Mud Gas Extractor accessed Sep. 5, 2014 published 2013.
 www.iballinstruments.com pdf link showing the Cavitator Gas Extractor Data Sheet accessed Sep. 5, 2014 published Mar. 2014.
 www.iballinstruments.com pdf link showing the Cavitator Gas Extractor Manual accessed Sep. 5, 2014 published Mar. 2014.
 www.petrowiki.org web page discussing surface data sensors during drilling accessed Sep. 5, 2014 published continuously.
 www.rigsat.com website showing the Portable Gas Detector and Agitator accessed Sep. 5, 2014 published Mar. 2014.

* cited by examiner

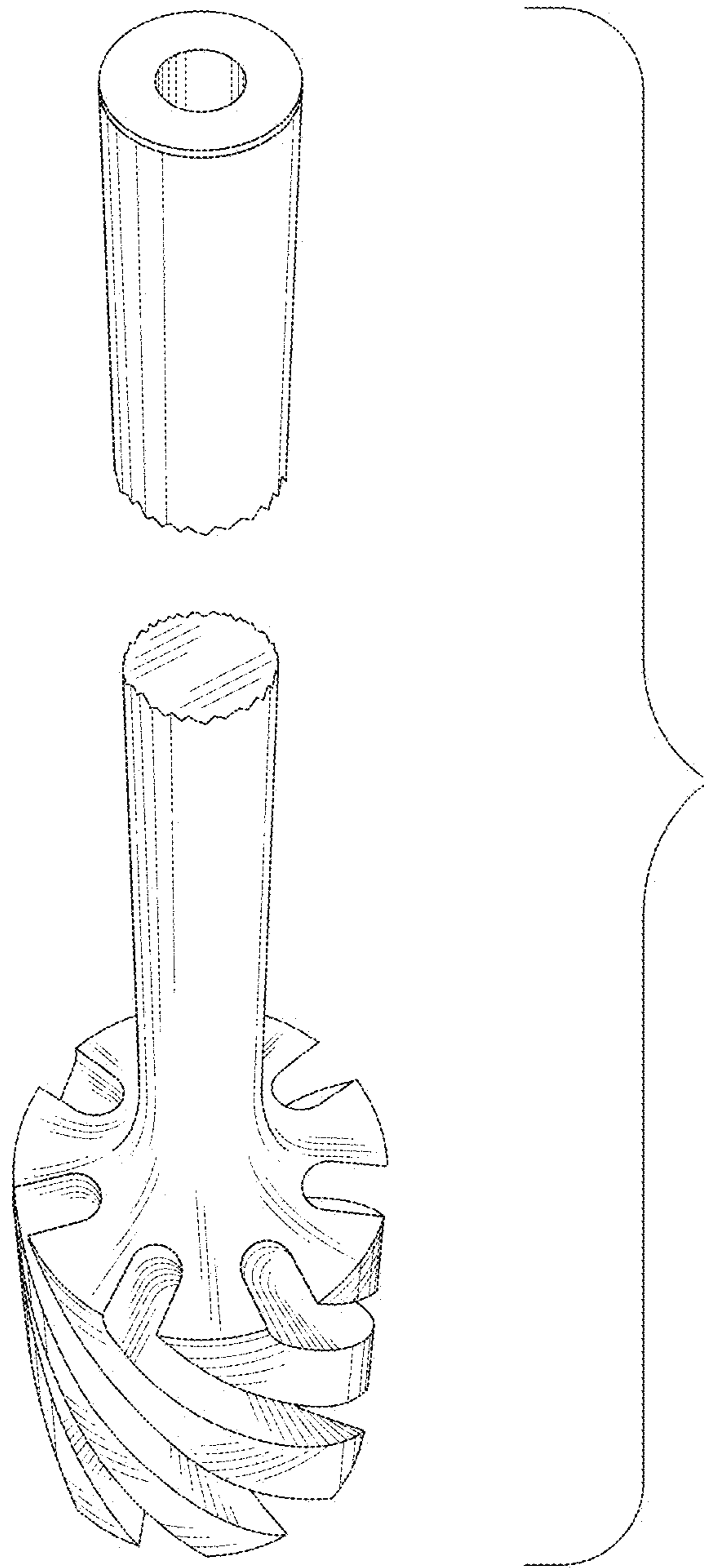

FIG. 1

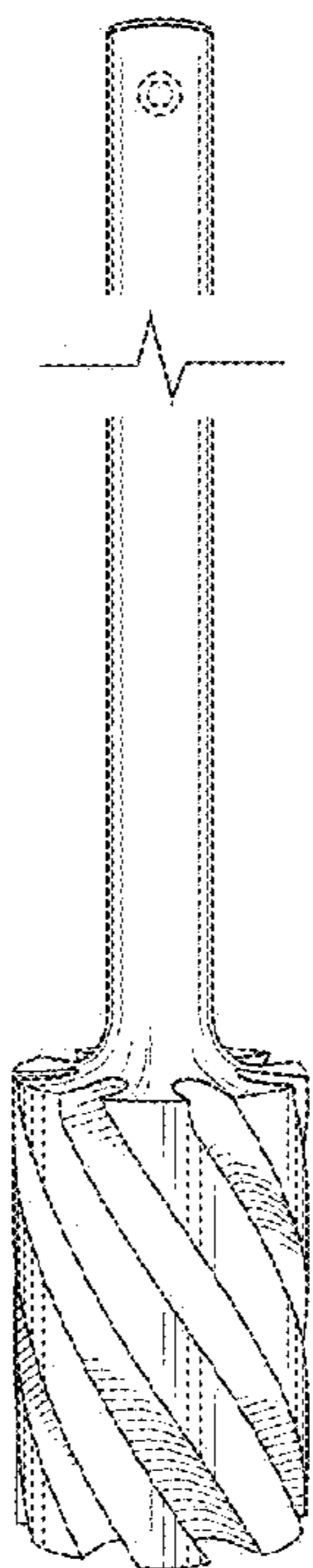

FIG. 2

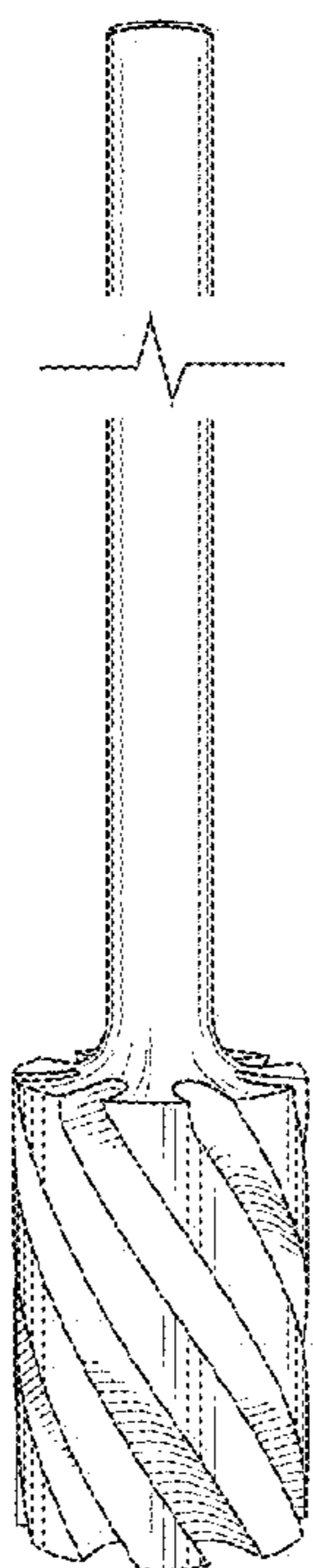

FIG. 3

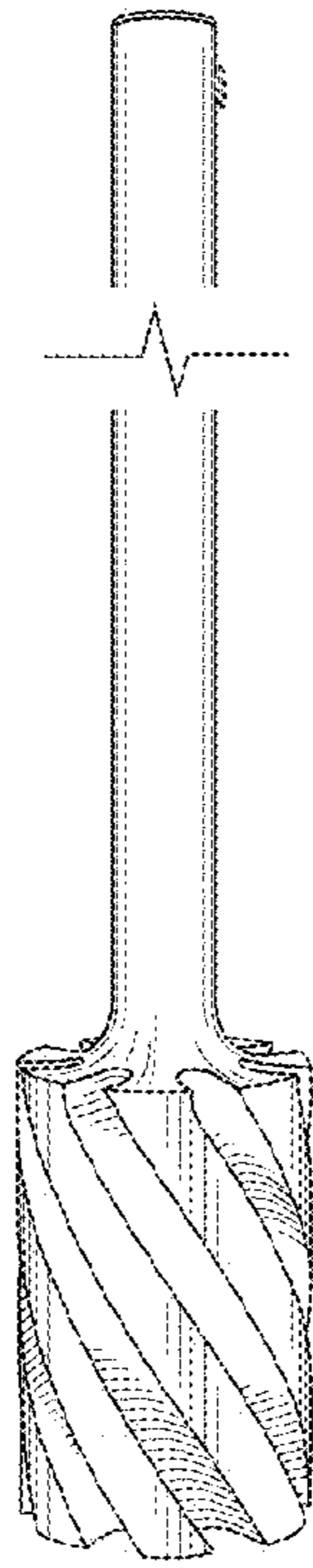

FIG. 4

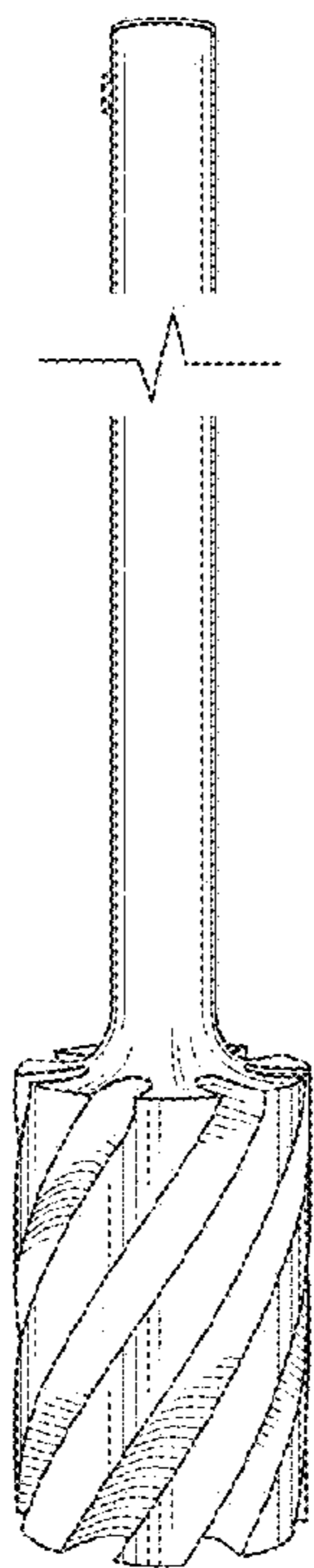

FIG. 5

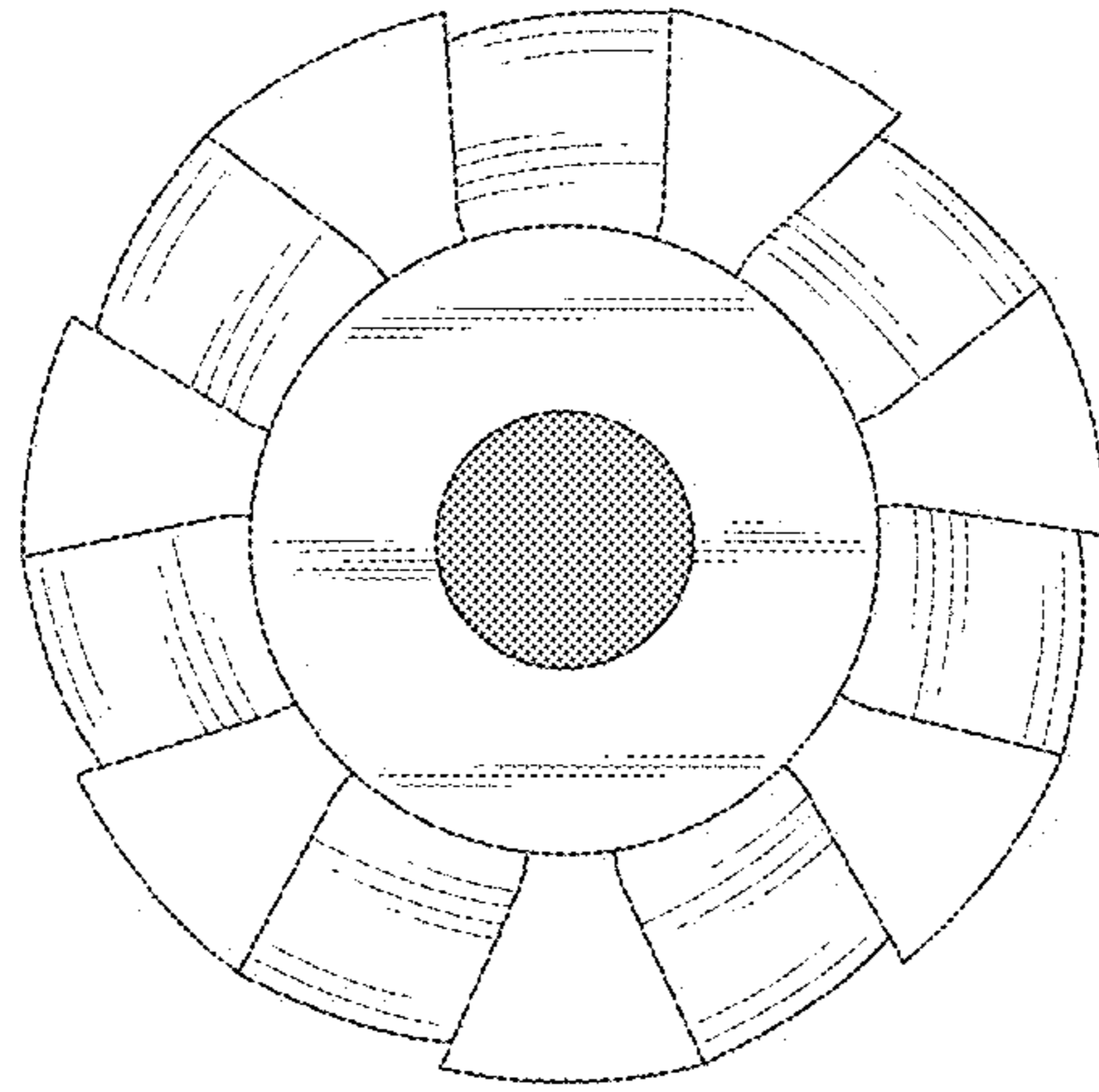

FIG. 6

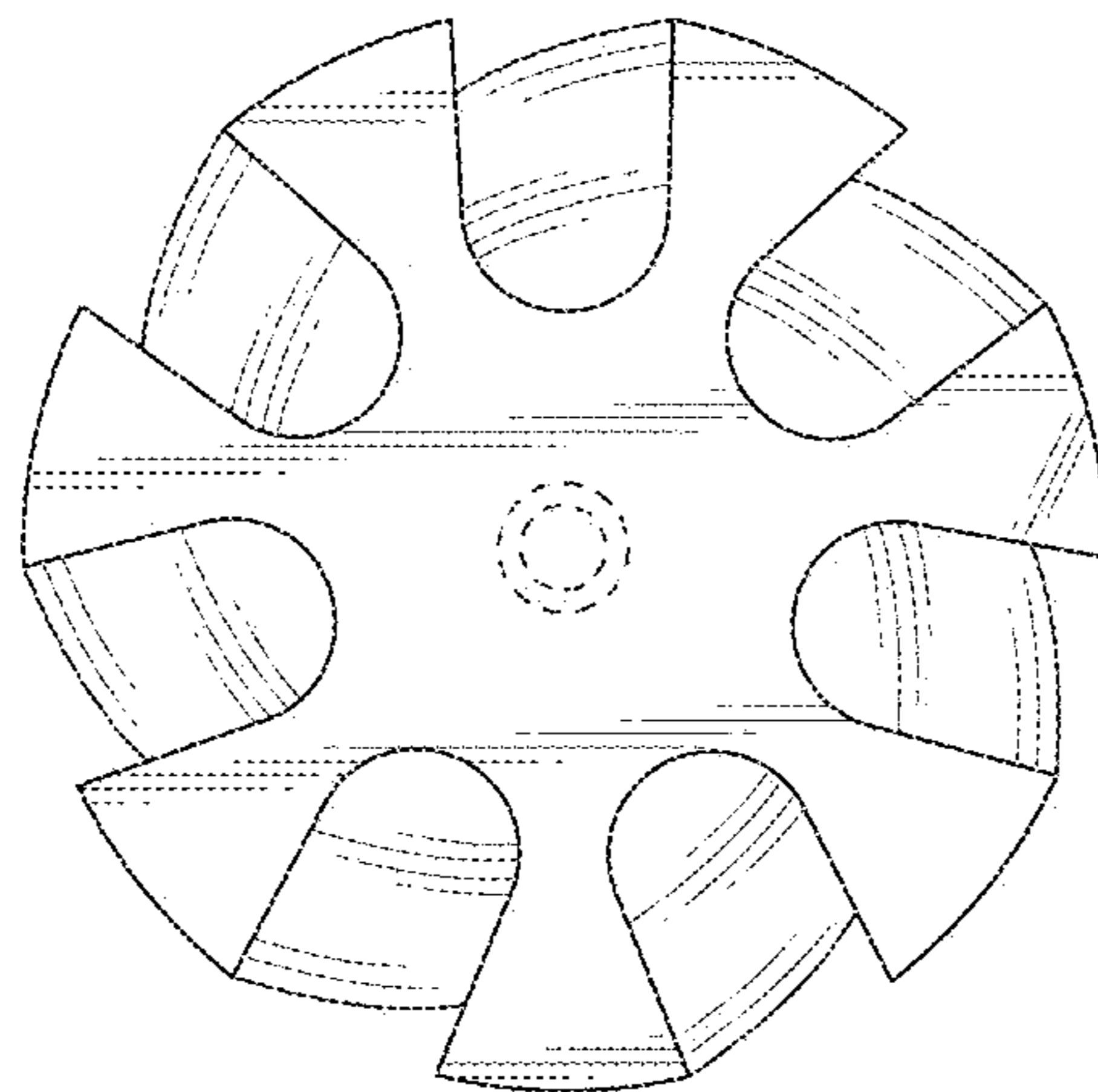

FIG. 7

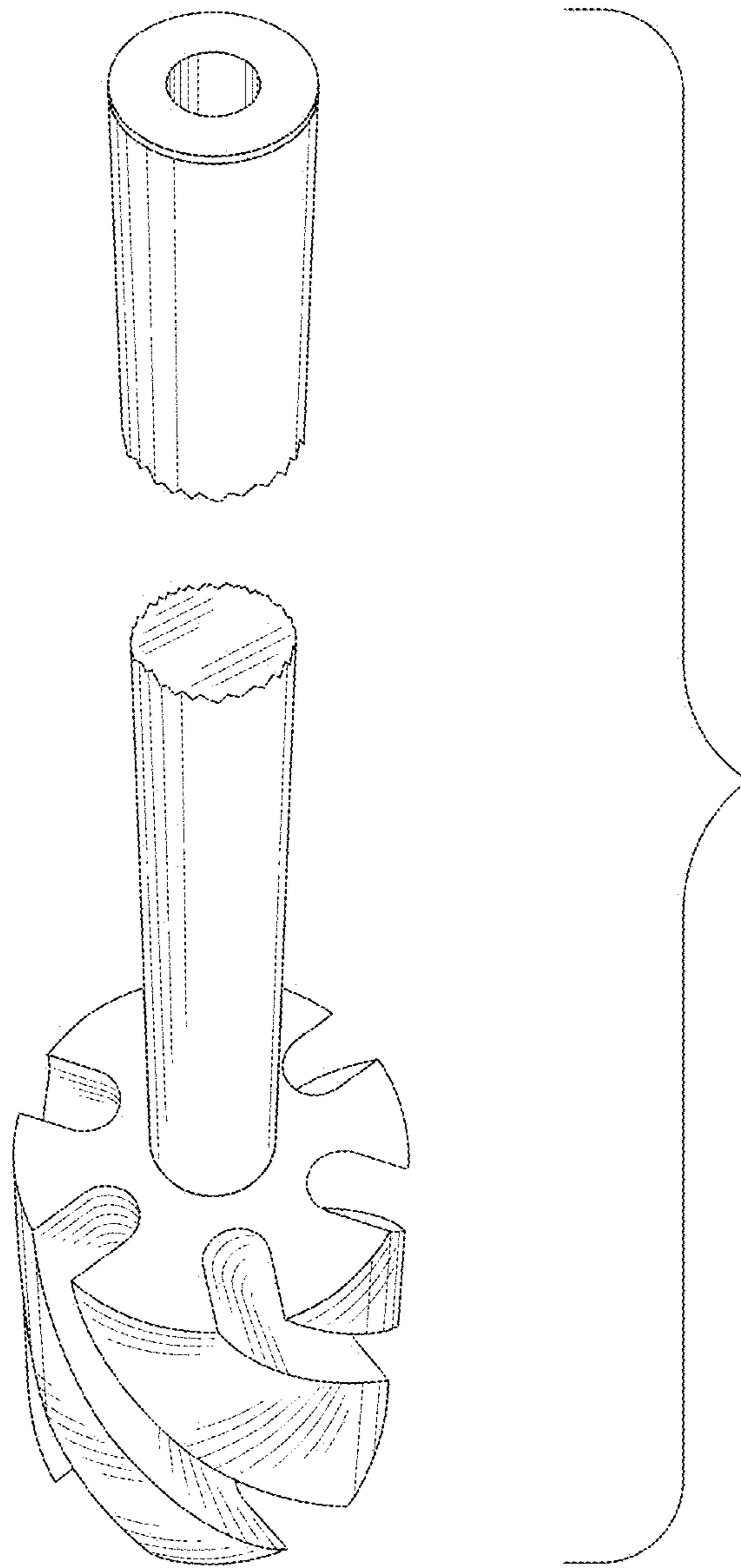

FIG. 8

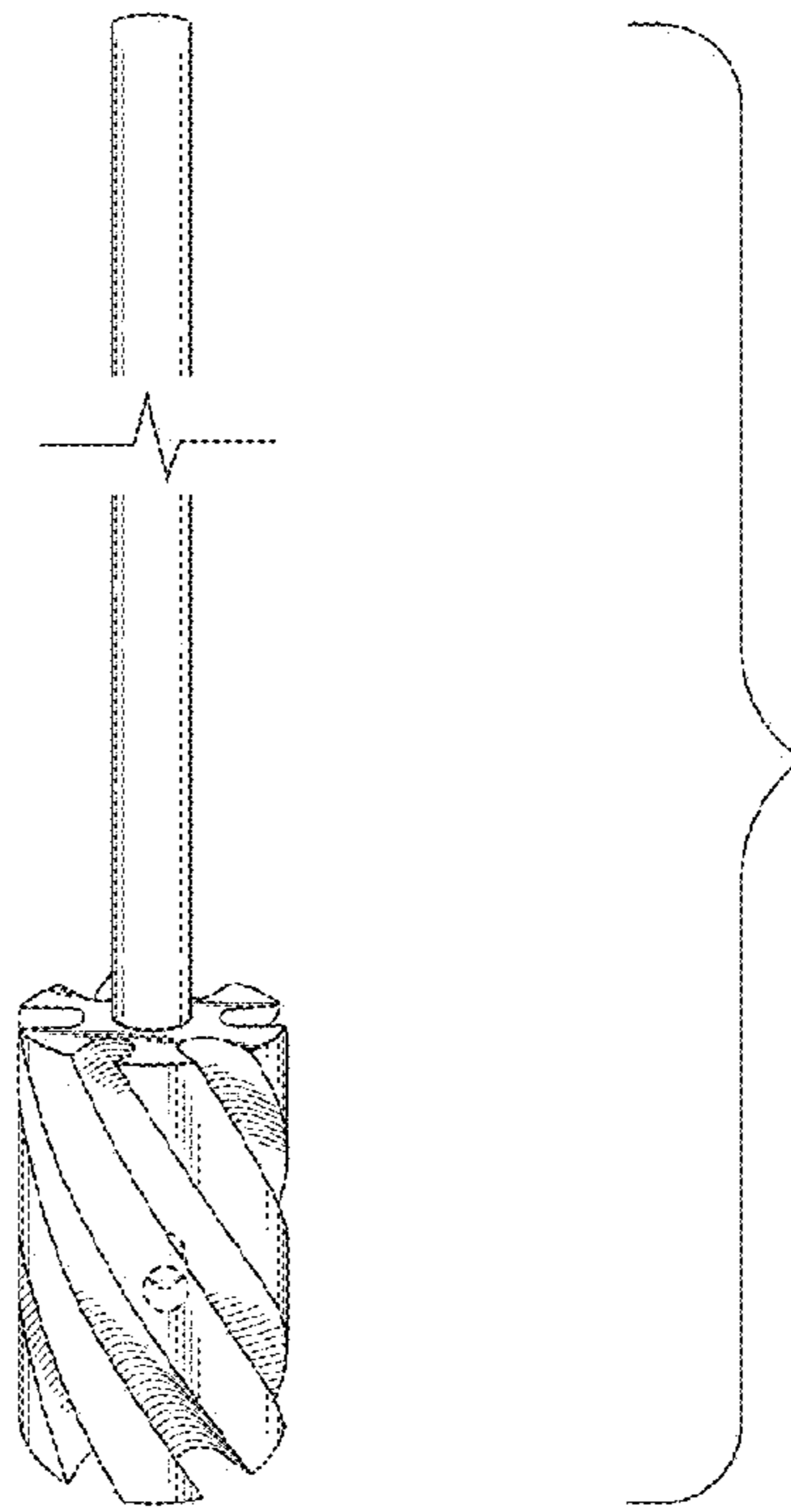

FIG. 9

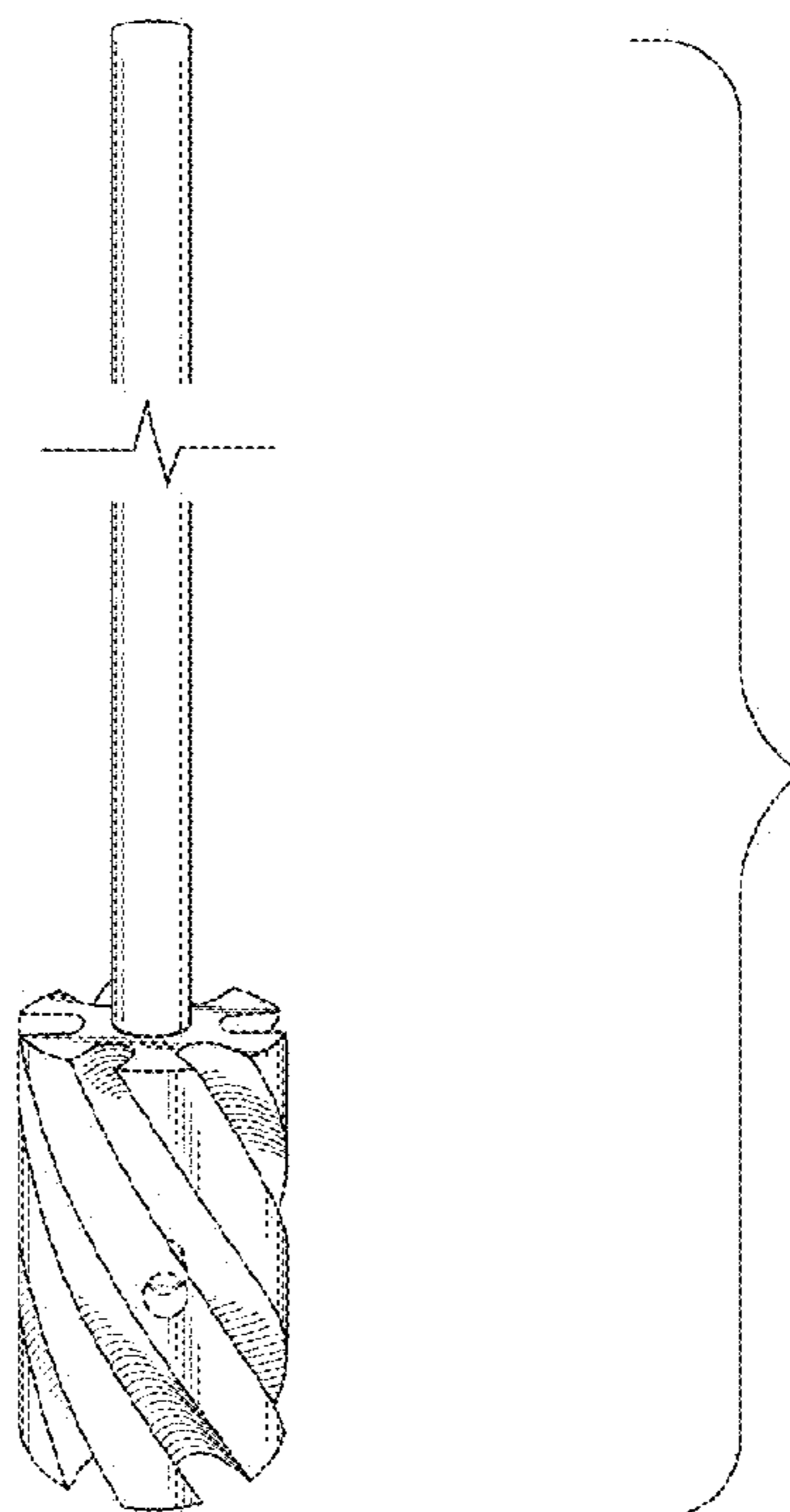

FIG. 10

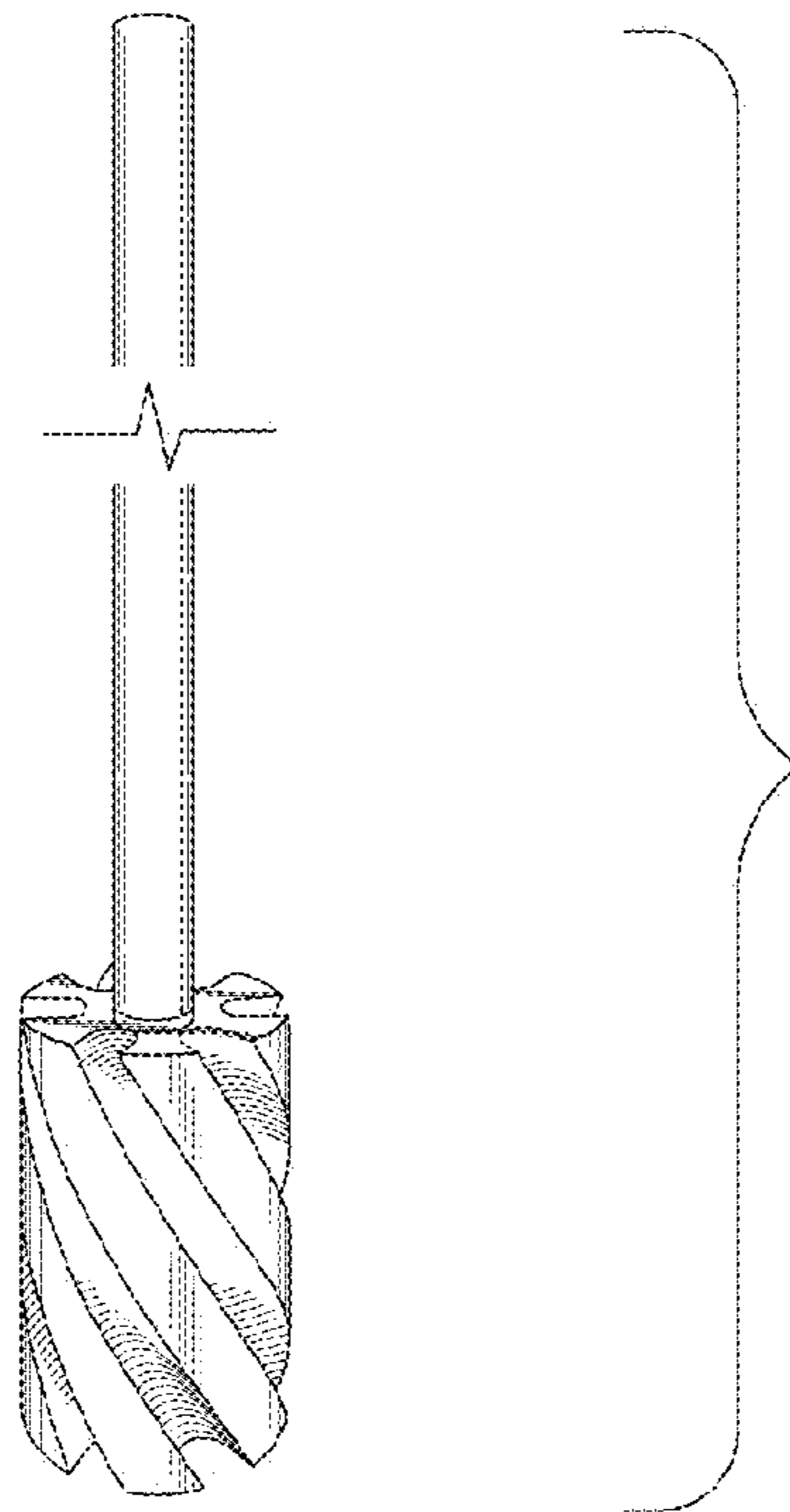

FIG. 11

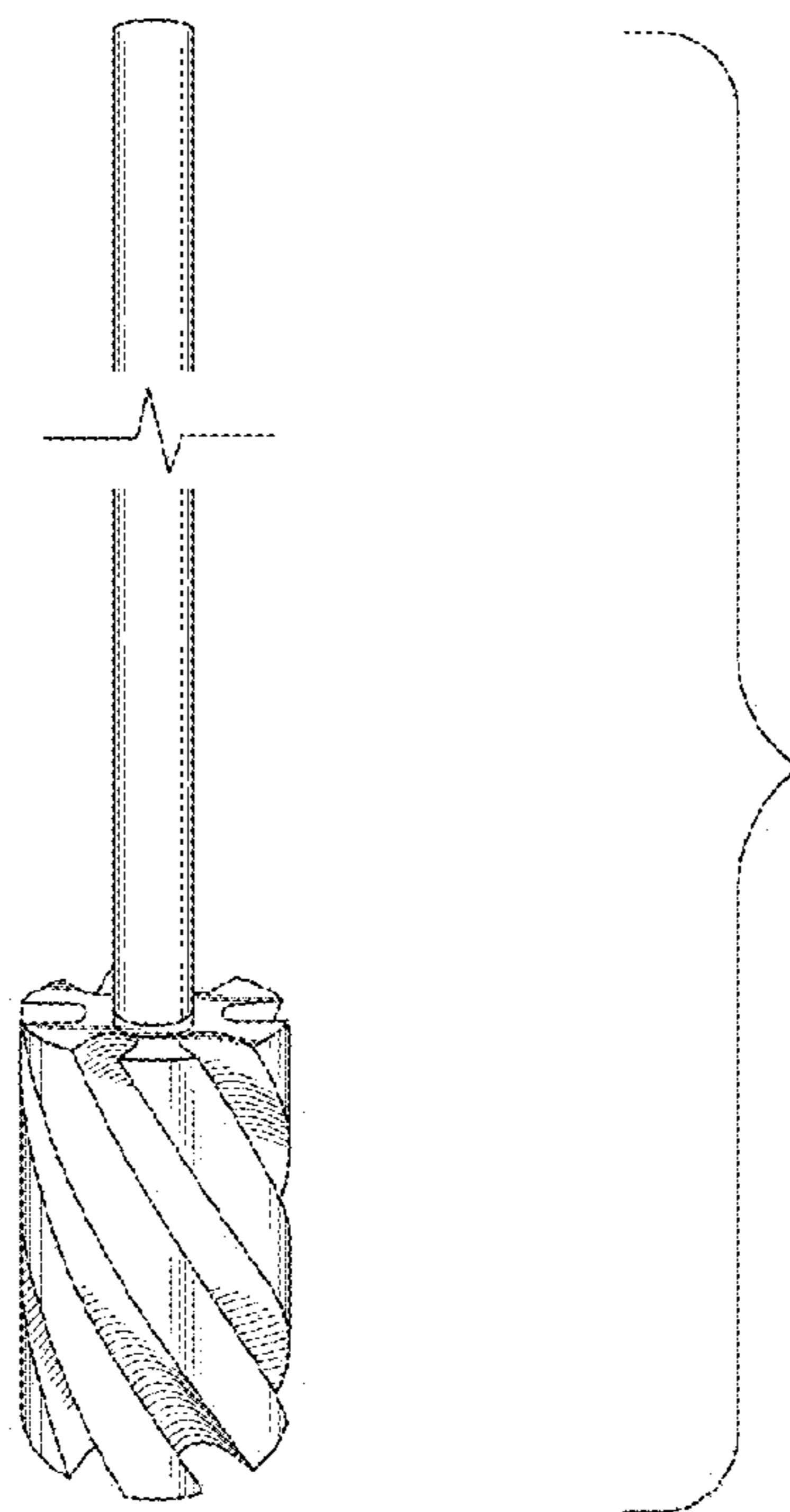

FIG. 12

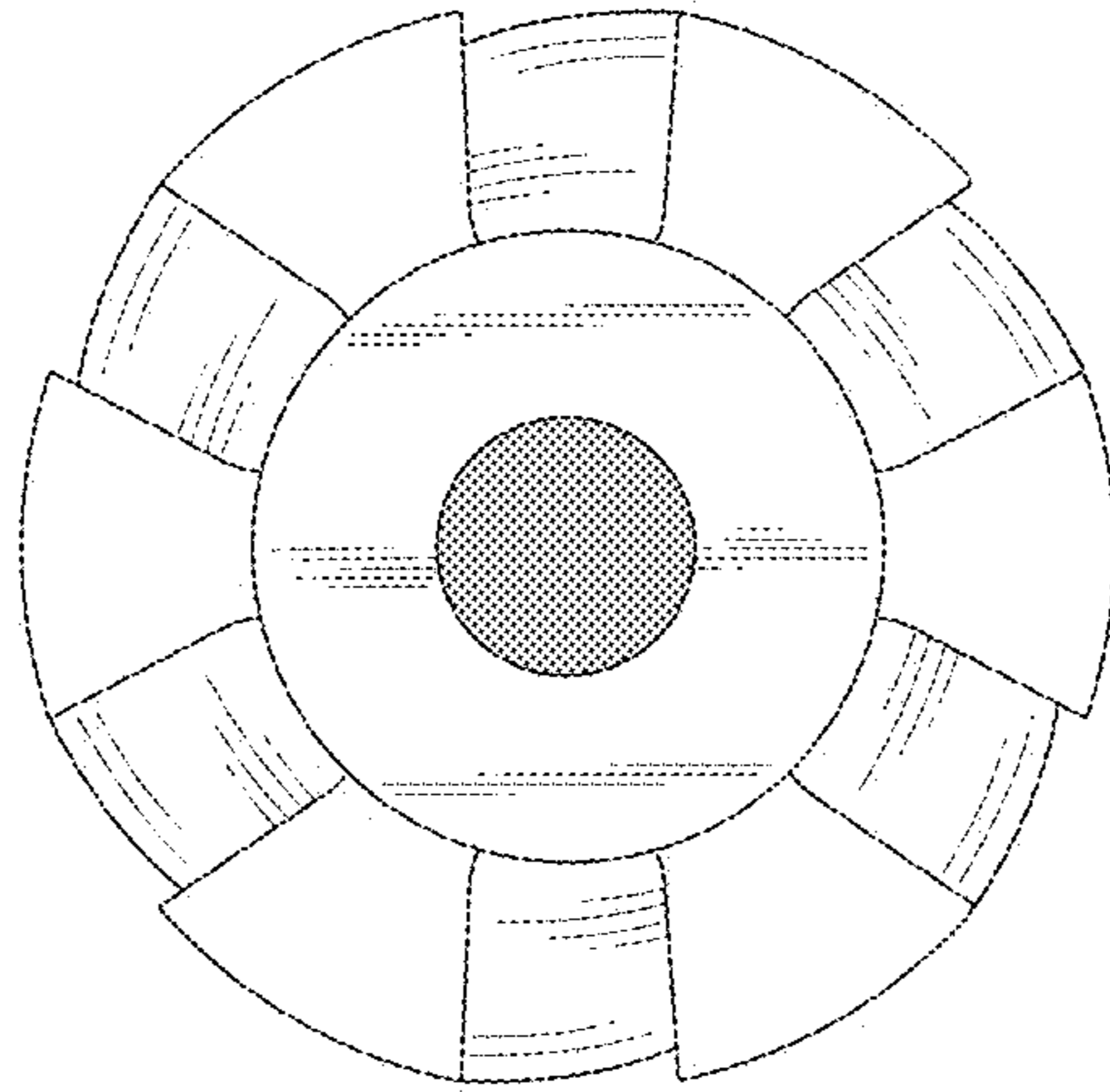

FIG. 13

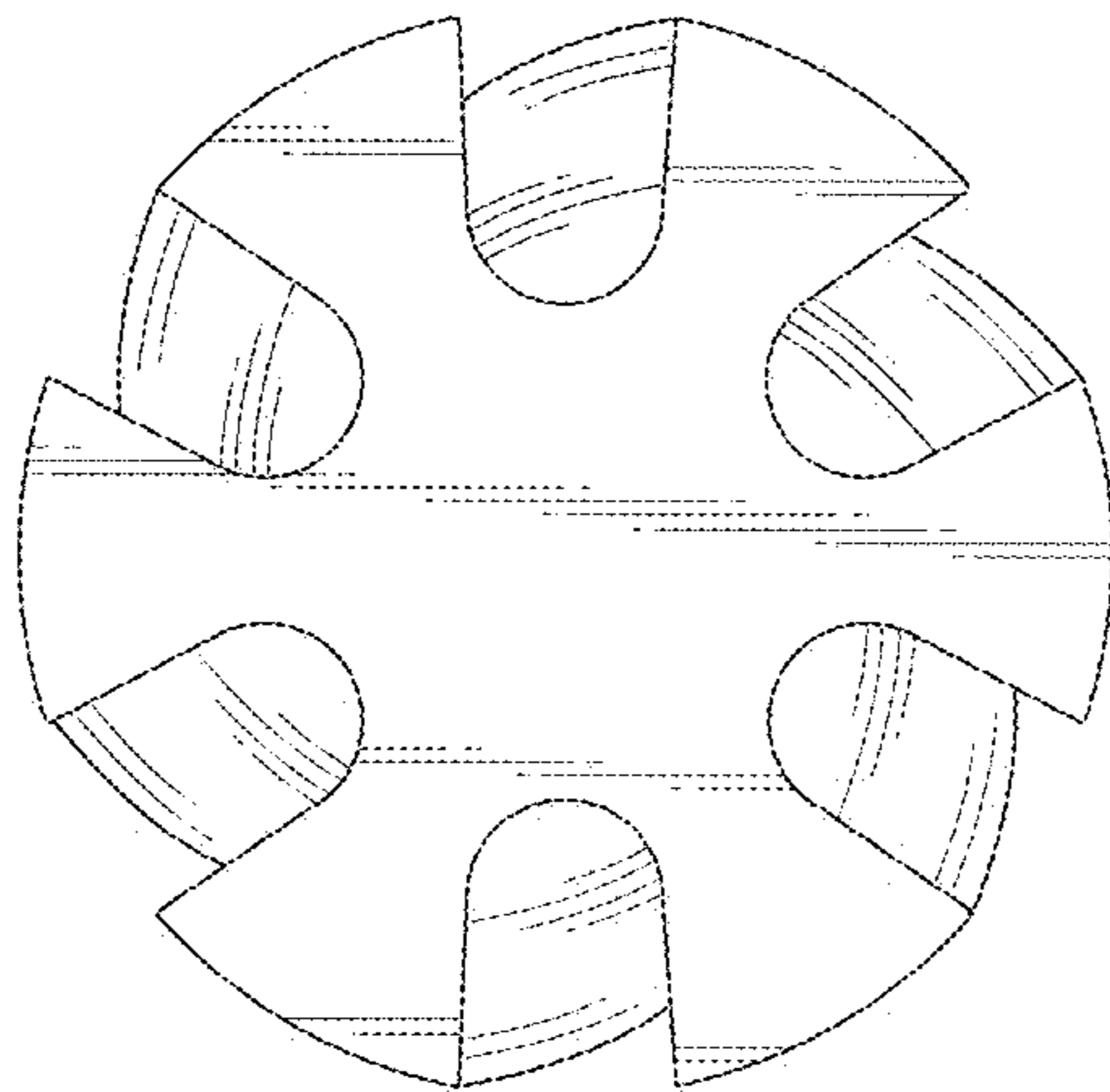

FIG. 14