



US00D748972S

(12) **United States Design Patent**
Primeau et al.

(10) **Patent No.:** **US D748,972 S**

(45) **Date of Patent:** **** Feb. 9, 2016**

(54) **CASTLE CAP ASSEMBLY**

(71) Applicants: **Daniel F. Primeau**, Clarence, NY (US);
Dennis E. Portka, Hamburg, NY (US);
Paul H. Lawrence, Buffalo, NY (US)

(72) Inventors: **Daniel F. Primeau**, Clarence, NY (US);
Dennis E. Portka, Hamburg, NY (US);
Paul H. Lawrence, Buffalo, NY (US)

(**) Term: **14 Years**

(21) Appl. No.: **29/496,313**

(22) Filed: **Jul. 11, 2014**

(51) **LOC (10) Cl.** **08-08**

(52) **U.S. Cl.**
USPC **D8/397**

(58) **Field of Classification Search**
USPC D8/397, 394, 382, 349, 312, 107, 399;
D11/222; D2/869
CPC F16L 19/0206; B60B 3/16; F16B 39/26;
F16B 39/24; F16B 37/02; F16B 31/02;
H01R 9/0524

See application file for complete search history.

(56) **References Cited**

U.S. PATENT DOCUMENTS

D449,515	S	*	10/2001	Sato	D8/397
D581,777	S	*	12/2008	Huang	D8/397
D623,049	S	*	9/2010	Zeyfang	D8/397
D649,031	S	*	11/2011	Rand	D8/397
D654,421	S	*	2/2012	Sugiyama	D12/400
D704,543	S	*	5/2014	Kuhmichel	D8/397
D713,705	S	*	9/2014	Mina	D8/397
D713,714	S	*	9/2014	Kishida	D8/397
D735,569	S	*	8/2015	Reusing	D8/397
D738,714	S	*	9/2015	Kuhmichel	D8/397
2009/0189311	A1	*	7/2009	Quillin	A61Q 1/04 264/300

* cited by examiner

Primary Examiner — Cynthia Underwood

(74) *Attorney, Agent, or Firm* — Vincent G. LoTempio;
Kloss, Stenger & LoTempio; David Stephenson

(57) **CLAIM**

The ornamental design for a castle cap assembly, as shown and described.

DESCRIPTION

FIG. 1 is a top perspective exploded view of the castle cap assembly showing my new design reduced in scale;
 FIG. 2 is a bottom perspective exploded view thereof;
 FIG. 3 is a cross sectional view of the assembled castle cap taken generally along lines 3-3 in FIG. 13;
 FIG. 4 is a cross sectional view of the assembled castle cap taken generally along lines 4-4 in FIG. 13;
 FIG. 5 is a cross sectional view of the assembled castle cap taken generally along lines 5-5 in FIG. 13;
 FIG. 6 is a front elevational view of the double threaded slotted hex nut shown removed from the castle cap assembly with the rear elevational view being a mirror image thereof;
 FIG. 7 is a left side elevational view of the double threaded slotted hex nut shown removed from the castle cap assembly with the right side view being a mirror image thereof;
 FIG. 8 is a top plan view of the double threaded slotted hex nut shown removed from the castle cap assembly;
 FIG. 9 is a bottom plan view of the double threaded slotted hex nut shown removed from the castle cap assembly;
 FIG. 10 is a cross sectional view of the double threaded slotted hex nut shown removed from the castle cap assembly taken generally along lines 10-10 in FIG. 8;
 FIG. 11 is front elevational view of the castle cap assembly with the rear elevational view being a mirror image thereof;
 FIG. 12 is a left side view of the castle cap assembly with the right side being a mirror image thereof;
 FIG. 13 is a top plan view of the castle cap assembly;
 FIG. 14 is a bottom plan view of the castle cap assembly with the torsion pin shown removed;
 FIG. 15 is a cross sectional view of the castle cap taken generally along lines 15-15 in FIG. 14;
 FIG. 16 is the bottom plan view of the fully assembled castle cap assembly;
 FIG. 17 is a right side view of the torsion cotter pin shown enlarged in scale and removed from the castle cap assembly;
 FIG. 18 is a left side view thereof;
 FIG. 19 is a top plan view thereof
 FIG. 20 is a bottom plan view of the torsion cotter pin thereof;
 FIG. 21 is a top perspective view of the torsion cotter pin thereof;
 FIG. 22 is a bottom perspective view of the torsion cotter pin thereof;
 FIG. 23 is a front view of the torsion cotter pin thereof; and,
 FIG. 24 is a rear view of the torsion cotter pin shown thereof.

1 Claim, 4 Drawing Sheets

FIG. 1

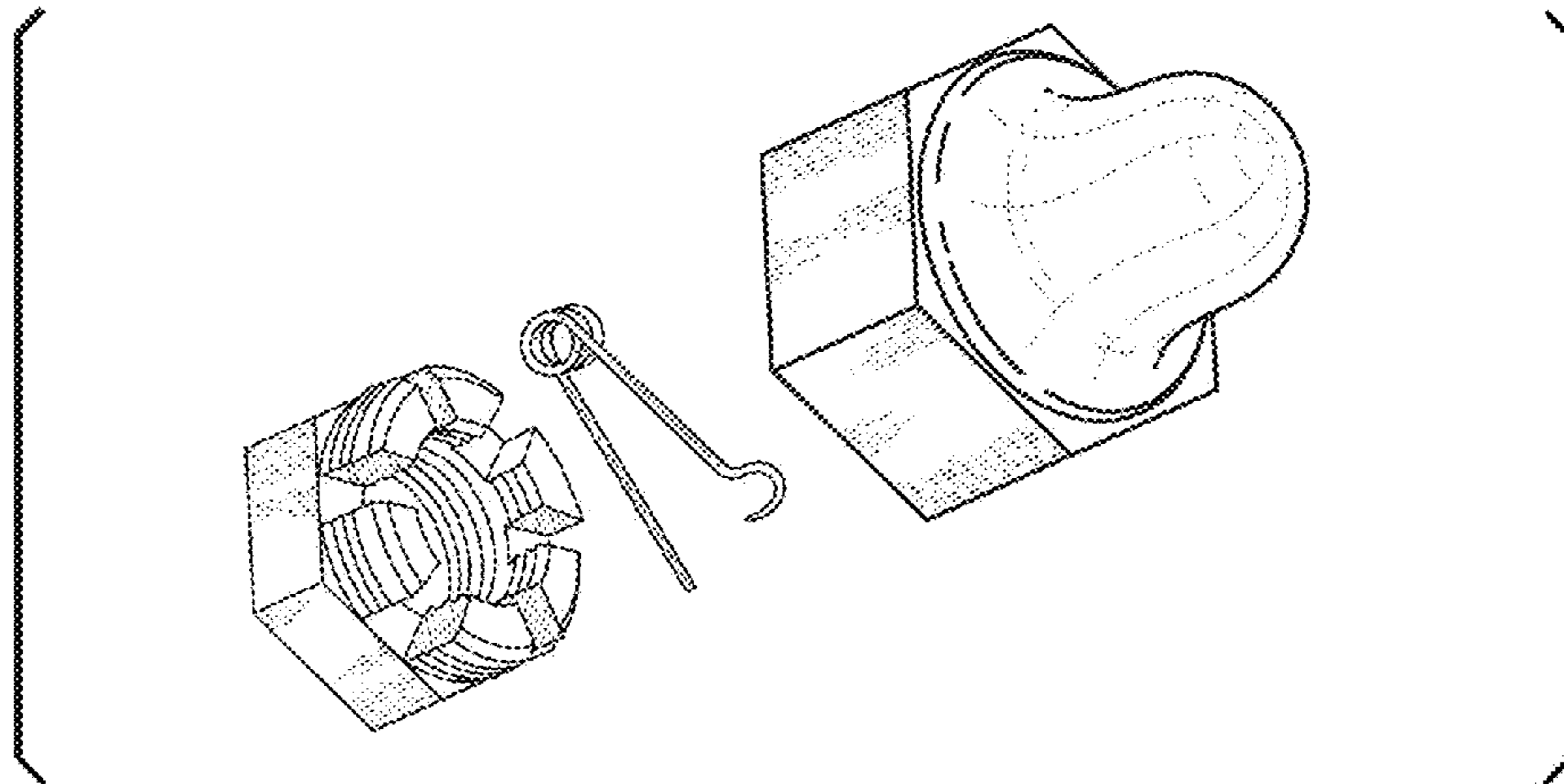

FIG. 2

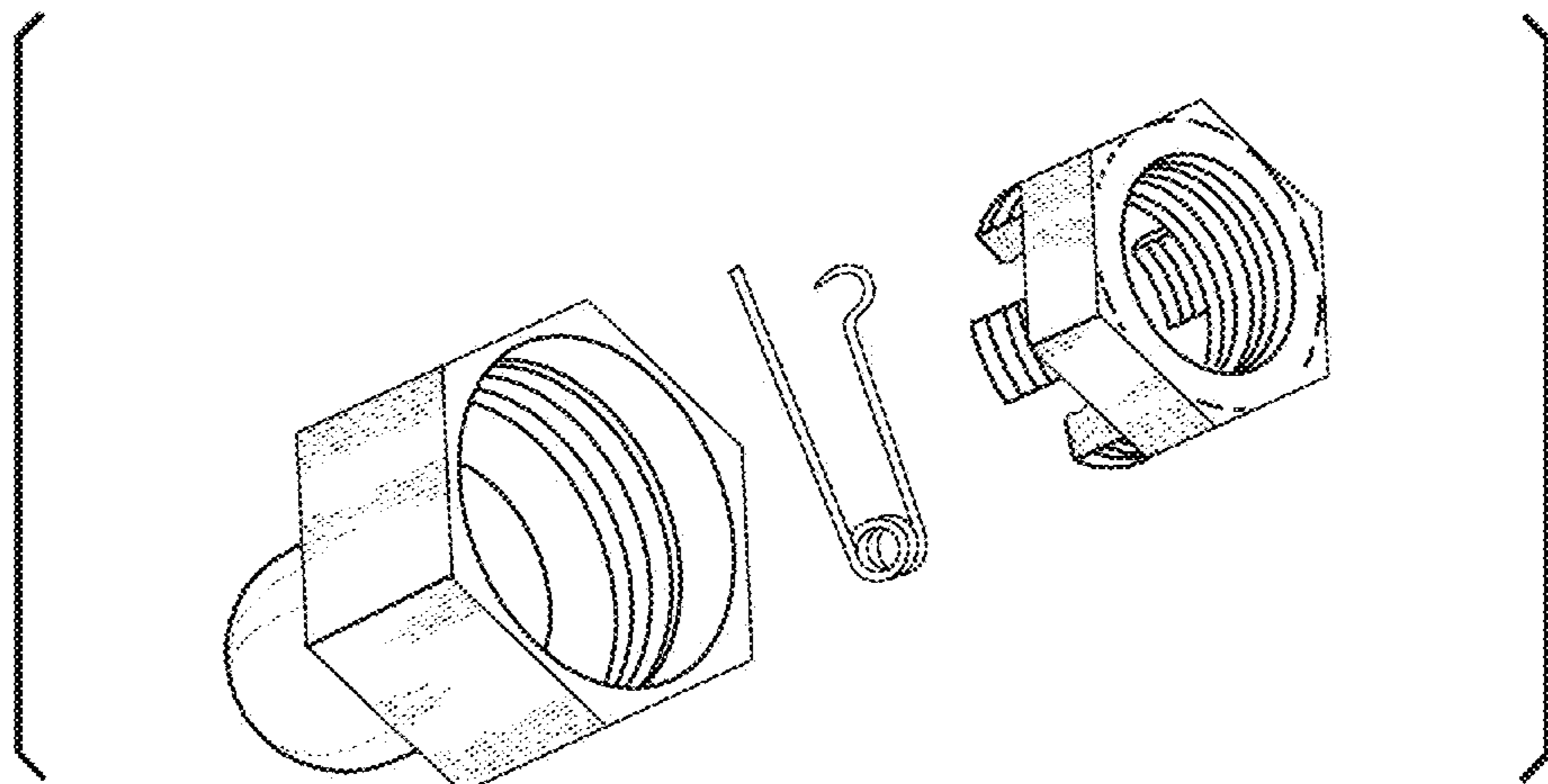

FIG. 3

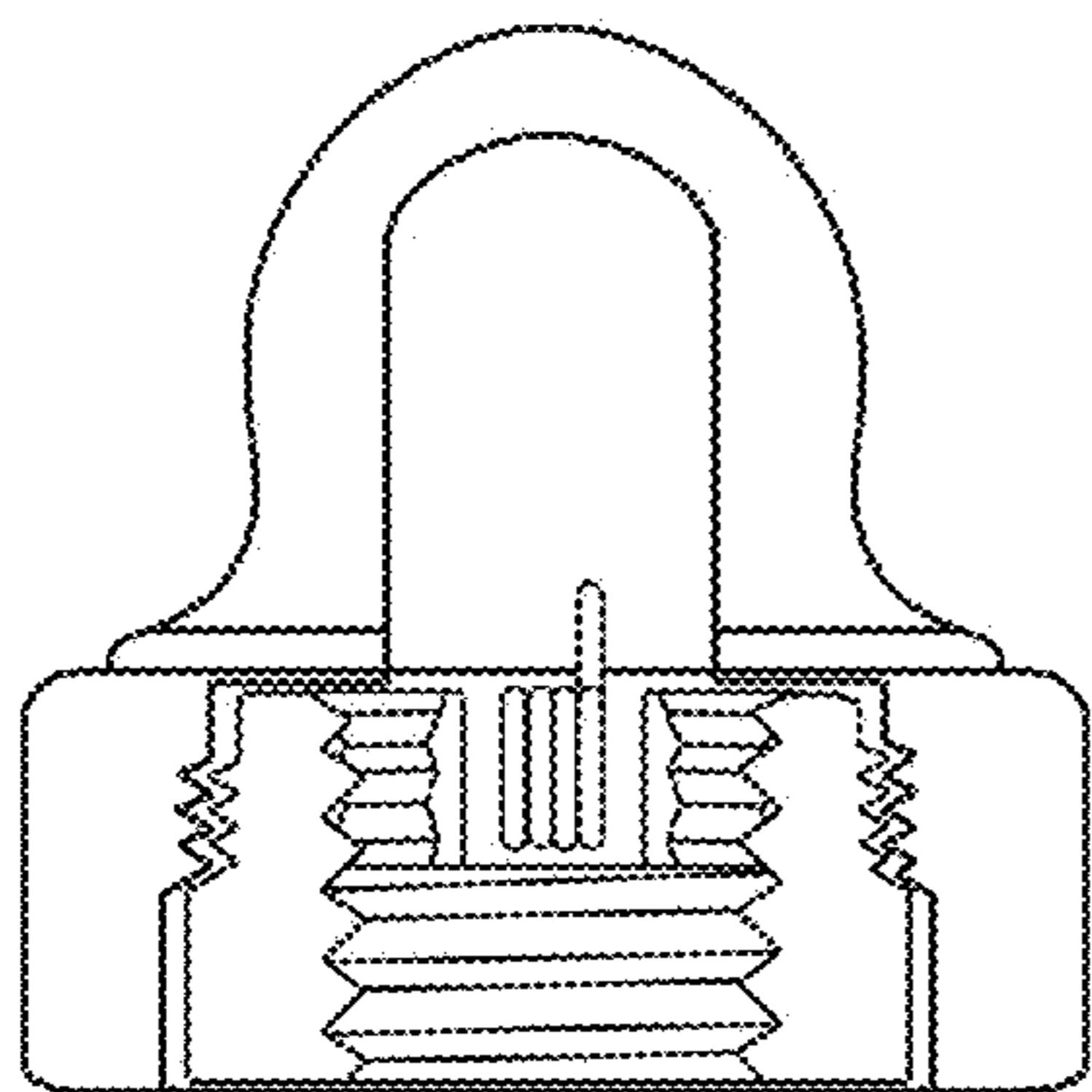

FIG. 4

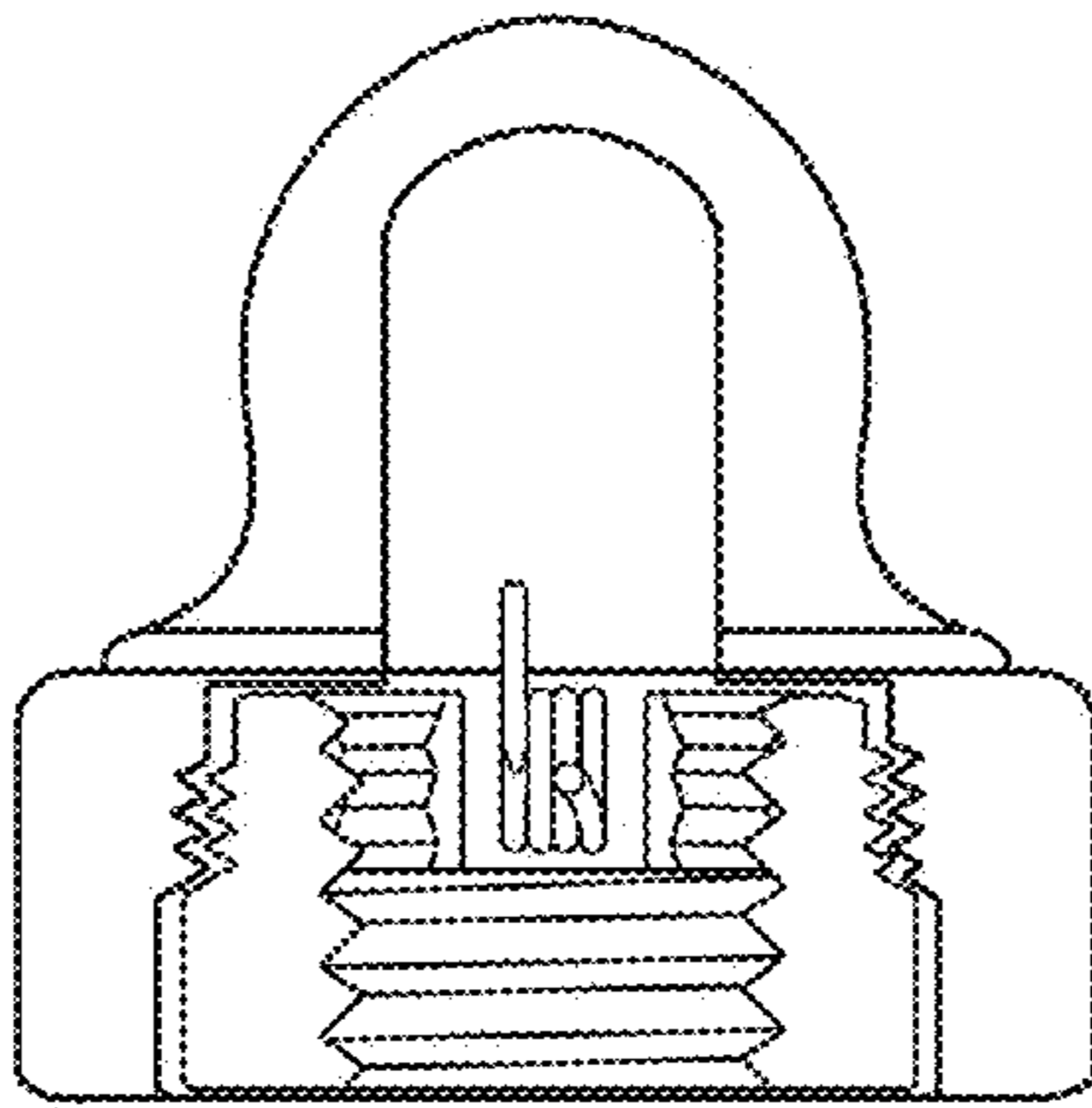

FIG. 5

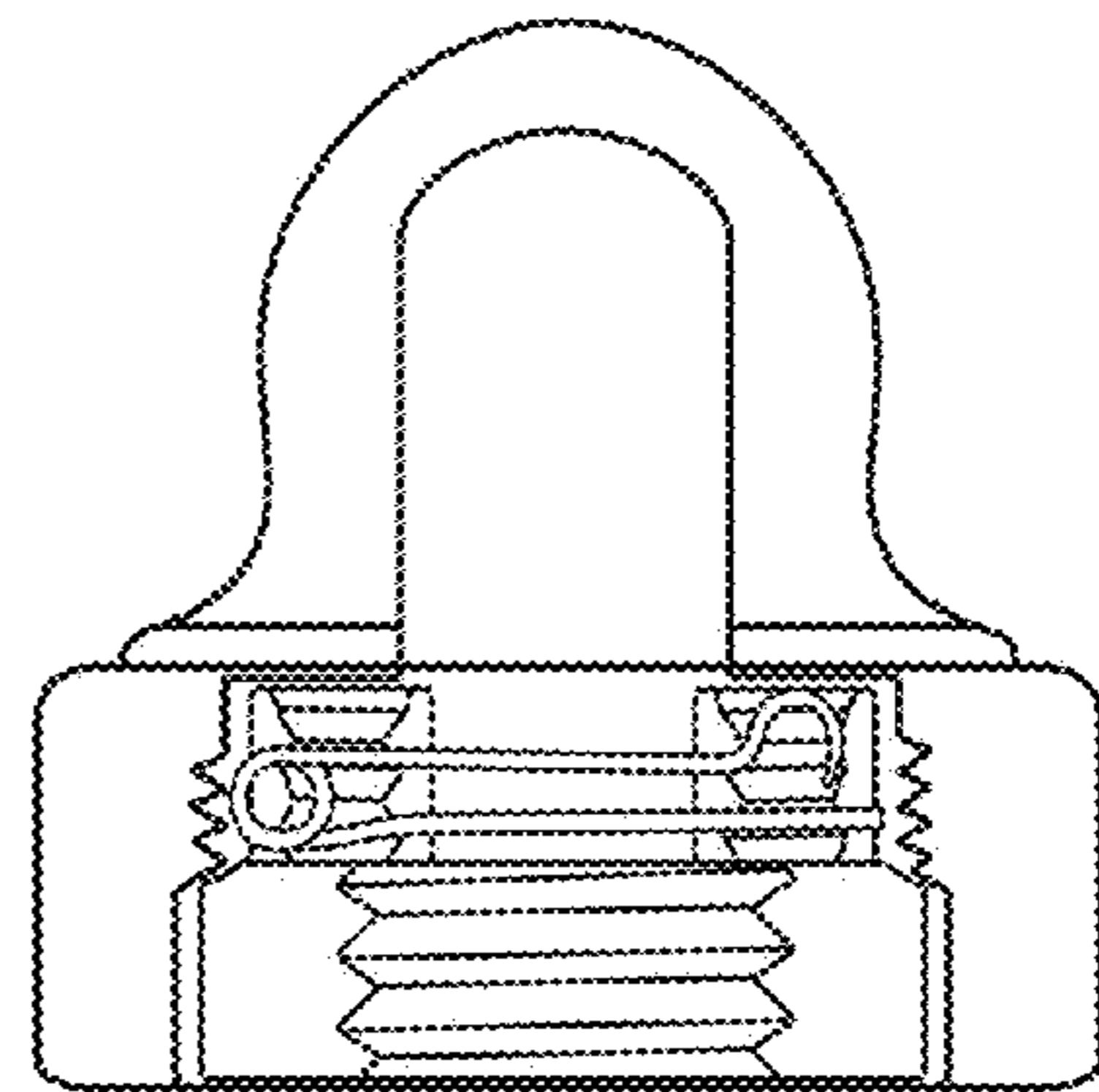

FIG. 6

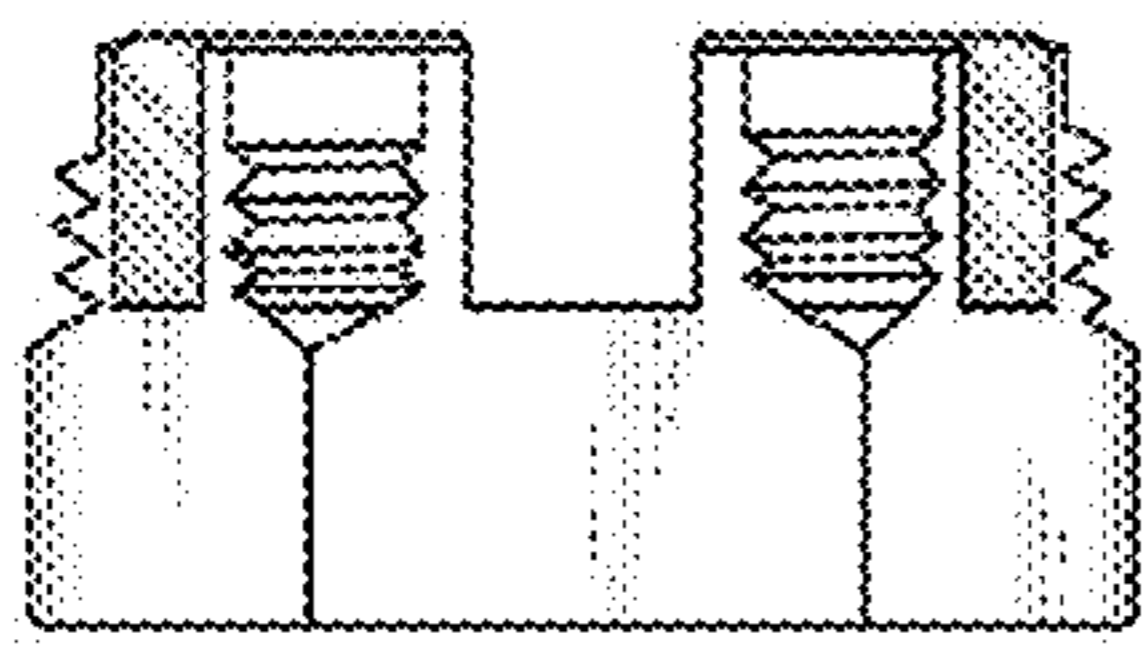

FIG. 7

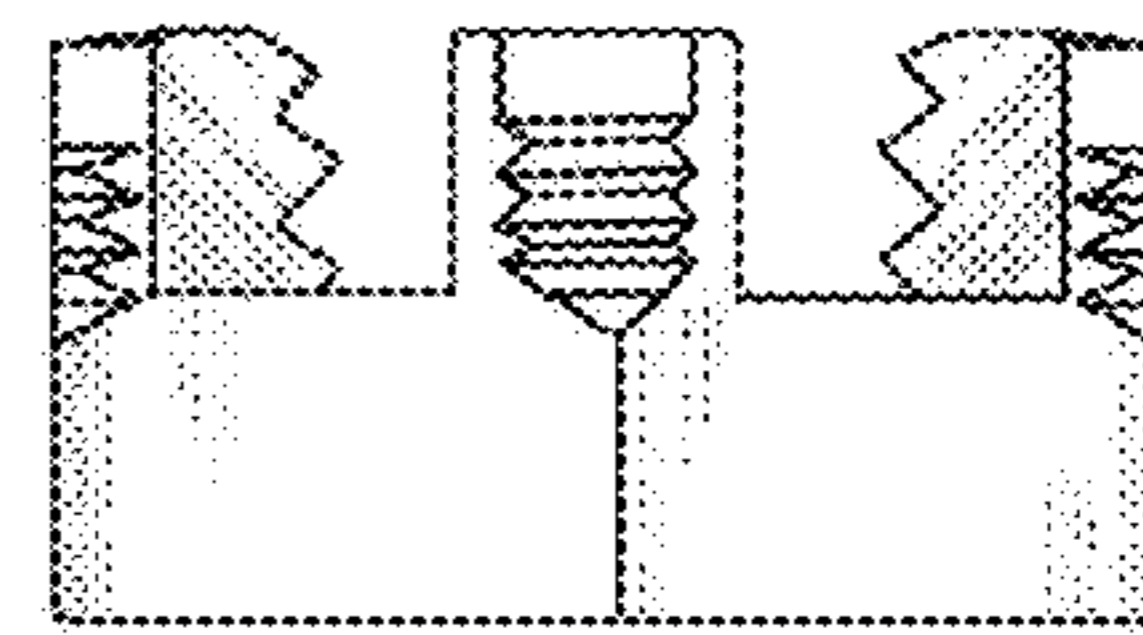

FIG. 8

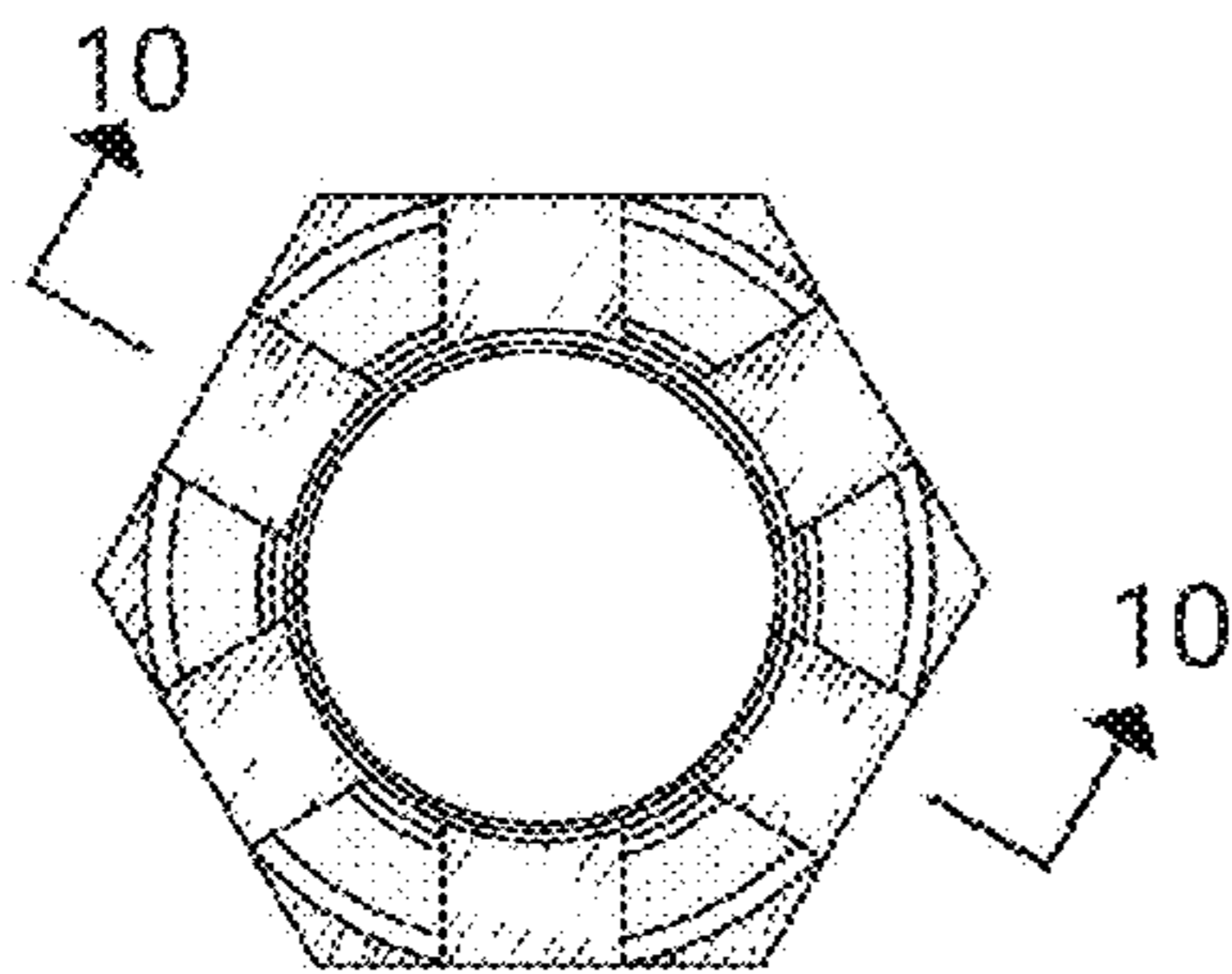

FIG. 9

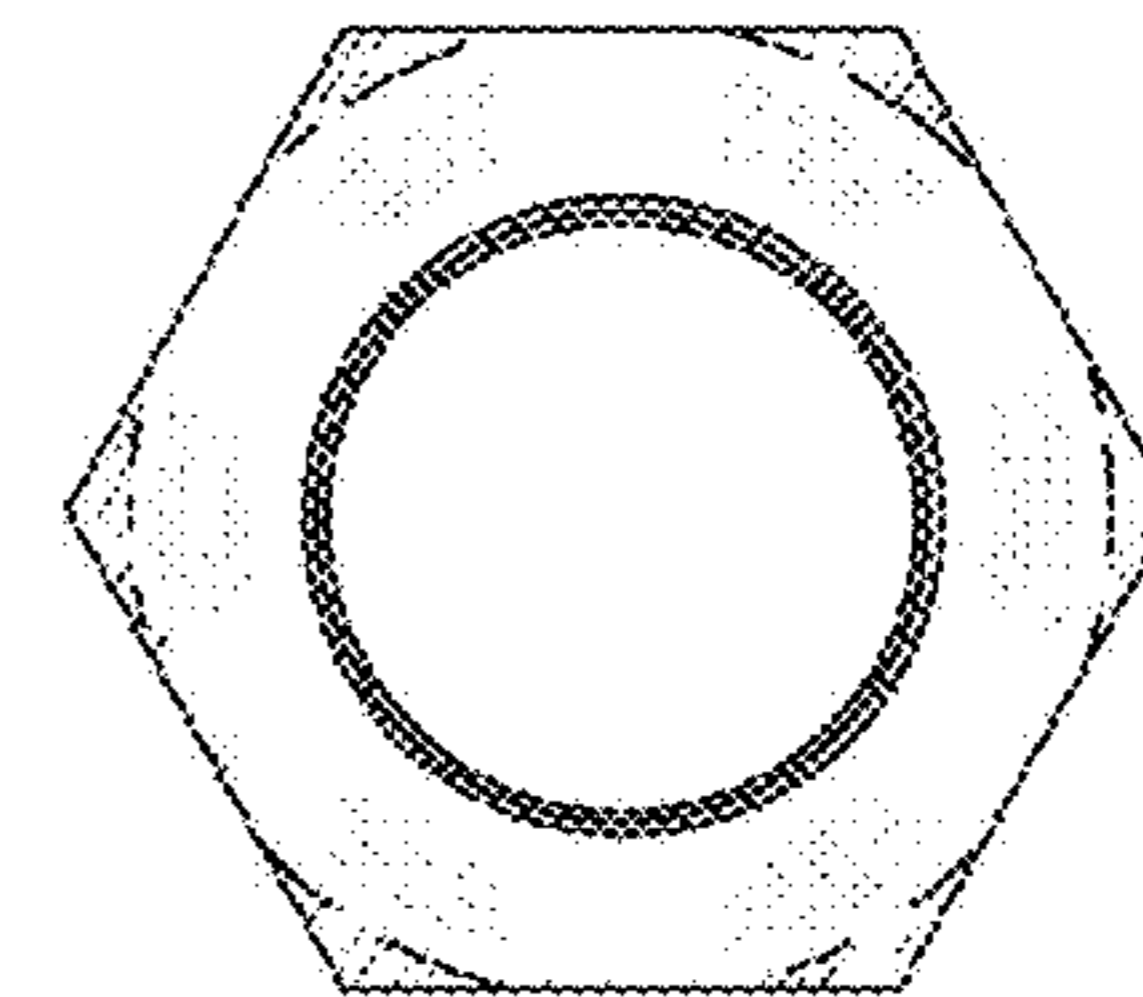

FIG. 10

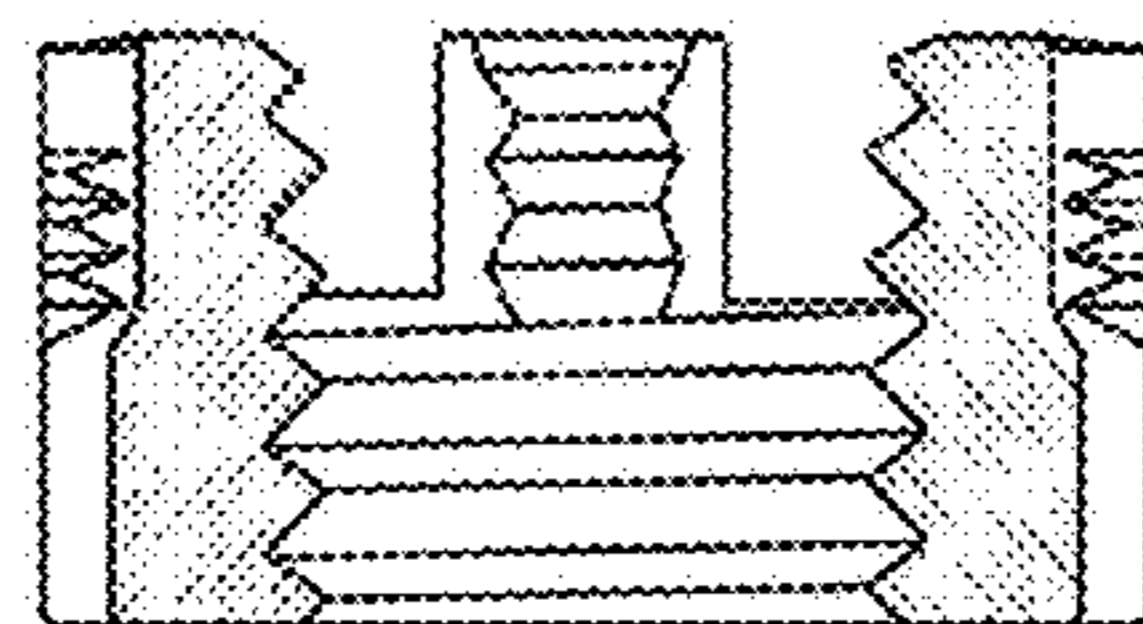

FIG. 11

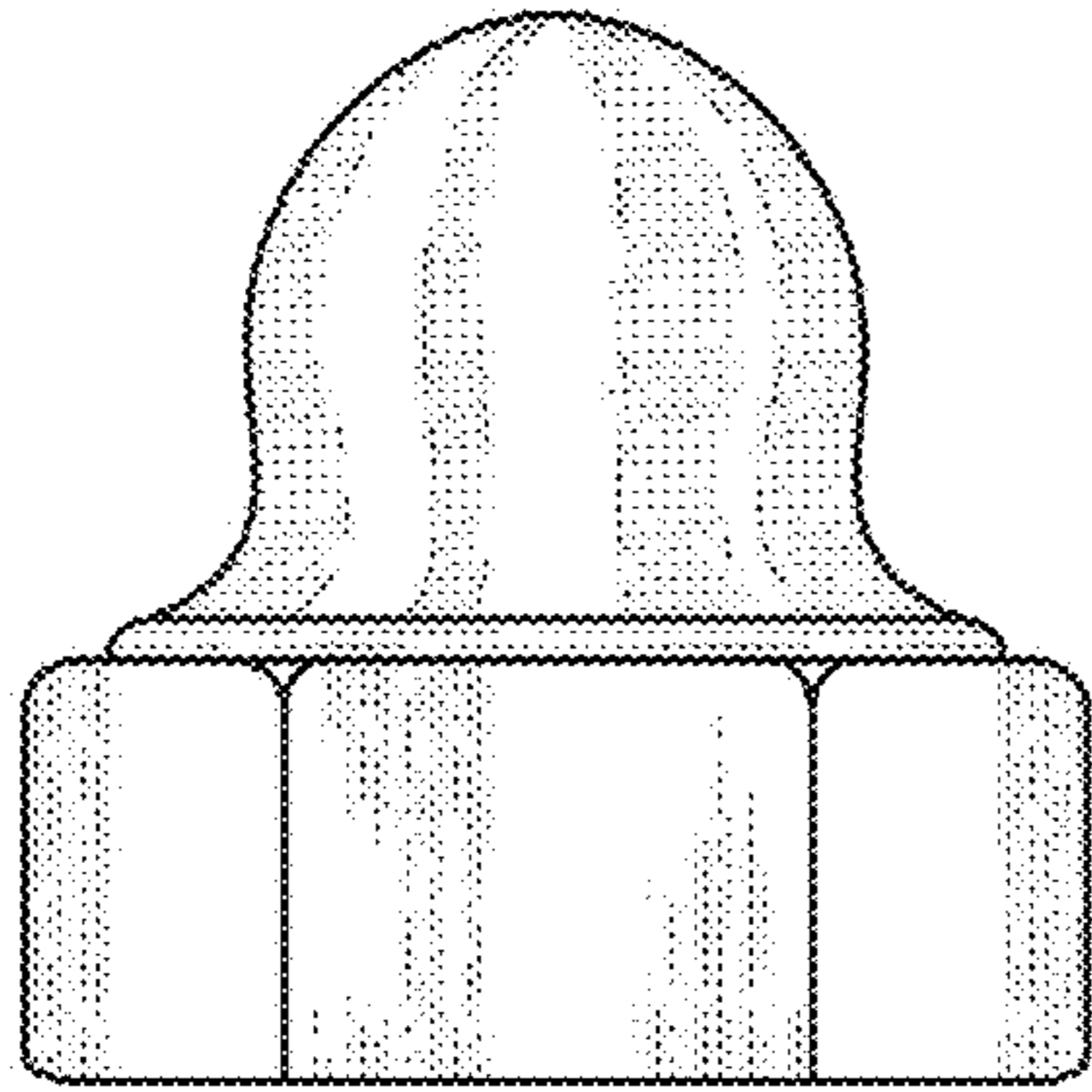

FIG. 12

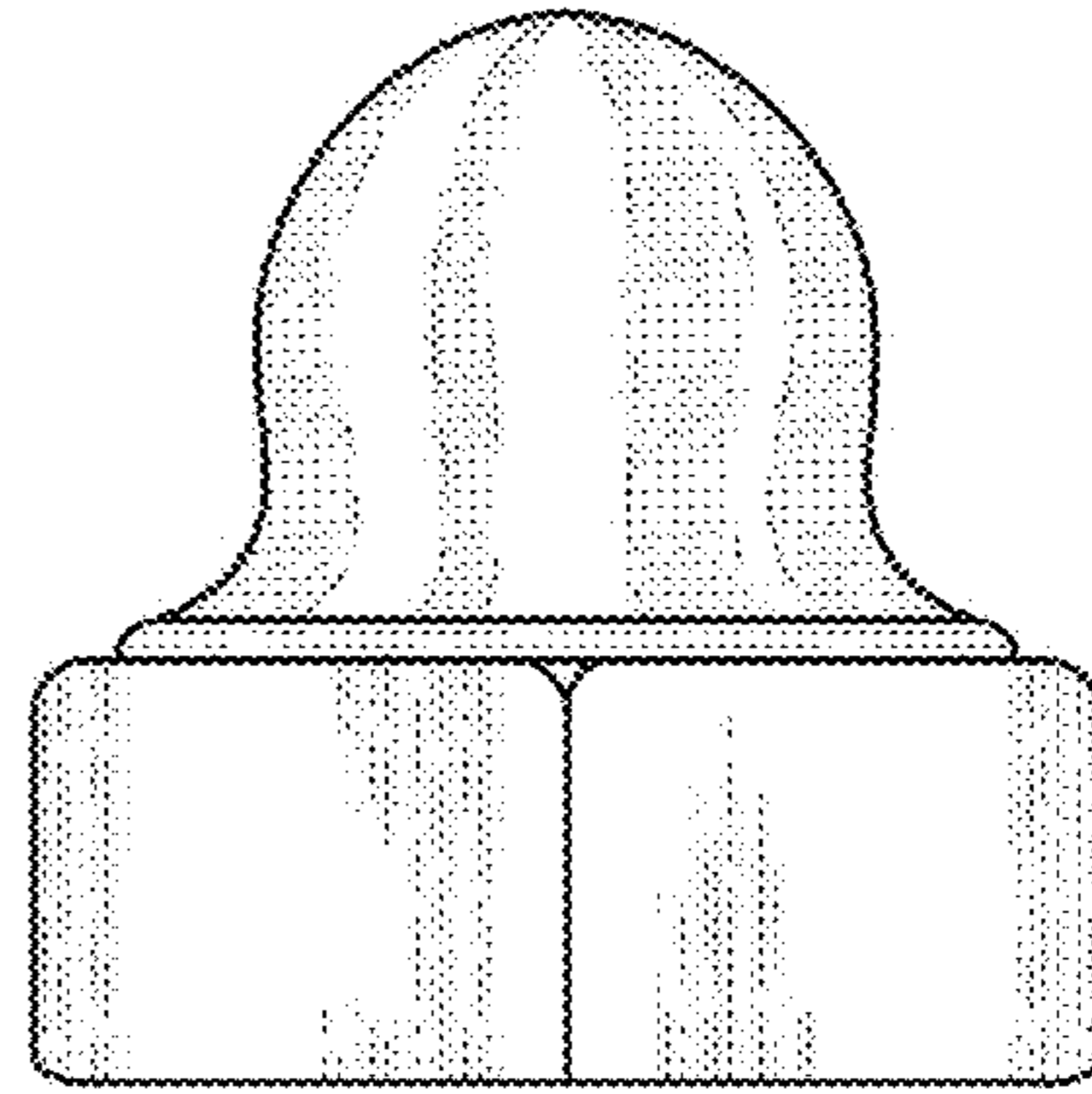

FIG. 13

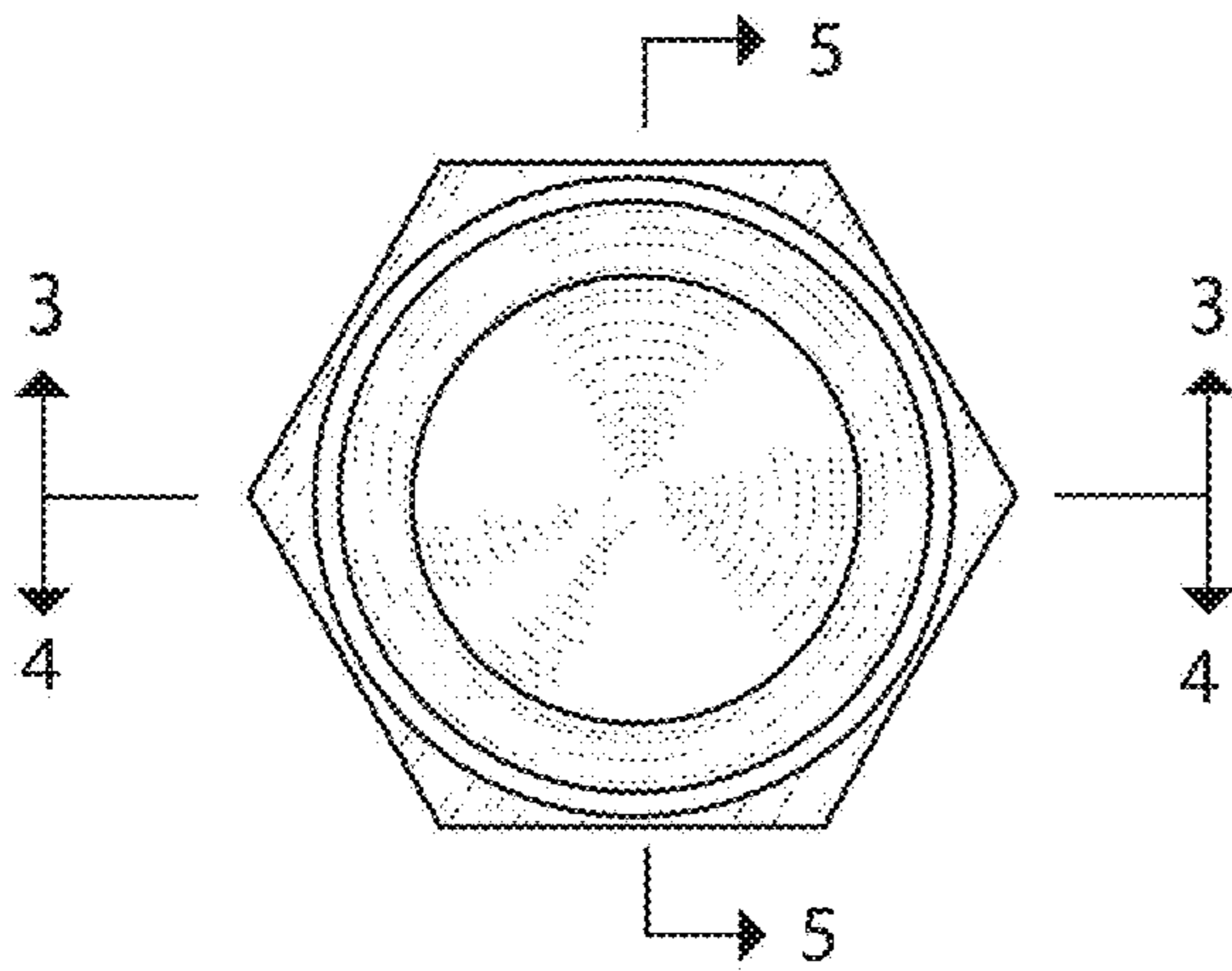

FIG. 14

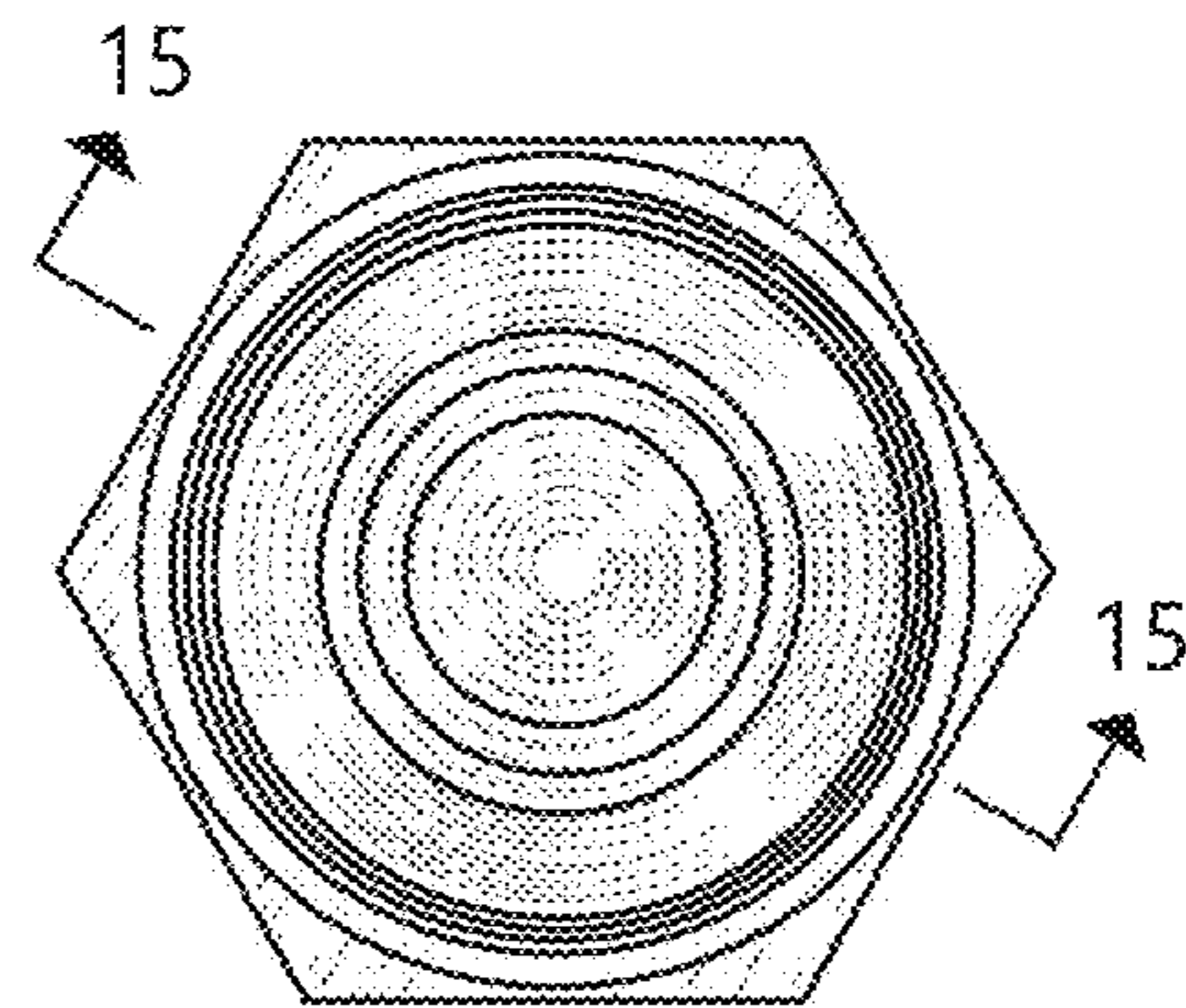

FIG. 15

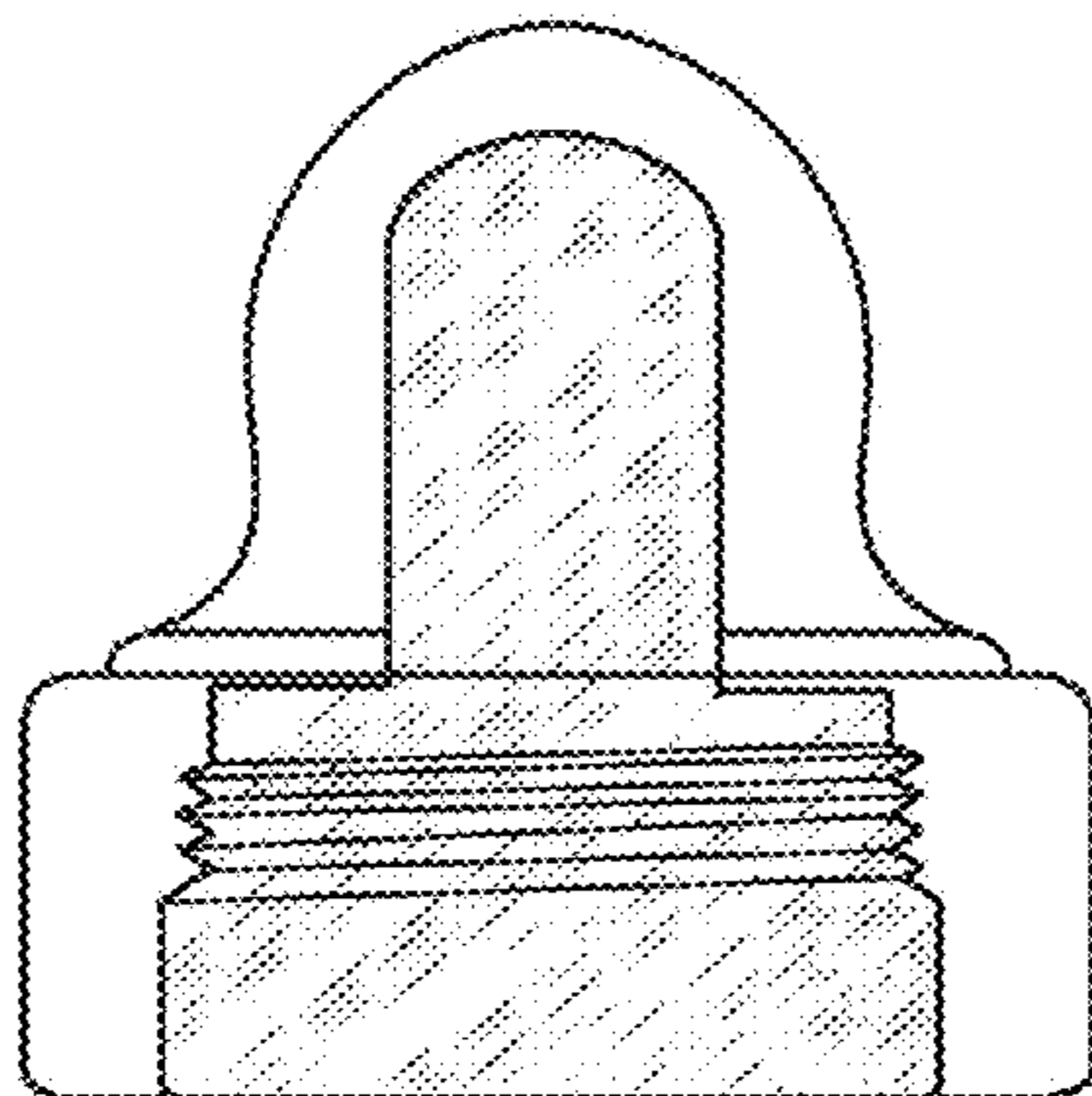

FIG. 16

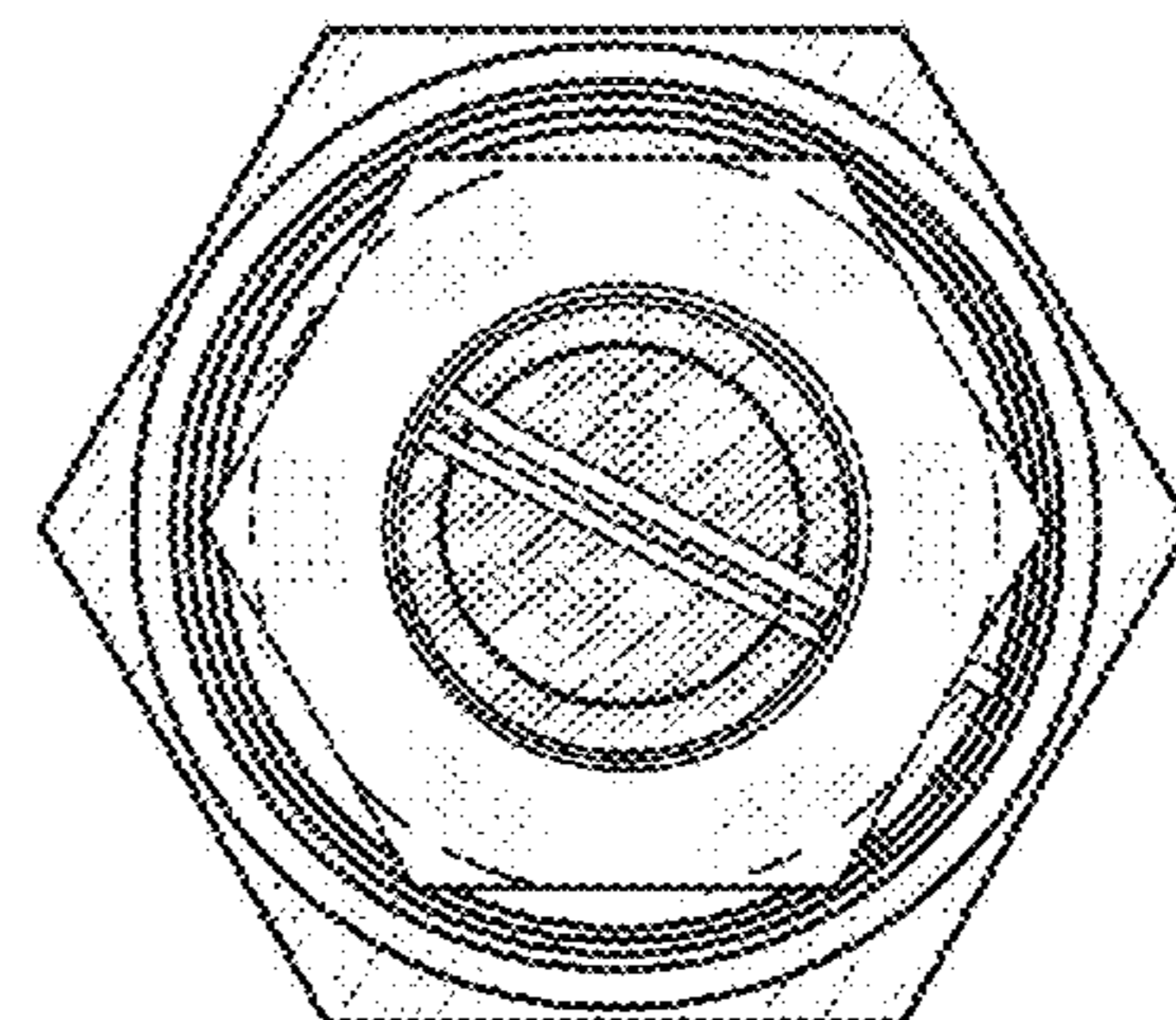

FIG. 17

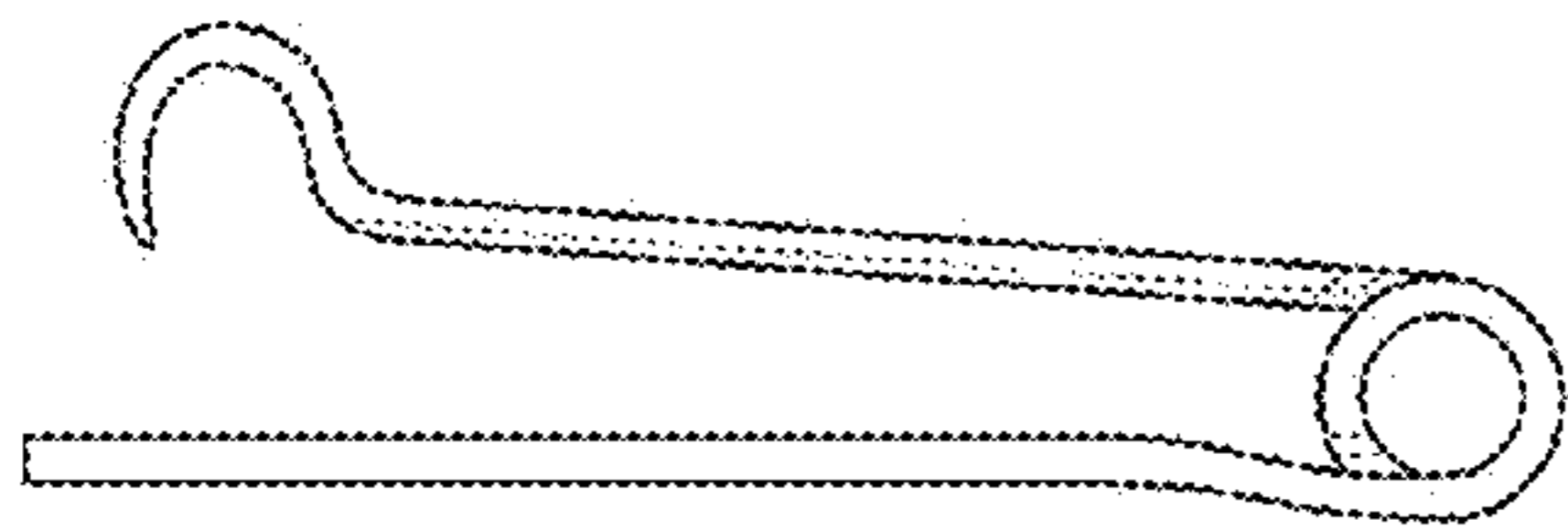

FIG. 18

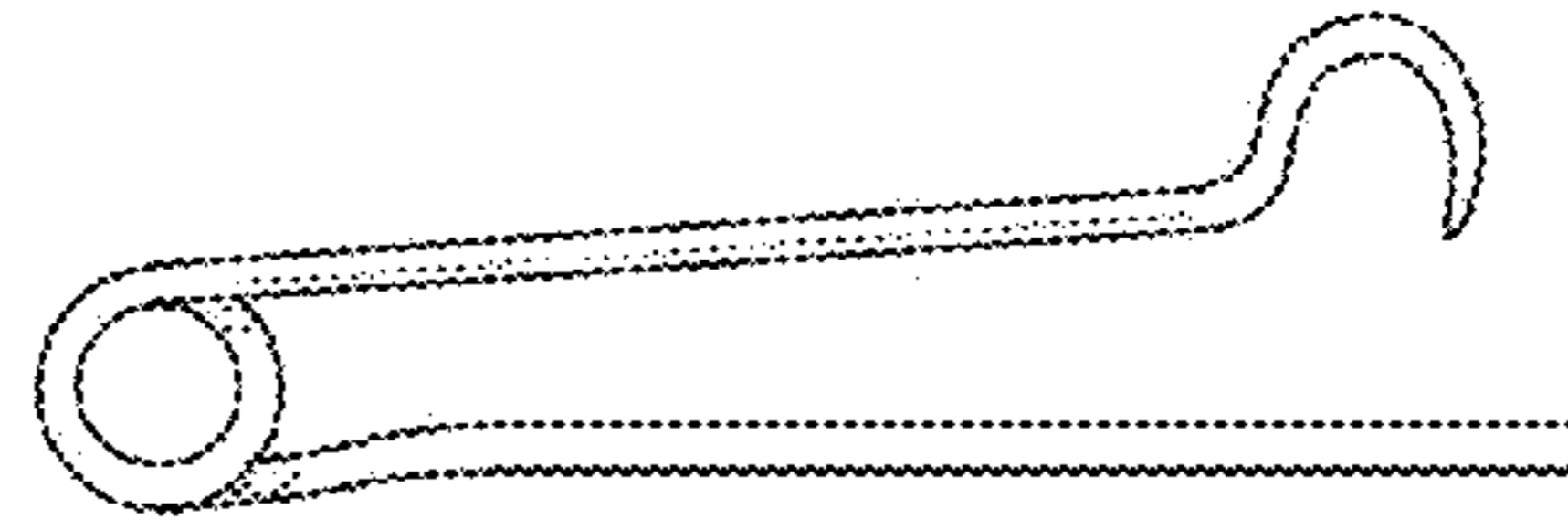

FIG. 19

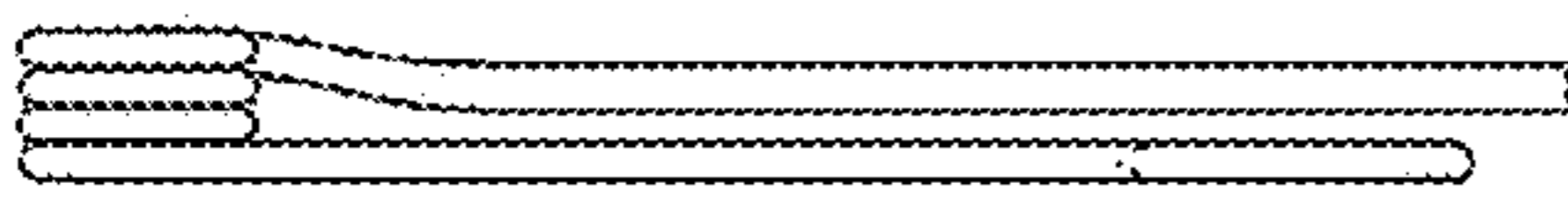

FIG. 20

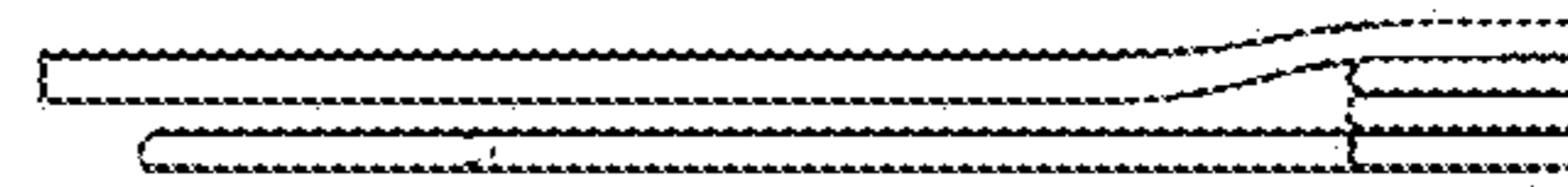

FIG. 21

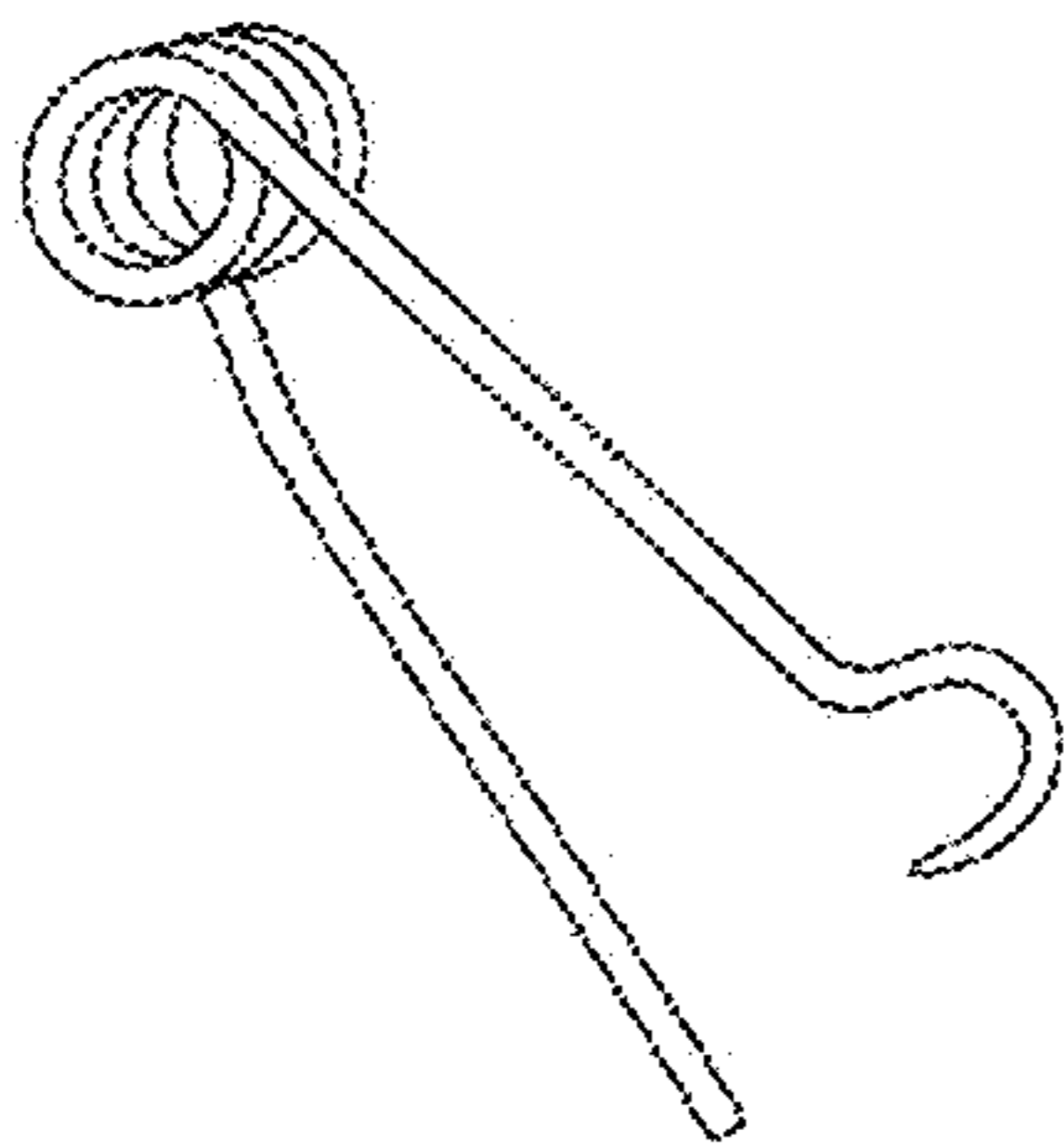

FIG. 22

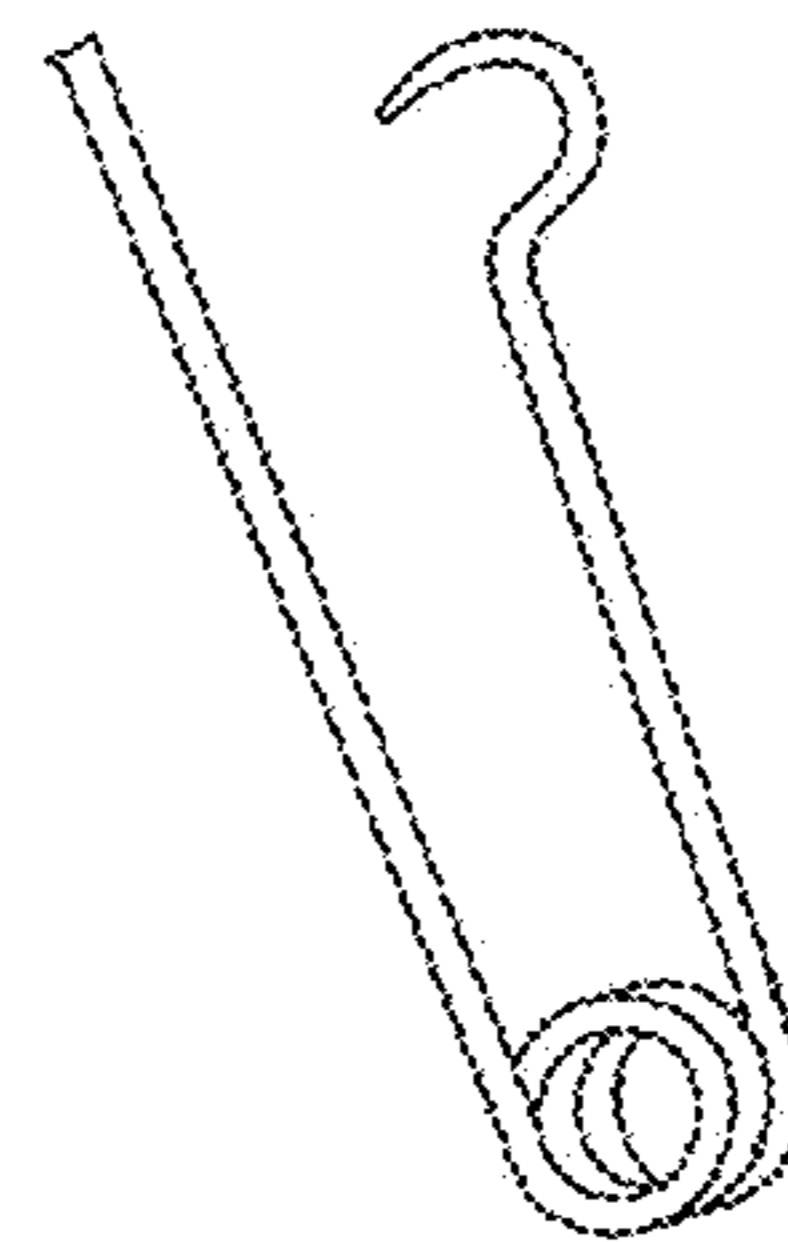

FIG. 23



FIG. 24

