



US00D748405S

(12) **United States Design Patent**  
**Sethapun et al.**

(10) **Patent No.:** **US D748,405 S**

(45) **Date of Patent:** **\*\* Feb. 2, 2016**

(54) **AIRCRAFT PASSENGER SEAT**

(71) Applicant: **Gulfstream Aerospace Corporation,**  
Savannah, GA (US)

(72) Inventors: **Kevin Sethapun,** Savannah, GA (US);  
**Andrew Fulford,** Northville, MI (US);  
**Aram Kasparian,** Savannah, GA (US)

(73) Assignee: **Gulfstream Aerospace Corporation,**  
Savannah, GA (US)

(\*\*) Term: **14 Years**

(21) Appl. No.: **29/506,157**

(22) Filed: **Oct. 14, 2014**

(51) **LOC (10) Cl.** ..... **06-01**

(52) **U.S. Cl.**  
USPC ..... **D6/356**

(58) **Field of Classification Search**  
USPC ..... D6/334–336, 356, 364, 365, 367, 368,  
D6/374, 381, 716, 716.1, 716.2, 716.3,  
D6/716.4

CPC ..... B60N 2/22; B60N 2/2878; B60N 2/34;  
B64D 11/06; B64D 11/0601; A47C 1/032  
See application file for complete search history.

(56) **References Cited**

**U.S. PATENT DOCUMENTS**

D269,652 S \* 7/1983 McKean ..... D6/356  
D273,157 S \* 3/1984 Staub ..... D6/356  
D405,275 S \* 2/1999 Dryburgh ..... D6/335  
D411,922 S \* 7/1999 Granados ..... D6/356

6,742,842 B2 \* 6/2004 Dowty ..... B64D 11/06  
297/354.13  
D493,294 S \* 7/2004 Newson ..... D6/356  
D577,503 S \* 9/2008 Priestman ..... D6/356  
D592,412 S \* 5/2009 Suge ..... D6/356  
D703,964 S \* 5/2014 Gagnon ..... D6/356  
D731,193 S \* 6/2015 Zuber ..... D6/356

\* cited by examiner

*Primary Examiner* — Mimoso De

(74) *Attorney, Agent, or Firm* — Ingrassia, Fisher & Lorenz  
PC

(57) **CLAIM**

The ornamental design for an aircraft passenger seat, as shown and described.

**DESCRIPTION**

FIG. 1 is a front perspective view of an aircraft passenger seat showing our new design;

FIG. 2 is a front perspective view thereof;

FIG. 3 is a back perspective view thereof;

FIG. 4 is a front view thereof;

FIG. 5 is a back view thereof;

FIG. 6 is a top view thereof;

FIG. 7 is a bottom view thereof;

FIG. 8 is a first side view thereof; and,

FIG. 9 is a second side view thereof.

The even length broken lines illustrate structure and environment that form no part of the claimed design. The single long dash and single short dot broken lines represent a break line illustrating bounds of the claimed design and forming part thereof.

**1 Claim, 6 Drawing Sheets**

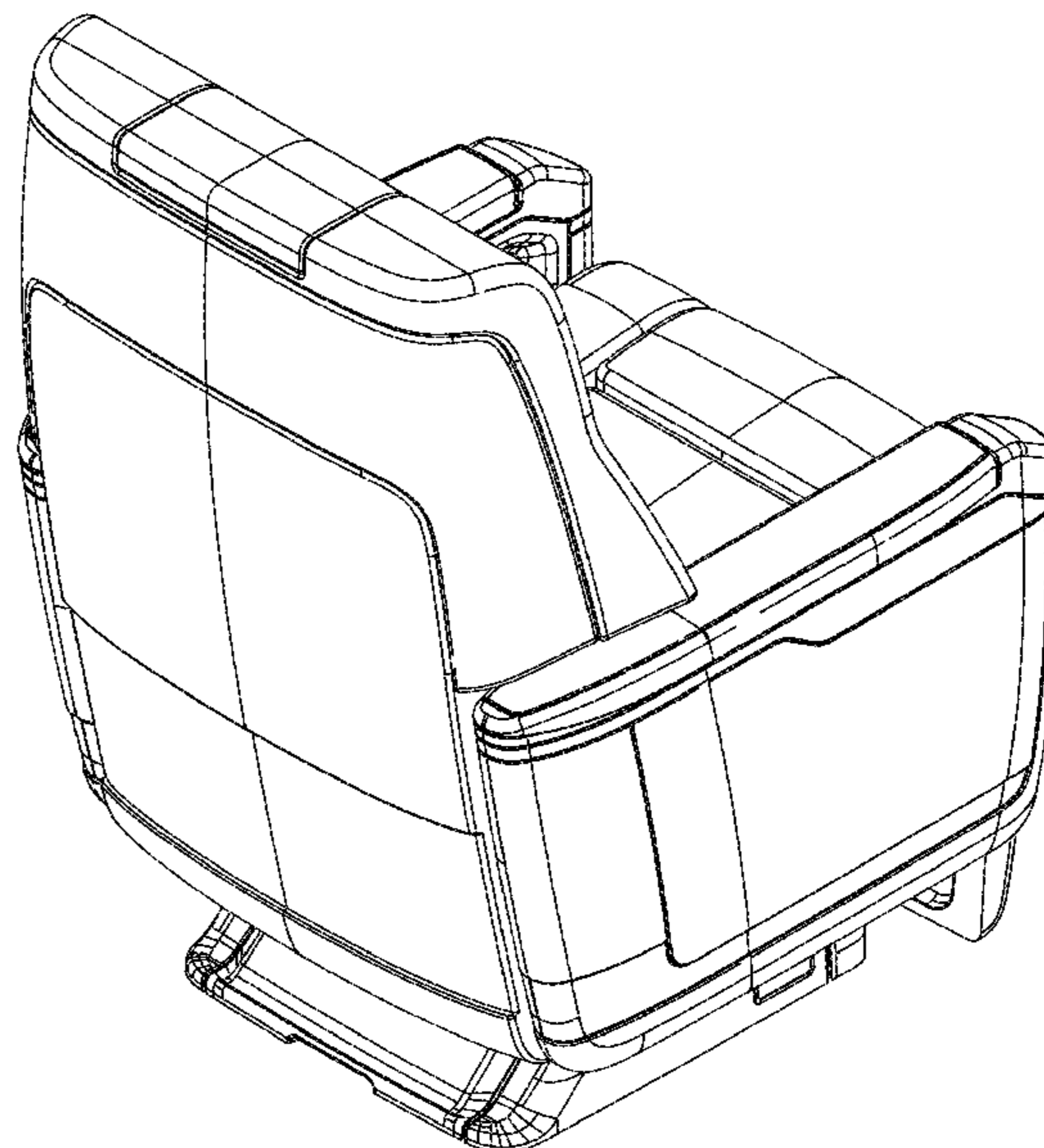
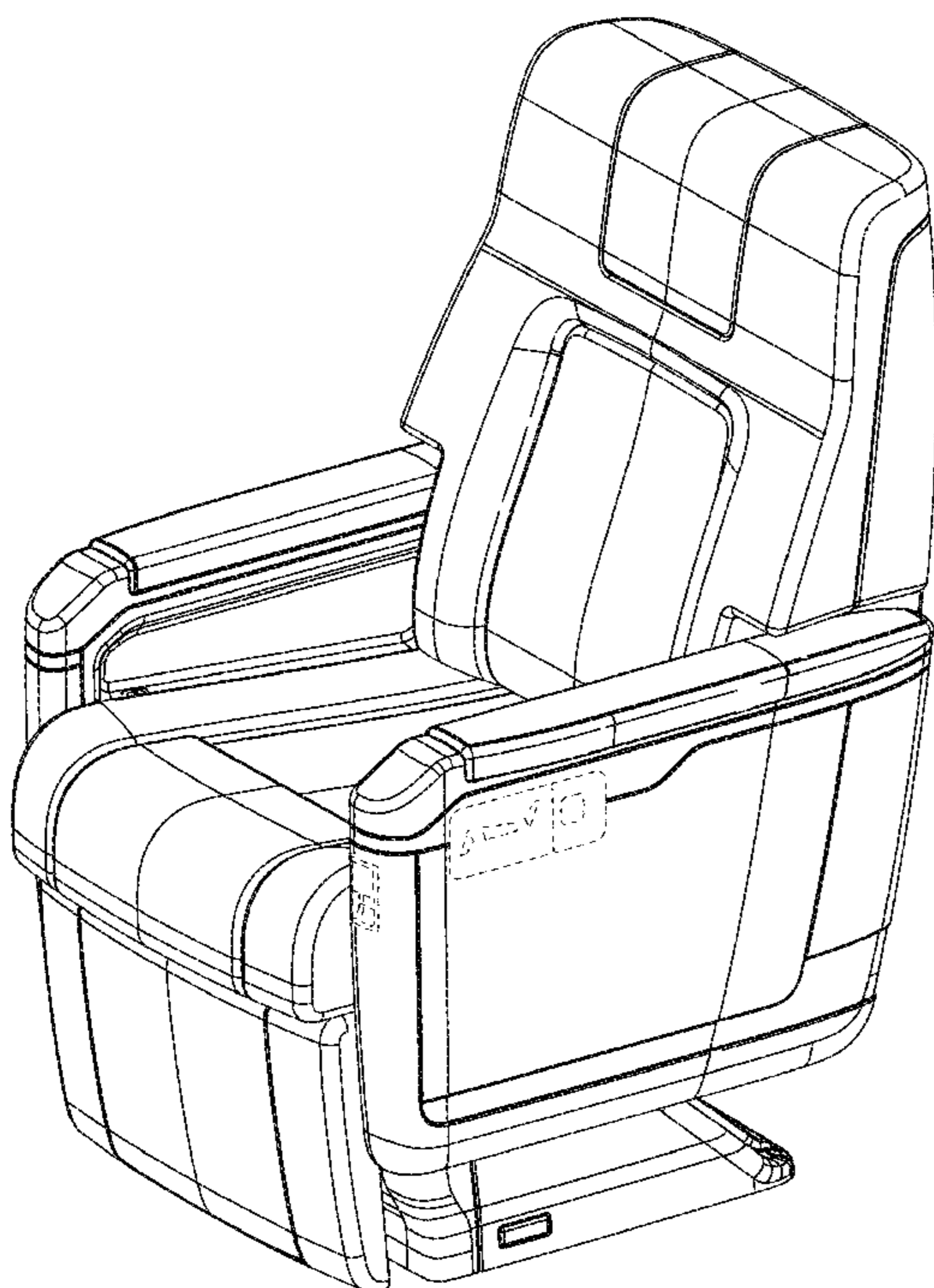

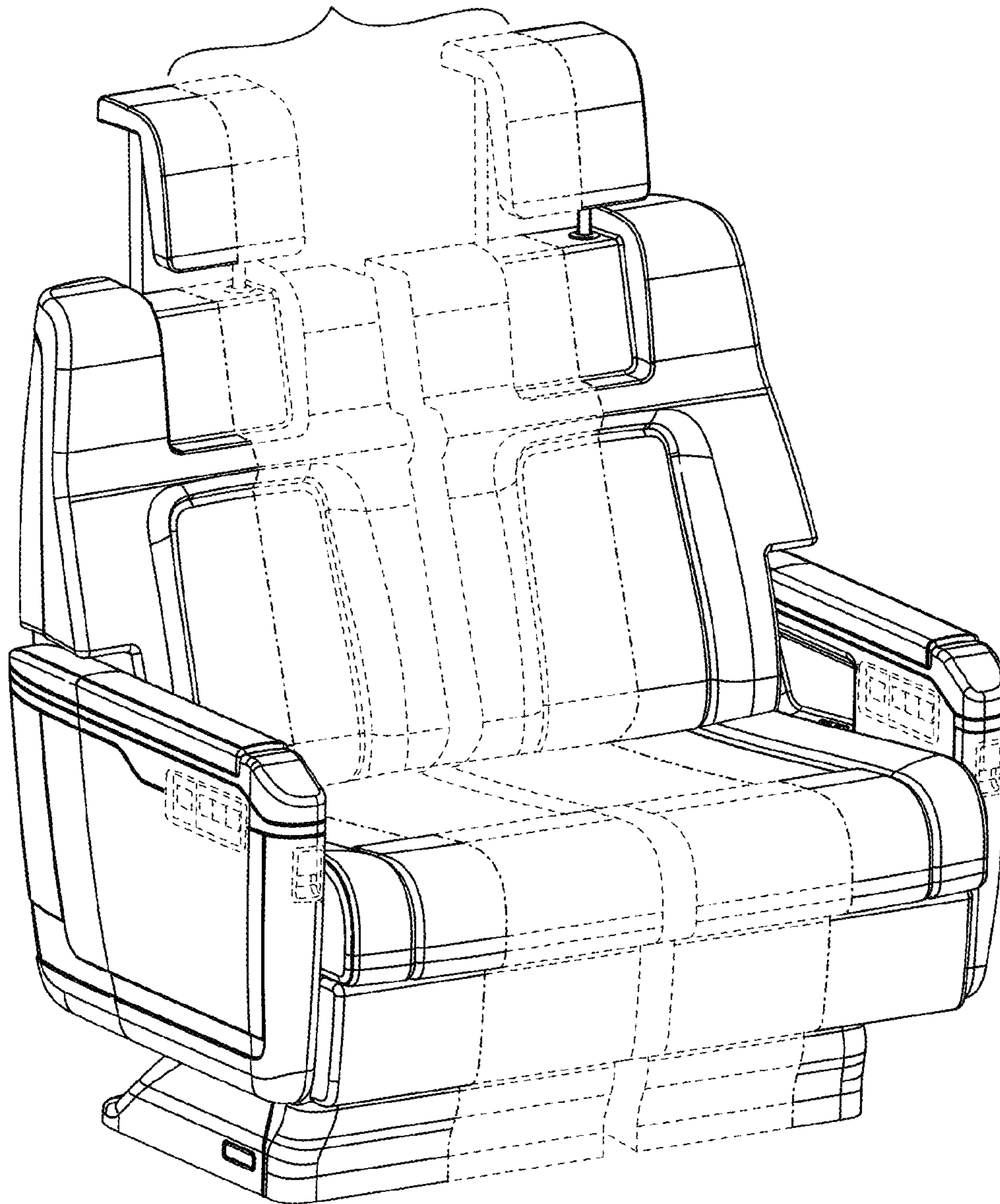

FIG. 1



FIG. 2

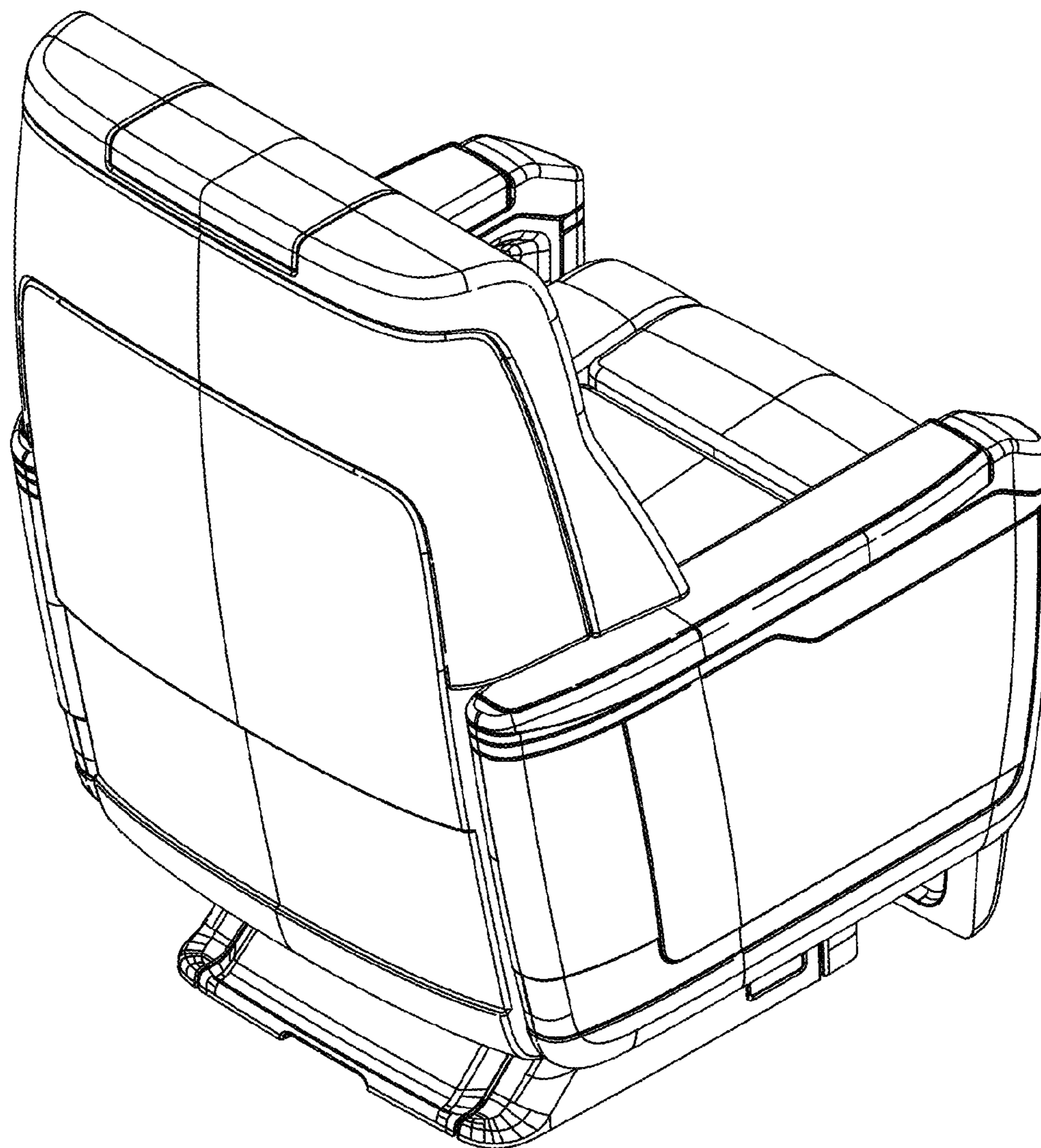

FIG. 3

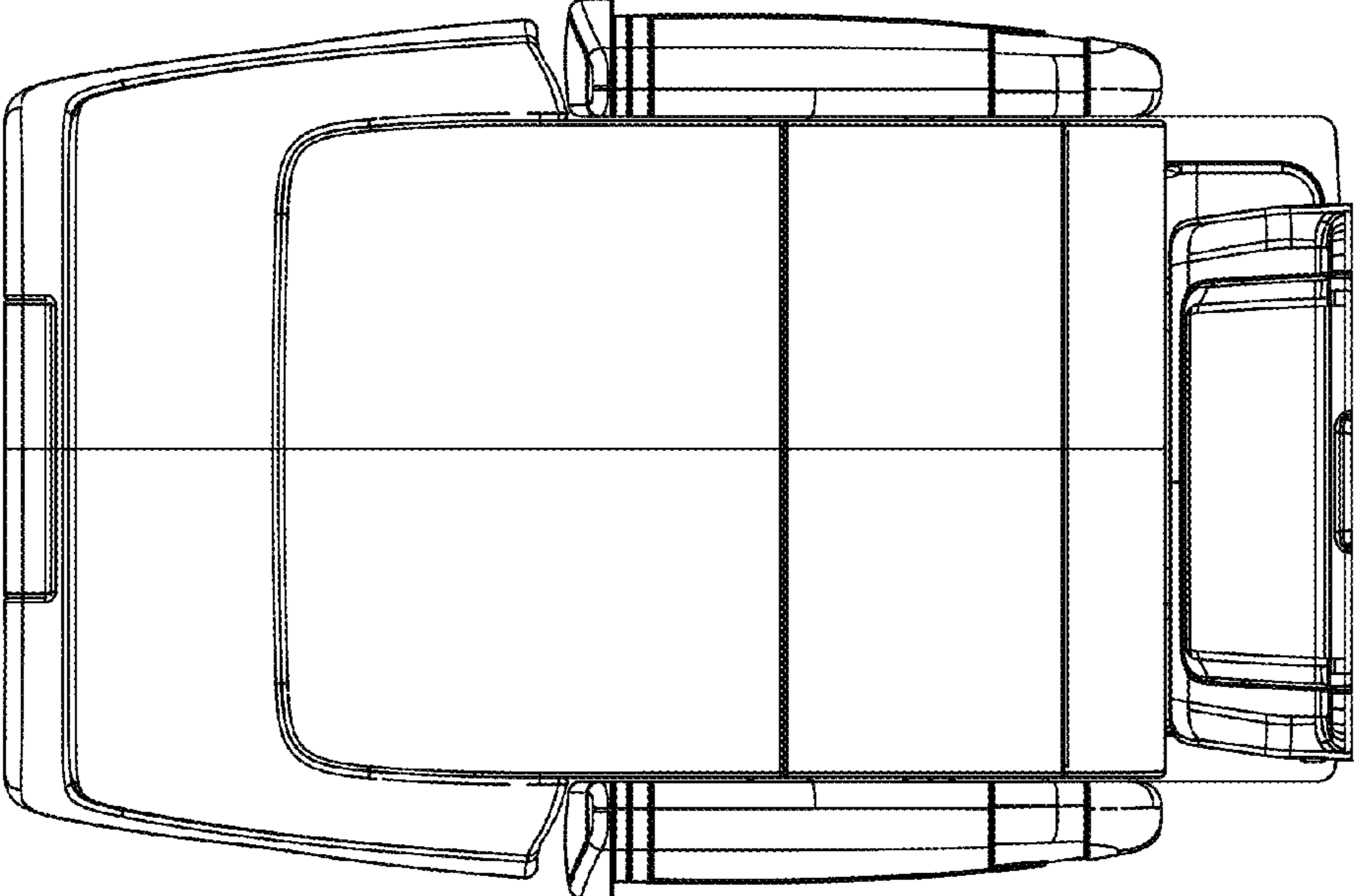

FIG. 5

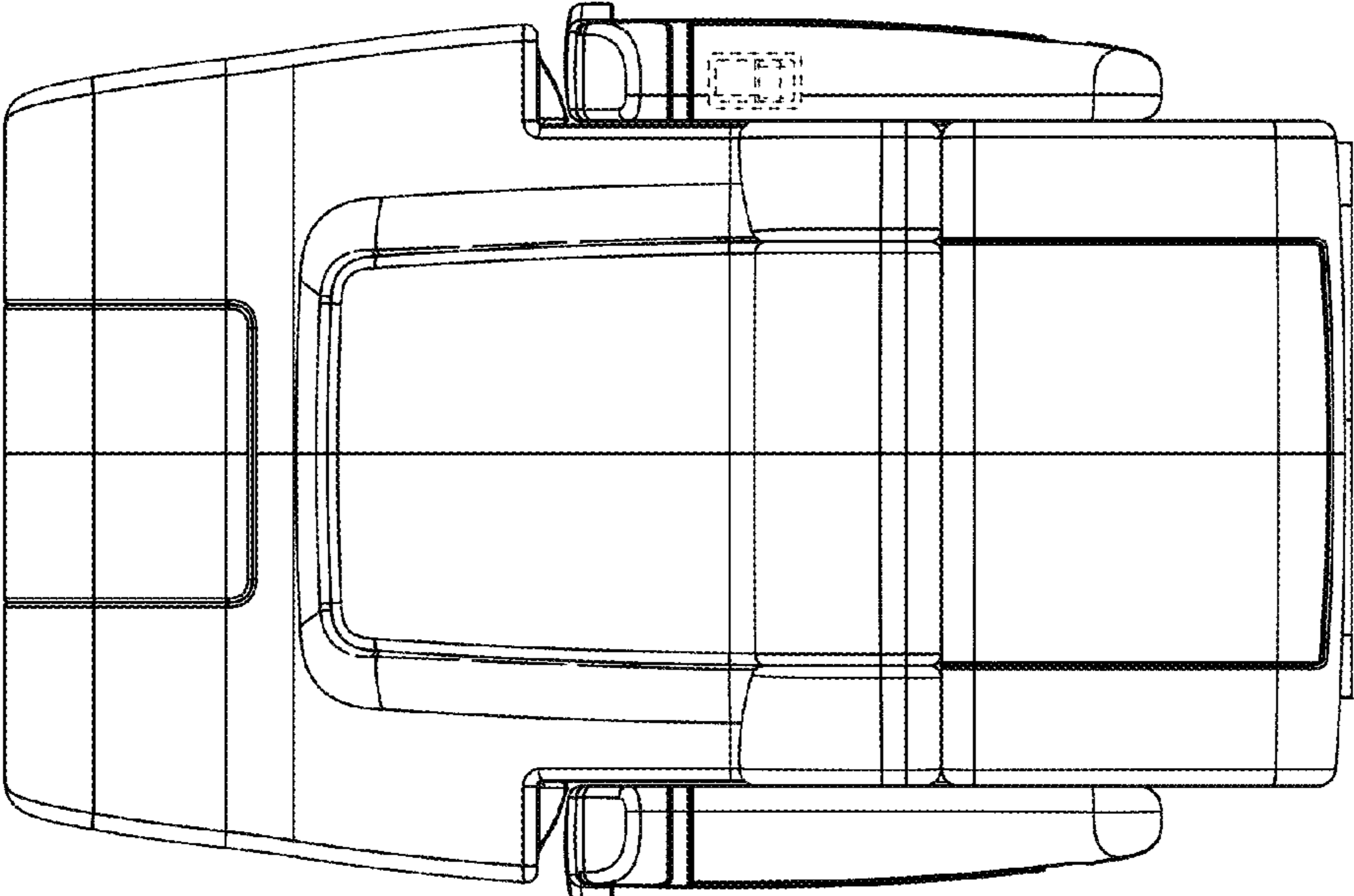

FIG. 4

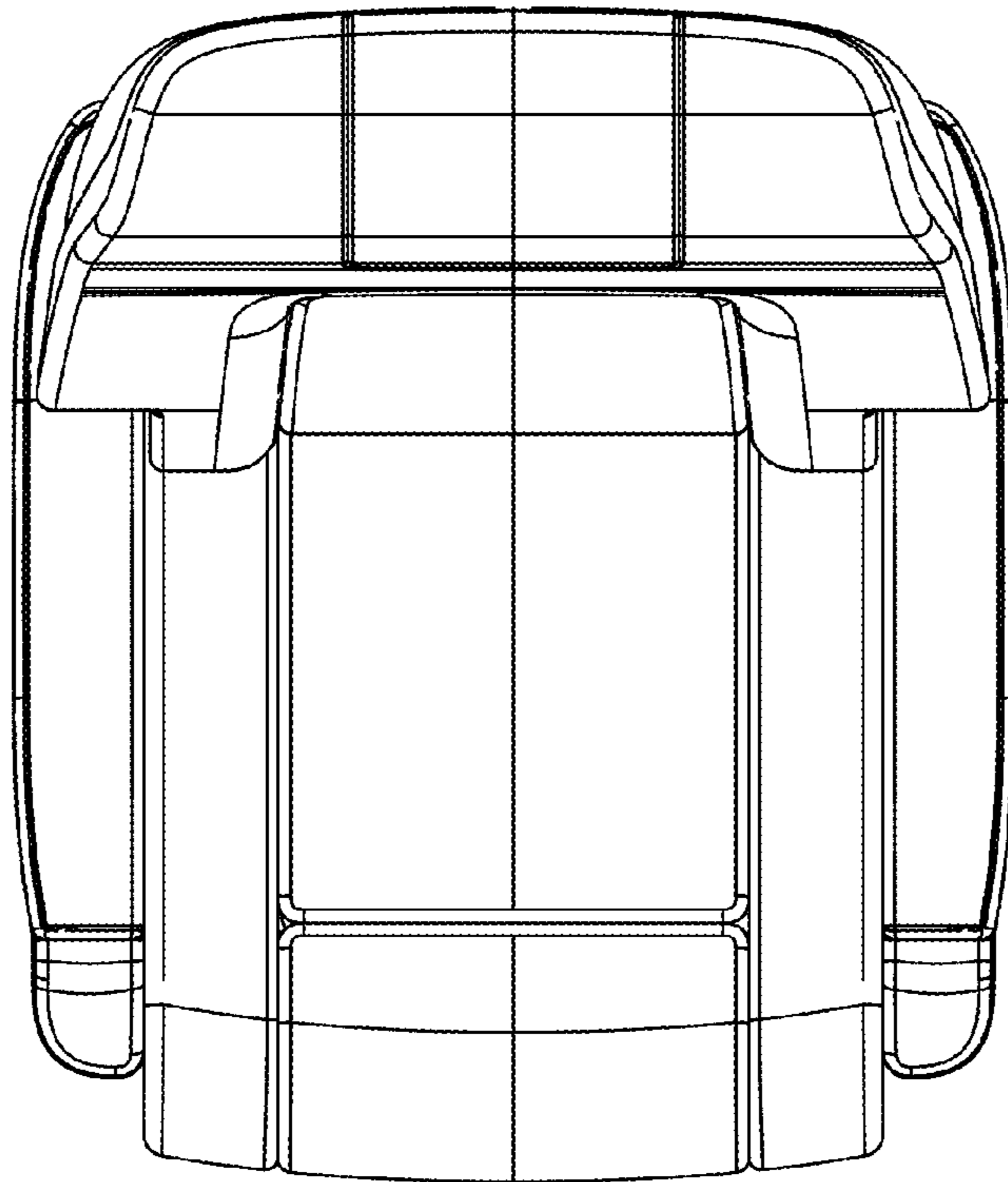

FIG. 6

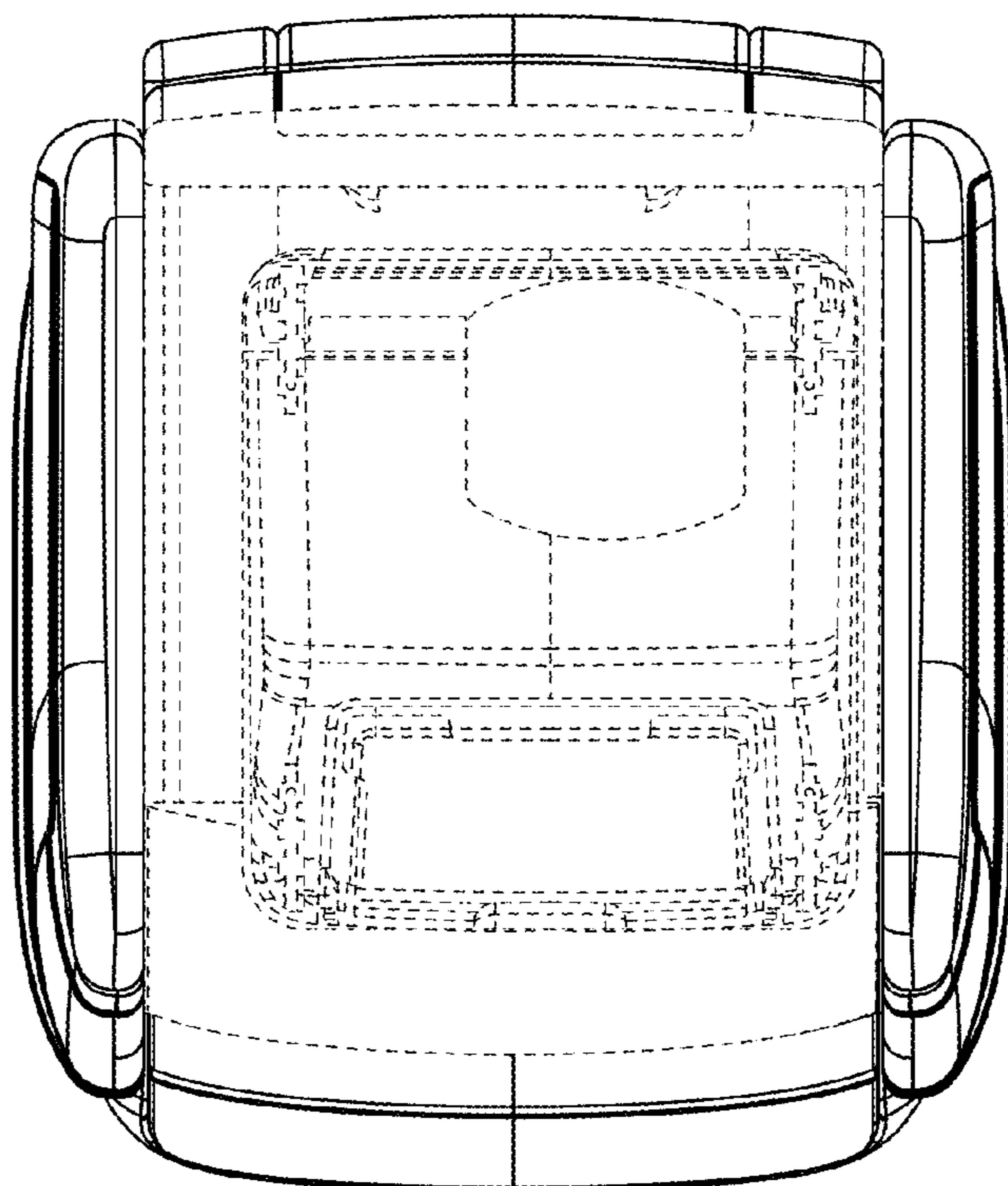

FIG. 7

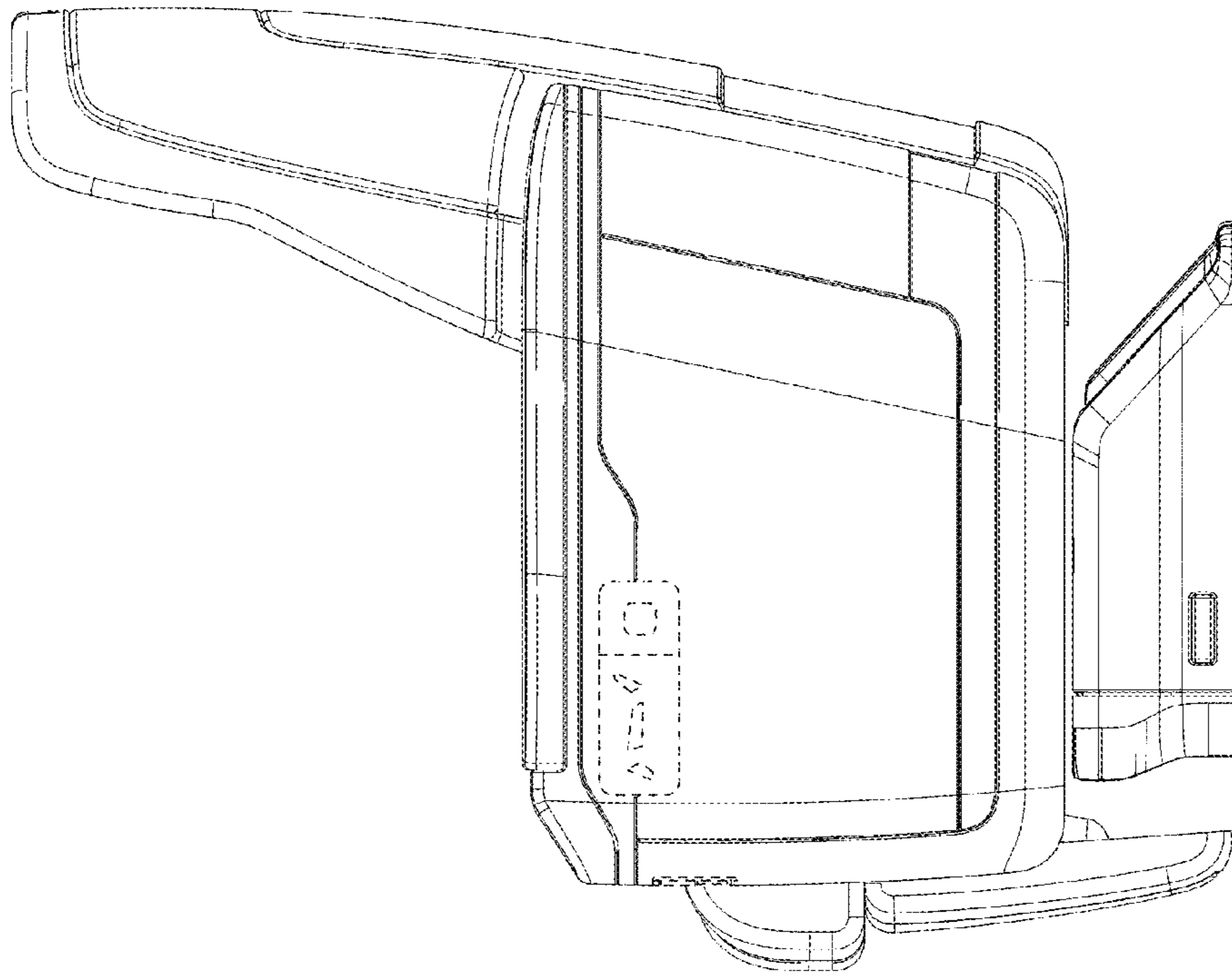

FIG. 9

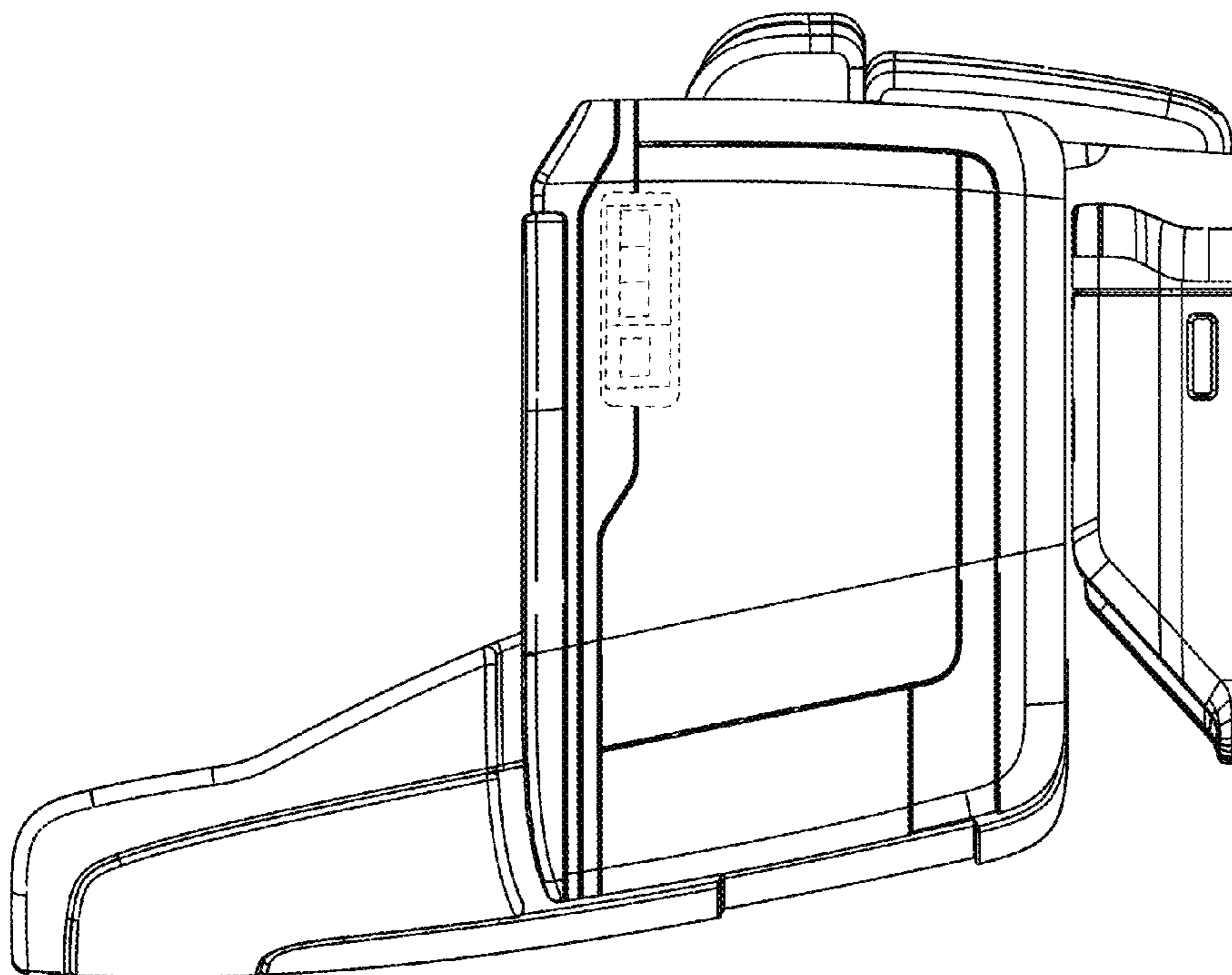

FIG. 8