



US00D748156S

(12) **United States Design Patent**  
**Koponen et al.**

(10) **Patent No.:** **US D748,156 S**  
(45) **Date of Patent:** **\*\* Jan. 26, 2016**

- (54) **LIFT TRUCK CABIN**
- (71) Applicant: **Konecranes Plc**, Hyvinkää (FI)
- (72) Inventors: **Sami Koponen**, Helsinki (FI); **Jan Anders Ove Sjostrand**, Lagan (SE); **David Jaan Vilhelm Backman**, Markaryd (SE)
- (73) Assignee: **Konecranes Plc**, Hyvinkää (FI)
- (\*\*) Term: **14 Years**
- (21) Appl. No.: **29/508,822**
- (22) Filed: **Nov. 11, 2014**
- (30) **Foreign Application Priority Data**

D479,536 S *	9/2003	Dahl	.....	D15/30
D528,134 S *	9/2006	Vandendriessche	.....	D15/30
D541,825 S *	5/2007	Pettersson	.....	D15/30
D549,245 S *	8/2007	Antonetti	.....	D15/30
D561,205 S *	2/2008	Pettersson	.....	D15/30
D579,028 S *	10/2008	VanDeVeer	.....	D15/30
D594,480 S *	6/2009	Gicquel	.....	D15/30
D605,207 S *	12/2009	Menges	.....	D15/30
D625,741 S *	10/2010	Seidel	.....	D15/30
D635,156 S *	3/2011	Berning	.....	D15/30
D637,630 S *	5/2011	Yamamoto	.....	D15/30
D642,205 S *	7/2011	Yamamoto	.....	D15/30
D650,816 S *	12/2011	Koponen	.....	D15/30
D660,881 S *	5/2012	Bohme	.....	D15/30
D661,321 S *	6/2012	Bohme	.....	D15/22
D667,851 S *	9/2012	Warr	.....	D15/30
D668,693 S *	10/2012	Ringer	.....	D15/30
D670,745 S *	11/2012	Warr	.....	D15/30
D671,566 S *	11/2012	Fang	.....	D15/30
D678,360 S *	3/2013	Kozai	.....	D15/30
D687,868 S *	8/2013	Watson	.....	D15/30

- May 13, 2014 (EM) ..... 002462820-0001
- (51) **LOC (10) Cl.** ..... **15-03**
- (52) **U.S. Cl.**  
USPC ..... **D15/30**
- (58) **Field of Classification Search**  
USPC ..... D15/28, 30, 31, 22-26; D34/37;  
180/89.11, 89.12, 89.13, 89.19, 900  
CPC ..... B66C 13/54; E02F 9/16; E02F 9/163;  
B62D 33/0617; B60J 7/00; B60J 1/004  
See application file for complete search history.

\* cited by examiner

*Primary Examiner* — Mark Goodwin  
(74) *Attorney, Agent, or Firm* — Clinton H. Wilkinson;  
Charles A. Wilkinson

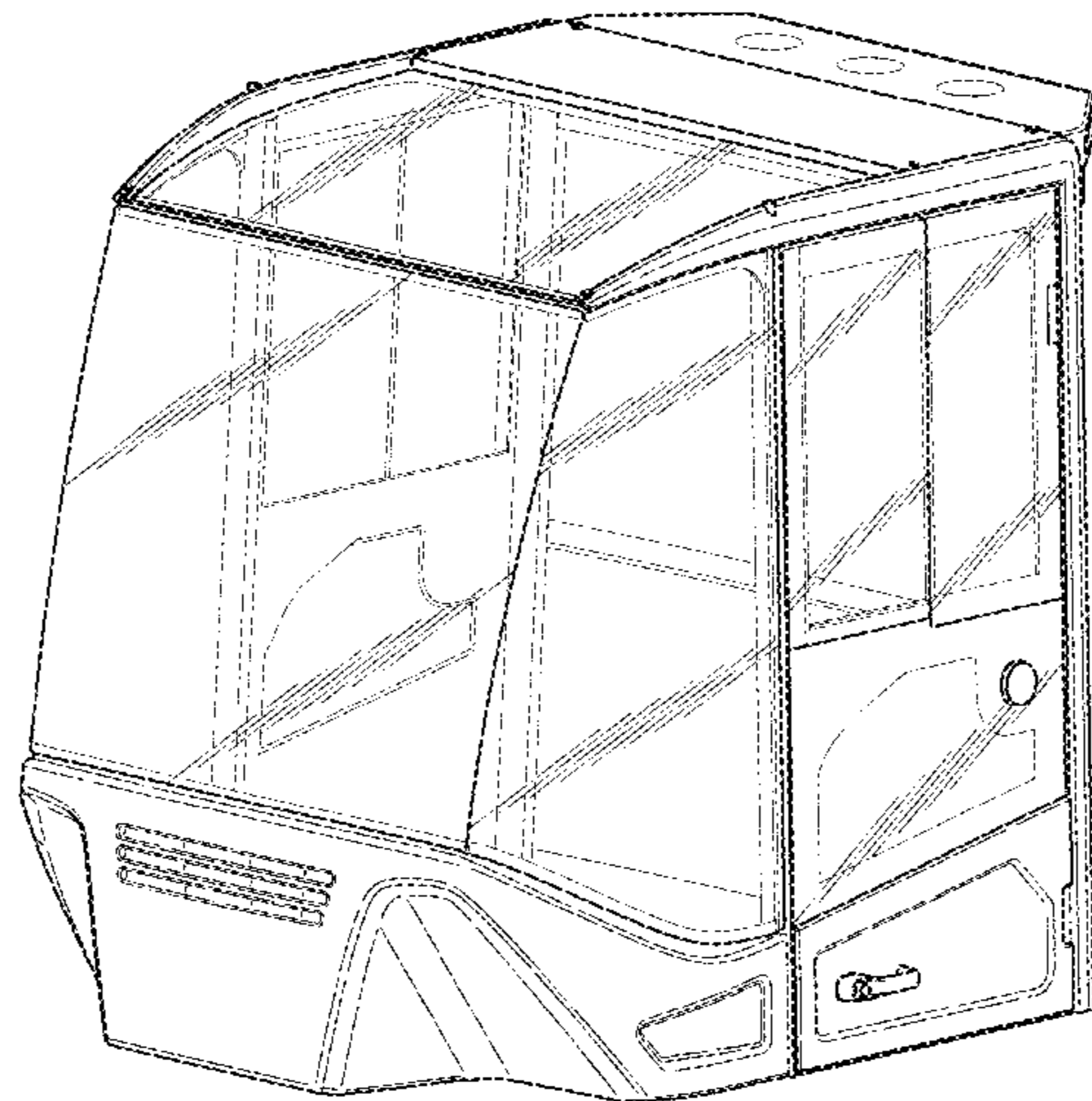
- (56) **References Cited**  
U.S. PATENT DOCUMENTS
- |               |         |                  |       |                        |
|---------------|---------|------------------|-------|------------------------|
| D274,063 S *  | 5/1984  | Skaff            | ..... | D15/30                 |
| D312,827 S *  | 12/1990 | Boddin           | ..... | D15/30                 |
| D323,659 S *  | 2/1992  | Jacobsson        | ..... | D15/30                 |
| 5,096,253 A * | 3/1992  | Jo               | ..... | B60J 1/04<br>296/190.1 |
| D455,763 S *  | 4/2002  | Brandenburg, III | ..... | D15/30                 |
| D471,213 S *  | 3/2003  | Kwak             | ..... | D15/30                 |

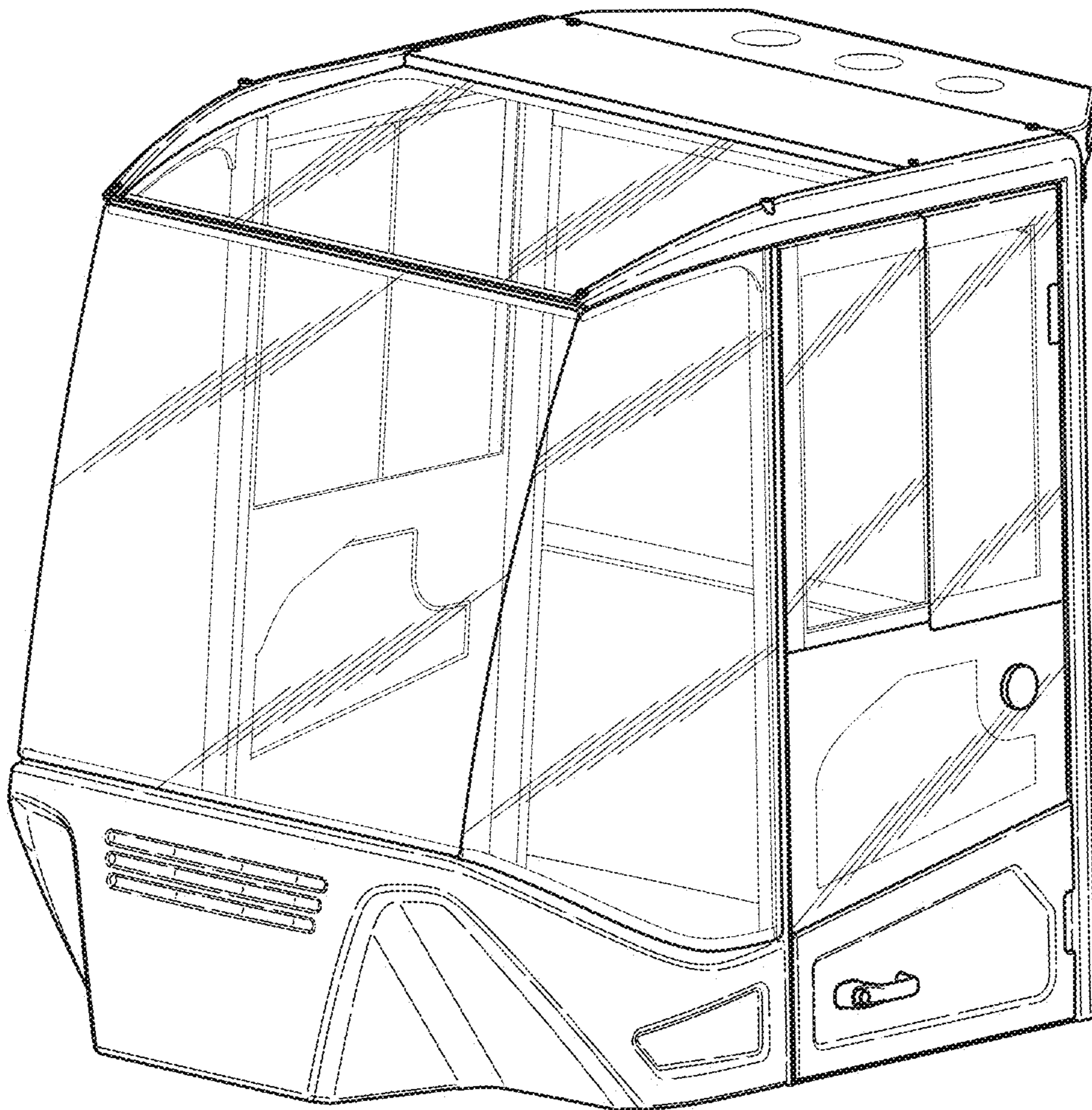
(57) **CLAIM**  
The ornamental design for a lift truck cabin, as shown and described.

**DESCRIPTION**

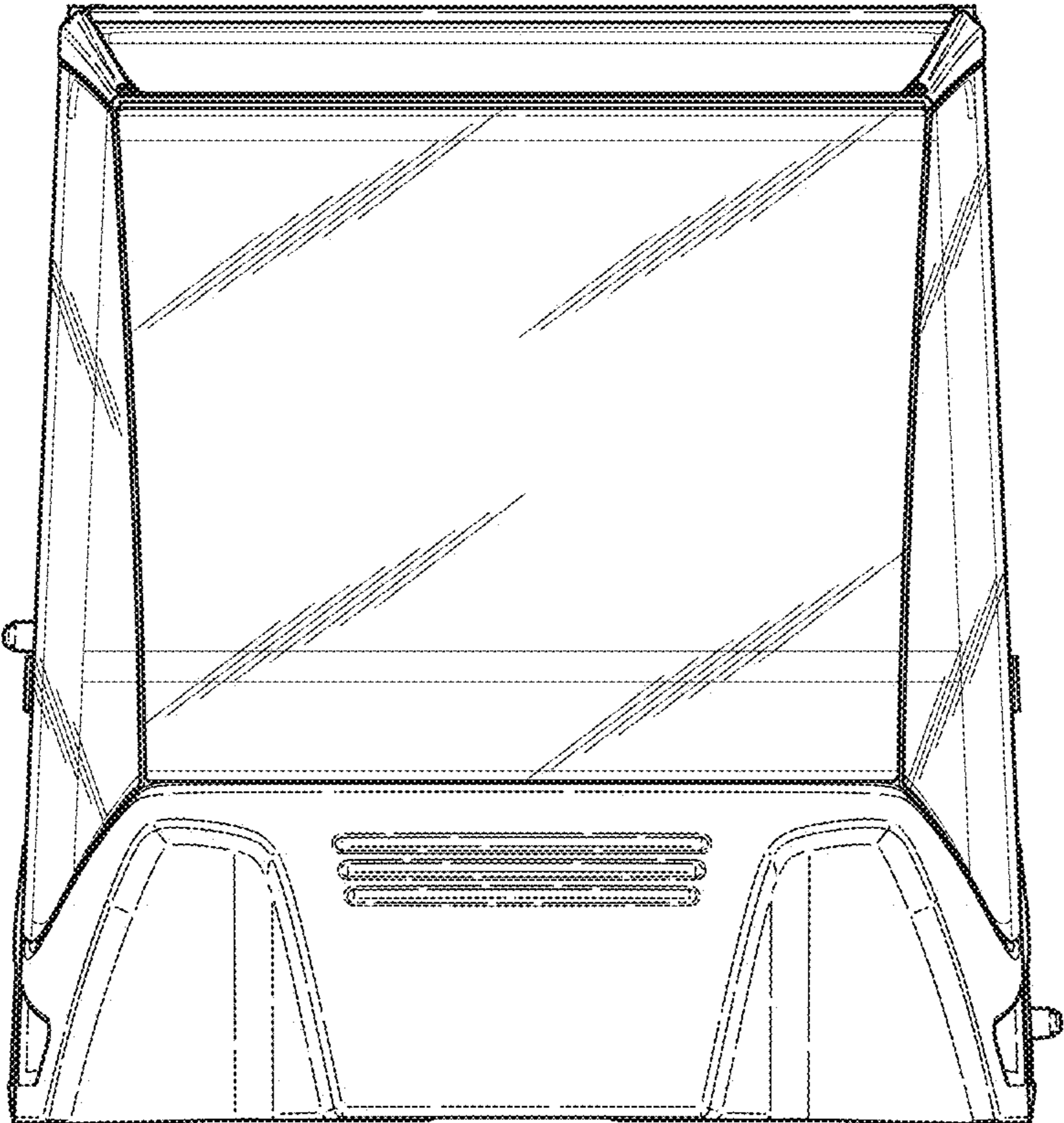
FIG. 1 is an isometric view of a lift truck cabin showing our new design;  
FIG. 2 is a front elevation view thereof;  
FIG. 3 is a right elevation view thereof;  
FIG. 4 is a left side view thereof;  
FIG. 5 is a back side view thereof; and,  
FIG. 6 is a top view thereof.

**1 Claim, 6 Drawing Sheets**

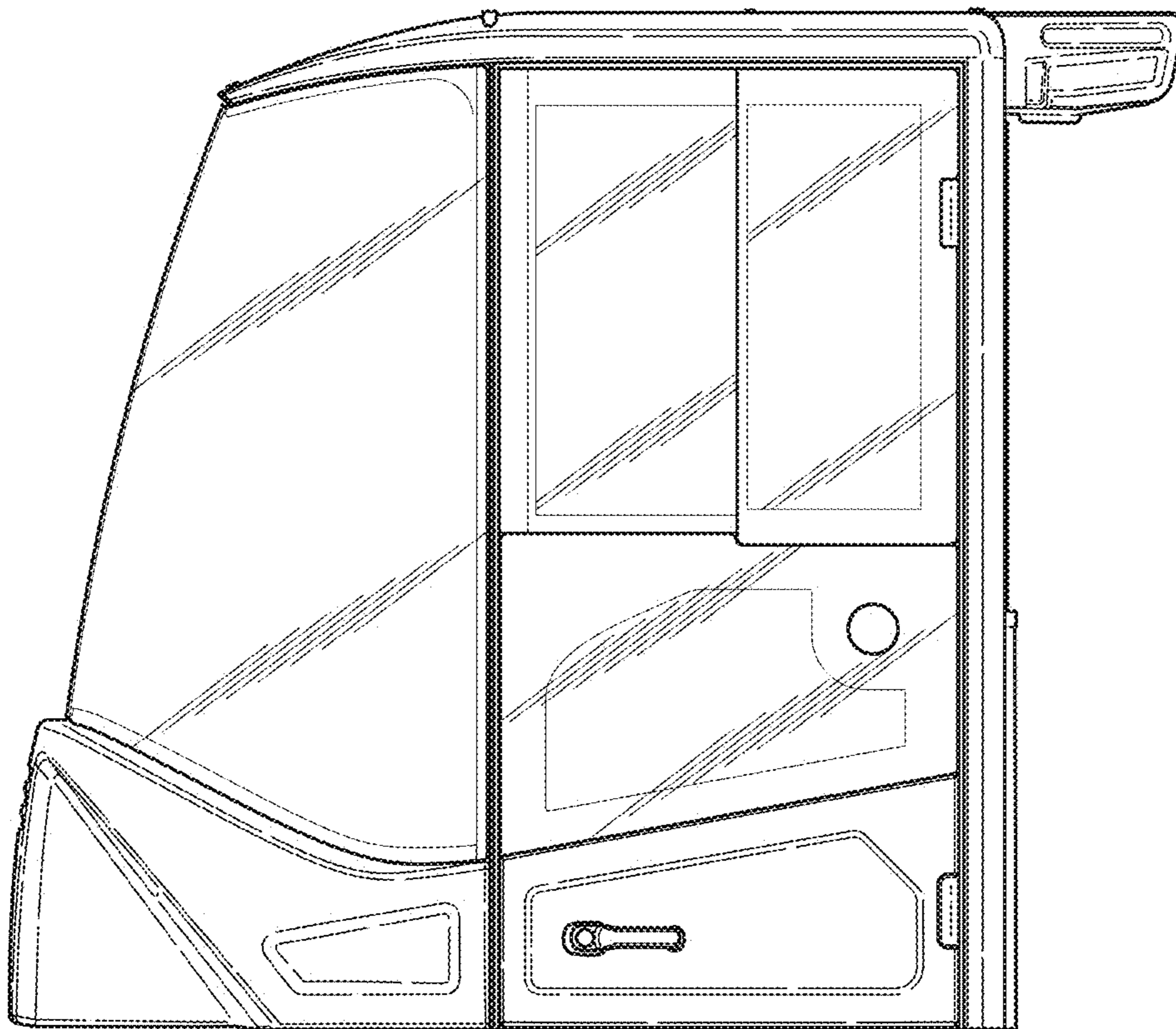




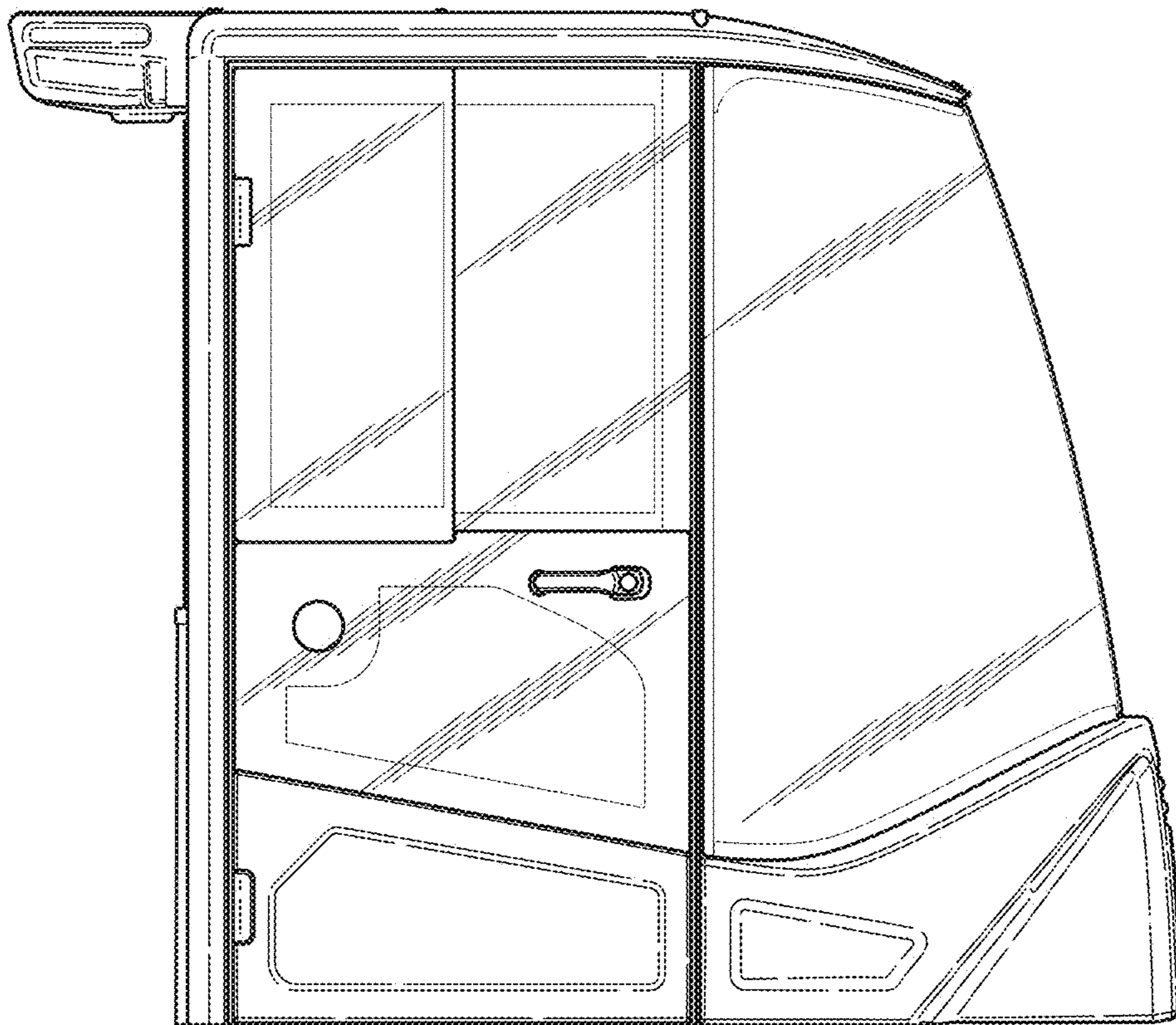
*FIG. 1*



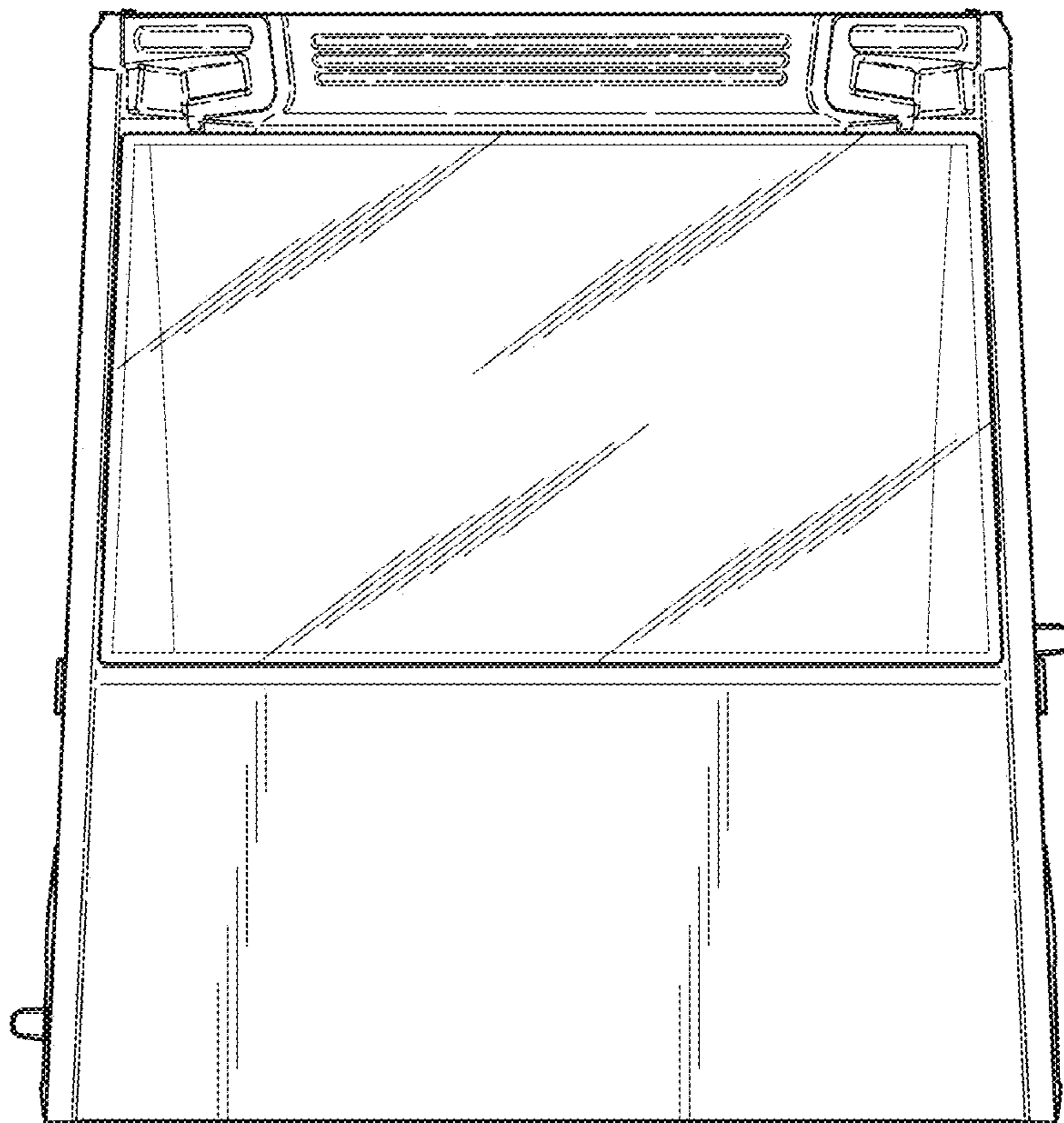
*FIG. 2*



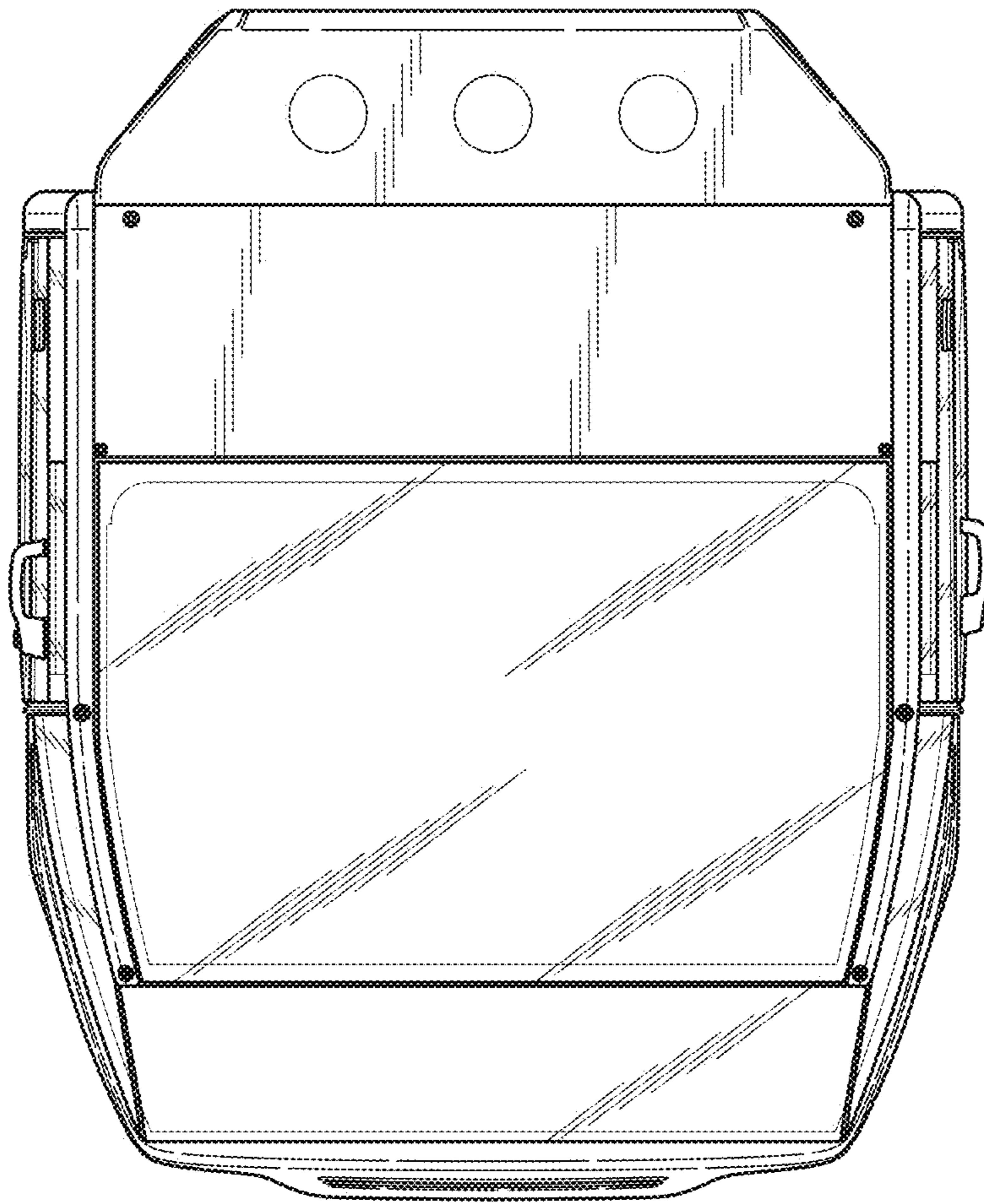
*FIG. 3*



*FIG. 4*



*FIG. 5*



*FIG. 6*