



US00D748154S

(12) **United States Design Patent**  
**Cherry**

(10) **Patent No.:** **US D748,154 S**  
(45) **Date of Patent:** **\*\* Jan. 26, 2016**

- (54) **SELF-ALIGNING AXIAL DRIVE COUPLING MEMBER**
- (71) Applicant: **Deere & Company**, Moline, IL (US)
- (72) Inventor: **Brandon C. Cherry**, Geneseo, IL (US)
- (73) Assignee: **DEERE & COMPANY**, Moline, IL (US)
- (\*\*) Term: **14 Years**
- (21) Appl. No.: **29/511,881**
- (22) Filed: **Dec. 15, 2014**
- (51) **LOC (10) Cl.** ..... **15-03**
- (52) **U.S. Cl.**  
USPC ..... **D15/28**
- (58) **Field of Classification Search**  
USPC ..... D15/10, 11, 13, 17, 28; 111/178, 77, 111/164, 184, 193, 921, 922, 104; 74/13, 74/10 R, 10.85, 14; 172/105; 403/403  
CPC ..... A01C 7/102; A01C 19/00; F16D 41/185; F16D 41/22; F16D 1/08; F16D 1/0817; F16D 1/06; F16D 3/78; F16D 3/50  
See application file for complete search history.

(56) **References Cited**

U.S. PATENT DOCUMENTS

- 1,975,877 A \* 10/1934 Thomas ..... B23B 31/13 279/9.1
- 3,884,049 A \* 5/1975 Pauli ..... F16D 3/68 464/182
- 4,228,664 A \* 10/1980 McCoy ..... F16D 1/08 464/73
- 4,357,137 A \* 11/1982 Brown ..... F16D 1/06 464/150
- 4,376,630 A \* 3/1983 Hampel ..... F16D 3/50 464/147
- 4,860,270 A \* 8/1989 Kroener ..... G04B 11/00

- 6,729,250 B2 \* 5/2004 Friestad ..... 368/322 A01C 19/00 111/177
- 6,745,710 B2 \* 6/2004 Friestad ..... F16D 1/0894 111/178
- 7,014,387 B2 \* 3/2006 Harrison ..... F16D 1/096 403/368
- D568,348 S \* 5/2008 Tsui ..... D15/138
- 8,151,718 B2 \* 4/2012 Mariman ..... A01C 7/102 111/164
- 2002/0192022 A1 \* 12/2002 Harrison ..... F16D 1/096 403/403
- 2004/0025765 A1 \* 2/2004 Friestad ..... F16D 1/0894 111/158
- 2010/0294612 A1 \* 11/2010 Mariman ..... A01C 7/102 192/69.81

\* cited by examiner

*Primary Examiner* — Mark Goodwin

(57) **CLAIM**

The ornamental design for a self-aligning axial drive coupling member, design as shown and described.

**DESCRIPTION**

FIG. 1 is a front perspective view of a self-aligning axial drive coupling member.  
 FIG. 2 is a bottom view of the self-aligning axial drive coupling member, design of FIG. 1.  
 FIG. 3 is a top view of the self-aligning axial drive coupling member, design of FIG. 1.  
 FIG. 4 is a right view of the self-aligning axial drive coupling member, design of FIG. 1.  
 FIG. 5 is a left view of the self-aligning axial drive coupling member, design of FIG. 1.  
 FIG. 6 is a rear view of the self-aligning axial drive coupling member, design of FIG. 1; and,  
 FIG. 7 is a front view of the self-aligning axial drive coupling member, design of FIG. 1.

**1 Claim, 4 Drawing Sheets**

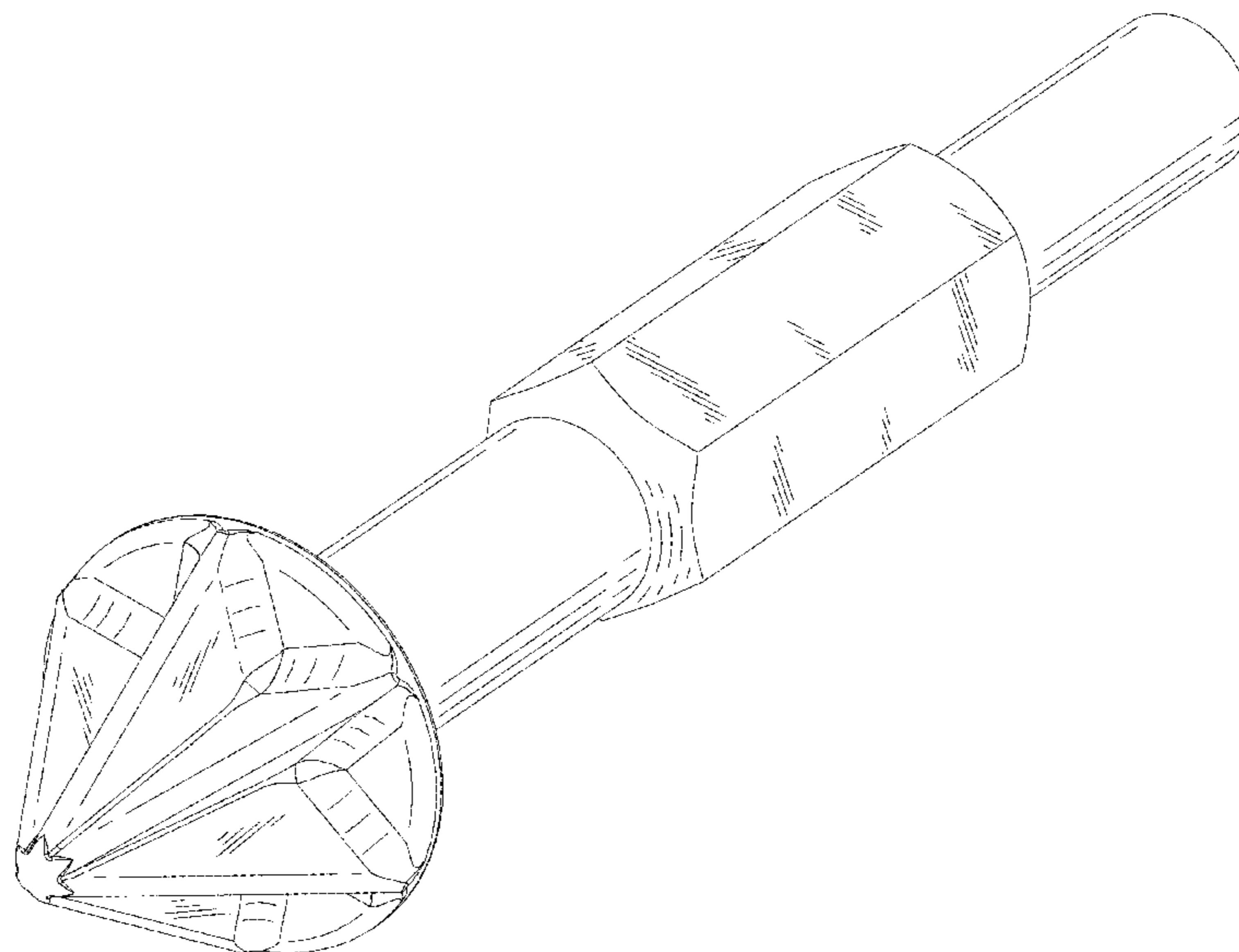

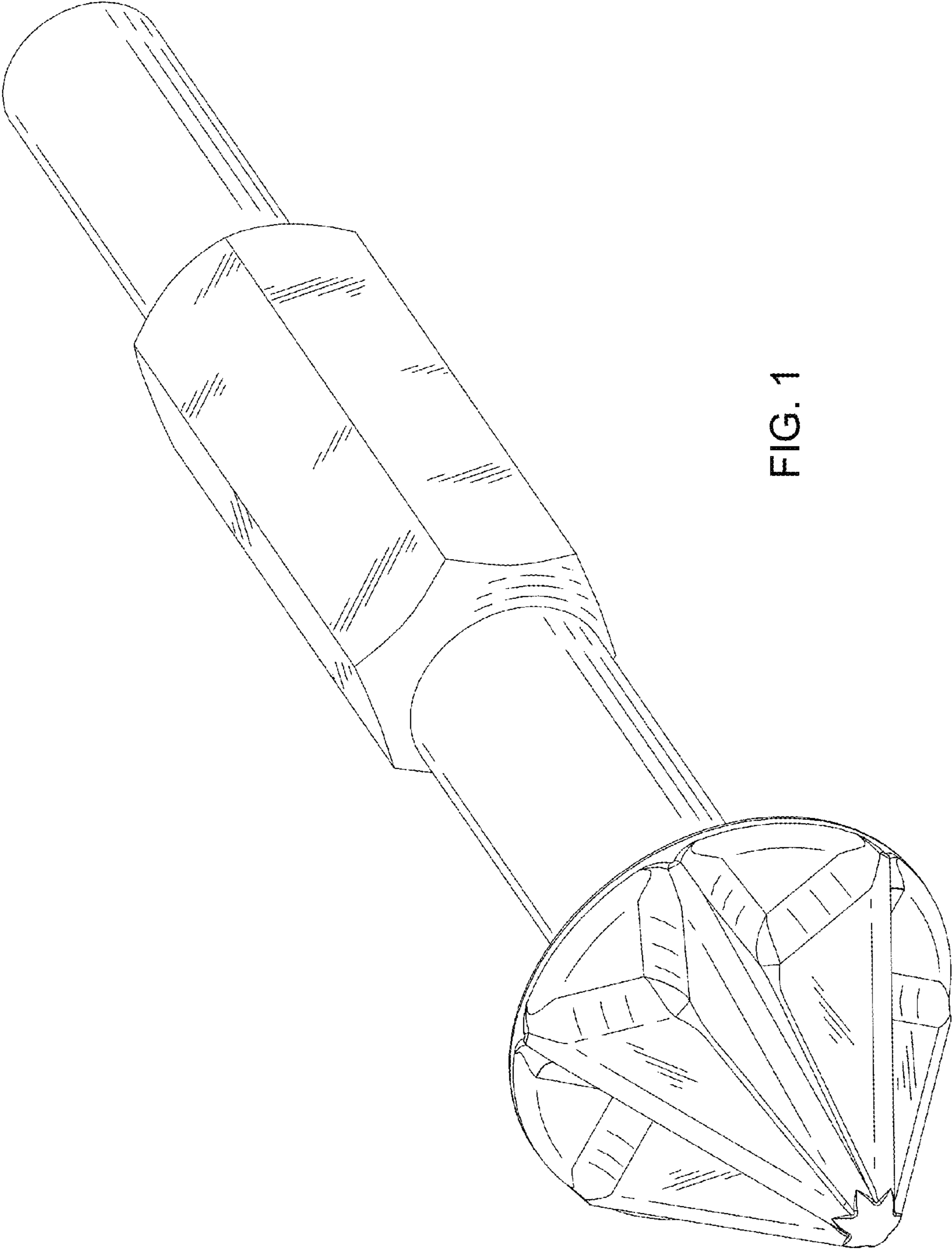

FIG. 1

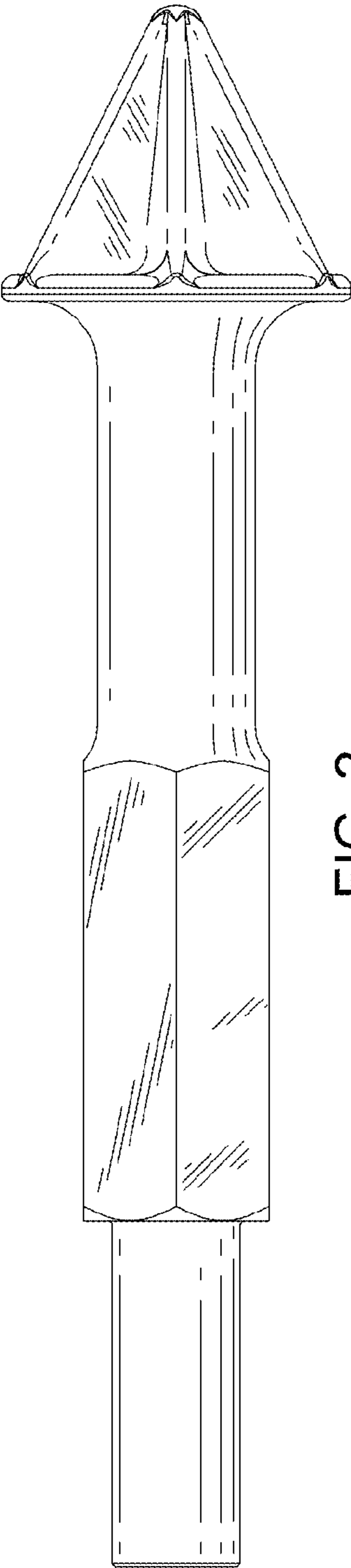

FIG. 2

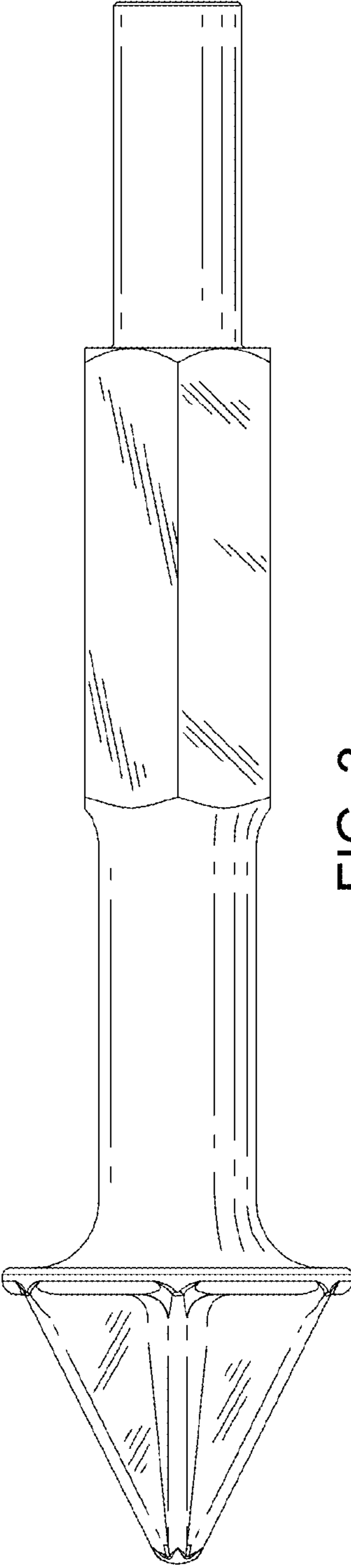

FIG. 3

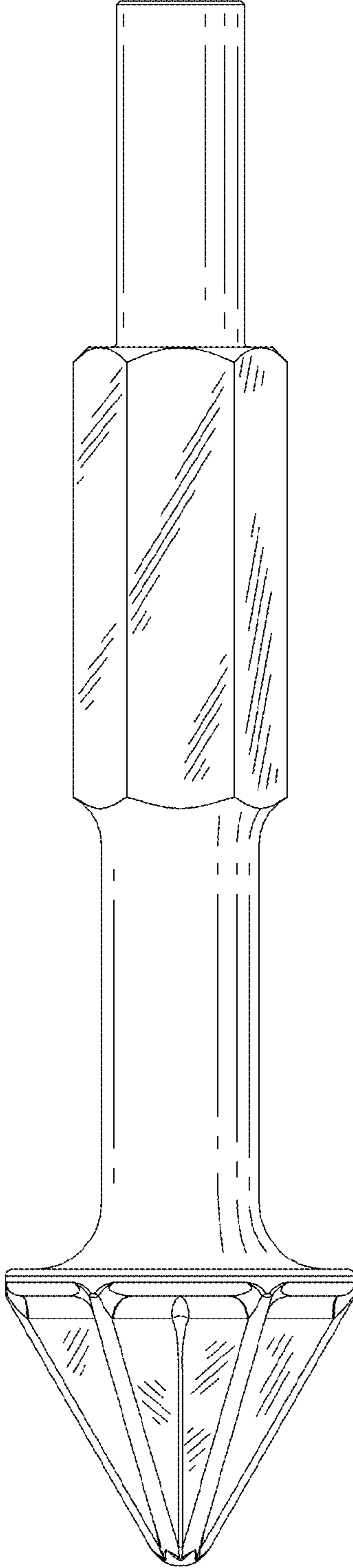

FIG. 4

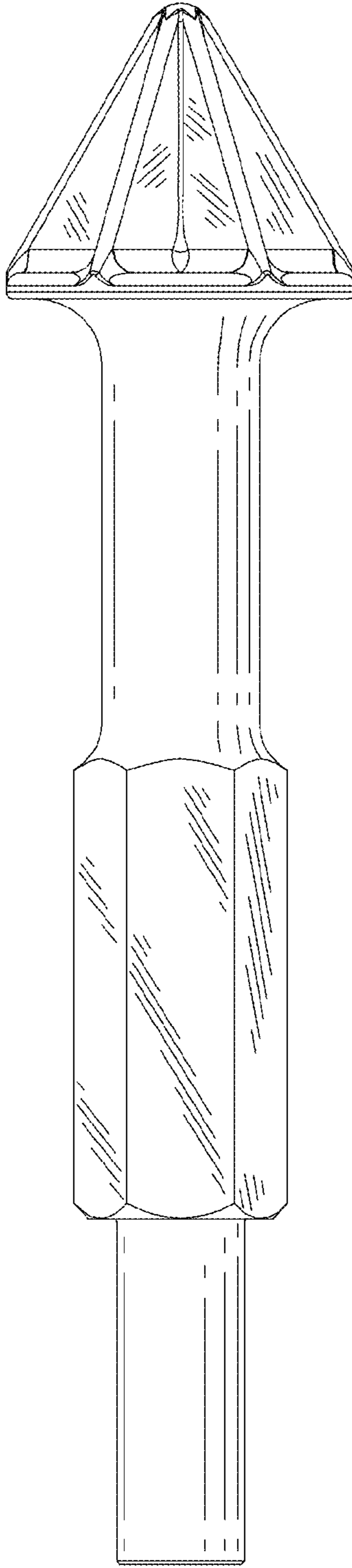

FIG. 5

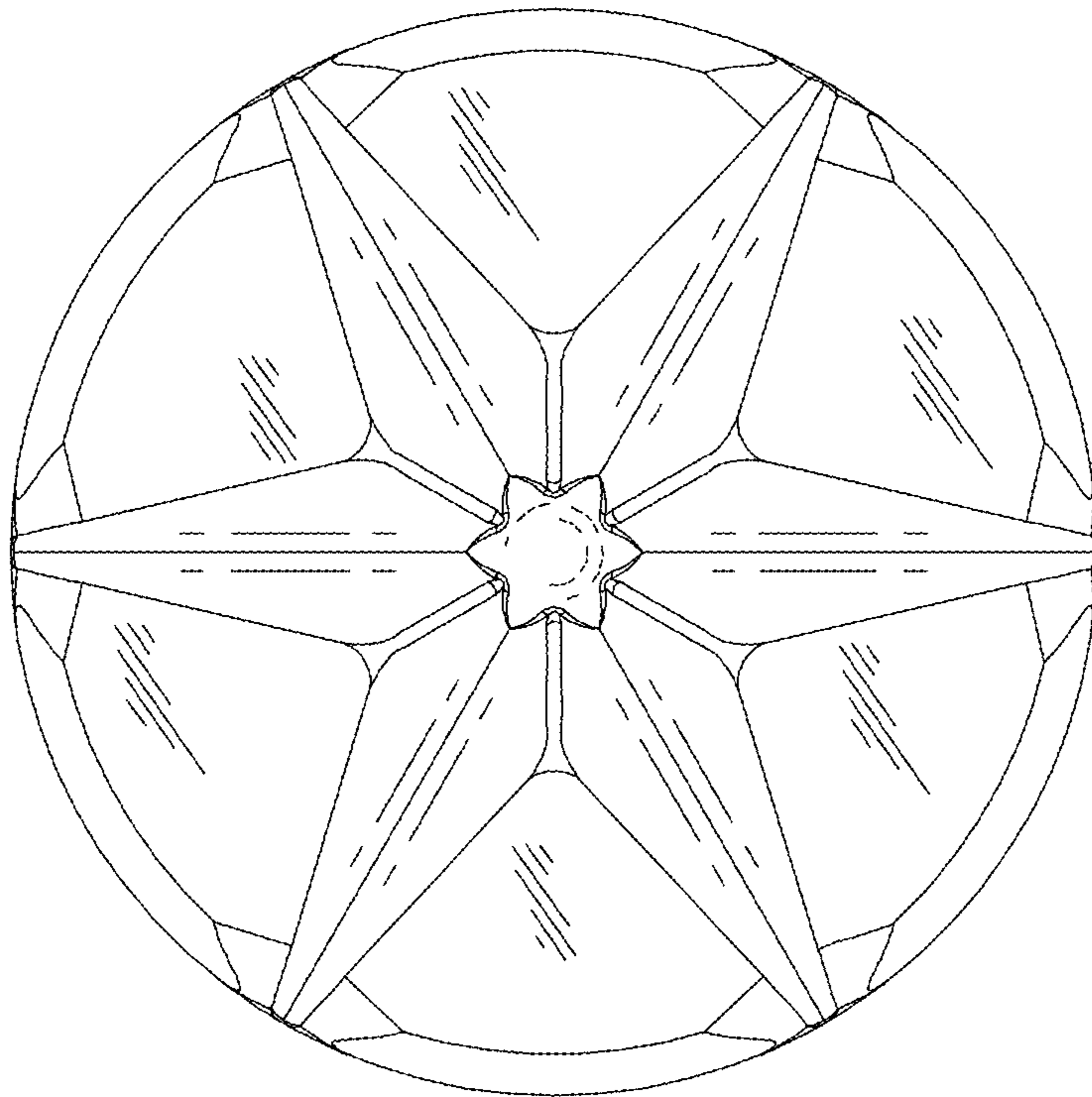

FIG. 7



FIG. 6