



US00D748036S

(12) **United States Design Patent**
Hilpert

(10) **Patent No.:** **US D748,036 S**

(45) **Date of Patent:** **** Jan. 26, 2016**

(54) **WHEEL COVER OR WHEEL HUB COVER**

(71) Applicant: **Daimler AG**, Stuttgart (DE)

(72) Inventor: **Kai Hilpert**, Plochingen (DE)

(73) Assignee: **Daimler AG**, Stuttgart (DE)

(**) Term: **14 Years**

(21) Appl. No.: **29/451,792**

(22) Filed: **Apr. 9, 2013**

(30) **Foreign Application Priority Data**

Oct. 10, 2012 (EM) 002116699-0001

Oct. 10, 2012 (EM) 002116699-0003

(51) **LOC (10) Cl.** **12-16**

(52) **U.S. Cl.**
USPC **D12/213**

(58) **Field of Classification Search**
USPC D12/204-213

CPC B60B 7/00; B60B 7/02; B60B 7/04;
B60B 7/01; B60B 7/06; B60B 3/02; B60B
3/04; B60B 3/06; B60B 3/10; B60B 1/00;
B60B 1/08; B60B 1/10; B60B 1/12

See application file for complete search history.

(56) **References Cited**

U.S. PATENT DOCUMENTS

D188,536 S * 8/1960 Nixon D12/204

D191,354 S * 9/1961 Zierhut D12/204

D191,394 S *	9/1961	Garcia	D12/204
3,025,110 A *	3/1962	Lyon	D12/213
D202,774 S *	11/1965	Nash	D12/204
D297,632 S *	9/1988	Marshall	D12/213
D392,240 S *	3/1998	Kingsland	D12/213
D392,929 S *	3/1998	Lombard	D12/204
D407,362 S *	3/1999	Schardt	D12/204
D453,914 S *	2/2002	Dumigan	D12/213
D542,211 S *	5/2007	Hieke	D12/211
D702,174 S *	4/2014	Gordon	D12/213

* cited by examiner

Primary Examiner — Stacia Cadmus

(74) *Attorney, Agent, or Firm* — Crowell & Moring LLP

(57) **CLAIM**

The ornamental design for a wheel cover or wheel hub cover, as shown and described.

DESCRIPTION

FIG. 1 is a perspective view of a first embodiment of a wheel cover or wheel hub cover according to the design;

FIG. 2 is a front view thereof; and

FIG. 3 is a reduced perspective view thereof, shown in its position of use.

FIG. 4 is a perspective view of a second embodiment of the wheel cover or wheel hub cover according to the design;

FIG. 5 is a front view thereof; and,

FIG. 6 is a reduced perspective view thereof, shown in its position of use.

The broken line showing of the wheel, parts for attachment, and configurations on the central hub area is included for the purpose of illustrating environment and forms no part of the claimed design.

1 Claim, 4 Drawing Sheets

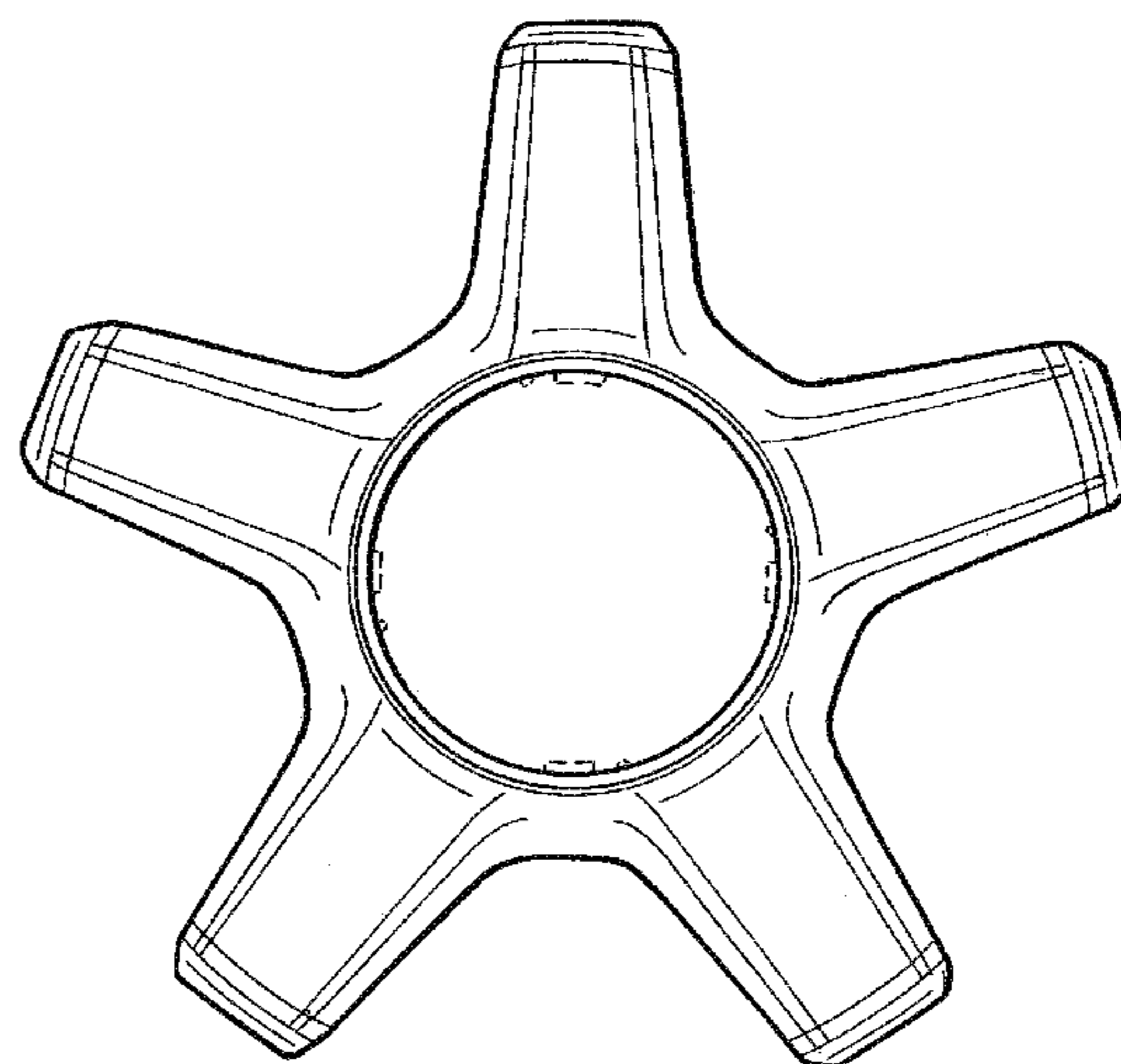
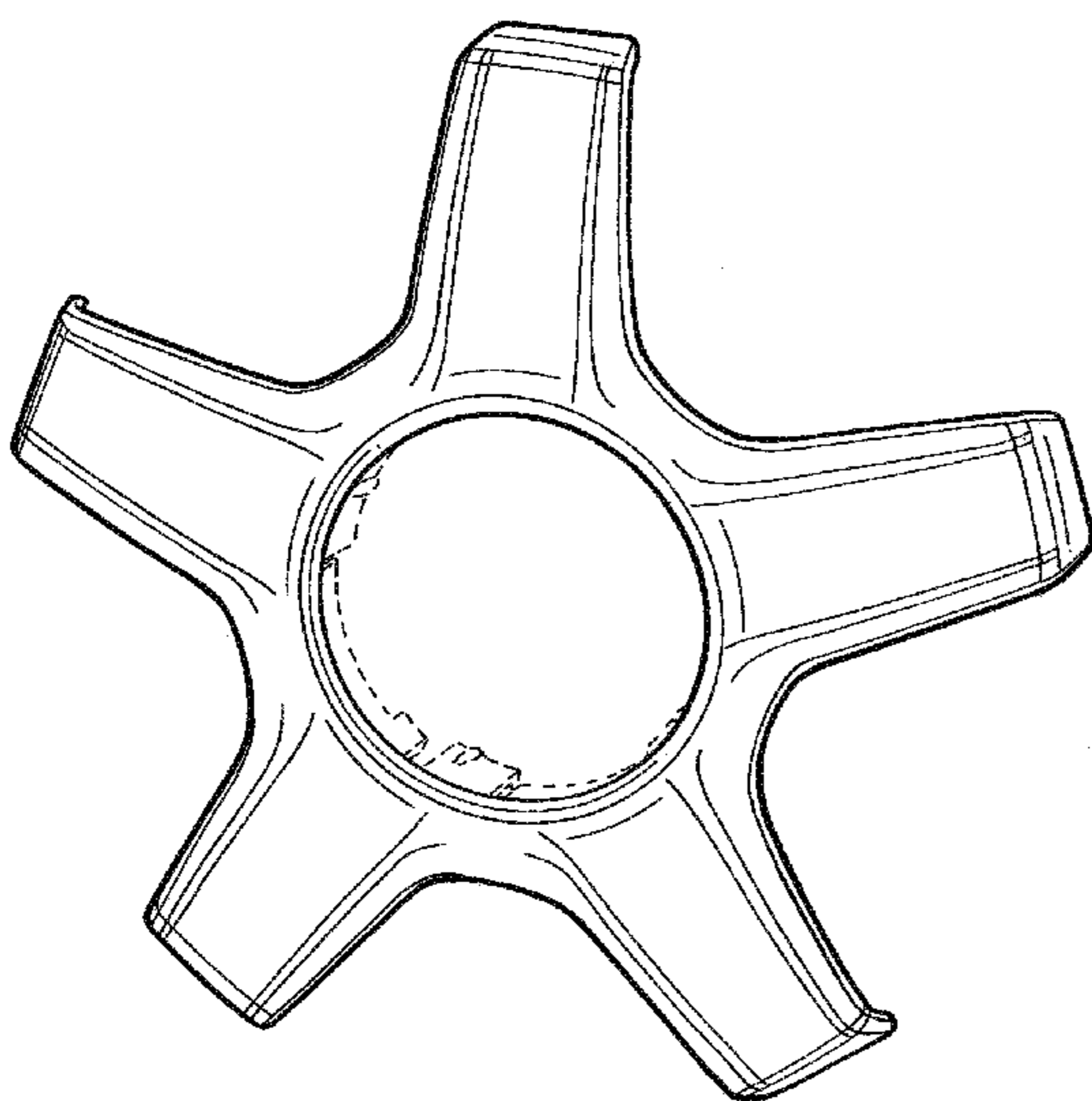

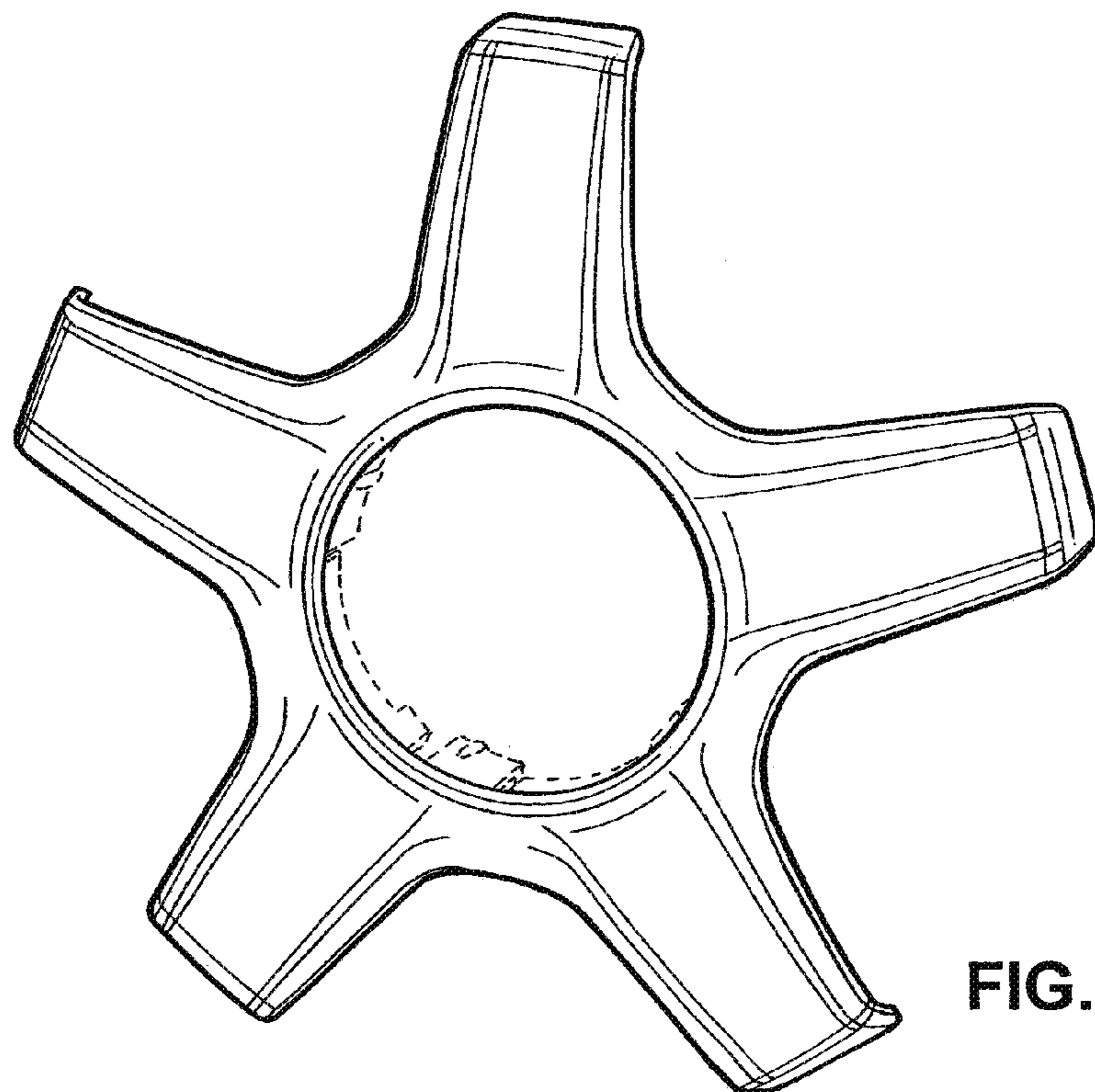

FIG. 1

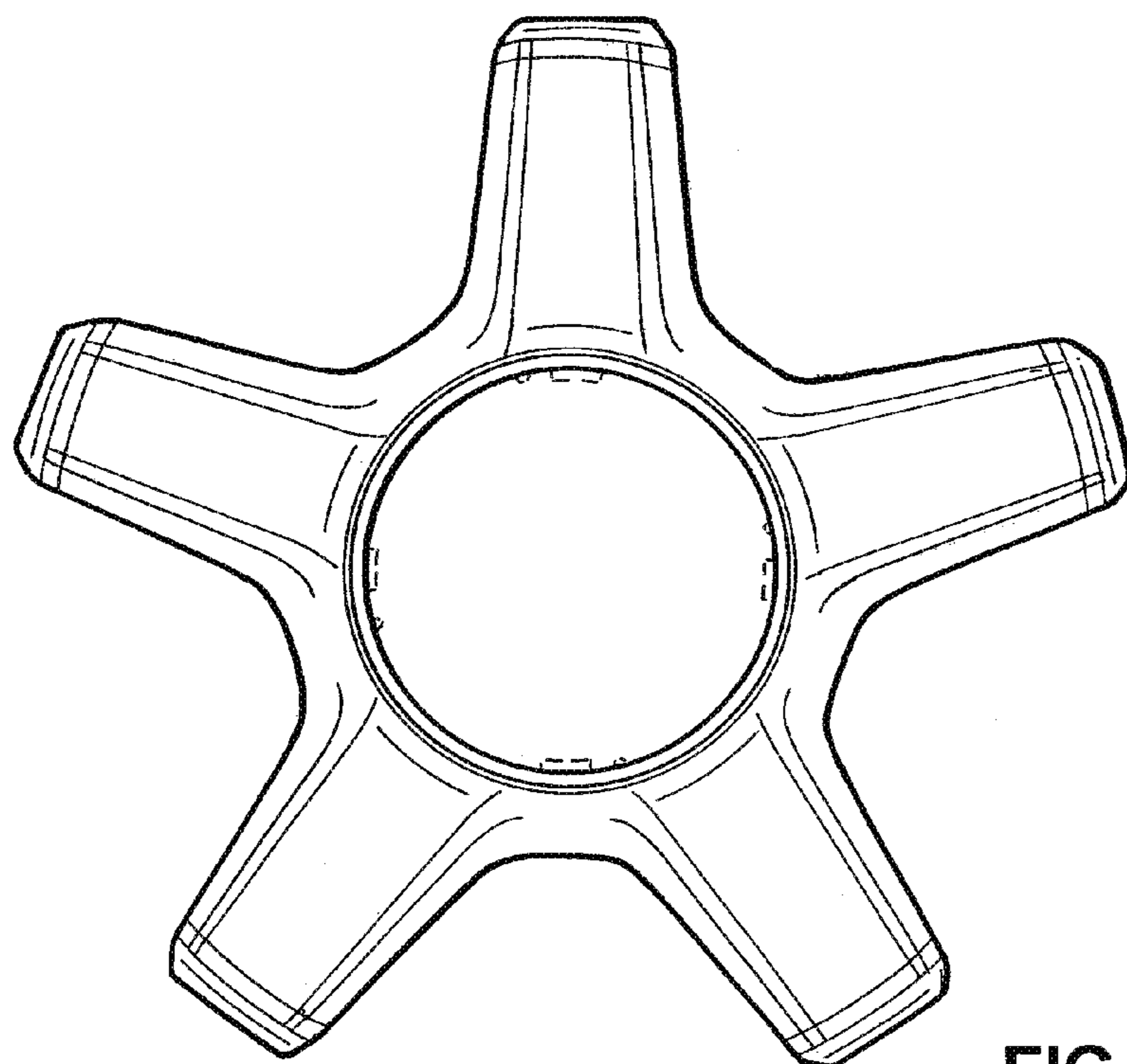

FIG. 2

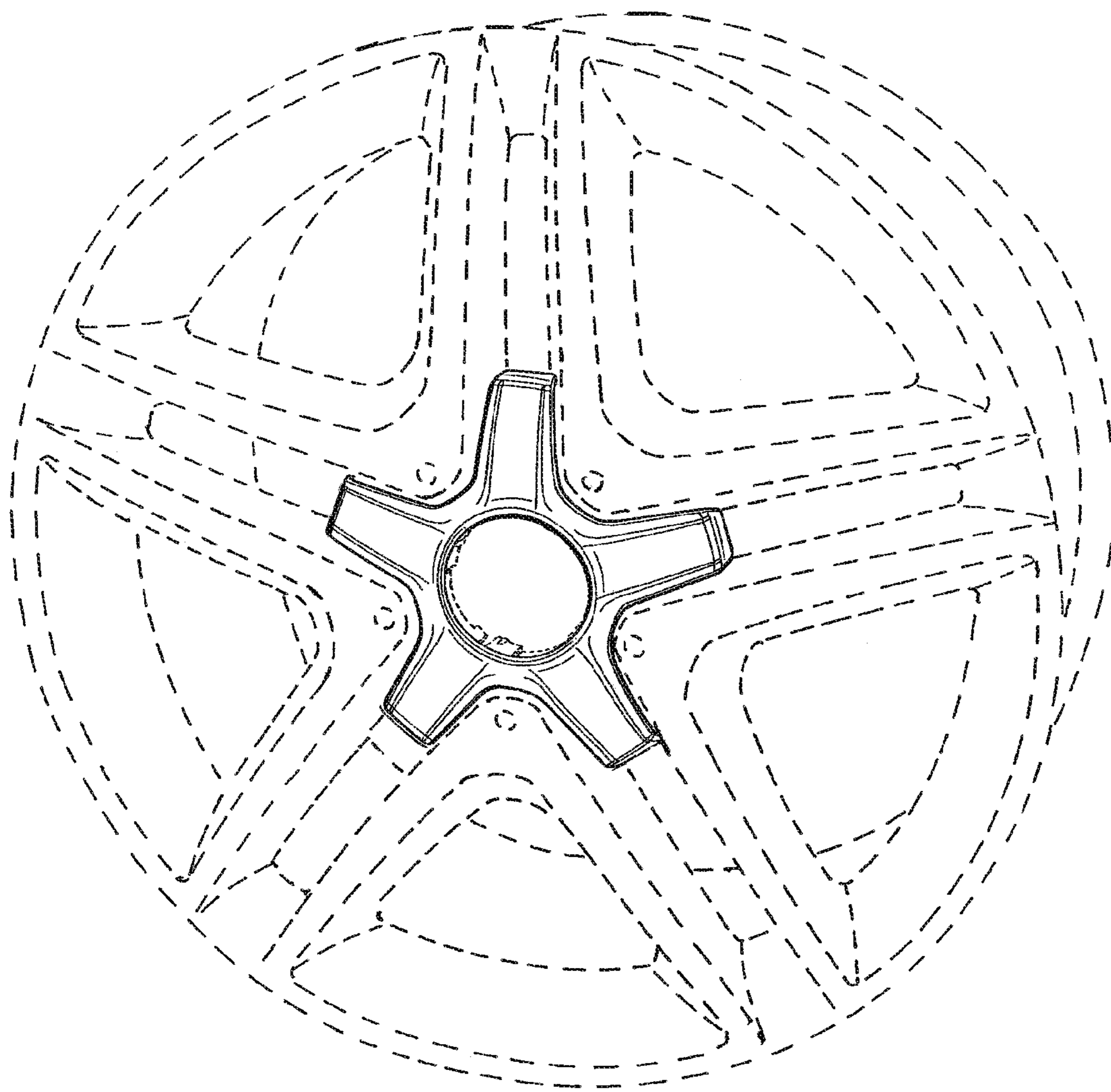

FIG. 3

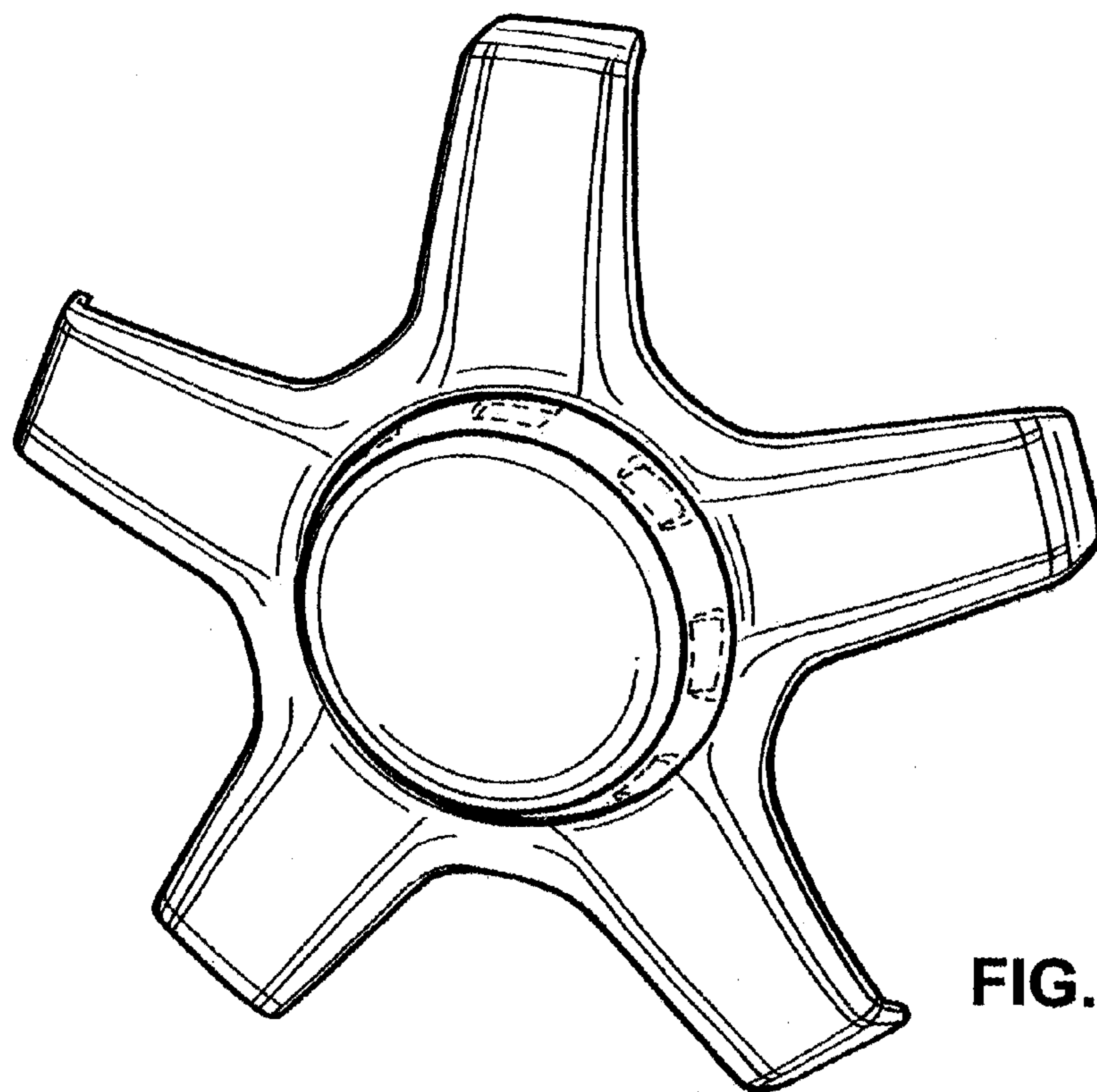

FIG. 4

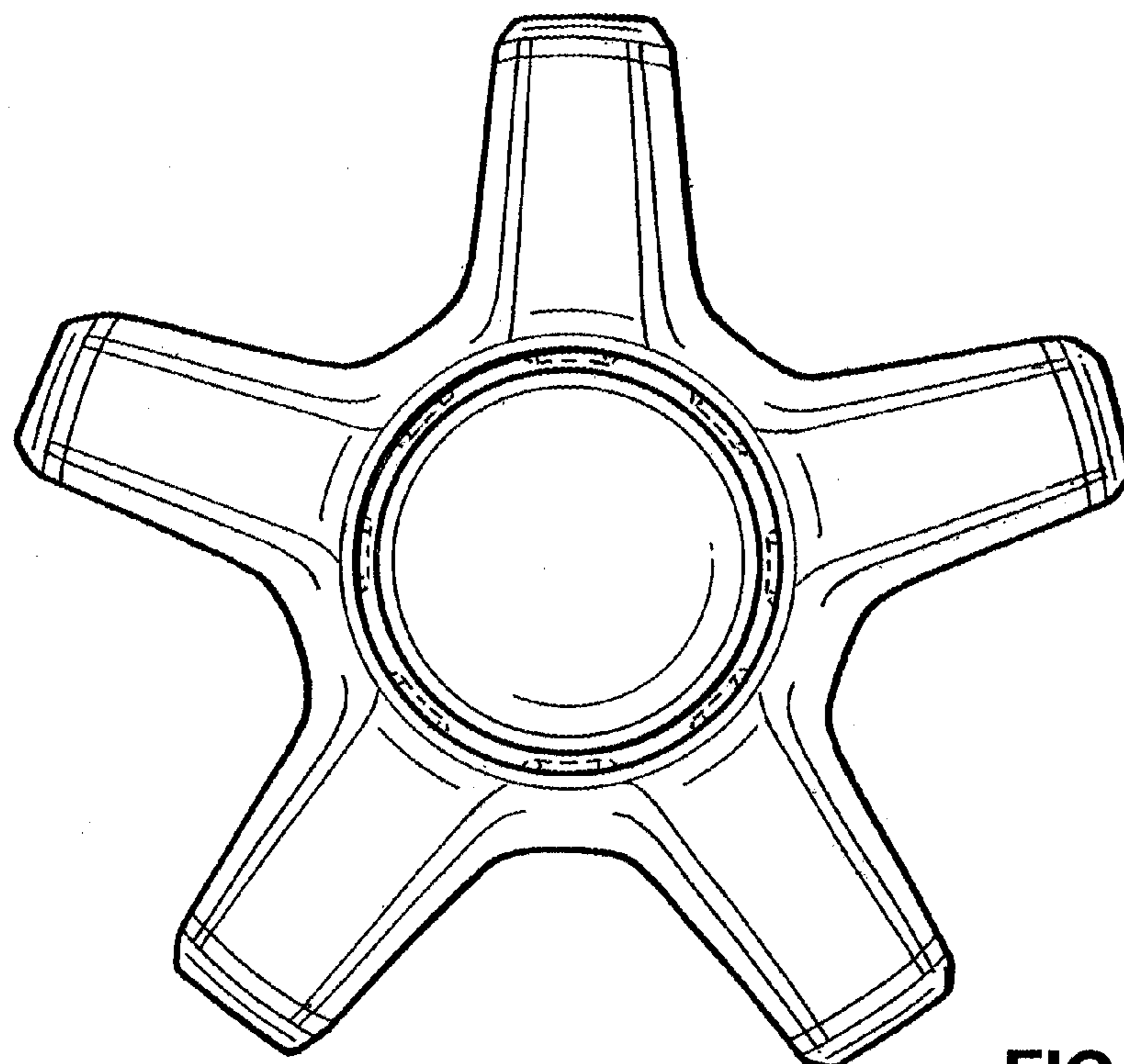

FIG. 5

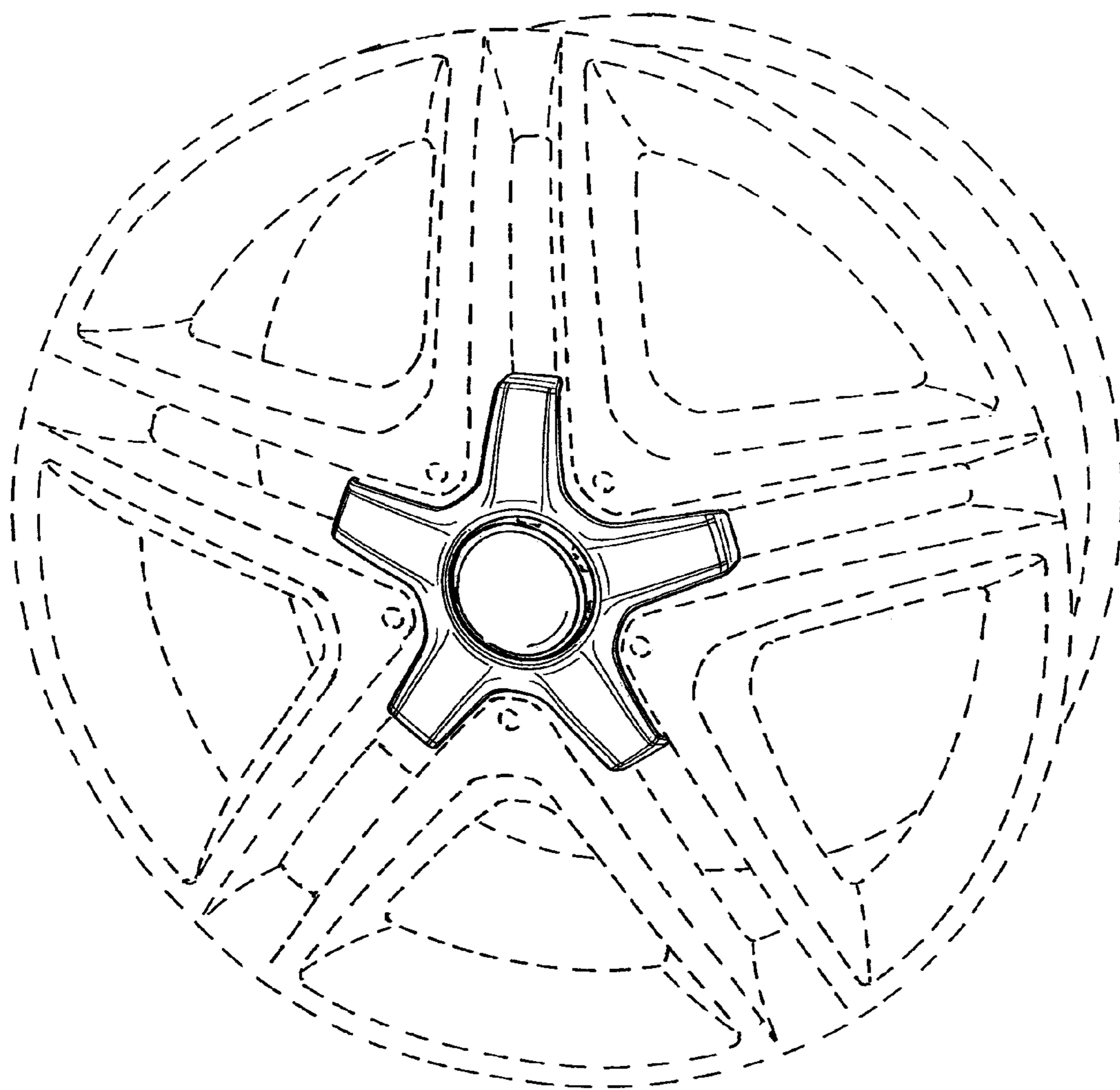

FIG. 6