



US00D747670S

(12) **United States Design Patent**  
**Chung et al.**

(10) **Patent No.:** **US D747,670 S**  
(45) **Date of Patent:** **\*\* Jan. 19, 2016**

(54) **CARRIER HOUSING**  
(71) Applicant: **American Axle & Manufacturing, Inc.**,  
Detroit, MI (US)  
(72) Inventors: **Chih-Hung Chung**, Detroit, MI (US);  
**Dajun Zuo**, Detroit, MI (US); **Adrian**  
**M. Lenczewski**, Detroit, MI (US);  
**Robert Chisholm**, Detroit, MI (US);  
**Brian Demos**, Detroit, MI (US)

(73) Assignee: **American Axle & Manufacturing, Inc.**,  
Detroit, MI (US)

(\*\*) Term: **14 Years**

(21) Appl. No.: **29/496,287**

(22) Filed: **Jul. 11, 2014**

(51) **LOC (10) Cl.** ..... **12-16**

(52) **U.S. Cl.**  
USPC ..... **D12/160**

(58) **Field of Classification Search**  
USPC ..... D12/160; 280/47.15, 124.156, 157,  
280/165; 180/348-349, 378, 905  
CPC ..... F16H 48/00; F16H 57/0483  
See application file for complete search history.

(56) **References Cited**

**U.S. PATENT DOCUMENTS**

1,950,034	A *	3/1934	Mulford	.....	B60K 17/16 184/13.1
3,041,890	A *	7/1962	O'Brien	.....	B60B 35/163 74/607
D345,127	S *	3/1994	Stenglein	.....	D12/126
5,486,757	A *	1/1996	Easley	.....	G01P 3/488 29/434
6,216,658	B1	4/2001	Pierro et al.		
7,229,087	B2 *	6/2007	Nicolas	.....	B60G 7/003 280/124.13
D600,167	S *	9/2009	Maguire	.....	D12/126
7,669,330	B1 *	3/2010	McGean	.....	F16H 57/037 29/893.1
D631,799	S *	2/2011	Maguire	.....	D12/126
8,036,863	B2	10/2011	Schankin et al.		

8,087,323	B2	1/2012	Hedman et al.		
8,657,316	B1 *	2/2014	Bowers	.....	B60G 9/003 180/352
9,074,678	B1 *	7/2015	Marsh, Jr.	.....	B60B 35/122
9,109,689	B2 *	8/2015	Khatavkar	.....	F16H 57/037
2004/0162148	A1	8/2004	Krugman et al.		
2006/0094558	A1 *	5/2006	Petruska	.....	F16H 57/029 475/220
2015/0087461	A1 *	3/2015	Jackson	.....	F16H 48/08 475/160

**OTHER PUBLICATIONS**

SAE Technical Paper Series 2003-01-3427 entitled "Design Optimization Method for CAD Structural Components", dated Nov. 10, 2003.

\* cited by examiner

*Primary Examiner* — Michael A Pratt

(74) *Attorney, Agent, or Firm* — Harness, Dickey & Pierce, P.L.C.

(57) **CLAIM**

The ornamental design for a carrier housing, as shown and described.

**DESCRIPTION**

FIG. 1 is a rear perspective view of a first carrier housing constructed in accordance with the teachings of the present disclosure;

FIG. 2 is a rear side elevation view of the carrier housing of FIG. 1;

FIG. 3 is a right side elevation view of the carrier housing of FIG. 1;

FIG. 4 is a front side elevation view of the carrier housing of FIG. 1;

FIG. 5 is a left side elevation view of the carrier housing of FIG. 1;

FIG. 6 is a top plan view of the carrier housing of FIG. 1;

FIG. 7 is a bottom plan view of the carrier housing of FIG. 1;

FIG. 8 is a section view taken along the line 8-8 of FIG. 2;

FIG. 9 is a section view taken along the line 9-9 of FIG. 2;

FIG. 10 is a section view taken along the line 10-10 of FIG. 3;

FIG. 11 is a section view taken along the line 11-11 of FIG. 2;

FIG. 12 is a section view taken along the line 12-12 of FIG. 3;

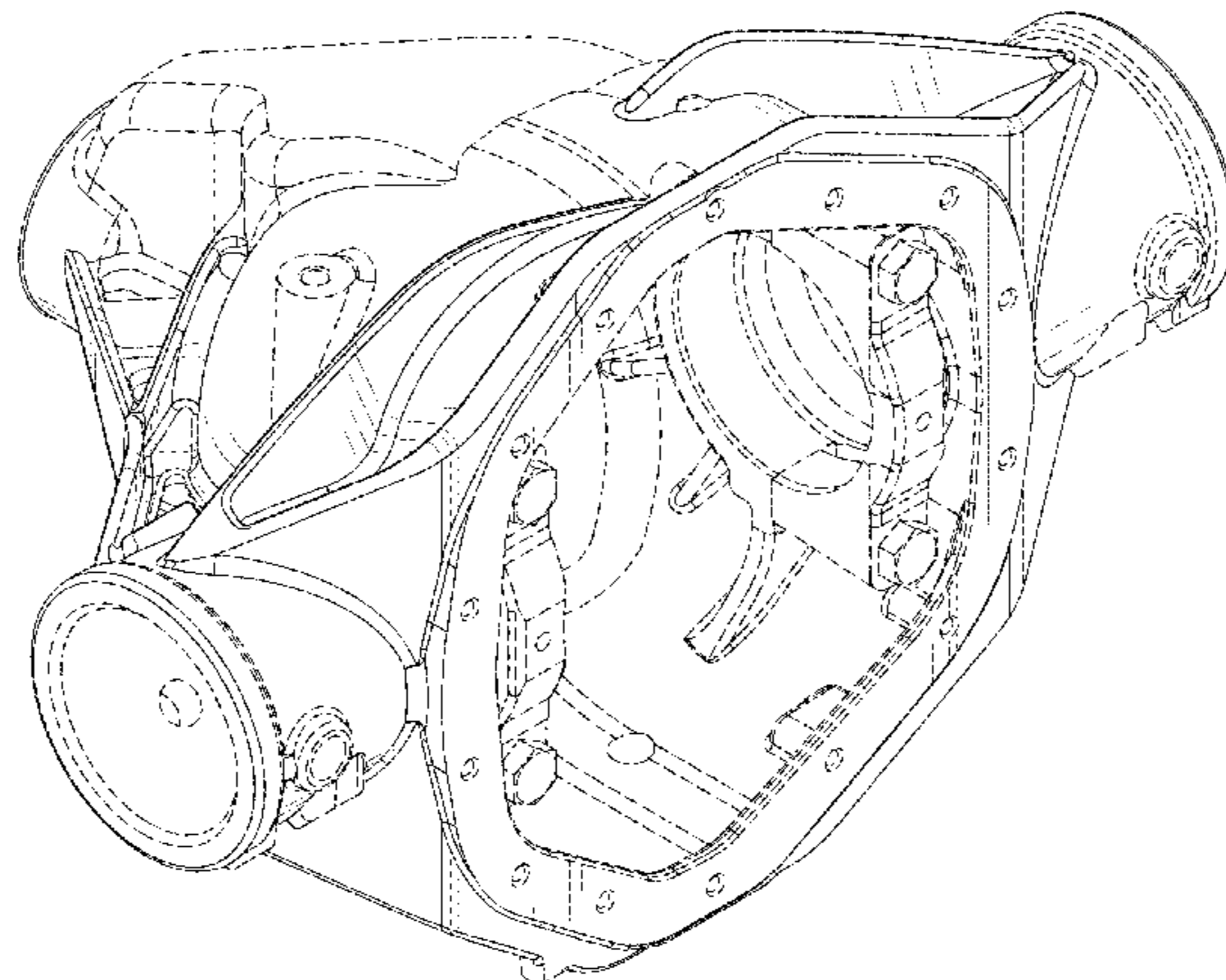

FIG. 13 is a section view taken along the line 13-13 of FIG. 3;  
FIG. 14 is a section view taken along the line 14-14 of FIG. 3;  
FIG. 15 is a rear perspective view of a second carrier housing constructed in accordance with the teachings of the present disclosure;

FIG. 16 is a rear side elevation view of the carrier housing of FIG. 15;

FIG. 17 is a right side elevation view of the carrier housing of FIG. 15;

FIG. 18 is a front side elevation view of the carrier housing of FIG. 15;

FIG. 19 is a left side elevation view of the carrier housing of FIG. 15;

FIG. 20 is a top plan view of the carrier housing of FIG. 15;

FIG. 21 is a bottom plan view of the carrier housing of FIG. 15;

FIG. 22 is a section view taken along the line 8-8 of FIG. 16;

FIG. 23 is a section view taken along the line 9-9 of FIG. 16;

FIG. 24 is a section view taken along the line 10-10 of FIG. 17;

FIG. 25 is a section view taken along the line 11-11 of FIG. 16;

FIG. 26 is a section view taken along the line 12-12 of FIG. 17;

FIG. 27 is a section view taken along the line 13-13 of FIG. 17; and,

FIG. 28 is a section view taken along the line 14-14 of FIG. 17.

Portions of the carrier housings that are shown in broken line form no part of the claimed design. Additionally, Applicant reserves the right to disclaim any portion or portions of the carrier housings that is/are shown in solid line and to claim any portion or portions of the carrier housings that is/are shown in broken line.

**1 Claim, 24 Drawing Sheets**

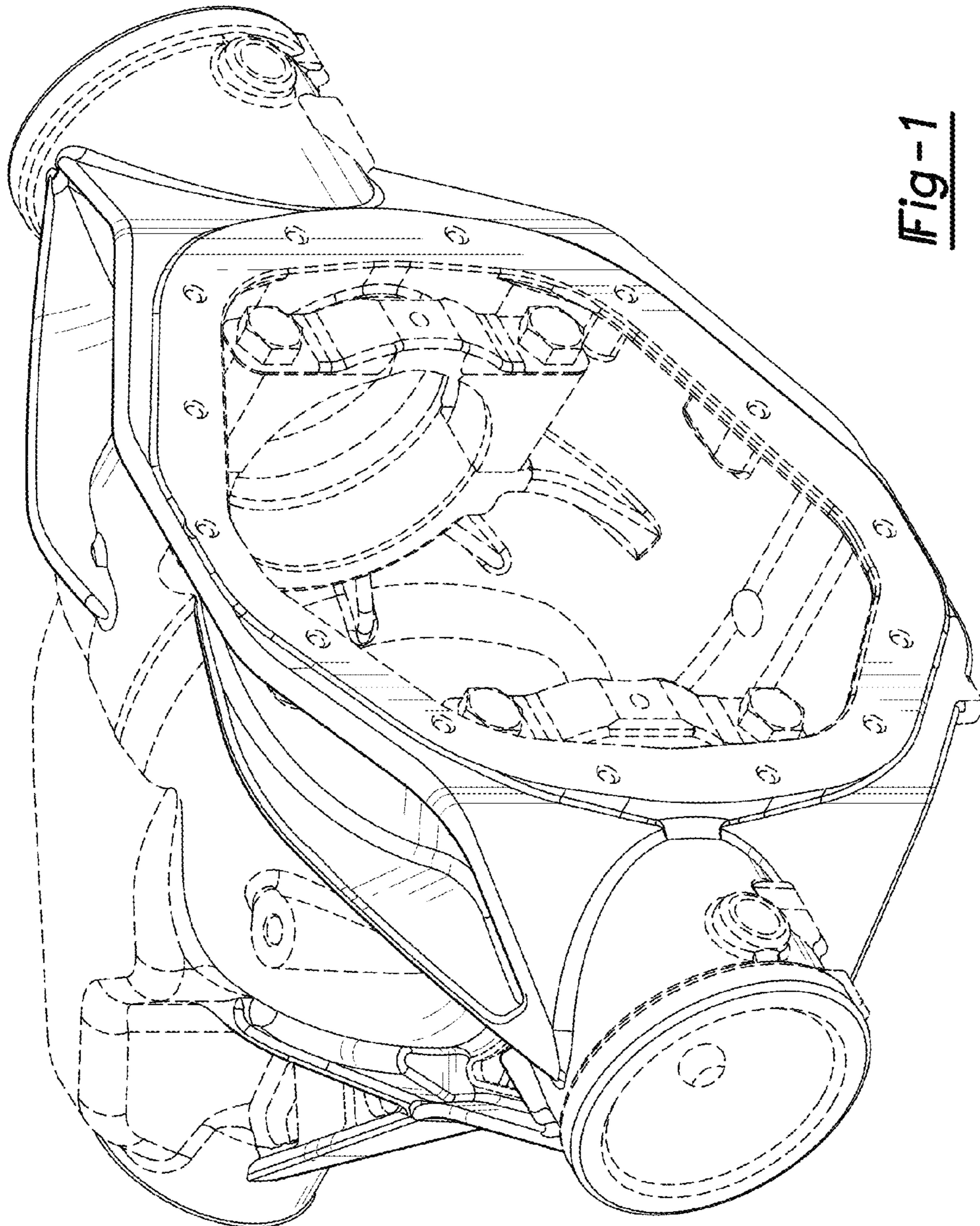

Fig-1

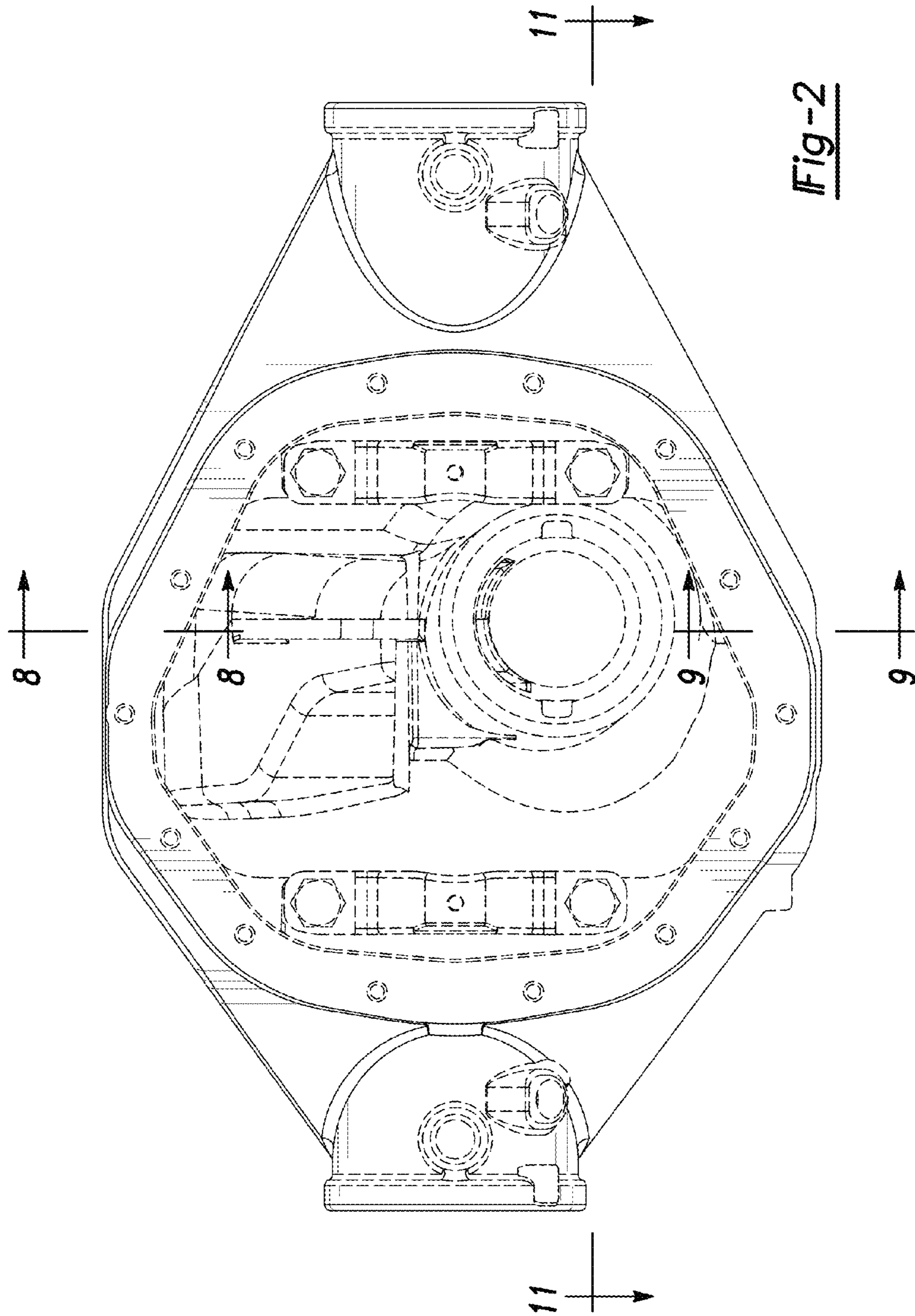
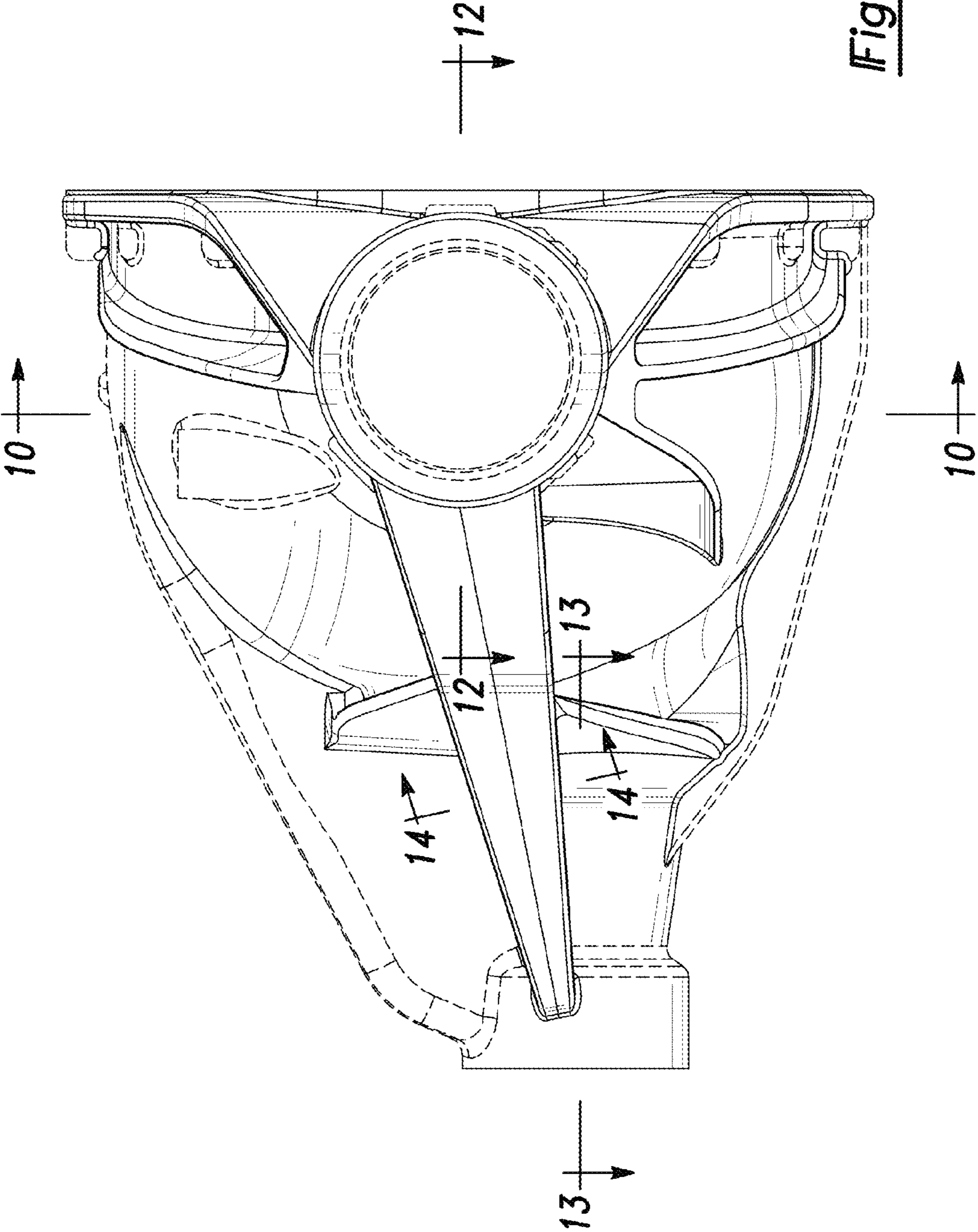

Fig-2



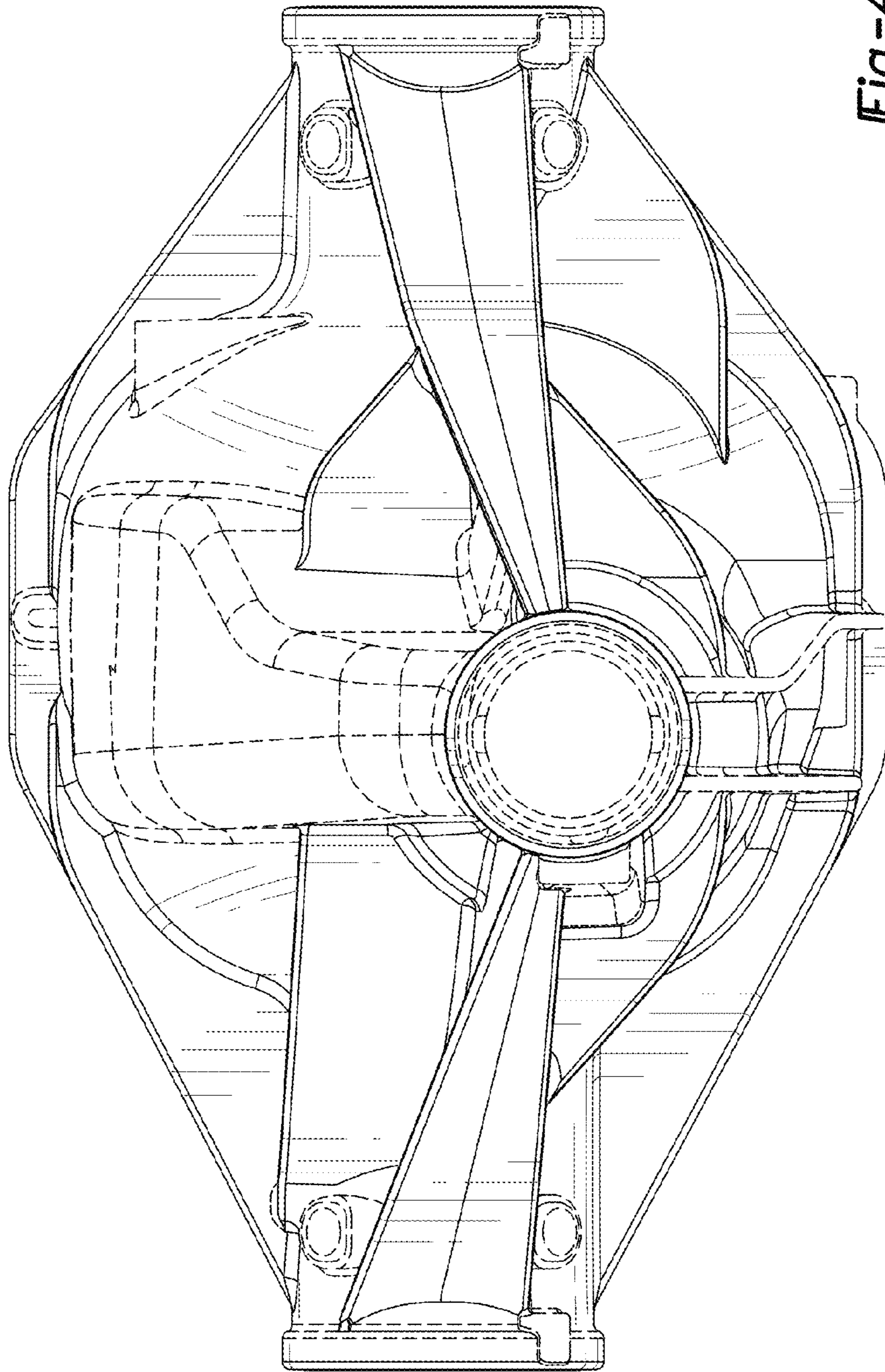

Fig-4

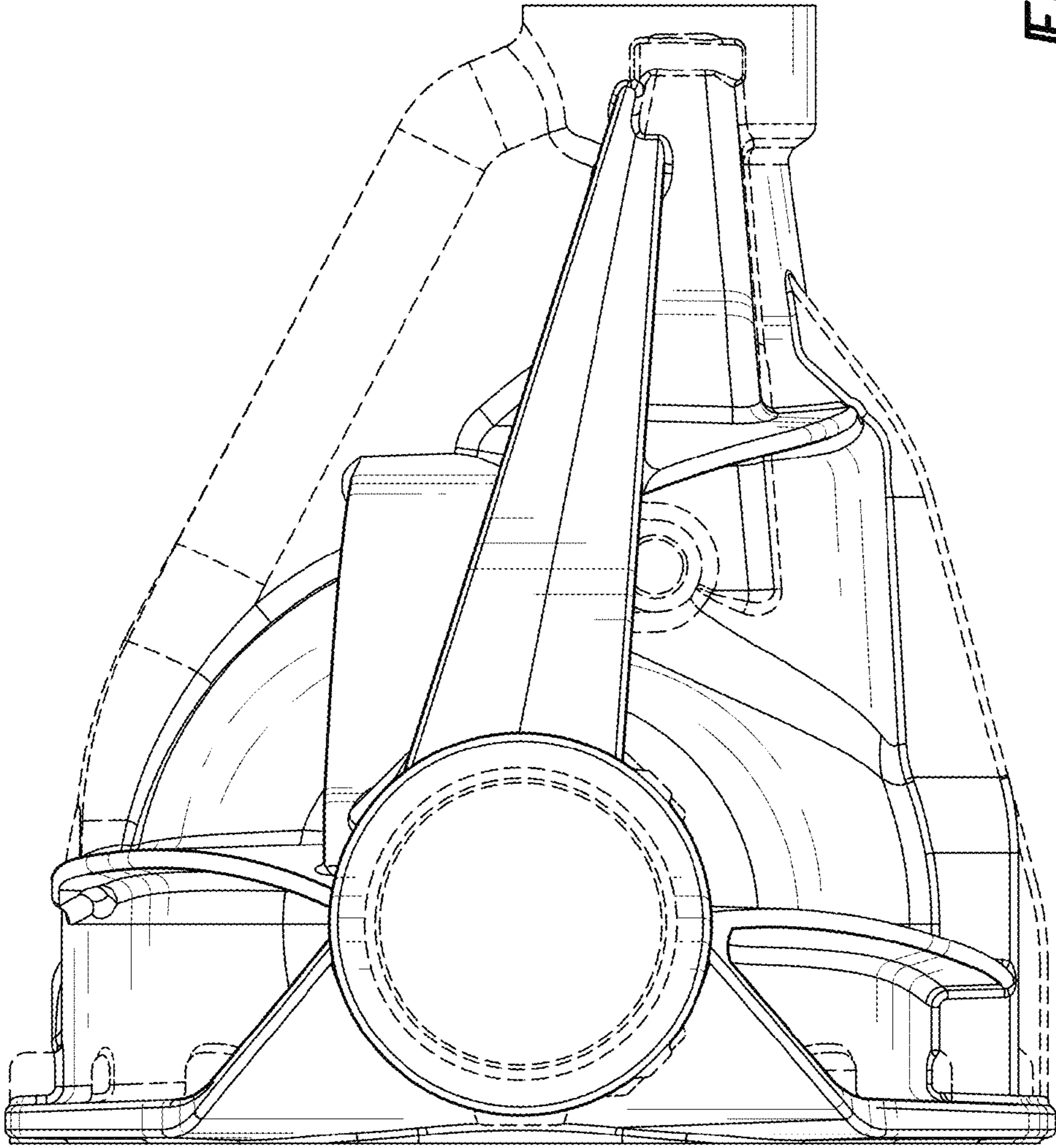

Fig-5

Fig-6

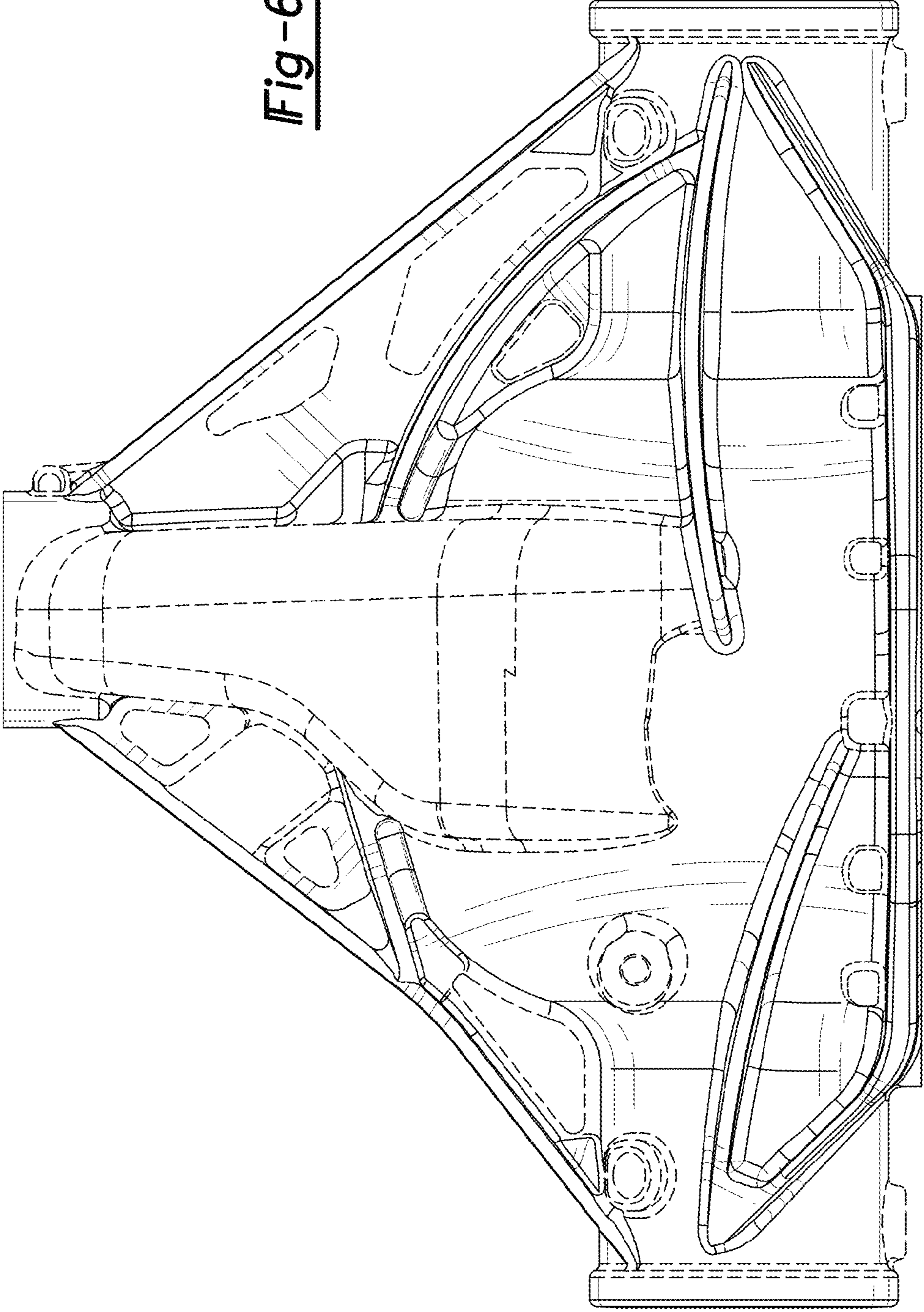
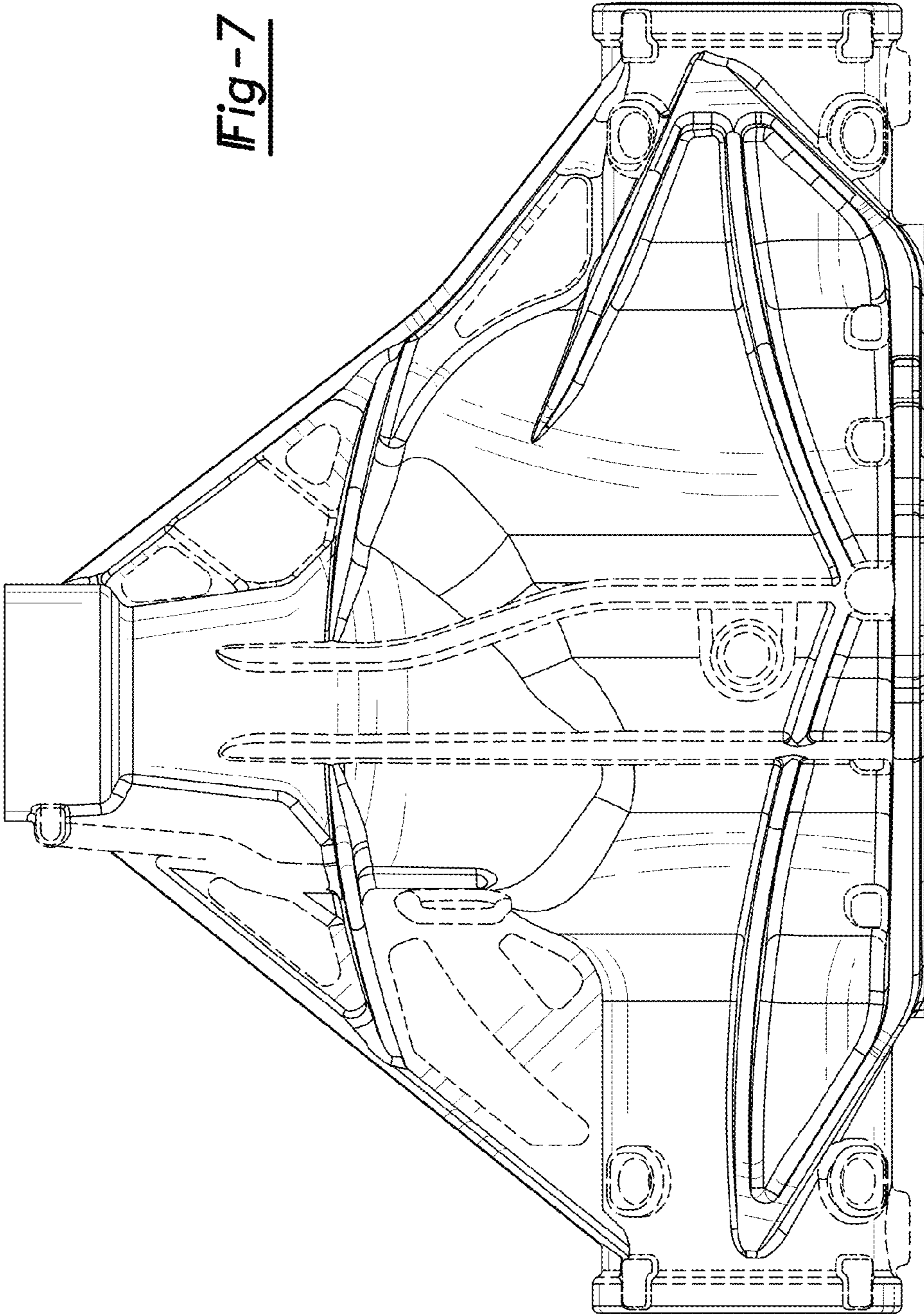



Fig-7



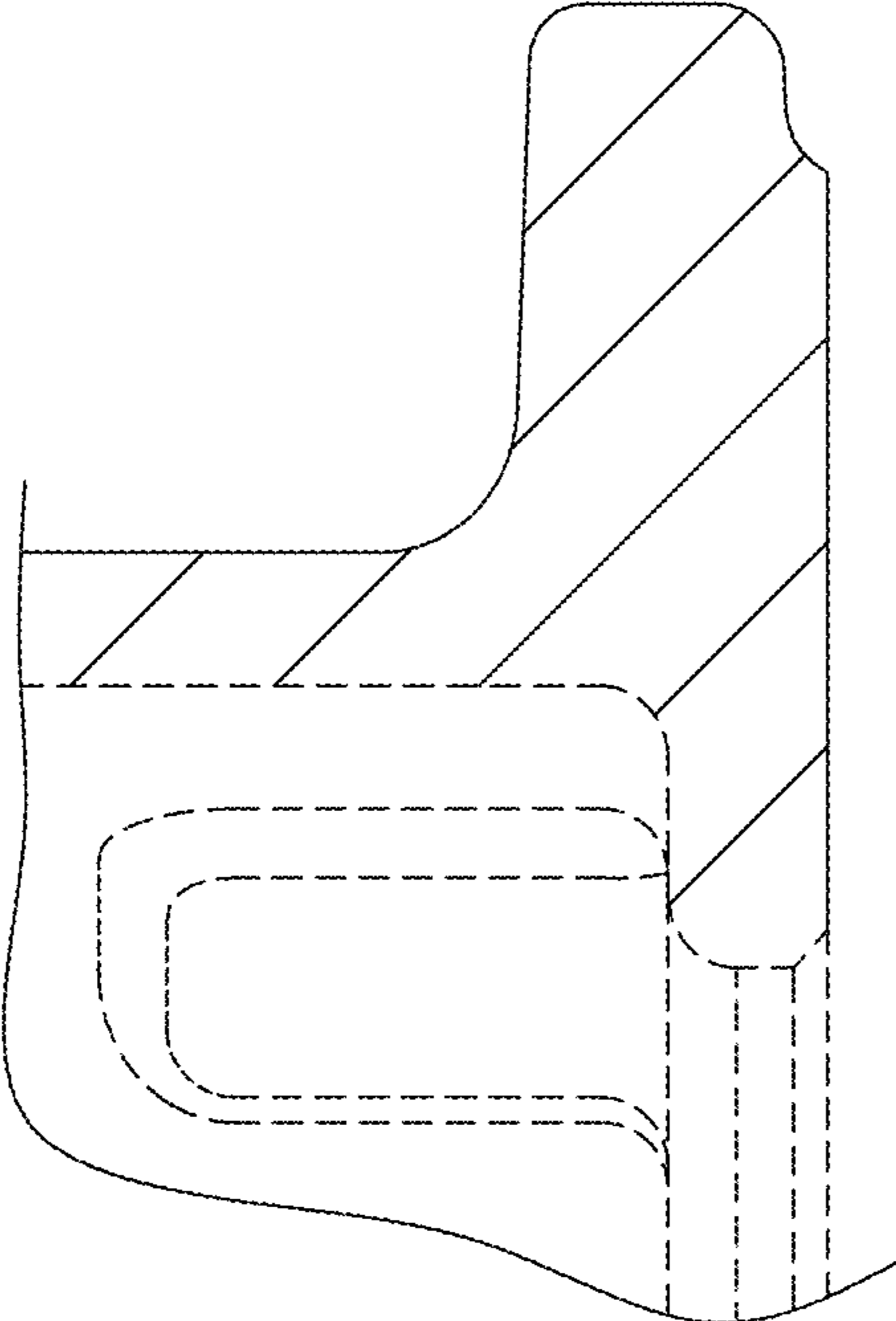

Fig-8

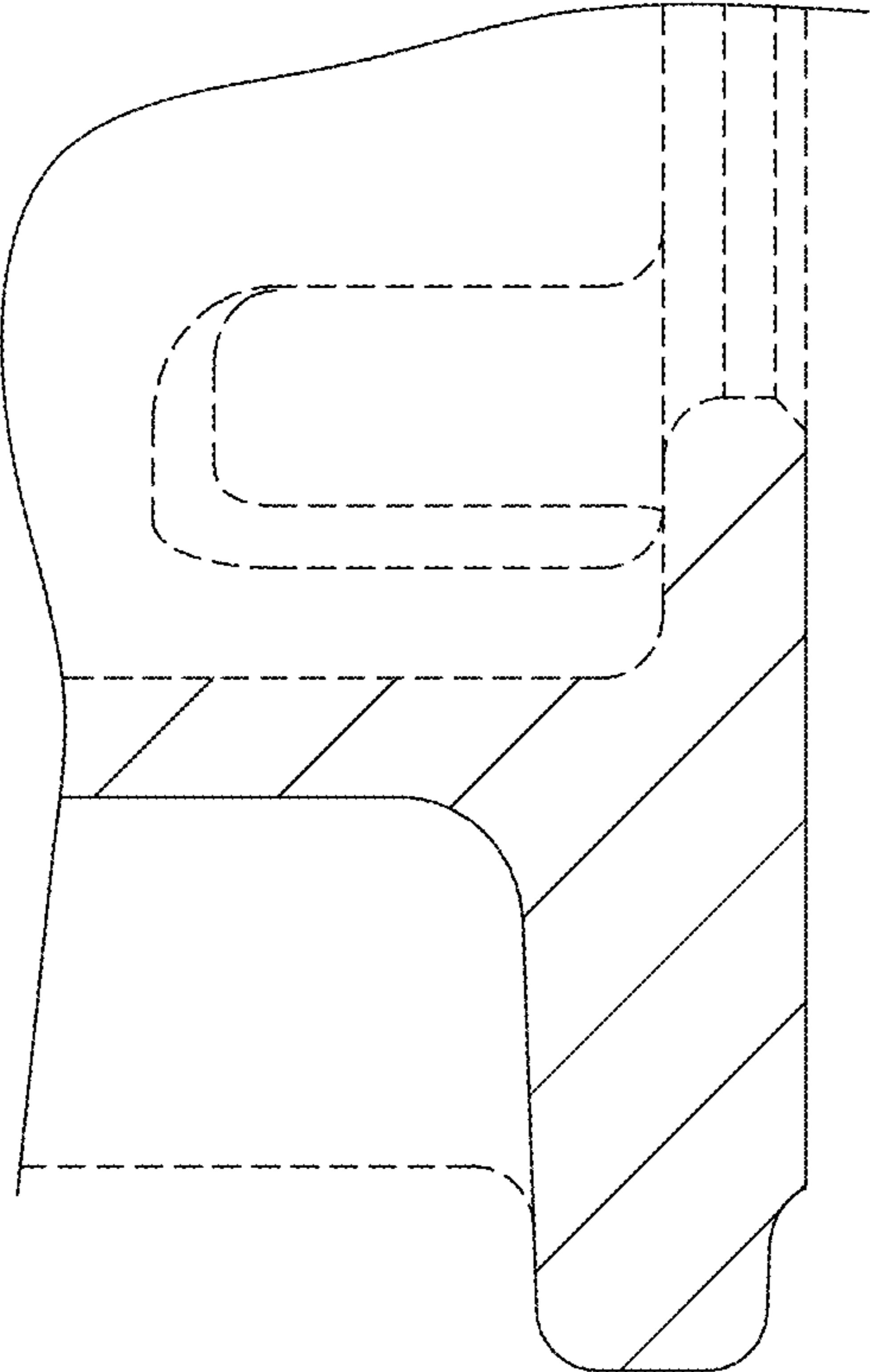

Fig-9

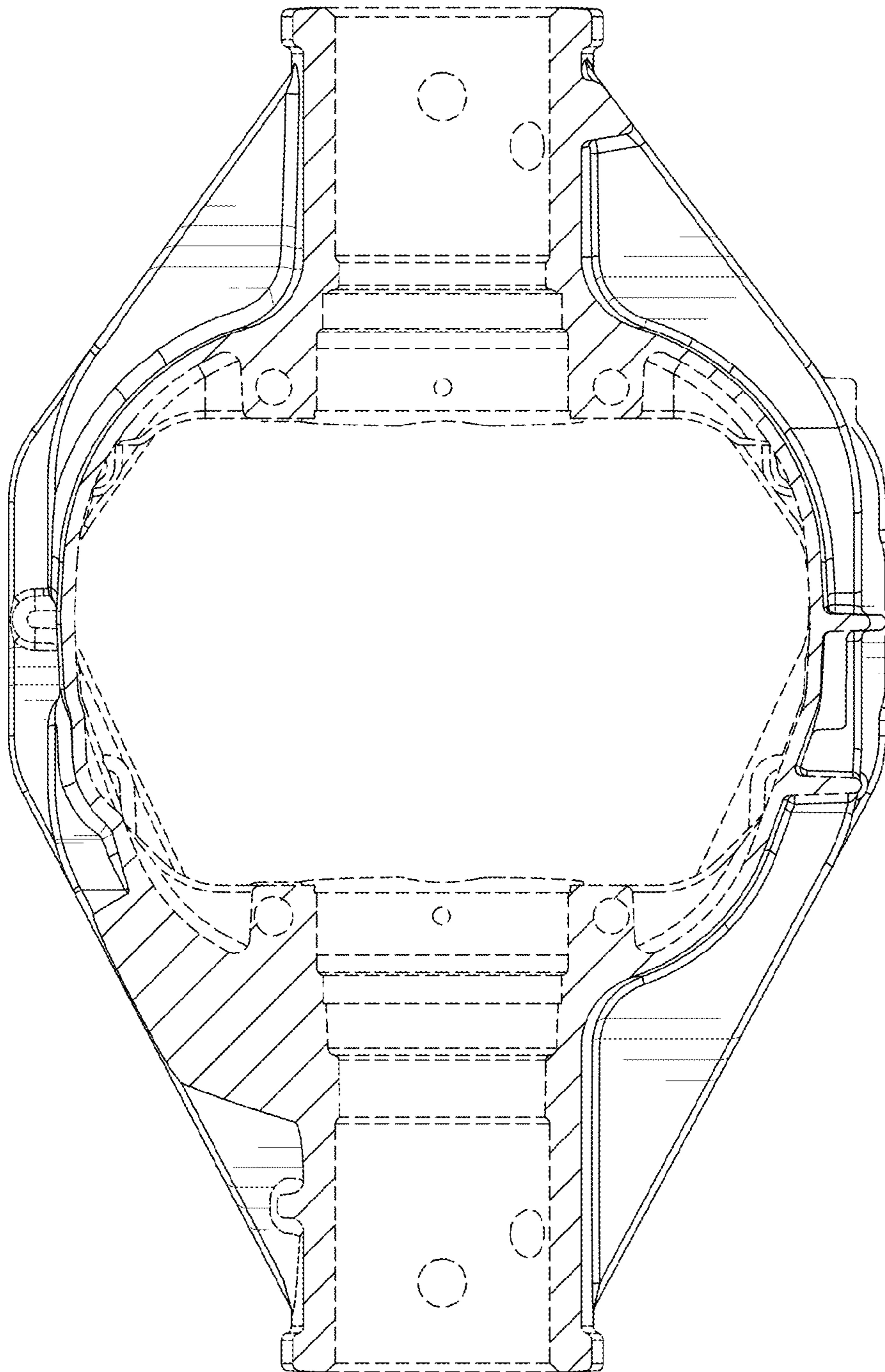

Fig-10

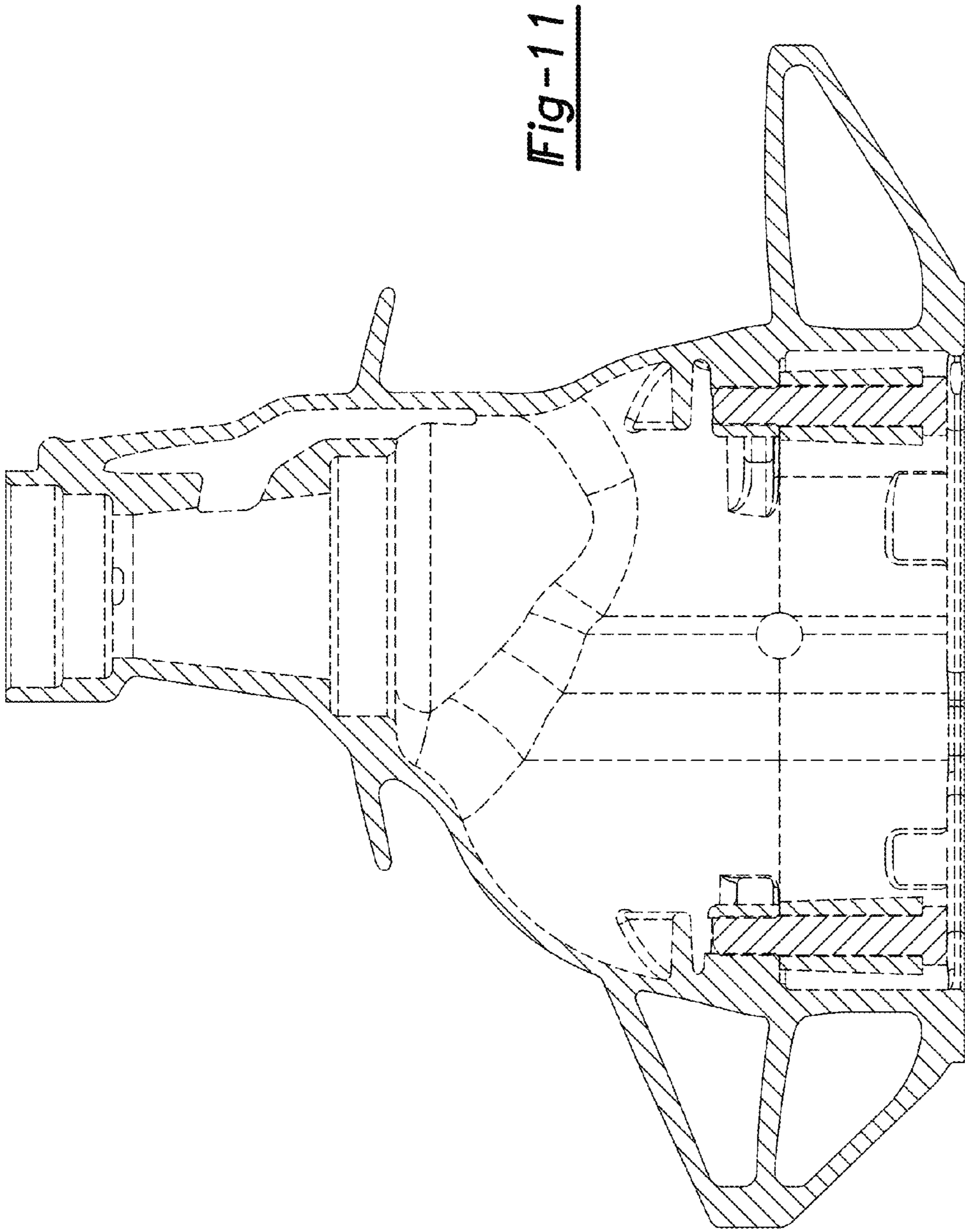

Fig-11

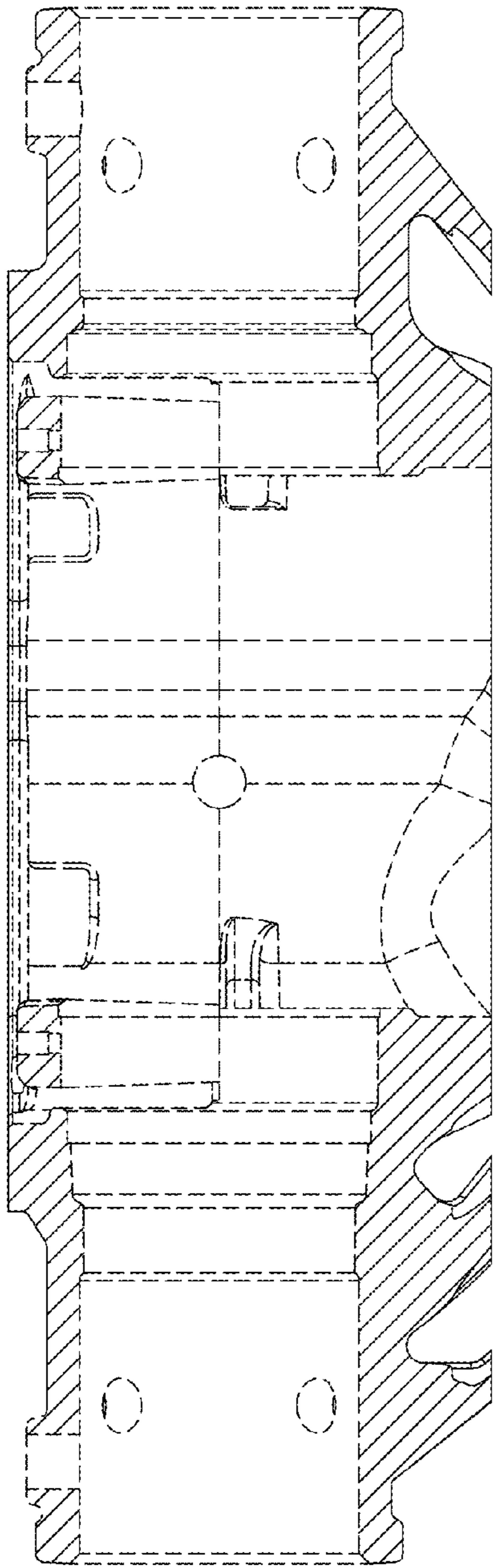

Fig-12

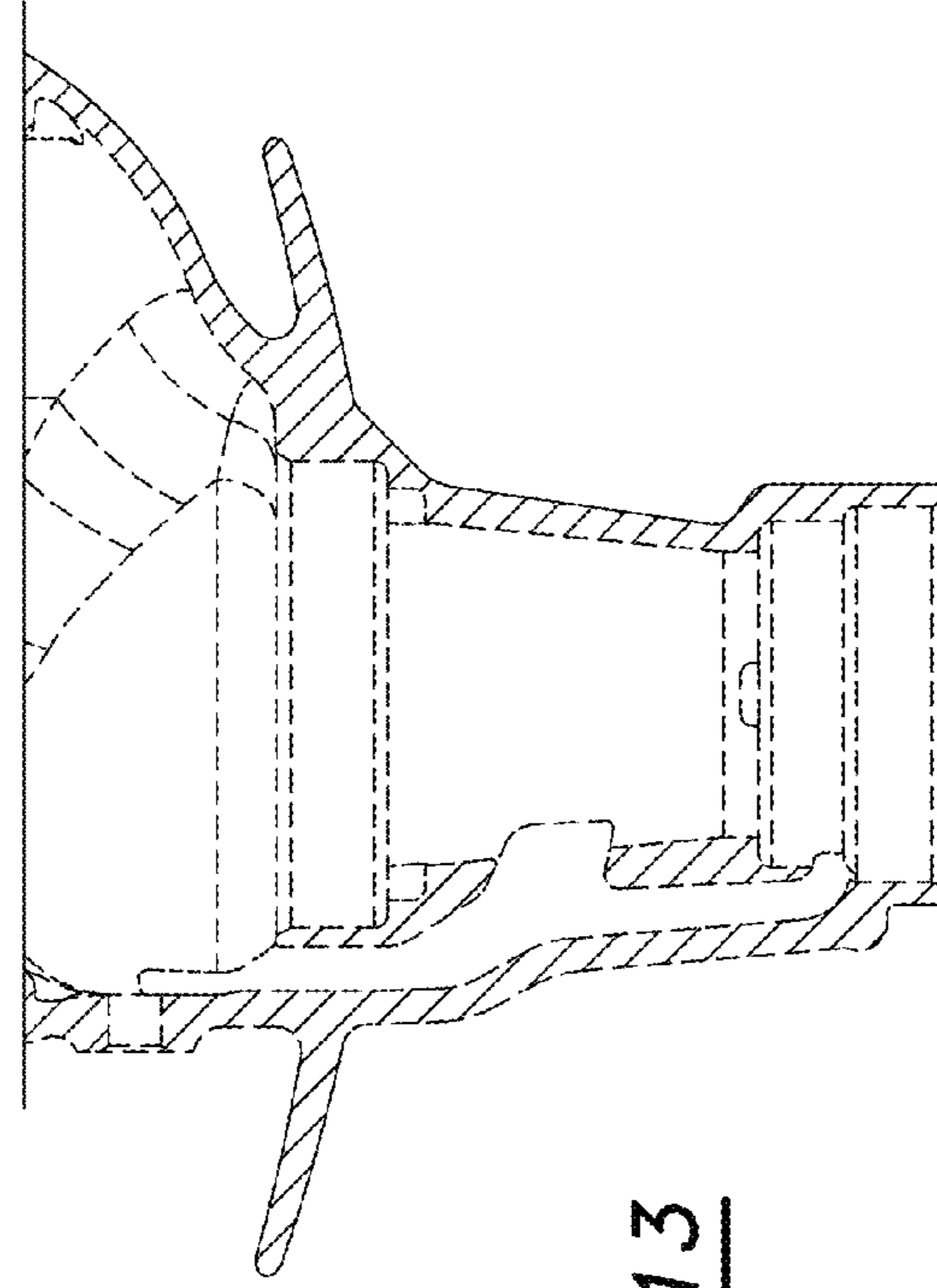

Fig-13

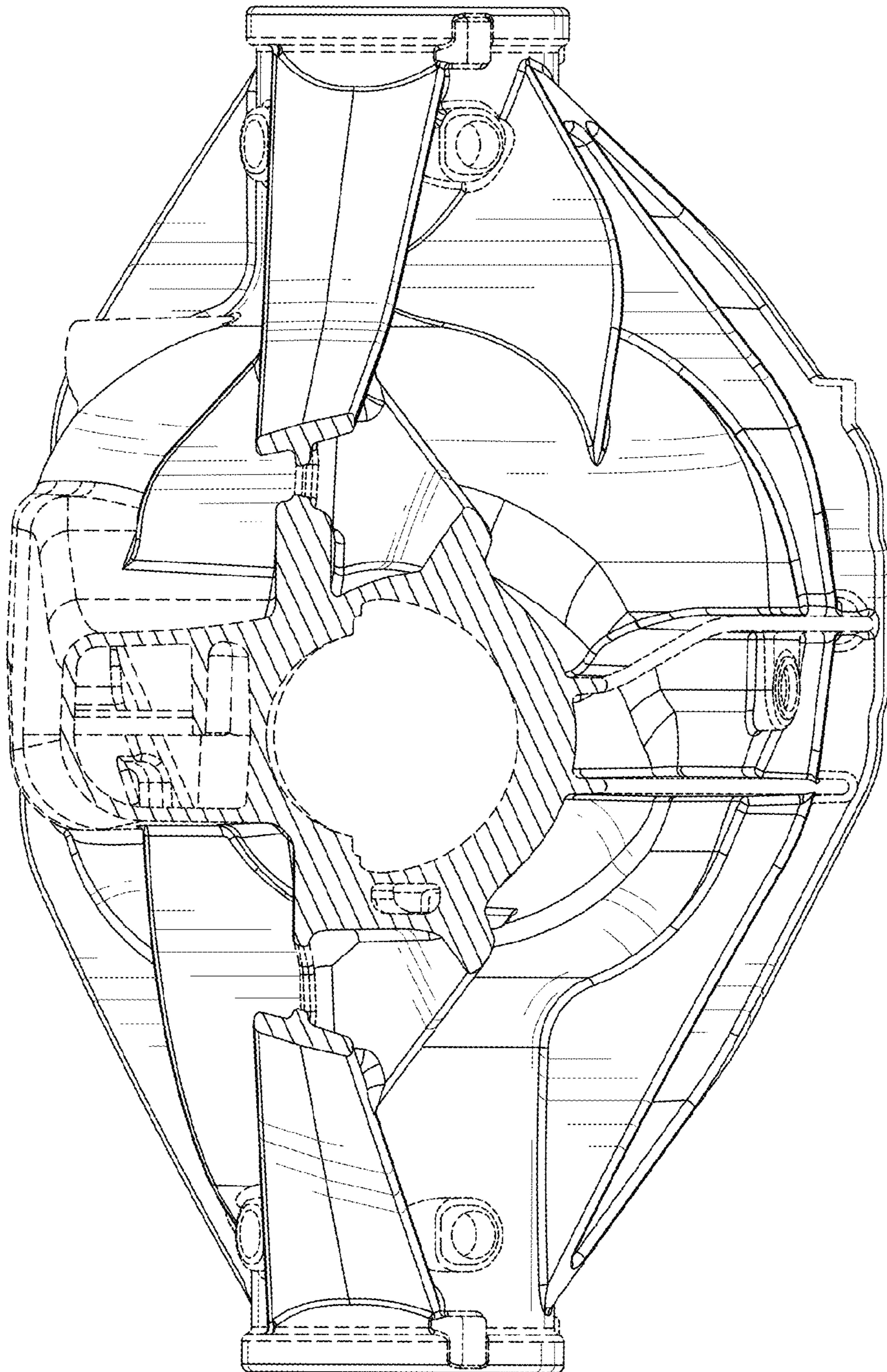

Fig-14

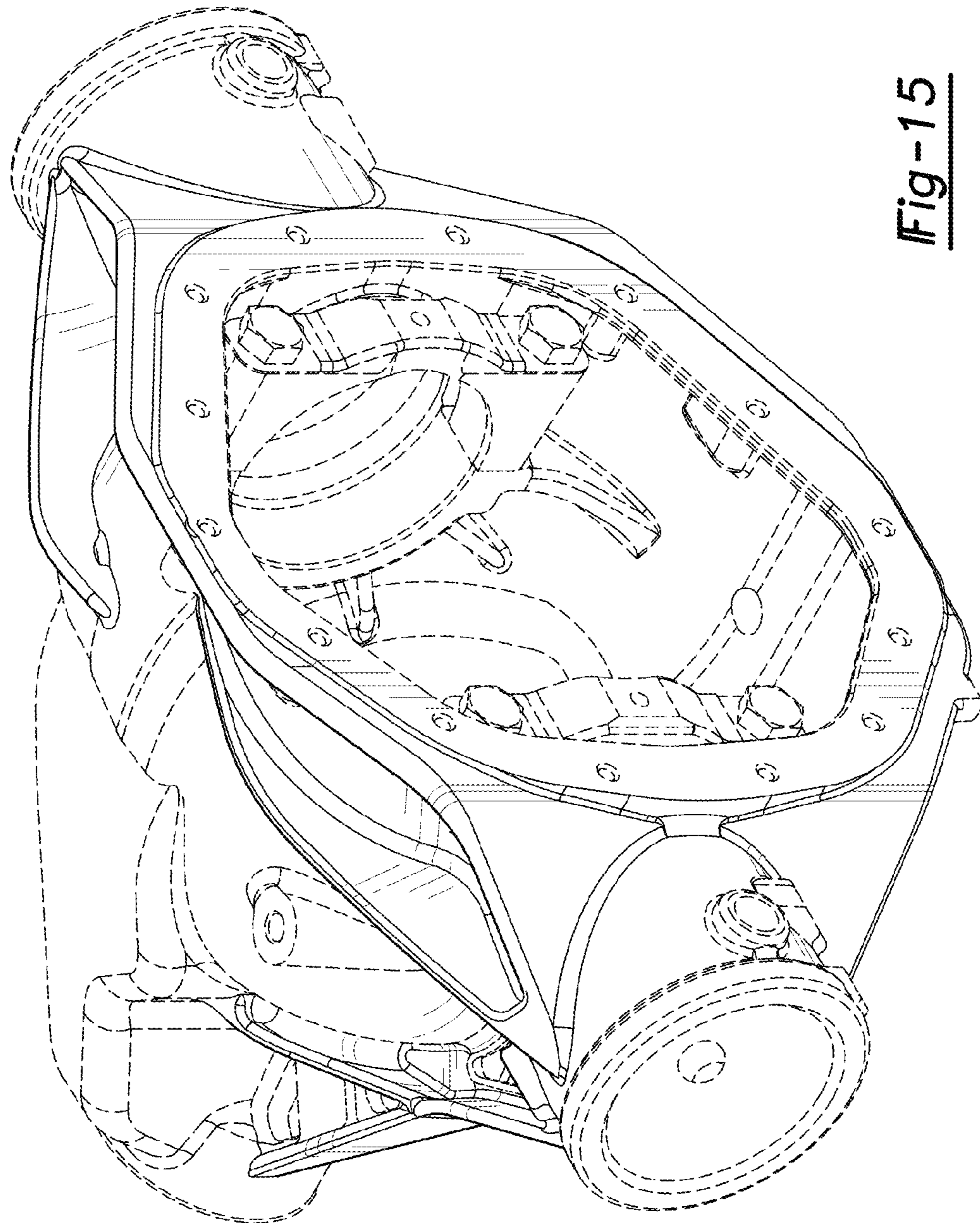

Fig-15

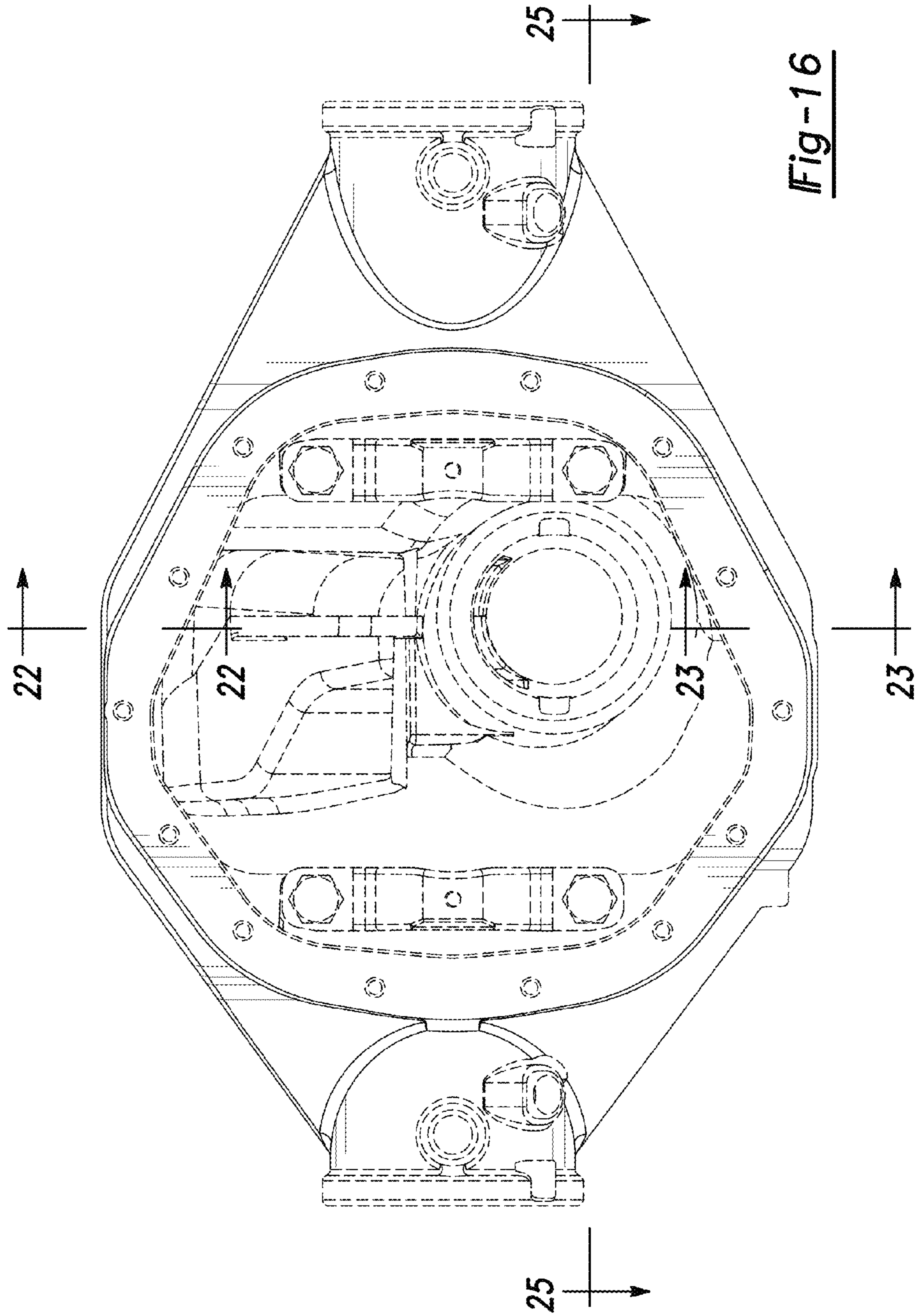

Fig-16



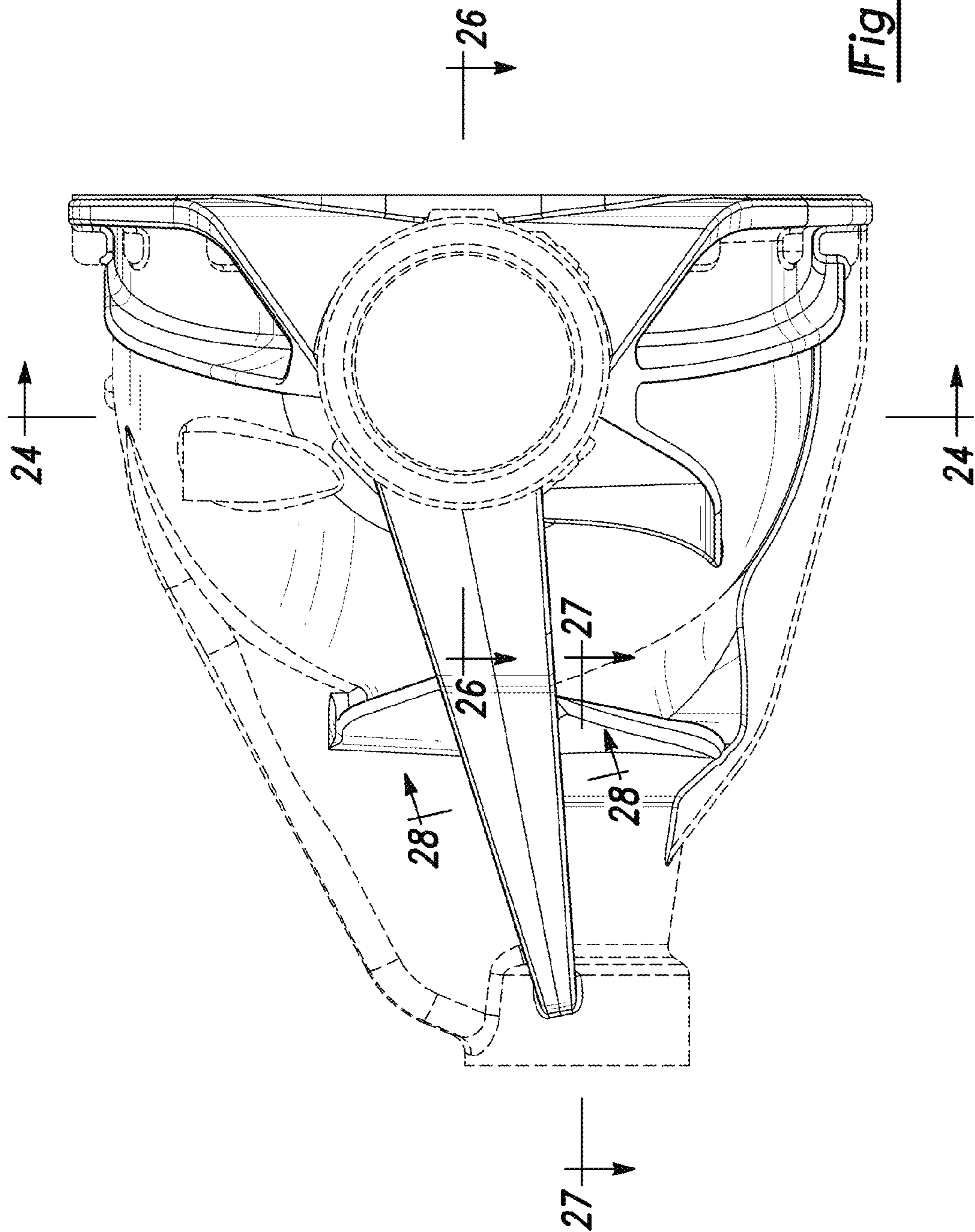

Fig-17

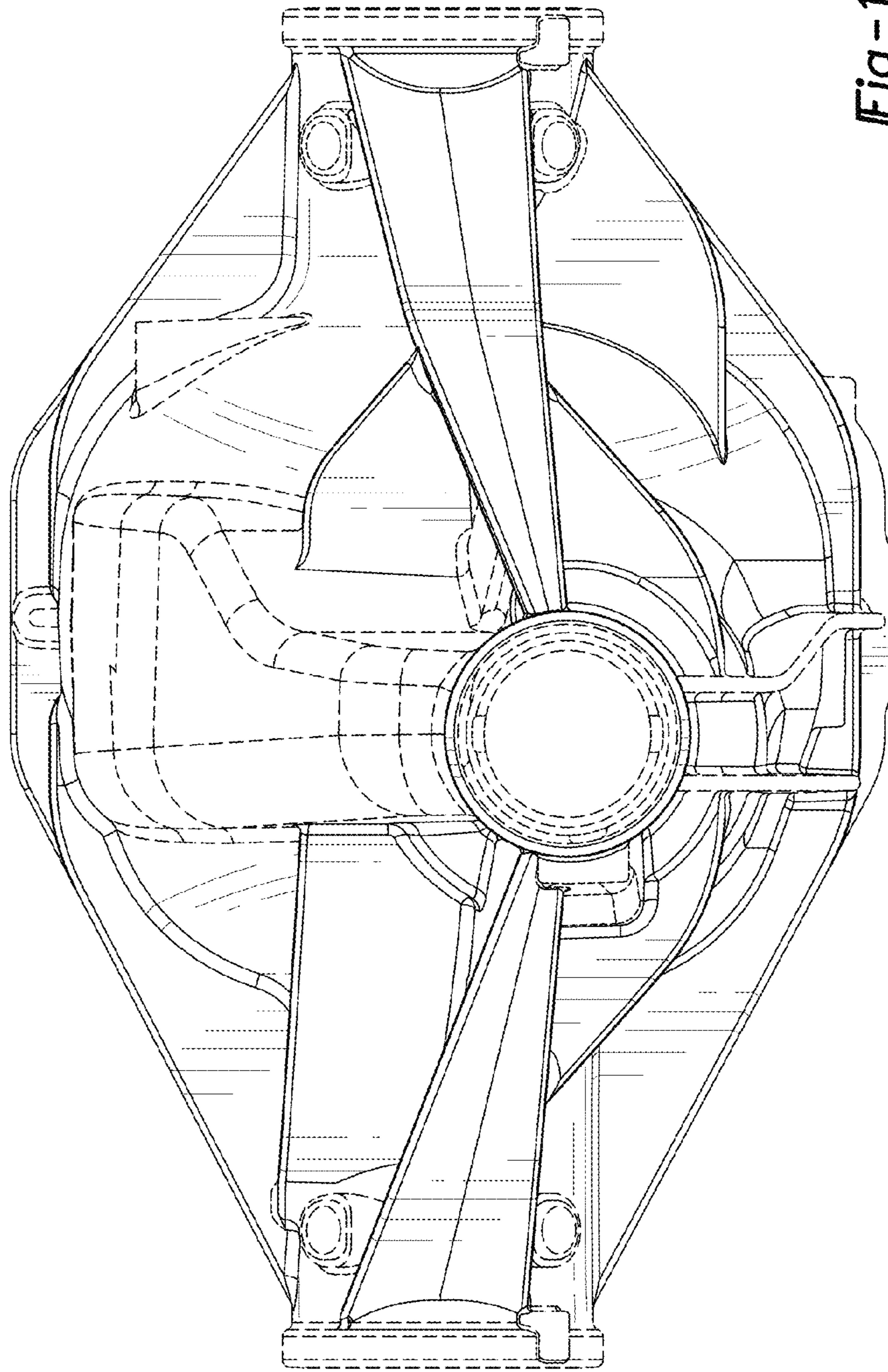

Fig-18

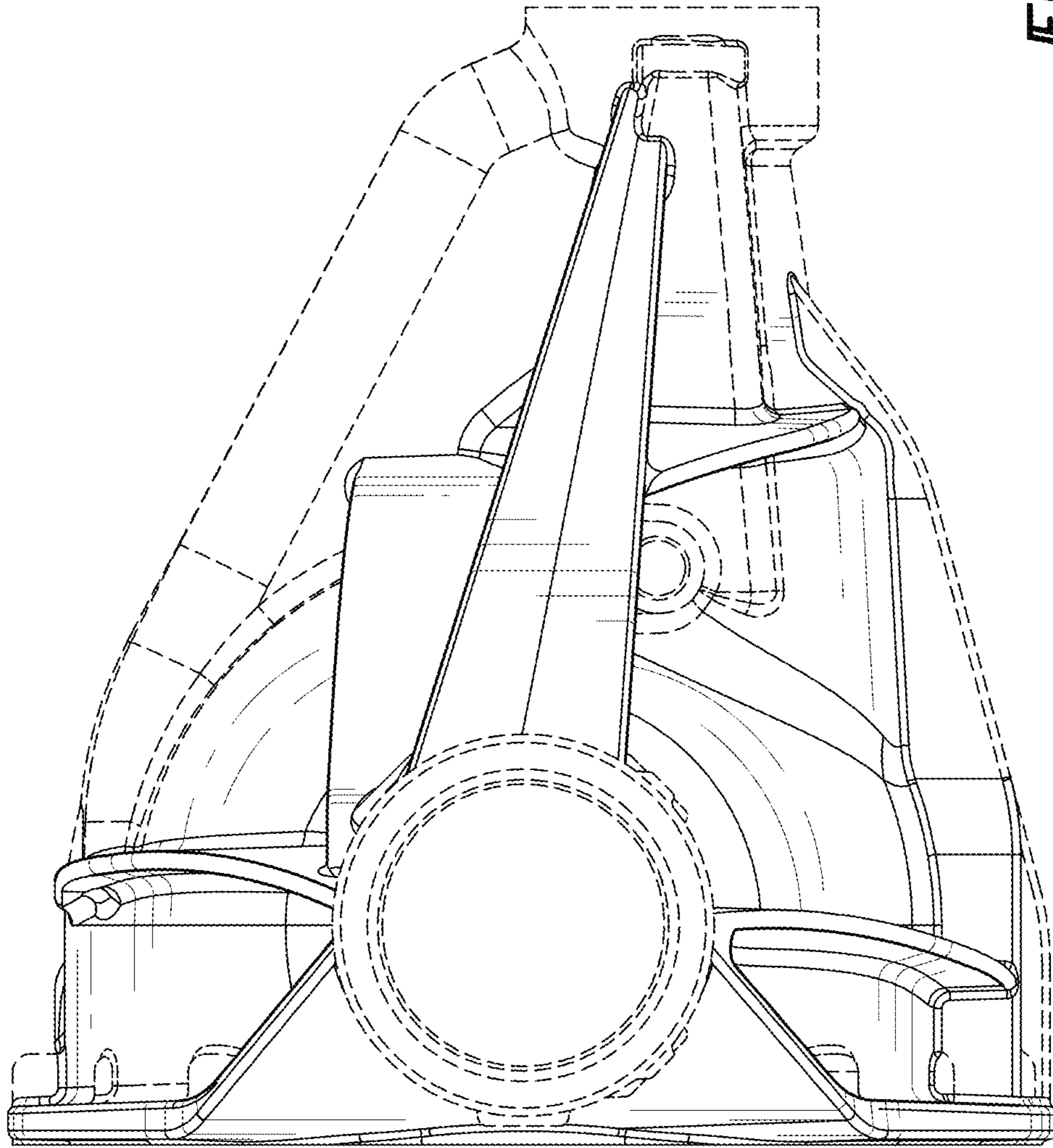

Fig-19

Fig-20

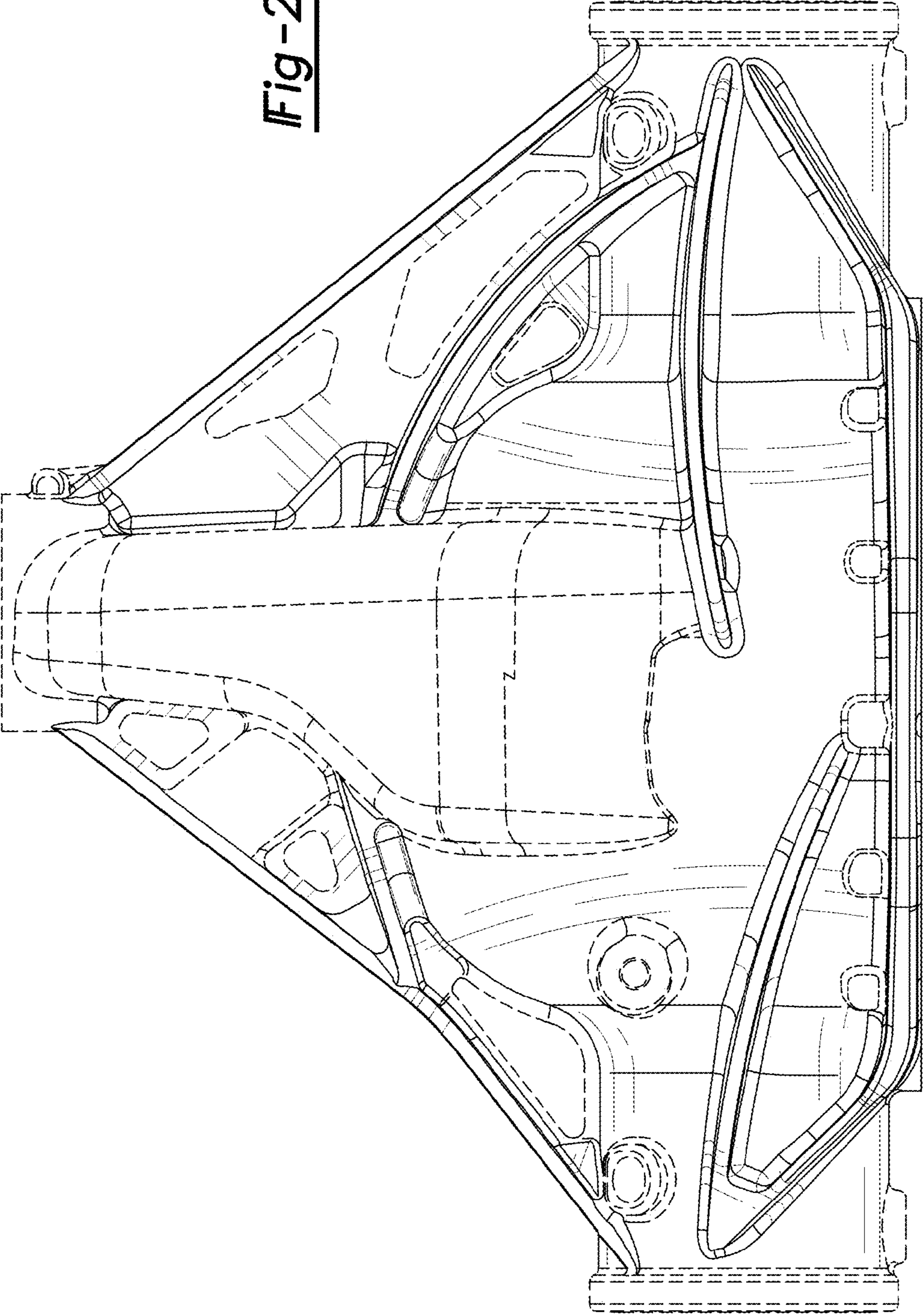
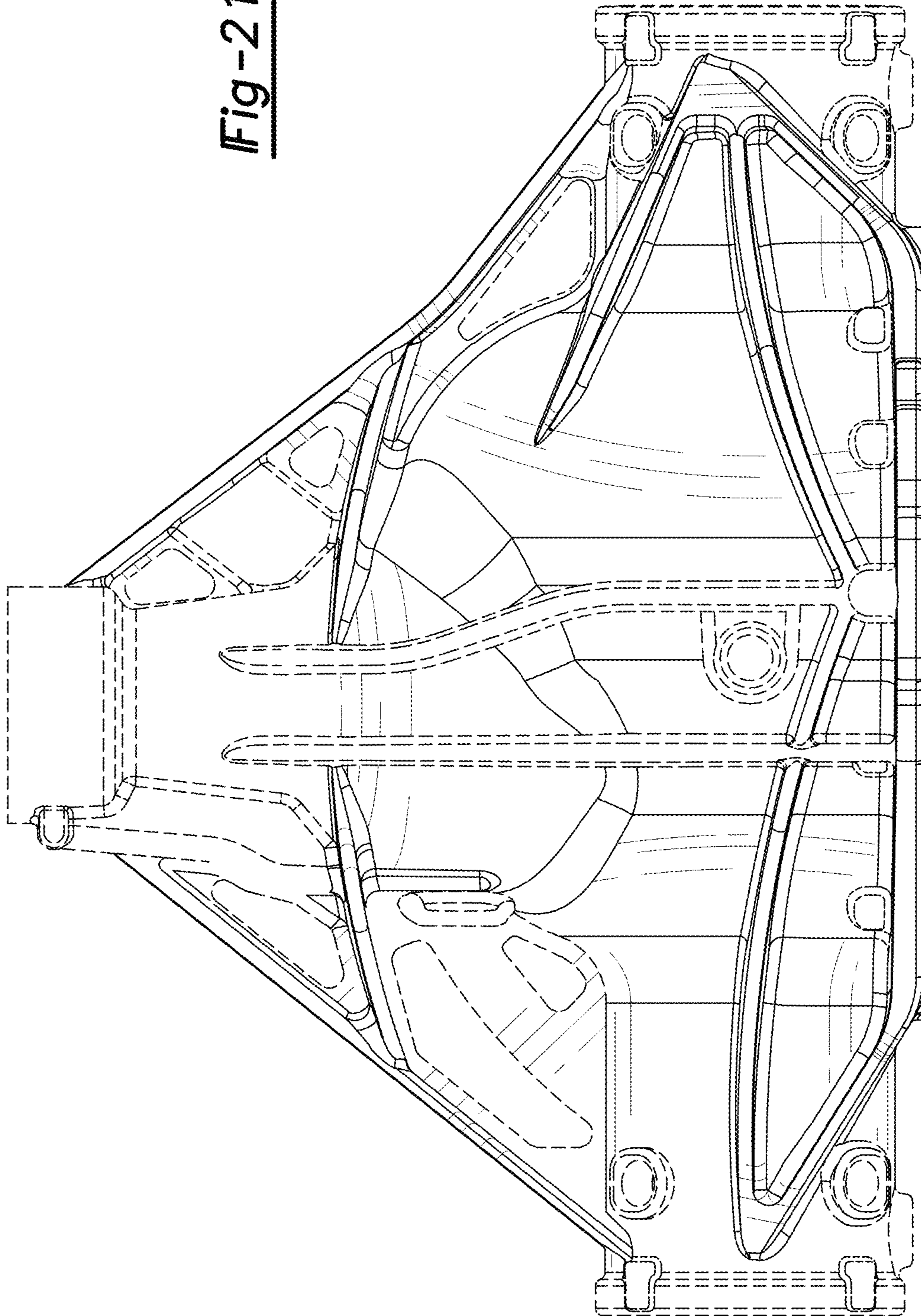

Fig-21



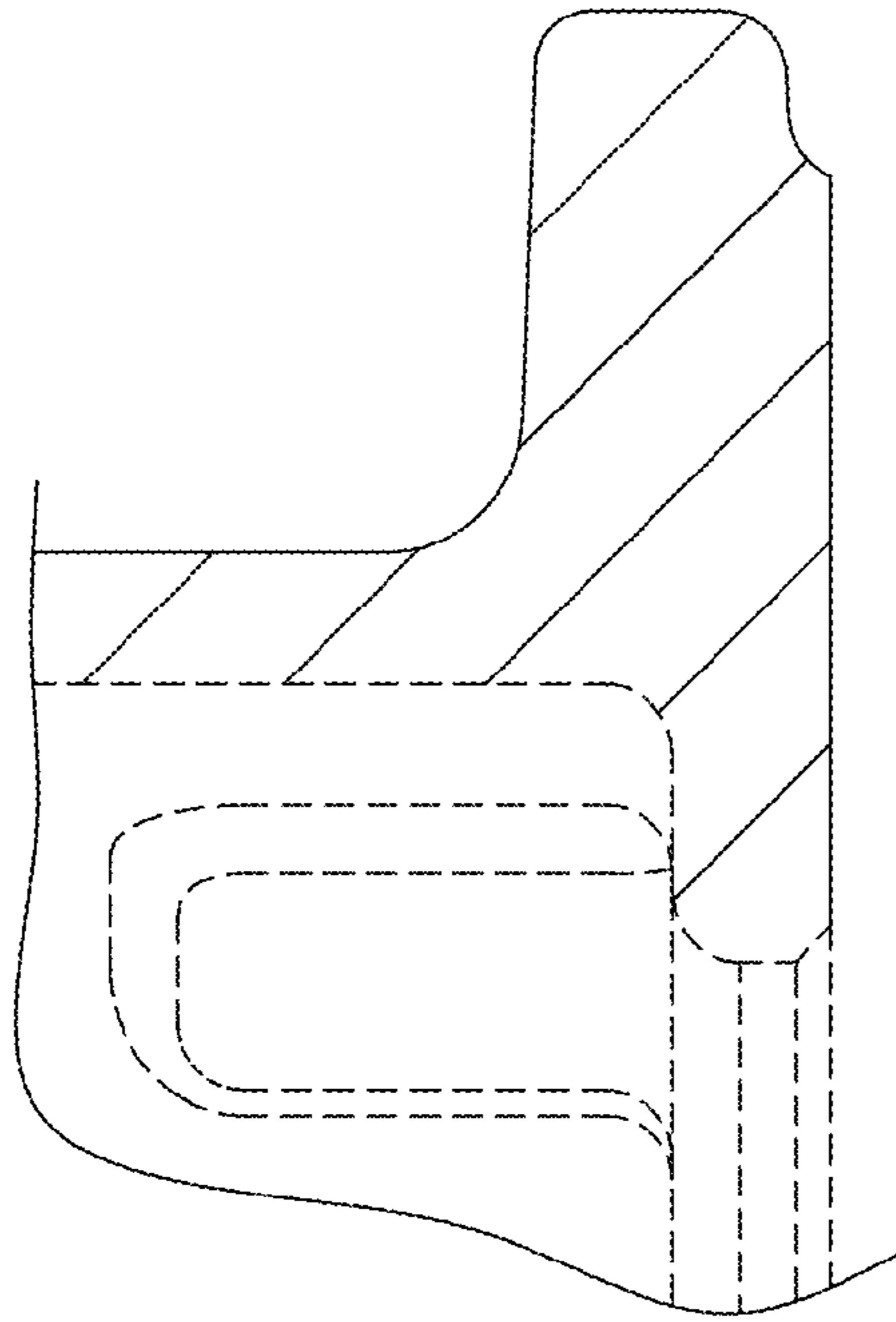

Fig-22

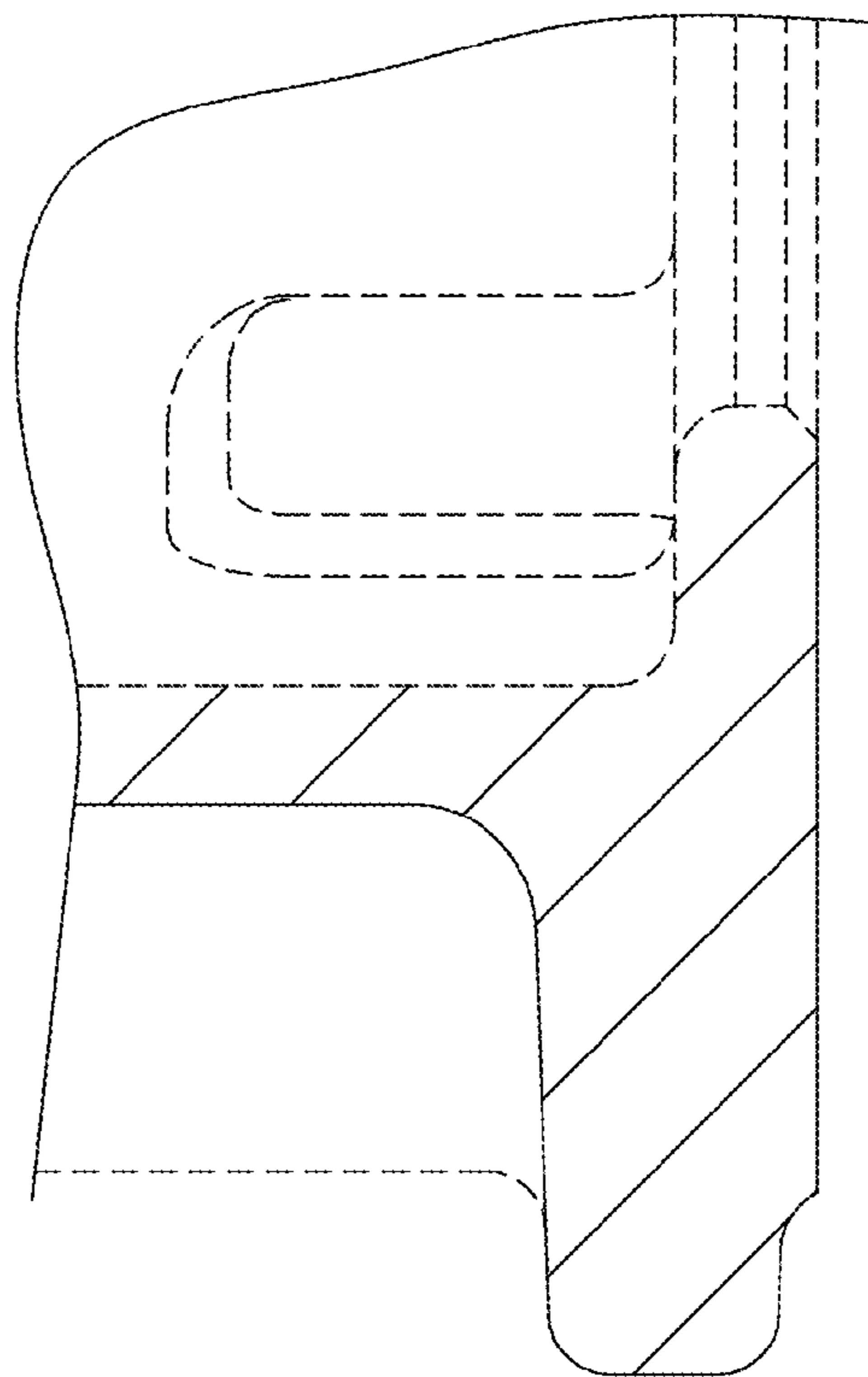

Fig-23

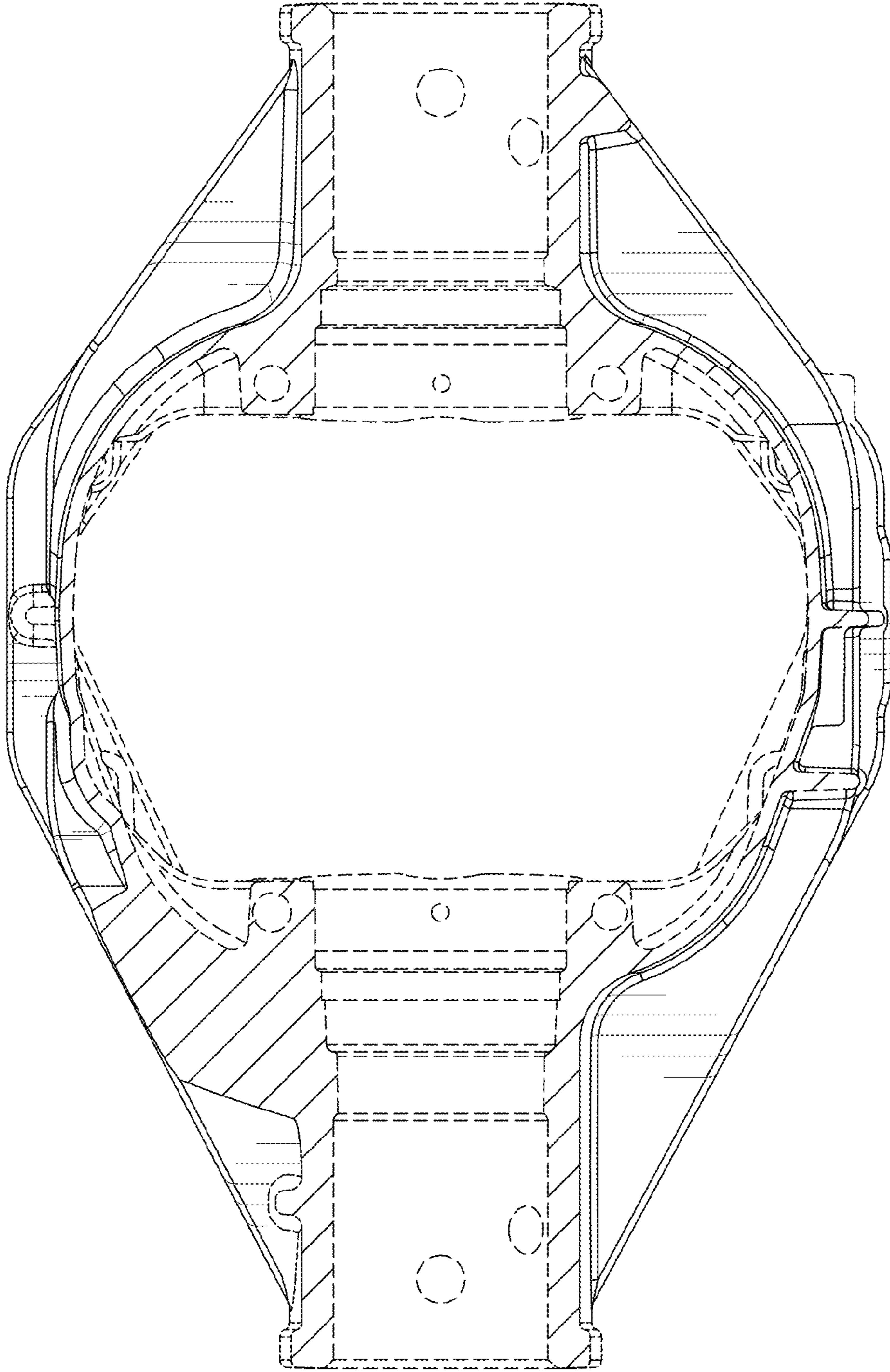
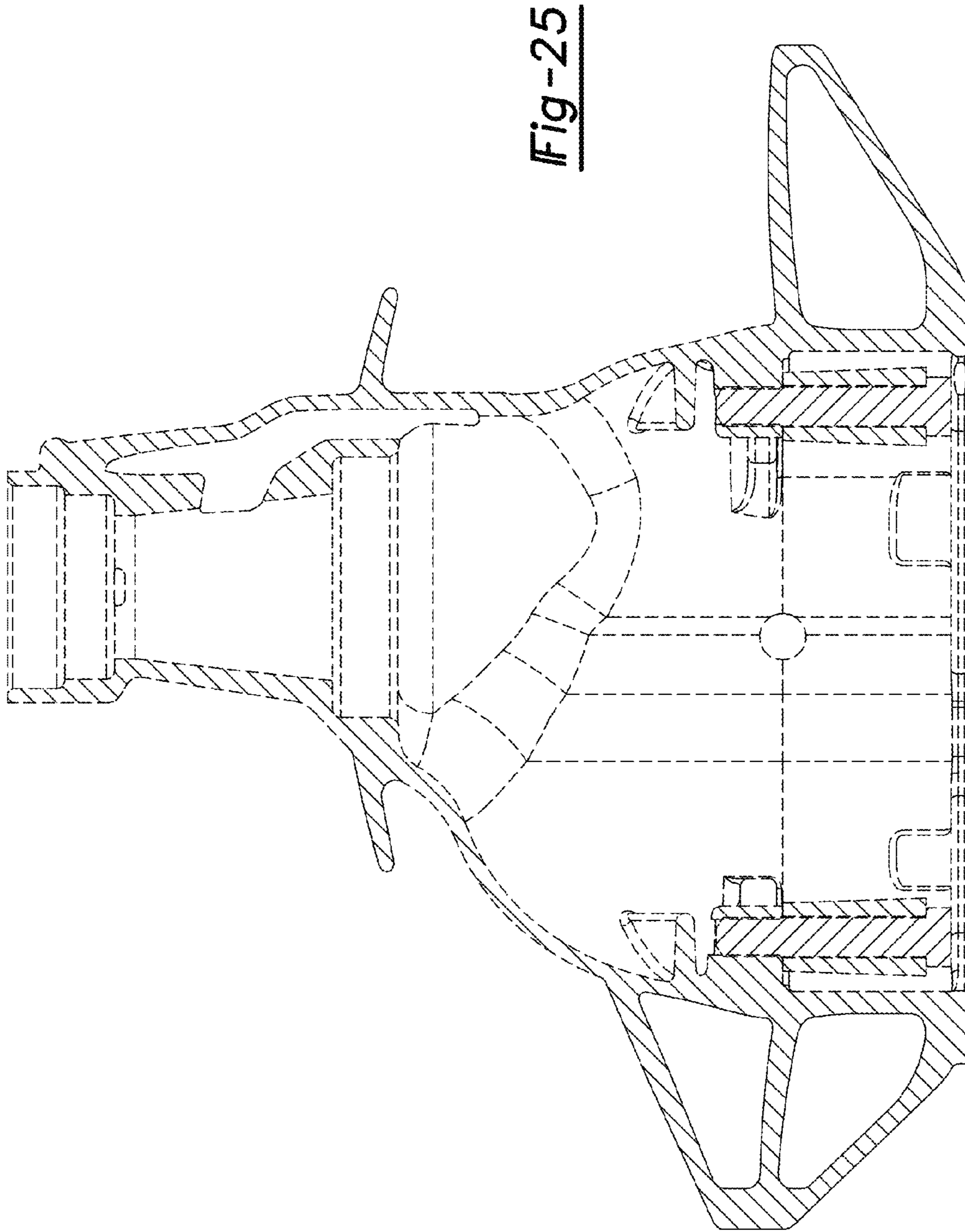

Fig-24





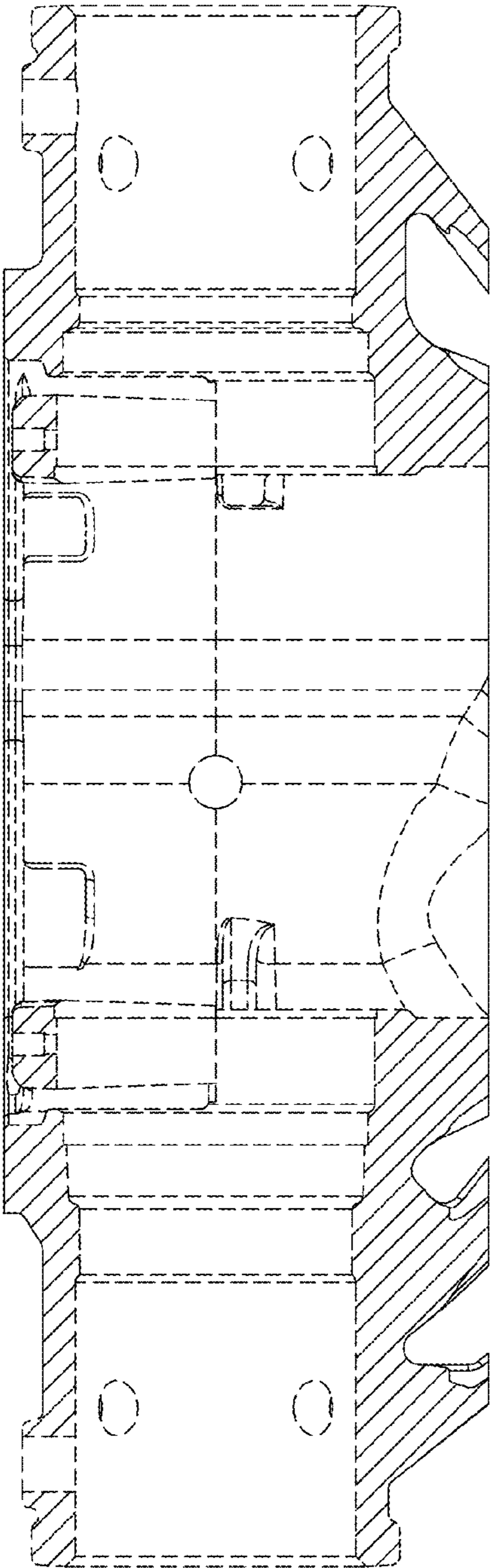

Fig-26

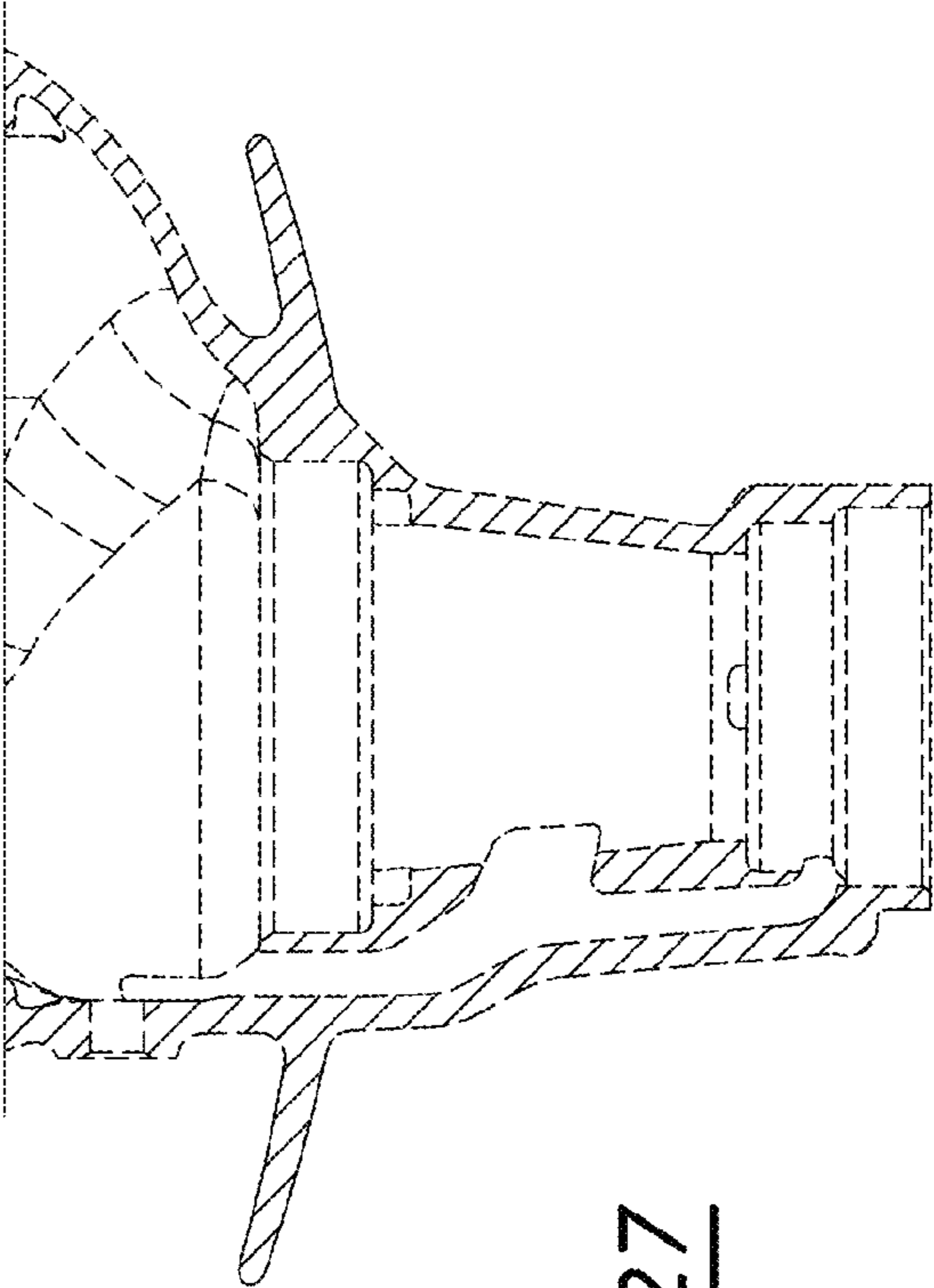

Fig-27

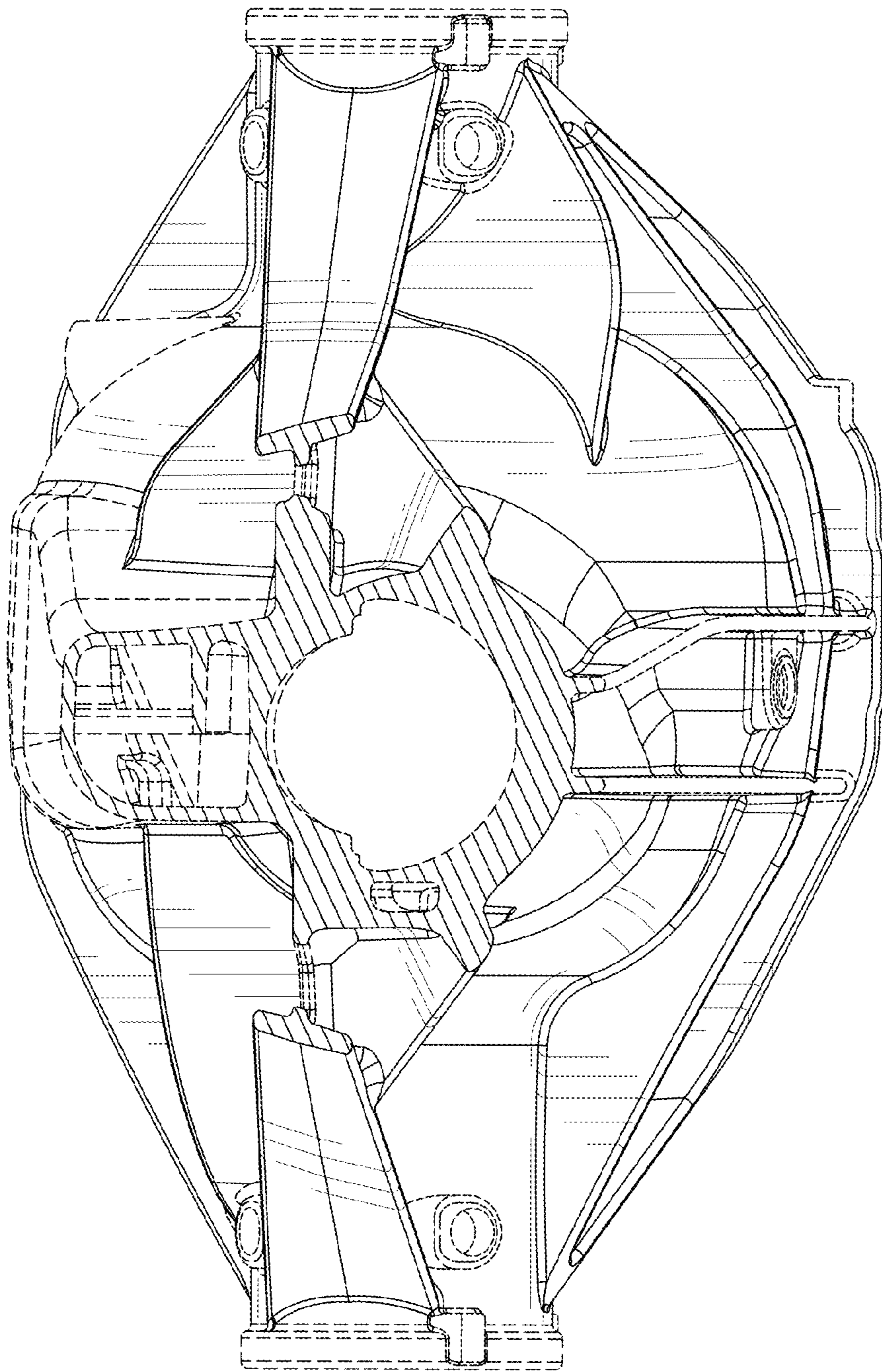

Fig-28