



US00D747668S

(12) **United States Design Patent**
Chen

(10) **Patent No.:** **US D747,668 S**
(45) **Date of Patent:** **** Jan. 19, 2016**

- (54) **ONE-WHEELED VEHICLE**
- (71) Applicant: **Shane Chen**, Camas, WA (US)
- (72) Inventor: **Shane Chen**, Camas, WA (US)
- (**) Term: **14 Years**
- (21) Appl. No.: **29/481,683**
- (22) Filed: **Feb. 10, 2014**
- (51) **LOC (10) Cl.** **12-11**
- (52) **U.S. Cl.**
USPC **D12/107**
- (58) **Field of Classification Search**
USPC D12/1, 107, 109, 110; 180/7.1, 11, 13,
180/20, 21, 65.1, 65.51, 205.1-205.7, 313;
280/205
CPC B62D 61/00; B62K 1/00; B62K 3/007;
B62K 3/17
See application file for complete search history.

D626,892	S	*	11/2010	Shin	D12/107
D673,081	S	*	12/2012	Chen	D12/107
D691,926	S	*	10/2013	Ungar	D12/107
8,613,453	B2	*	12/2013	Chen	280/11.24
8,807,250	B2	*	8/2014	Chen	180/21
2008/0143073	A1	*	6/2008	Ungar et al.	280/205
2009/0266629	A1	*	10/2009	Simeray et al.	180/65.51

* cited by examiner

Primary Examiner — Phillip S Hyder
Assistant Examiner — Darlington Ly

(57) **CLAIM**
The ornamental design for a one-wheeled vehicle, as shown and described.

DESCRIPTION

FIG. 1 is a perspective view of the one-wheeled vehicle; FIG. 2 is a front elevation view thereof, wherein the rear elevation view is a mirror image; FIG. 3 is a top plan view thereof; FIG. 4 is a side elevation view thereof, wherein the opposing side is a mirror image; and, FIG. 5 is a bottom plan view thereof. The broken lines enclosing elongated curved areas on the left and right sides of the vehicle (visible in FIGS. 1-4) are for the purpose of illustrating leg contact pads and form no part of the claimed design.

1 Claim, 2 Drawing Sheets

- (56) **References Cited**
U.S. PATENT DOCUMENTS
D217,175 S * 4/1970 Swanberg D12/107
4,861,053 A * 8/1989 Yeomans, Jr. 280/205
D505,363 S * 5/2005 Aube et al. D12/107
D535,714 S * 1/2007 Cheng et al. D21/763
D624,136 S * 9/2010 Chen D21/760
D624,137 S * 9/2010 Chen D21/760

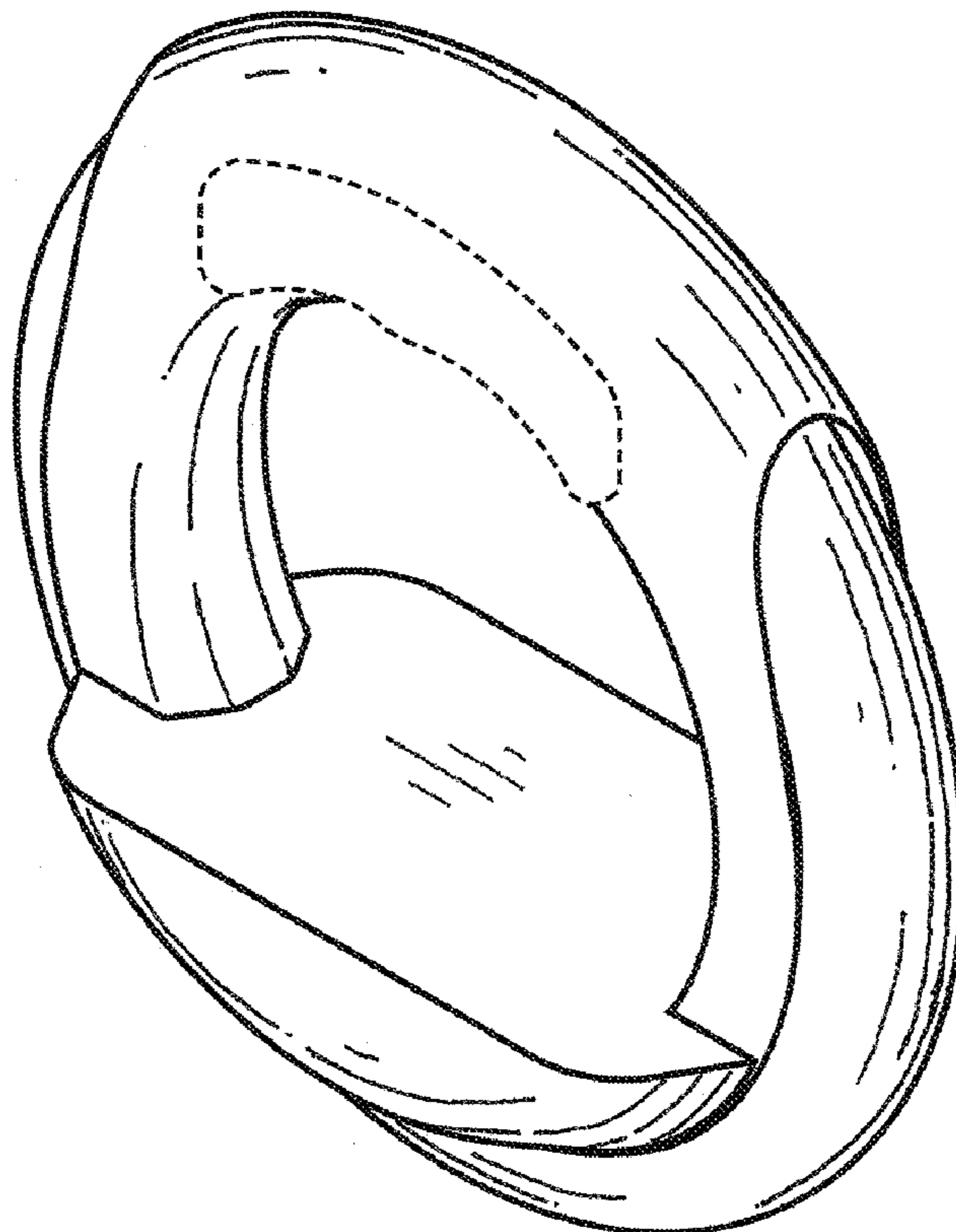

Fig. 1

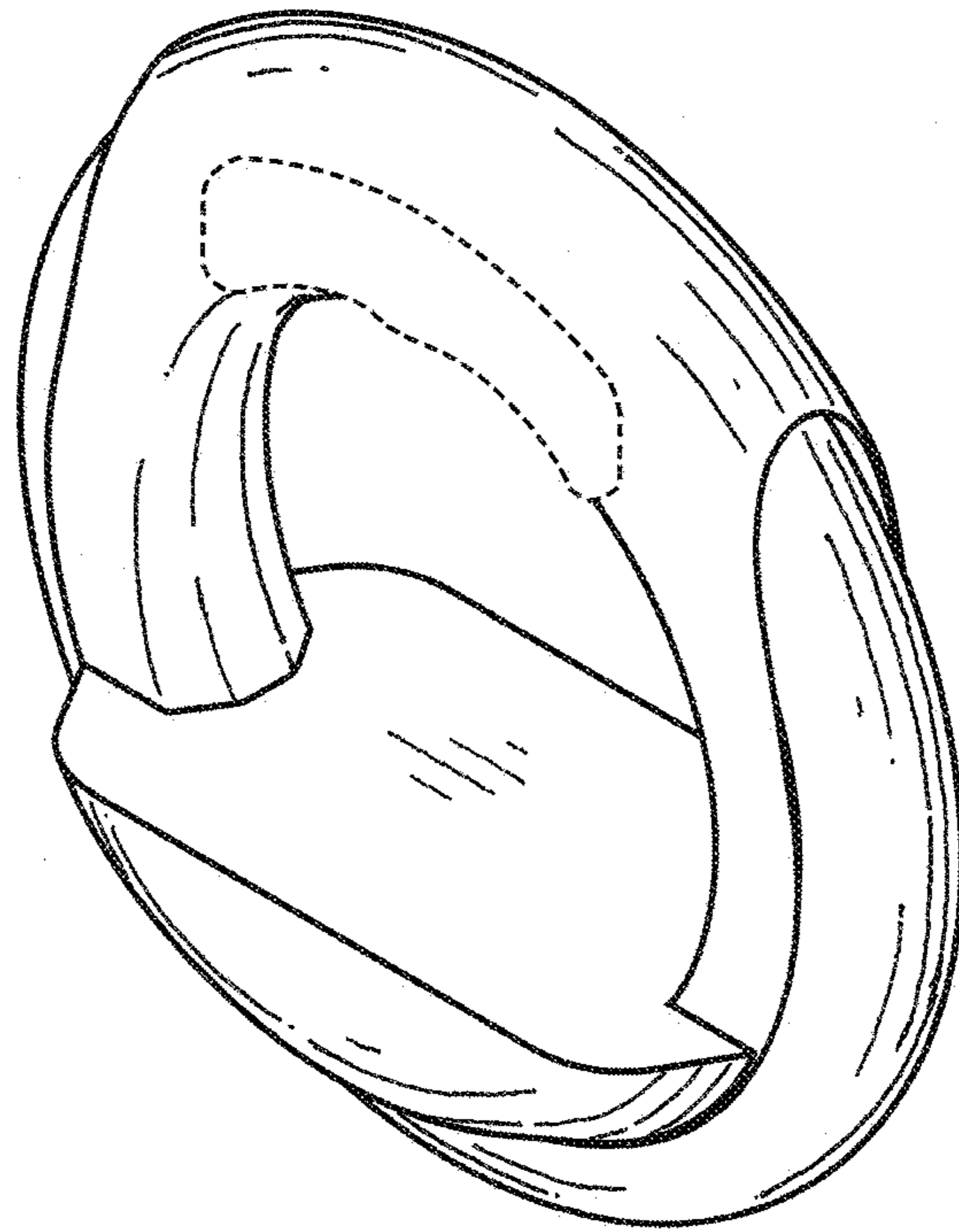

Fig. 2

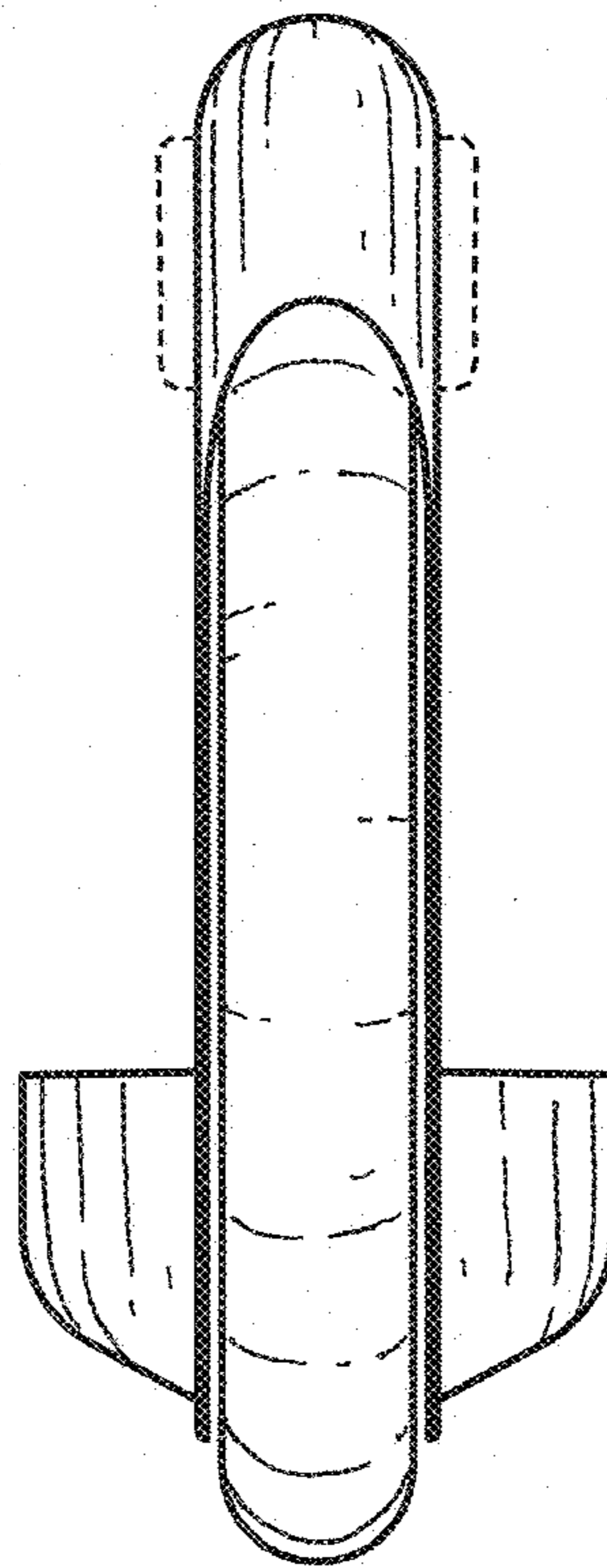

Fig. 3

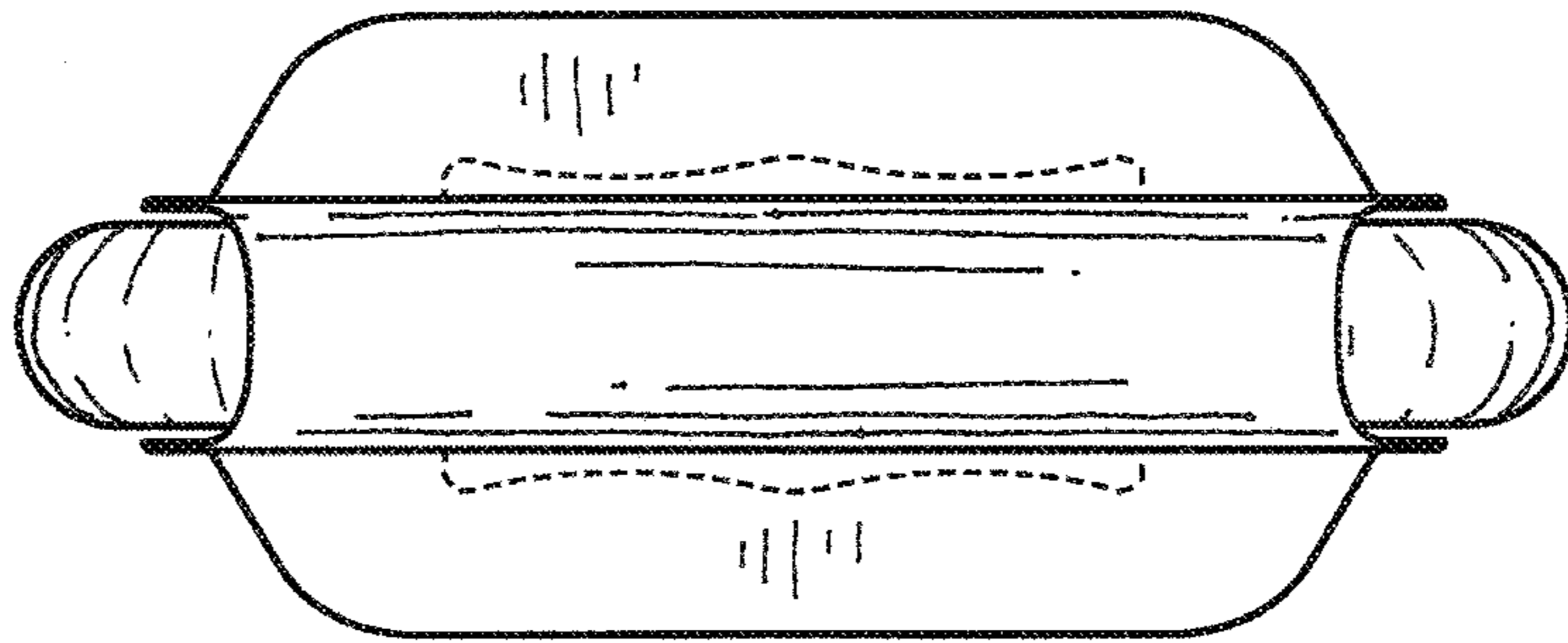

Fig. 4

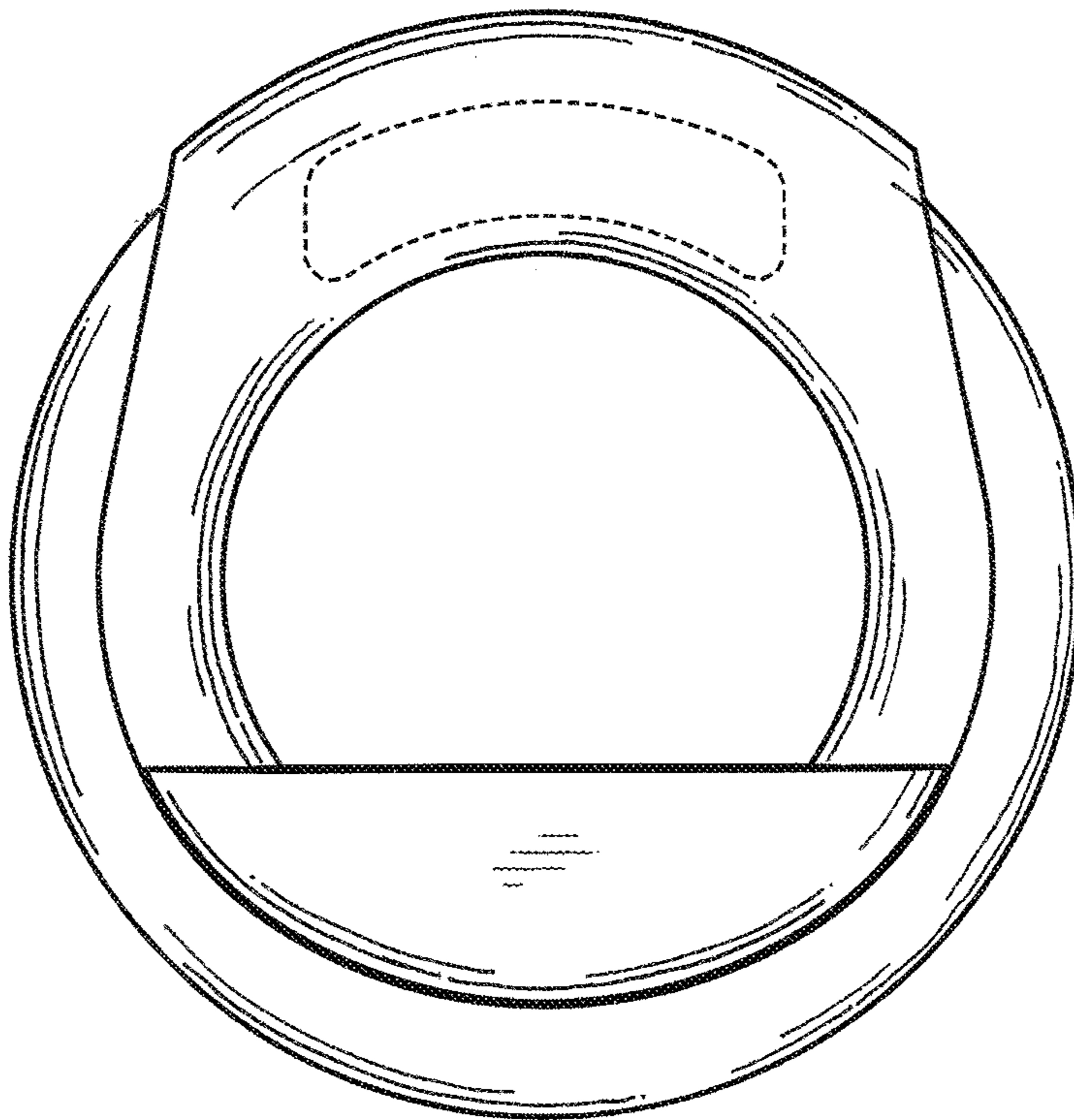

Fig. 5

