



US00D747649S

(12) **United States Design Patent**
Phillips

(10) **Patent No.:** **US D747,649 S**

(45) **Date of Patent:** **** *Jan. 19, 2016**

(54) **CAN END**

(71) Applicant: **B.E. Inventive, LLC**, Coral Springs, FL (US)

(72) Inventor: **Evan I. Phillips**, Coral Springs, FL (US)

(73) Assignee: **B.E. INVENTIVE, LLC**, Coral Springs, FL (US)

(*) Notice: This patent is subject to a terminal disclaimer.

(**) Term: **14 Years**

(21) Appl. No.: **29/479,373**

(22) Filed: **Jan. 15, 2014**

(51) **LOC (10) Cl.** **09-07**

(52) **U.S. Cl.**
USPC **D9/438**

(58) **Field of Classification Search**

USPC D7/392.1, 396.2, 541, 553.2, 605;
D9/434, 435, 438, 443, 447, 454, 518,
D9/538, 763, 767, 772; 53/306, 308, 452,
53/486, 492; 215/305; 220/220, 253,
220/254.4, 258.5, 265, 267-273, 276, 288,
220/377, 703, 711, 713, 730, 793;
222/153.07

See application file for complete search history.

(56) **References Cited**

U.S. PATENT DOCUMENTS

2,600,086 A 6/1952 Vastano
2,880,899 A 4/1959 Bramming

(Continued)

FOREIGN PATENT DOCUMENTS

EP 0305598 A1 3/1989
EP 0513401 A1 11/1992

(Continued)

OTHER PUBLICATIONS

U.S. Appl. No. 12/626,306, filed Nov. 25, 2009.

(Continued)

Primary Examiner — Robert M Spear

(74) *Attorney, Agent, or Firm* — Lando & Anastasi, LLP

(57) **CLAIM**

The ornamental design for a can end, as shown and described.

DESCRIPTION

FIG. 1 is a perspective view of a first embodiment of a can end;
FIG. 2 is a perspective view of the first embodiment shown in FIG. 1, rotated 90 degrees;
FIG. 3 is a side view of the embodiment shown in FIG. 1, with the opposite side being a mirror image thereof;
FIG. 4 is a side view of the embodiment shown in FIG. 1, rotated 90 degrees from the side view shown in FIG. 3 and with the opposite side being a mirror image thereof;
FIG. 5 is a top plan view of the embodiments shown in FIG. 1 and FIG. 2;
FIG. 6 is a bottom plan view of the embodiments shown in FIG. 1 and FIG. 2;
FIG. 7 is a perspective view of a second embodiment of a can end;
FIG. 8 is a perspective view of the second embodiment shown in FIG. 7, rotated 90 degrees;
FIG. 9 is a side view of the embodiment shown in FIG. 7, with the opposite side being a mirror image thereof;
FIG. 10 is a side view of the embodiment shown in FIG. 7, rotated 90 degrees from the side view shown in FIG. 9 and with the opposite side being a mirror image thereof;
FIG. 11 is a top plan view of the embodiments shown in FIG. 7 and FIG. 8;
FIG. 12 is a bottom plan view of the embodiments shown in FIG. 7 and FIG. 8;
FIG. 13 is a perspective view of a third embodiment of a can end;
FIG. 14 is a perspective view of the third embodiment shown in FIG. 13, rotated 90 degrees;
FIG. 15 is a side view of the embodiment shown in FIG. 13 and FIG. 14, with the opposite side being a mirror image thereof;
FIG. 16 is a side view of the embodiment shown in FIG. 13 and FIG. 14, rotated 90 degrees from the side view shown in FIG. 15 and with the opposite side being a mirror image thereof;
FIG. 17 is a top plan view of the embodiments shown in FIG. 13 and FIG. 14; and,
FIG. 18 is a bottom plan view of the embodiments shown in FIG. 13 and FIG. 14.
All broken lines shown in the drawings depict unclaimed environmental subject matter only and form no part of the claimed design.

1 Claim, 18 Drawing Sheets

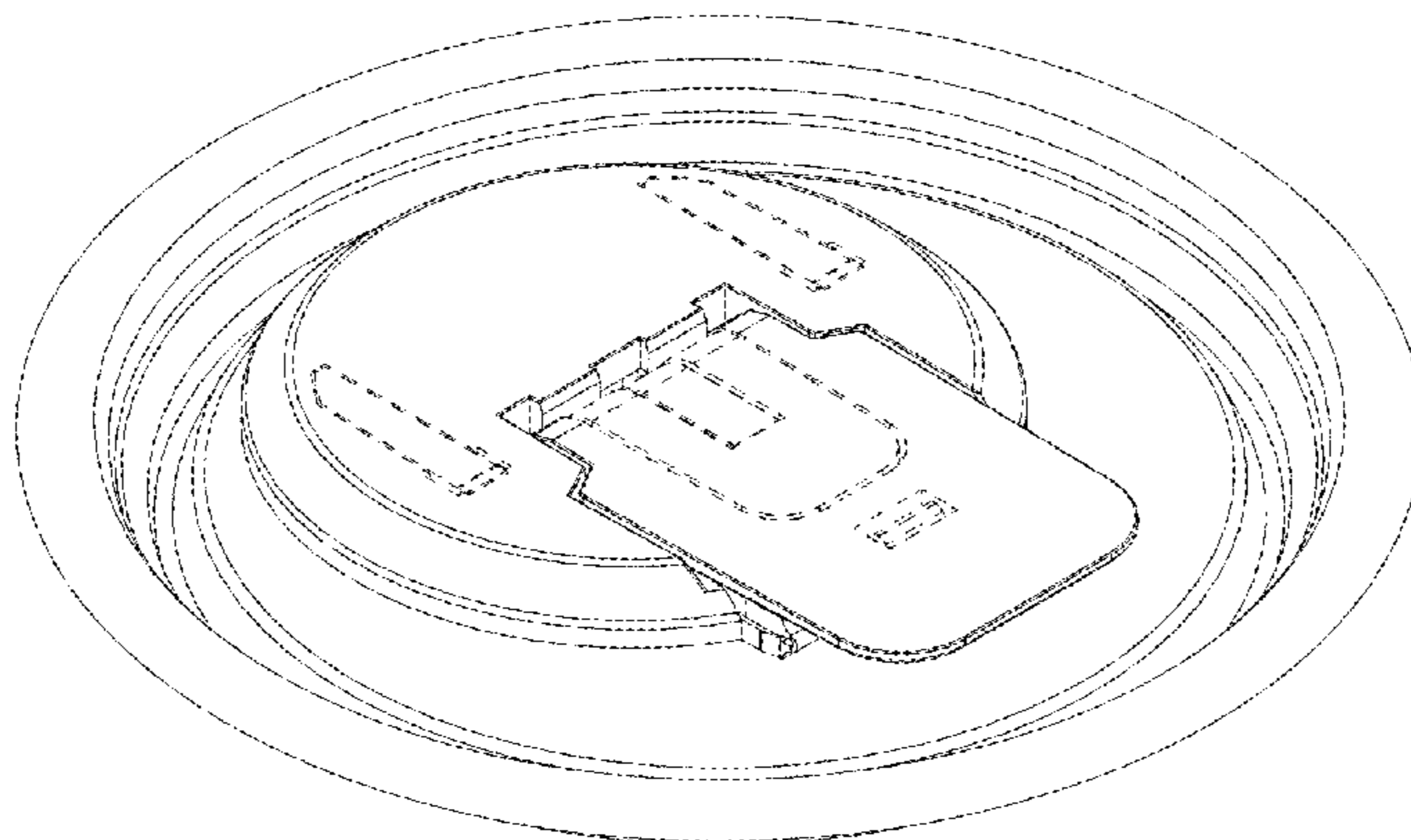

(56)

References Cited

U.S. PATENT DOCUMENTS

2,963,187 A	12/1960	Bramming	D354,438 S *	1/1995	Miller	D9/438
3,017,047 A	1/1962	Payson et al.	5,402,904 A	4/1995	Close	
3,086,675 A	4/1963	Clark, Jr.	5,439,103 A	8/1995	Howes	
3,158,279 A	11/1964	Callegari	5,451,271 A	9/1995	Yoshida et al.	
3,399,810 A	9/1968	Burne	5,462,189 A	10/1995	Pierce	
3,412,892 A	11/1968	Waksman et al.	5,467,888 A	11/1995	Brandstrom et al.	
3,578,198 A	5/1971	Blechman	D366,832 S	2/1996	Lo	
3,662,944 A	5/1972	Joosten, Sr.	5,547,275 A	8/1996	Lillelund et al.	
3,727,787 A	4/1973	Gregory	5,555,993 A	9/1996	Borkowski et al.	
3,967,752 A	7/1976	Cudzik	5,562,205 A	10/1996	Diaz	
3,967,753 A	7/1976	Cudzik	5,609,277 A	3/1997	McDonald	
3,979,025 A	9/1976	Friedrich et al.	D379,065 S	5/1997	Dotson	
3,982,656 A	9/1976	Kusmierski et al.	D379,148 S	5/1997	Robbins, III et al.	
4,057,167 A	11/1977	Lee	D379,434 S	5/1997	Robbins, III et al.	
4,127,212 A	11/1978	Waterbury	5,632,417 A	5/1997	Robbins, III et al.	
4,136,797 A	1/1979	Potts	D380,679 S	7/1997	Schreiber	
4,183,443 A	1/1980	DeParales et al.	5,671,875 A	9/1997	Robbins, III et al.	
4,262,815 A	4/1981	Klein	5,680,952 A	10/1997	Chasteen	
4,269,321 A	5/1981	Ichinose et al.	5,690,246 A	11/1997	Anderson et al.	
D261,364 S *	10/1981	Smyth	5,704,240 A	1/1998	Jordan	
4,309,921 A	1/1982	Miller	5,713,235 A	2/1998	Diekhoff	
4,319,692 A	3/1982	Gundlach	5,718,352 A	2/1998	Diekhoff et al.	
4,333,582 A	6/1982	Bloeck et al.	5,720,408 A	2/1998	Schmid et al.	
4,370,190 A	1/1983	Ichinose et al.	5,722,561 A	3/1998	Biondich et al.	
4,410,102 A	10/1983	Lutzker	5,755,198 A	5/1998	Grob et al.	
4,429,804 A	2/1984	Pease	5,755,354 A	5/1998	Lang	
4,431,111 A	2/1984	Prohaska	5,778,723 A	7/1998	Diekhoff	
4,449,042 A	5/1984	Hampson et al.	5,785,198 A	7/1998	Credle, Jr.	
4,465,203 A	8/1984	Lambert	5,785,199 A	7/1998	Woidtke	
D278,888 S	5/1985	Plumb	5,791,503 A	8/1998	Lyons	
4,546,905 A	10/1985	Nandagiri et al.	5,791,528 A	8/1998	Robbins, III et al.	
4,560,081 A	12/1985	Adams	5,797,522 A	8/1998	Evans et al.	
4,564,116 A	1/1986	Prohaska	5,813,561 A	9/1998	Chang et al.	
4,579,257 A	4/1986	Brandlein	5,816,427 A	10/1998	Beckertgis	
4,585,140 A	4/1986	Lambert et al.	5,816,428 A	10/1998	Plester	
4,600,111 A	7/1986	Brown	5,822,843 A	10/1998	Diekhoff et al.	
4,609,123 A	9/1986	Poncy	5,845,800 A	12/1998	Shaw et al.	
4,681,238 A	7/1987	Sanchez	5,850,944 A	12/1998	Robbins, III et al.	
4,700,856 A	10/1987	Campbell et al.	5,865,036 A	2/1999	Anthony	
4,717,037 A	1/1988	van der Meulen	5,894,965 A	4/1999	Robbins, III et al.	
4,720,022 A	1/1988	Gomes	D410,388 S	6/1999	Fisher et al.	
4,723,684 A	2/1988	Lambert et al.	5,911,331 A	6/1999	Boller	
4,746,032 A	5/1988	Huang	5,934,497 A	8/1999	Chang et al.	
4,749,100 A	6/1988	Eberhart	5,944,238 A	8/1999	Stark	
4,796,774 A	1/1989	Nabinger	5,946,930 A	9/1999	Anthony	
4,883,192 A	11/1989	Krugman	5,947,324 A	9/1999	Palinchak	
4,893,725 A	1/1990	Ball et al.	5,971,231 A	10/1999	Samz et al.	
4,899,902 A	2/1990	DeMars	5,984,127 A	11/1999	Fenton	
4,909,407 A	3/1990	Lambert et al.	5,993,935 A	11/1999	Rasmussen et al.	
4,911,323 A	3/1990	Arfert et al.	D417,583 S	12/1999	Demore	
4,917,258 A	4/1990	Boyd et al.	6,010,026 A	1/2000	Diekhoff et al.	
4,928,844 A	5/1990	LaBarge	6,010,028 A	1/2000	Jordan et al.	
4,930,654 A	6/1990	Thibeault et al.	6,015,062 A	1/2000	Bachmann et al.	
4,930,655 A	6/1990	Wells	6,041,982 A	3/2000	Cautereels et al.	
4,930,658 A	6/1990	McEldowney	6,079,588 A	6/2000	Khafizov	
4,932,555 A	6/1990	La Barge	6,082,944 A	7/2000	Bachmann et al.	
4,936,494 A	6/1990	Weidman	6,098,830 A	8/2000	Jamieson	
4,957,216 A	9/1990	LaBarge	6,102,242 A	8/2000	Jansen	
4,967,622 A	11/1990	Phillips	6,106,757 A	8/2000	Ohlsson et al.	
4,982,862 A	1/1991	La Barge	6,155,452 A	12/2000	Laurent	
4,991,732 A	2/1991	La Barge et al.	6,158,608 A	12/2000	Schlattl	
5,005,717 A	4/1991	Oilar	6,164,503 A	12/2000	Forsyth et al.	
5,035,343 A	7/1991	Morton	D436,538 S	1/2001	Lang	
5,062,542 A	11/1991	Morton	6,170,283 B1	1/2001	Anthony	
5,071,019 A	12/1991	Sizemore	6,193,094 B1	2/2001	Diamond et al.	
5,121,851 A	6/1992	Lyon et al.	6,206,222 B1	3/2001	Cudzik	
5,139,163 A	8/1992	Diaz	6,206,223 B1	3/2001	Wicker	
5,143,248 A	9/1992	Sawatsky	6,247,608 B1	6/2001	Chang et al.	
5,148,937 A	9/1992	Huard	6,250,507 B1	6/2001	Ekkert	
5,176,278 A	1/1993	Quarberg	6,250,517 B1	6/2001	Samz et al.	
5,186,348 A	2/1993	Steiner	D446,722 S	8/2001	Morrow	
5,199,597 A	4/1993	Gladish	D448,296 S	9/2001	Bried et al.	
5,273,176 A	12/1993	Diaz	6,286,703 B1	9/2001	Munro	
D345,673 S	4/1994	Dark	D448,668 S	10/2001	Baerenwald et al.	
5,299,604 A	4/1994	Pierce	D448,669 S	10/2001	Carducci et al.	
			6,308,870 B2	10/2001	Samz et al.	
			D450,584 S	11/2001	Schmit et al.	
			D450,586 S	11/2001	Kick	
			6,311,865 B1	11/2001	Laurent	

(56)

References Cited

U.S. PATENT DOCUMENTS

6,338,418 B1 1/2002 Derose
 6,341,720 B1 1/2002 Schmit et al.
 D453,892 S 2/2002 Lindsay et al.
 6,347,720 B1 2/2002 Schley
 6,354,458 B1 3/2002 Policappelli
 RE37,634 E 4/2002 Hickman et al.
 D456,713 S 5/2002 Bried et al.
 6,409,033 B1 6/2002 Wilhite et al.
 D462,613 S 9/2002 Bried et al.
 6,443,323 B1 9/2002 DeRose
 6,450,359 B1 9/2002 Chang et al.
 D464,567 S 10/2002 Baerenwald et al.
 D464,886 S 10/2002 Bried et al.
 6,460,718 B1 10/2002 Vogel
 D465,732 S 11/2002 Kick
 6,478,179 B1 11/2002 Alexander
 D466,408 S 12/2002 Baerenwald et al.
 D467,801 S 12/2002 Baerenwald et al.
 6,488,187 B2 12/2002 Sheffler et al.
 6,510,971 B1 1/2003 Martin
 D474,402 S 5/2003 Baerenwald
 6,575,323 B1 6/2003 Martin et al.
 6,575,684 B2 6/2003 Heinicke et al.
 6,626,314 B1 9/2003 McHenry et al.
 6,691,901 B2 2/2004 Parve et al.
 6,722,517 B1 4/2004 Steeber et al.
 6,732,873 B2 5/2004 Bried et al.
 6,742,666 B1 6/2004 Bried et al.
 6,783,020 B2 8/2004 Featherston et al.
 D498,419 S 11/2004 Martin
 6,830,721 B2 12/2004 Martin
 6,837,392 B2 1/2005 Laurent
 D502,398 S * 3/2005 Leonzo et al. D9/503
 6,889,861 B2 5/2005 Arcati et al.
 D507,934 S 8/2005 Featherston et al.
 D509,426 S 9/2005 Samz et al.
 6,968,724 B2 11/2005 Hubball
 D513,452 S 1/2006 Parve
 D513,585 S 1/2006 Biesecker et al.
 7,007,830 B2 3/2006 Parve et al.
 7,014,060 B2 3/2006 Richardson
 D522,362 S 6/2006 Liebe
 7,059,490 B2 6/2006 Son
 7,089,825 B2 8/2006 Klosterman
 D527,627 S 9/2006 Liebe
 D529,800 S 10/2006 Liebe
 D530,610 S 10/2006 Samz et al.
 7,121,438 B2 10/2006 Hoepner et al.
 7,128,227 B2 10/2006 Skillin et al.
 7,152,753 B2 12/2006 Huffman et al.
 7,152,766 B1 12/2006 Walsh et al.
 7,175,042 B2 2/2007 Durdon
 7,191,911 B2 3/2007 O'Neill
 7,246,716 B2 7/2007 Durdon
 7,275,653 B2 10/2007 Tedford, Jr.
 7,513,380 B2 4/2009 Canedo
 D600,118 S * 9/2009 Brehelin D9/438
 D646,971 S * 10/2011 Chmela D9/438
 8,857,644 B2 * 10/2014 Phillips 220/247
 2001/0035417 A1 11/2001 Kantor et al.
 2002/0027139 A1 3/2002 O'Neill
 2003/0029891 A1 2/2003 Alexander
 2003/0089713 A1 5/2003 Belt et al.
 2003/0089714 A1 5/2003 Dart et al.
 2003/0116524 A1 6/2003 Robinson et al.
 2003/0178433 A1 9/2003 Adams
 2003/0230575 A1 12/2003 Laurent
 2004/0060935 A1 4/2004 Perra
 2005/0006334 A1 1/2005 Luker
 2005/0092748 A1 5/2005 Durdon

2005/0092749 A1 5/2005 Durdon
 2005/0092755 A1 5/2005 Brown et al.
 2005/0098561 A1 5/2005 Schwoebel
 2005/0127075 A1 6/2005 Smith et al.
 2005/0139597 A1 6/2005 O'Neill
 2005/0150889 A1 7/2005 Perra
 2006/0000832 A1 1/2006 Smith et al.
 2006/0081633 A1 4/2006 Schmidtner et al.
 2006/0096983 A1 5/2006 Patterson
 2006/0180585 A1 8/2006 Cunningham et al.
 2006/0201944 A1 9/2006 Shibasaka et al.
 2006/0201945 A1 9/2006 Tedford
 2006/0237471 A1 10/2006 Aafjes
 2006/0261068 A1 11/2006 Schmidtner et al.
 2007/0012698 A1 1/2007 Durdon et al.
 2007/0029322 A1 2/2007 Durdon et al.
 2007/0131691 A1 6/2007 Evans
 2007/0145055 A1 6/2007 Gardiner
 2007/0215625 A1 9/2007 Schmidtner et al.
 2007/0257037 A1 11/2007 Scarborough
 2007/0262079 A1 11/2007 Paris et al.
 2008/0029512 A1 2/2008 Smith et al.
 2008/0053997 A1 3/2008 Perra
 2008/0245806 A1 10/2008 Strube
 2008/0314904 A1 12/2008 Perra
 2009/0173737 A1 7/2009 Ramsey et al.
 2010/0133275 A1* 6/2010 Phillips 220/270
 2012/0152949 A1 6/2012 Bratsch

FOREIGN PATENT DOCUMENTS

EP 0865993 A1 9/1998
 EP 1097087 A1 5/2001
 EP 01247752 A1 10/2002
 EP 01746042 A1 1/2007
 FR 2828478 A1 2/2003
 GB 02258208 A 2/1993
 GB 2317882 A 4/1998
 GB 2355644 A 5/2001
 JP 09095351 A 4/1997
 JP 10264931 A 10/1998
 NL 1021536 C1 3/2004
 NL 1024270 C2 3/2005
 WO 9009930 A1 9/1990
 WO 9407755 A1 4/1994
 WO 9747525 A1 12/1997
 WO 9805570 A1 2/1998
 WO 9967150 A1 12/1999
 WO 0002785 A1 1/2000
 WO 0039001 A1 7/2000
 WO 0131266 A1 5/2001
 WO 0214180 A1 2/2002
 WO 02081322 A1 10/2002
 WO 03042058 A2 5/2003
 WO 03047994 A2 6/2003
 WO 2004106187 A1 12/2004
 WO 2005023666 A1 3/2005
 WO 2005044676 A2 5/2005
 WO 2005056400 A1 6/2005
 WO 2005068312 A1 7/2005
 WO 2005068313 A1 7/2005
 WO 2005092728 A1 10/2005
 WO 2006009450 A1 1/2006
 WO 2006039044 A2 4/2006
 WO 2007047590 A2 4/2007
 WO 2009062004 A1 5/2009
 WO 2011124552 A1 10/2011
 WO 2012150301 A1 11/2012

OTHER PUBLICATIONS

U.S. Appl. No. 29/479,372, filed Jan. 15, 2014.

* cited by examiner

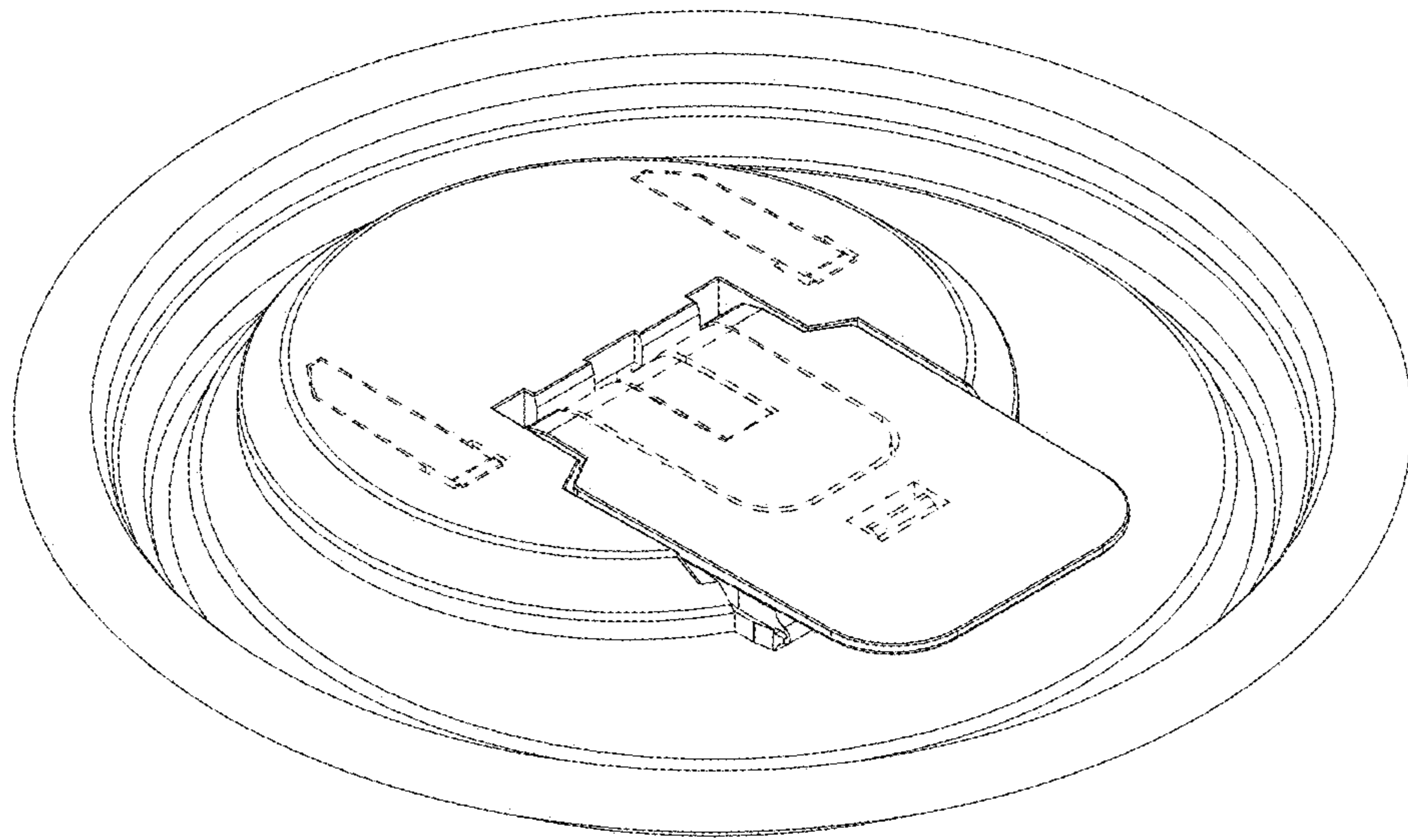

FIG. 1

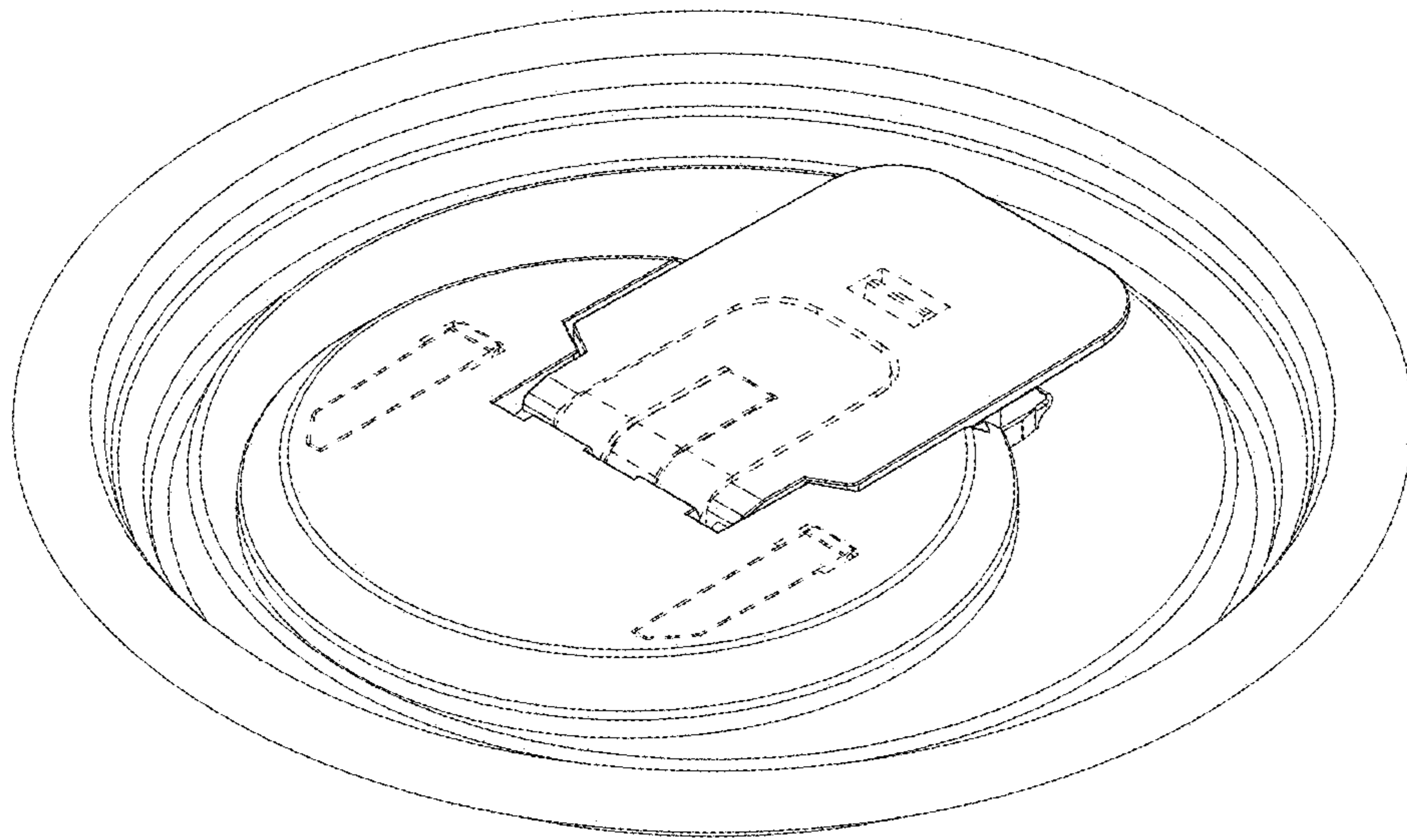

FIG. 2

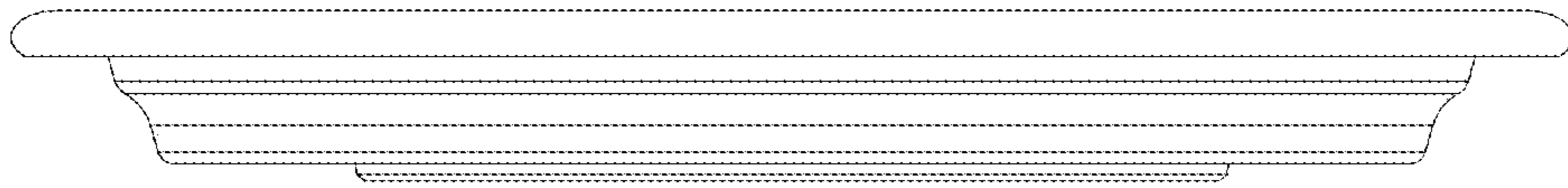

FIG. 3

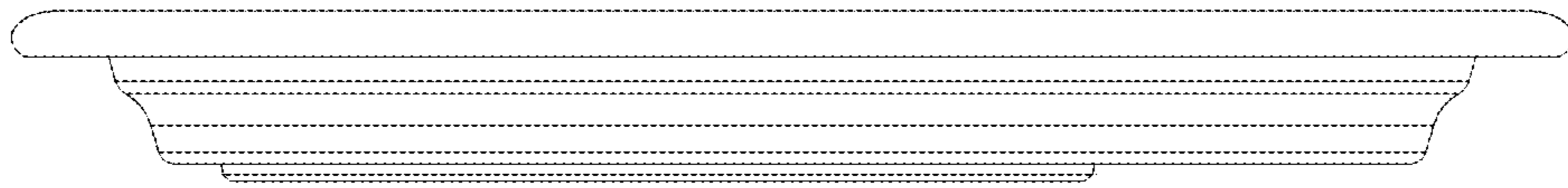

FIG. 4

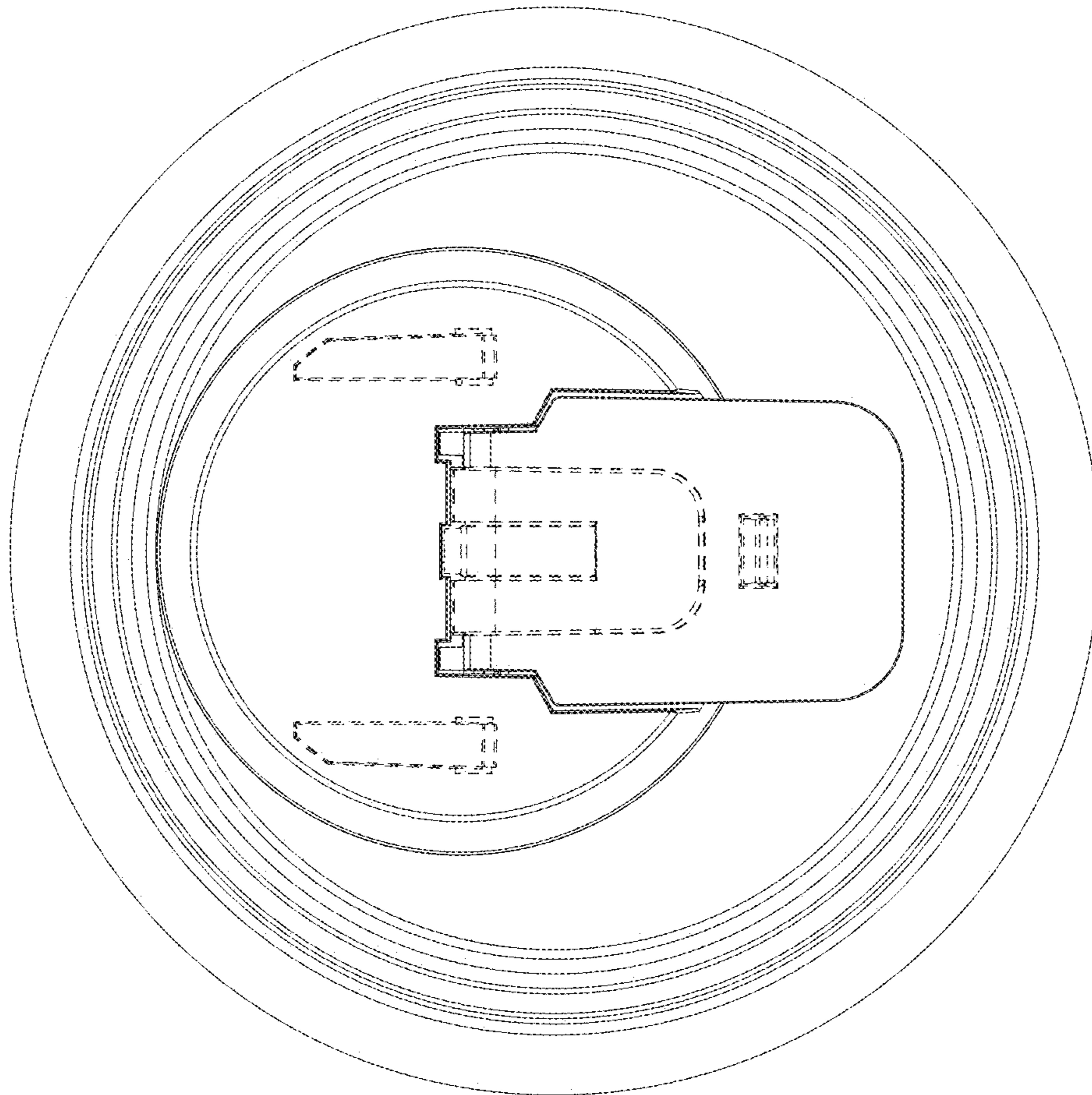

FIG. 5

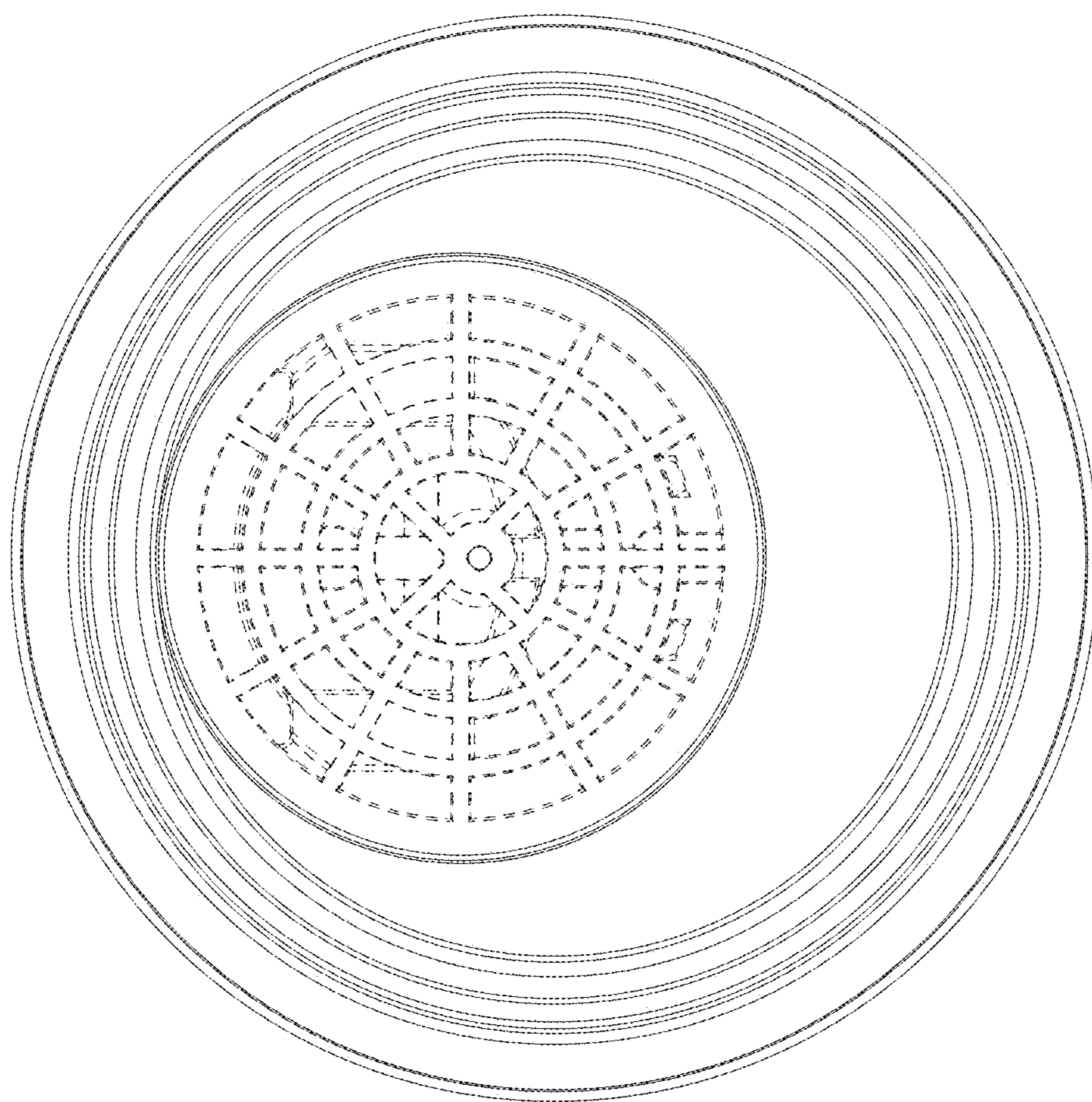

FIG. 6

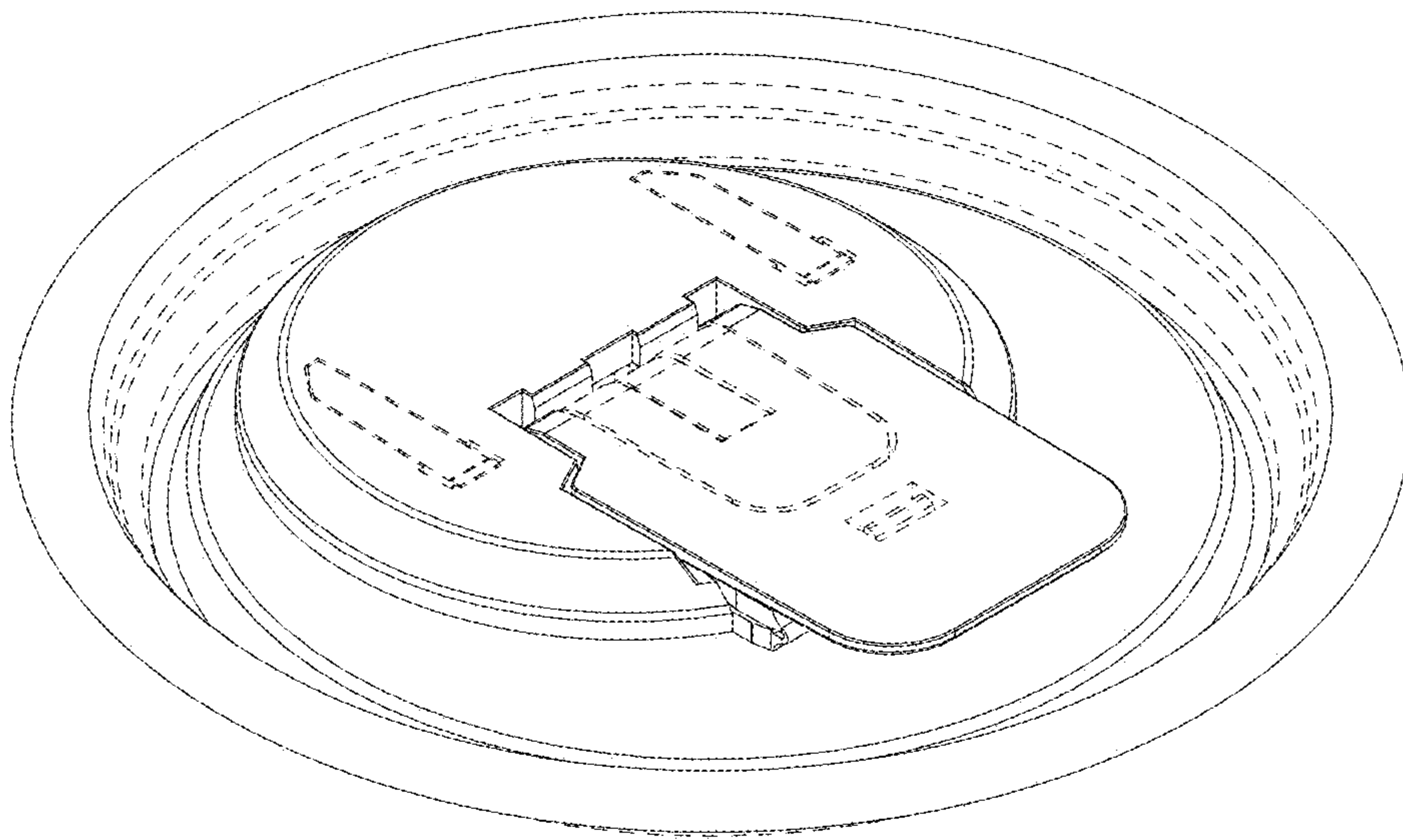

FIG. 7

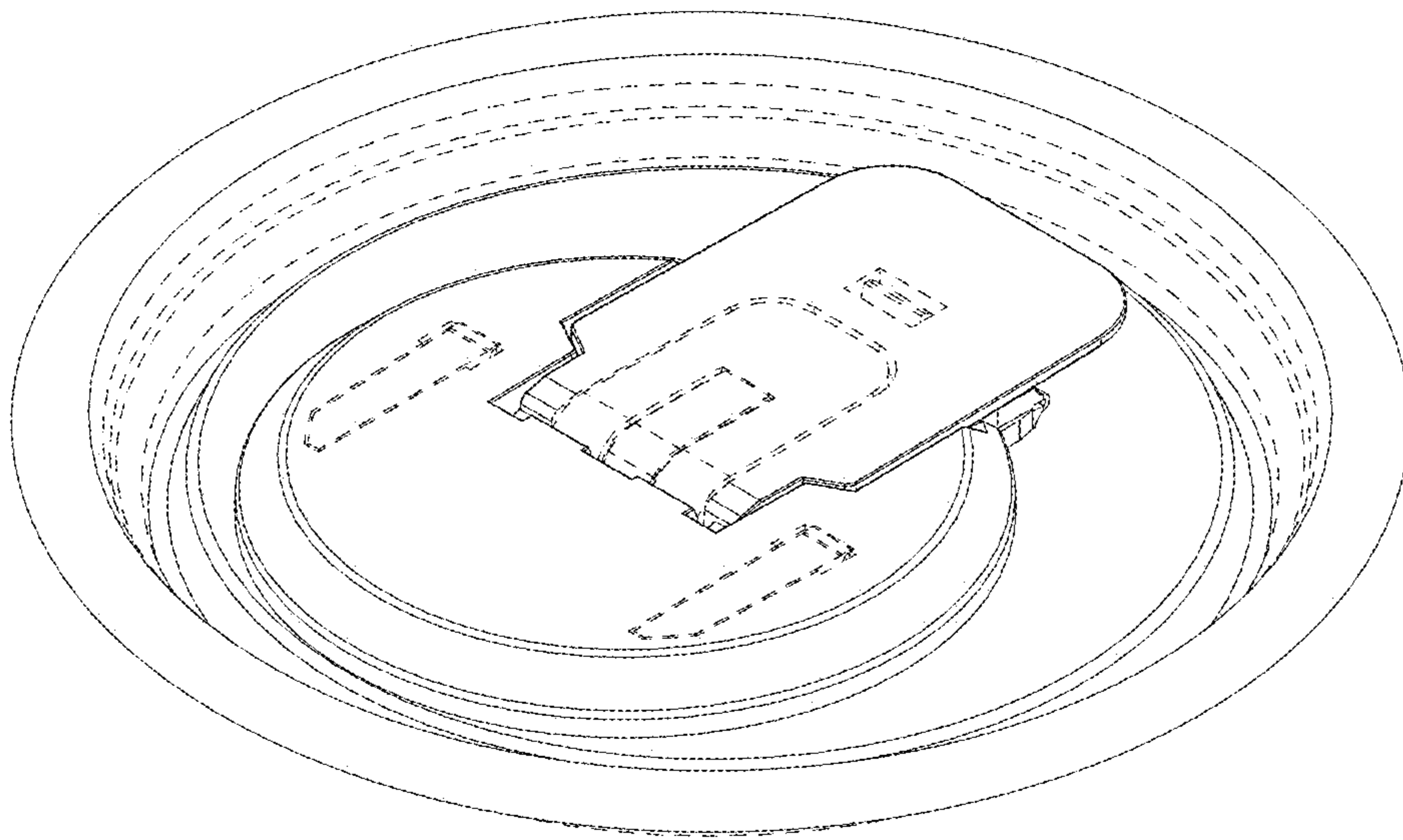

FIG. 8

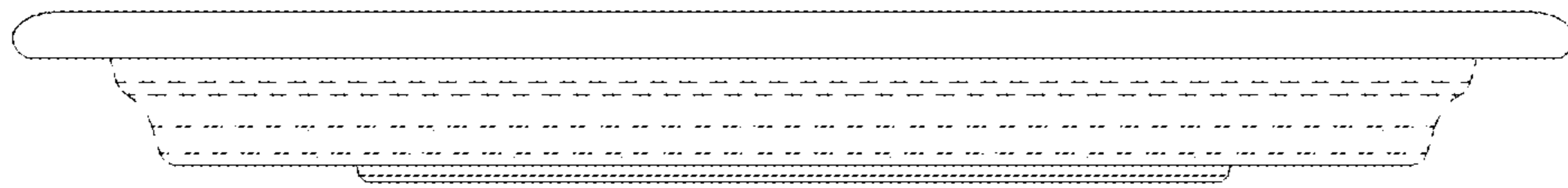

FIG. 9

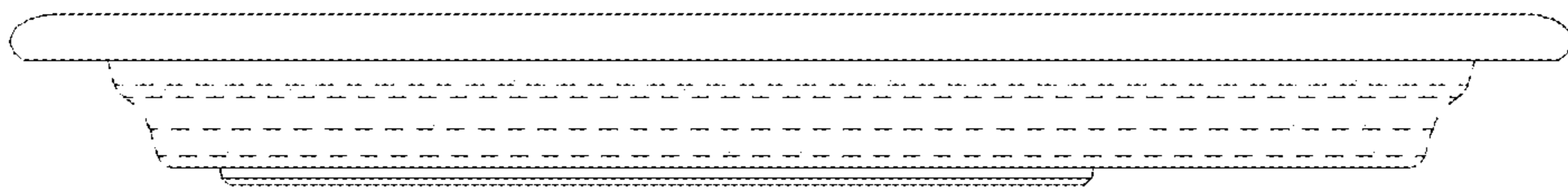

FIG. 10

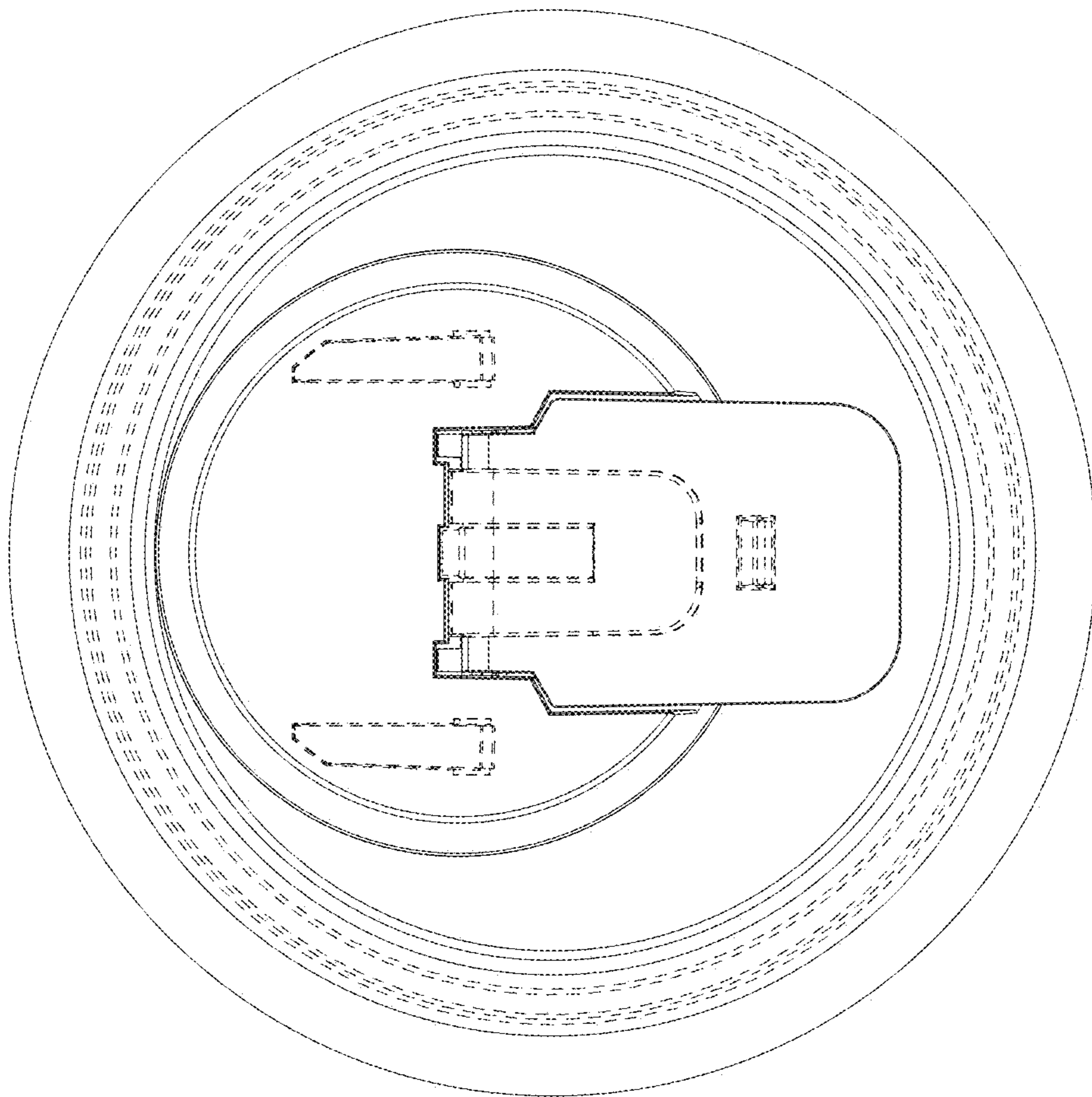

FIG. 11

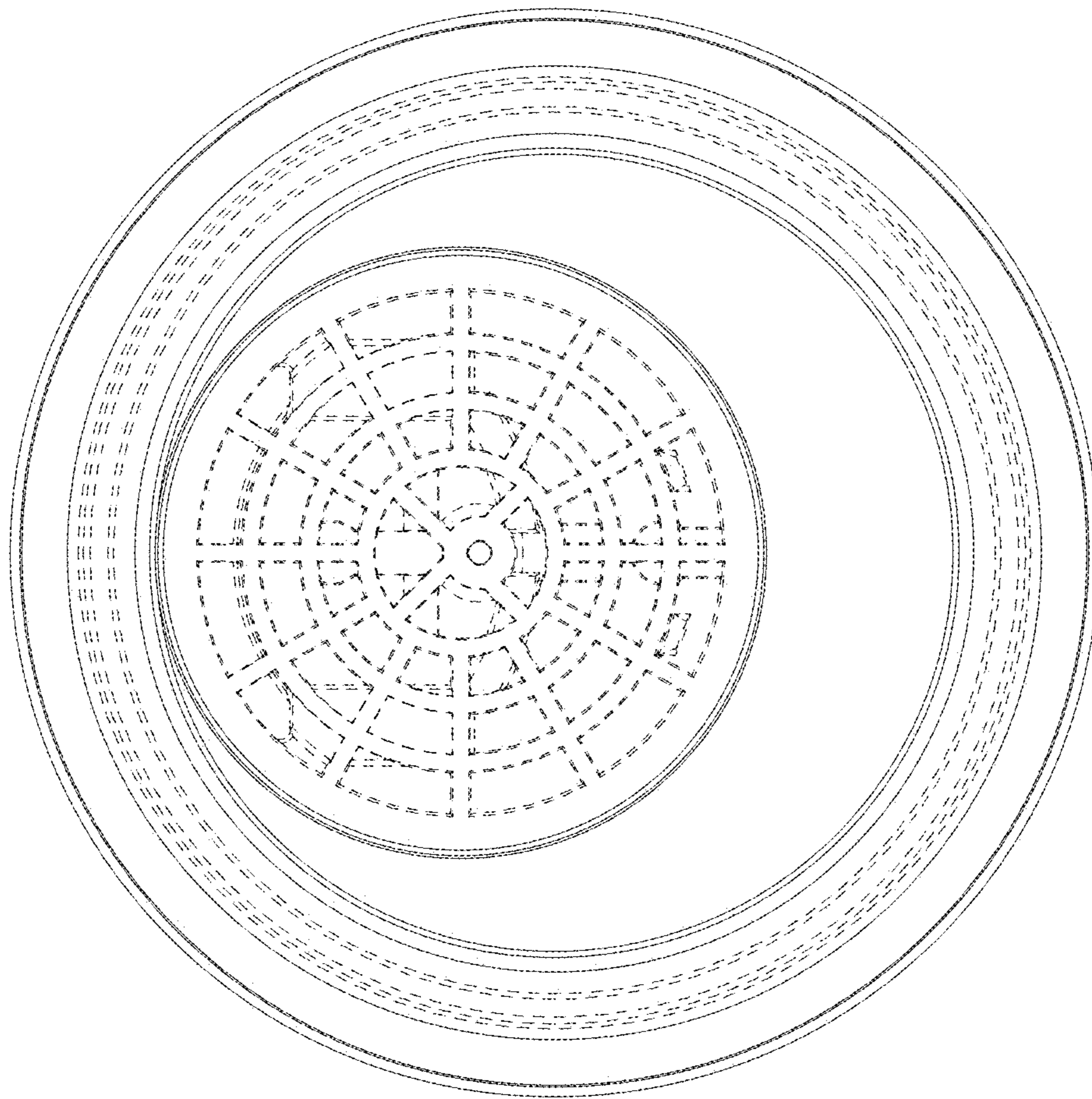

FIG. 12

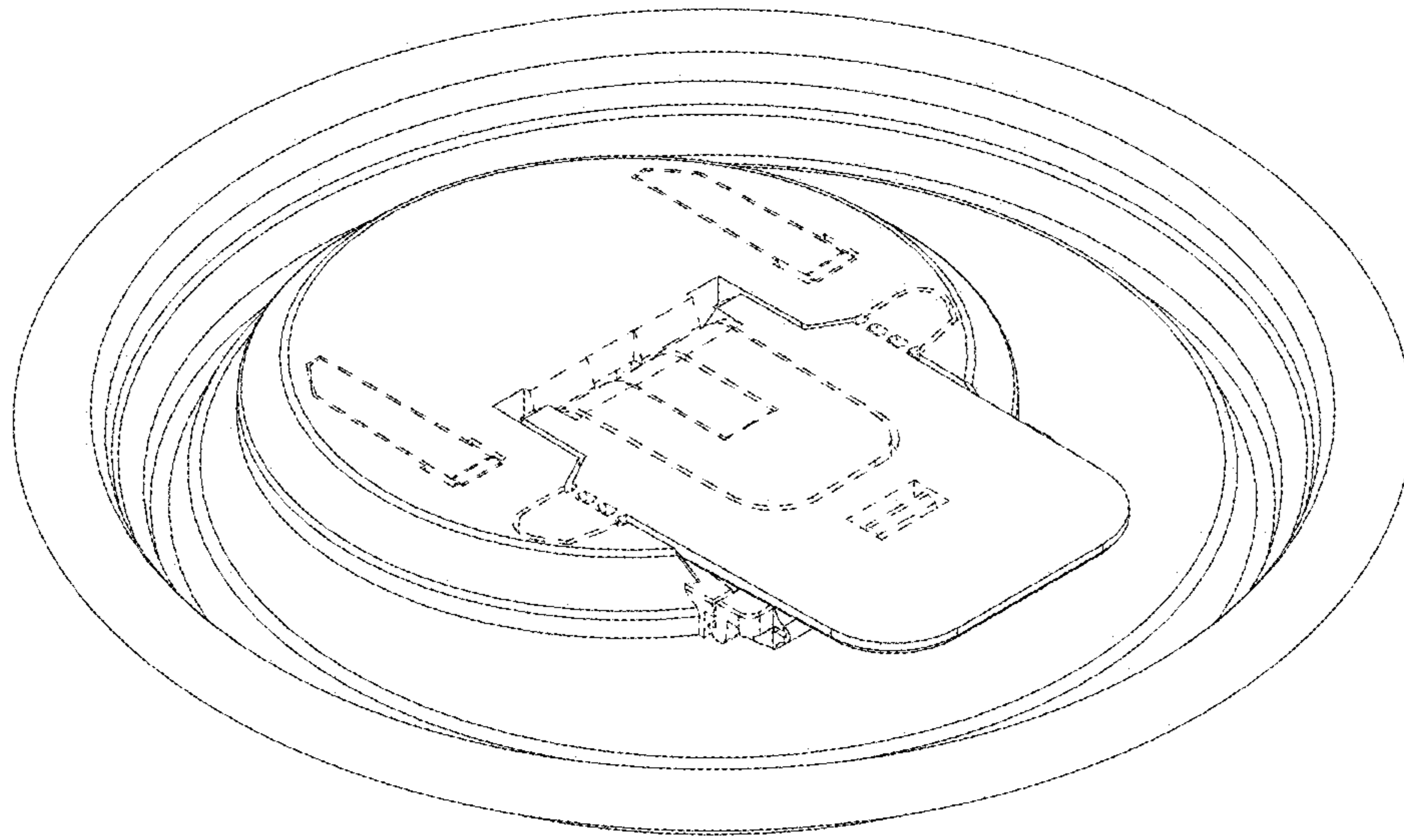

FIG. 13

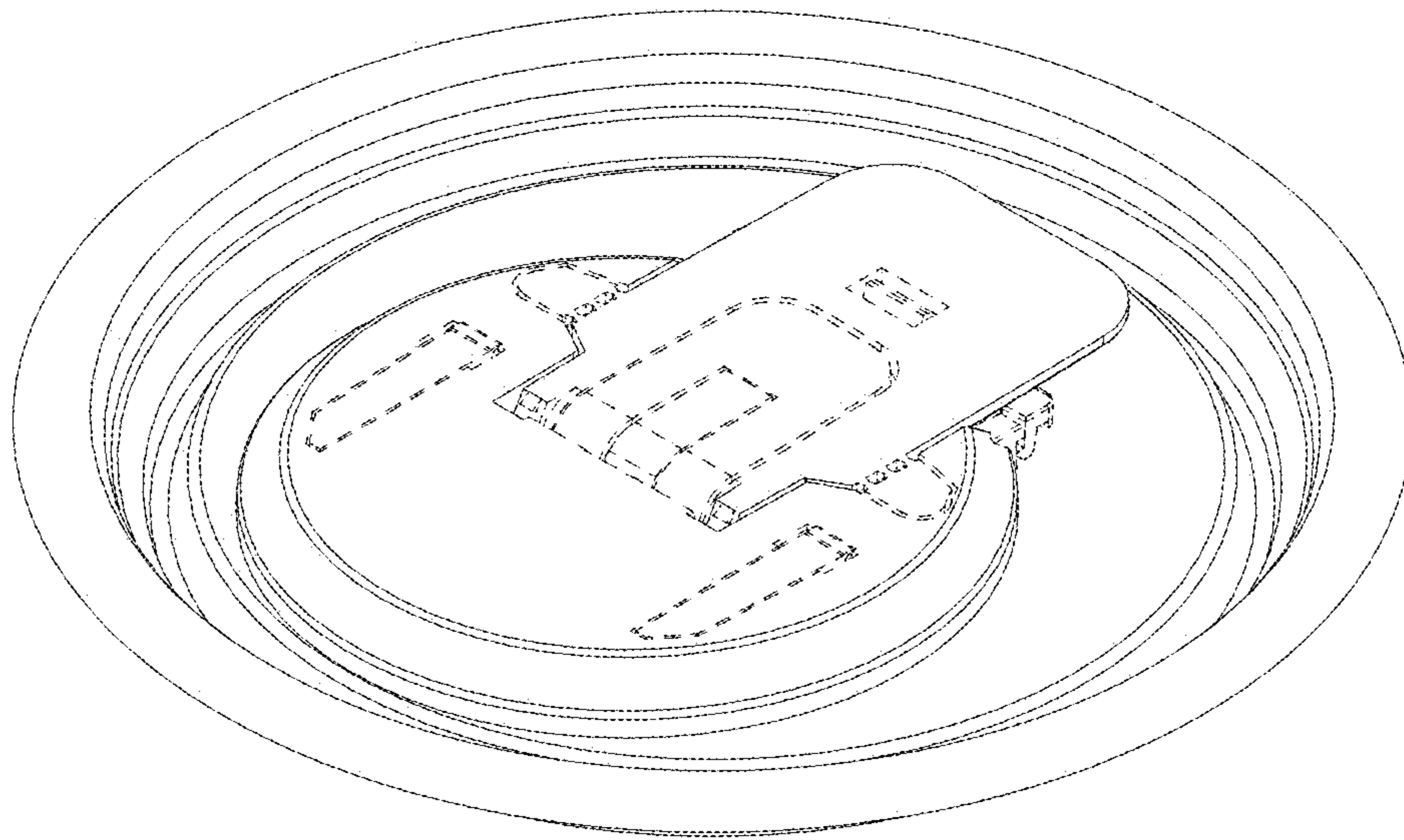

FIG. 14

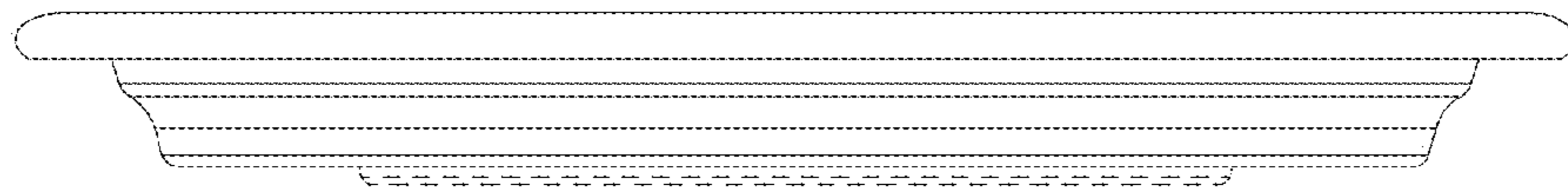

FIG. 15

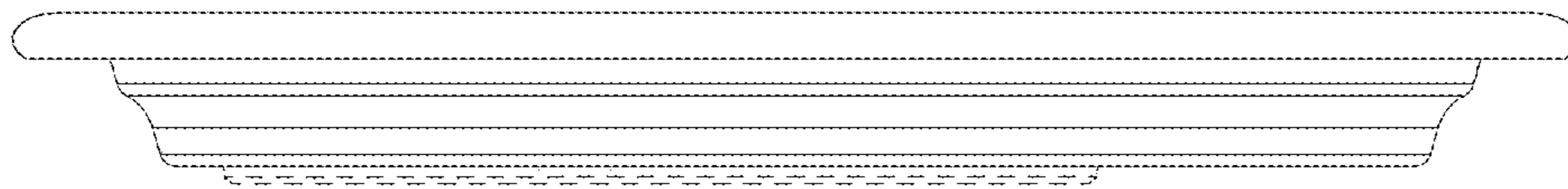

FIG. 16

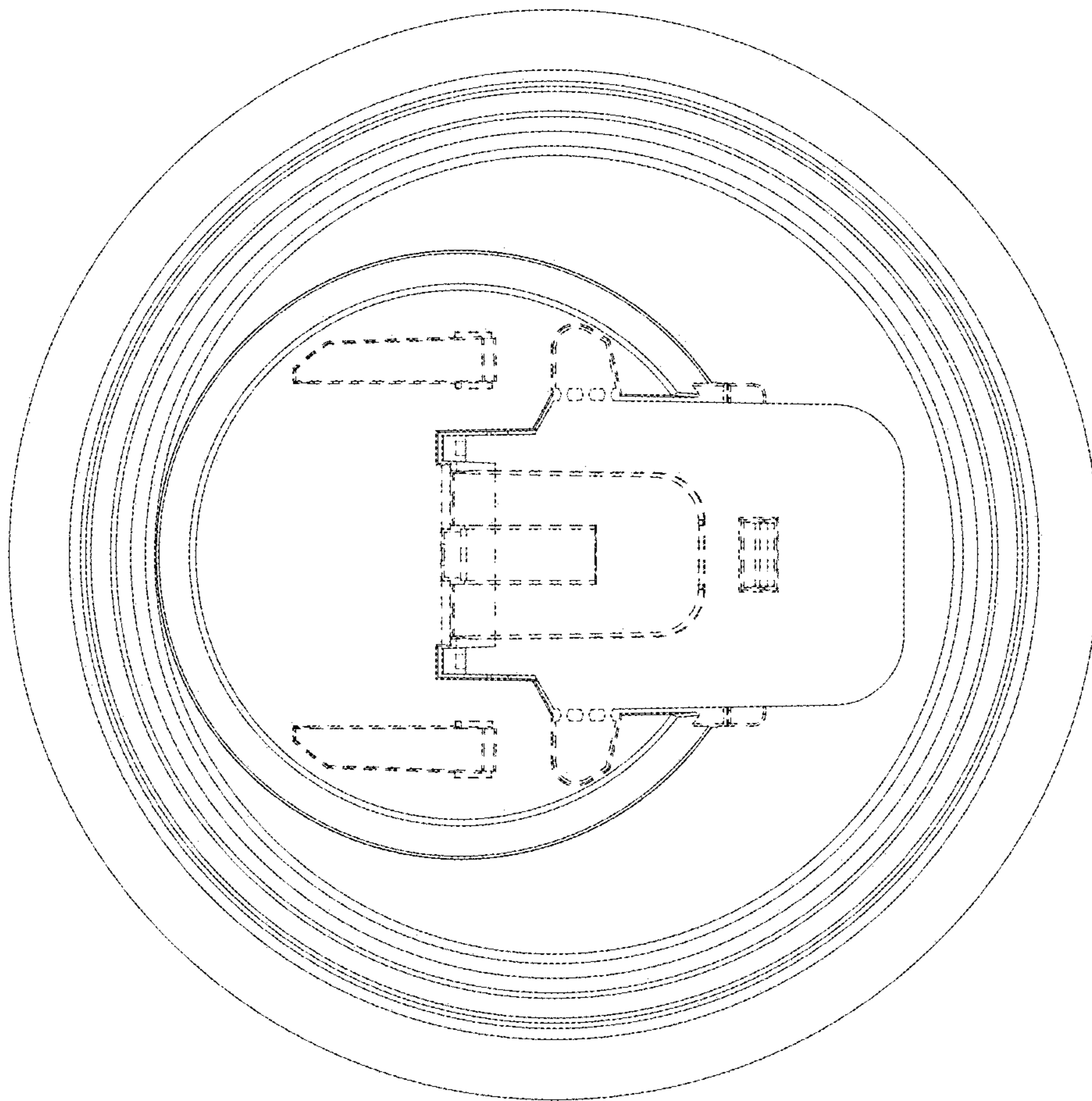

FIG. 17

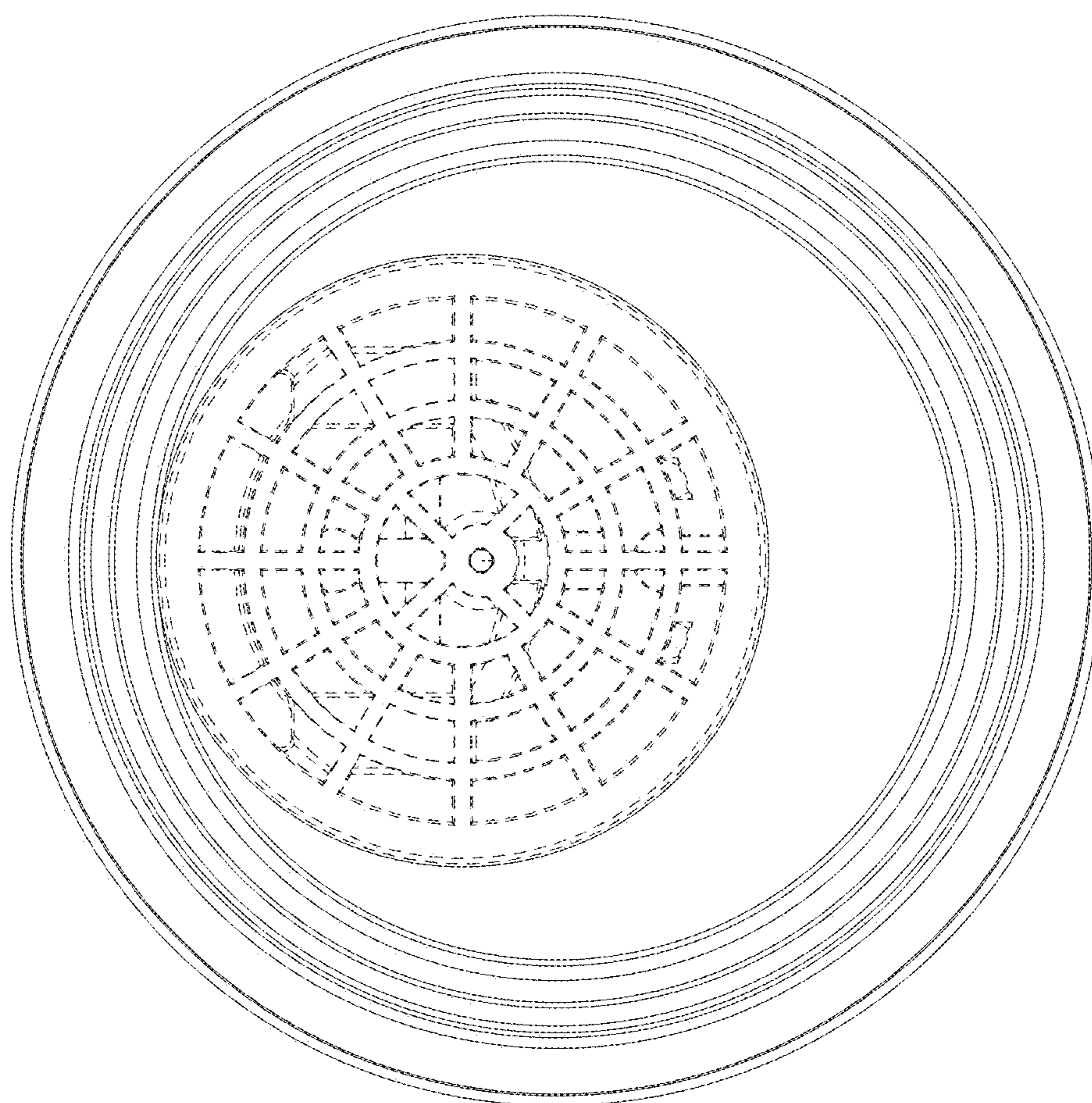

FIG. 18