



US00D746188S

(12) **United States Design Patent**
Nakagawa et al.

(10) **Patent No.:** **US D746,188 S**

(45) **Date of Patent:** **** Dec. 29, 2015**

(54) **REAR BUMPER FOR AUTOMOBILE**

(71) Applicant: **Nissan Motor Co., Ltd.**, Yokohama,
Kanagawa (JP)

(72) Inventors: **Shinichi Nakagawa**, Kanagawa (JP);
Yoshihiro Okada, Kanagawa (JP)

(73) Assignee: **Nissan Motor Co., Ltd.**, Yokohama (JP)

(**) Term: **14 Years**

(21) Appl. No.: **29/502,823**

(22) Filed: **Sep. 19, 2014**

(30) **Foreign Application Priority Data**

Mar. 19, 2014 (JP) 2014-005800

(51) **LOC (10) Cl.** **12-16**

(52) **U.S. Cl.**
USPC **D12/169**

(58) **Field of Classification Search**
USPC D12/169, 216, 90-92, 86, 171, 196,
D12/163; 293/102, 113, 115, 117, 120;
296/180.1, 180.2

CPC . B60R 19/52; B60R 2019/25; B62D 25/0845
See application file for complete search history.

(56) **References Cited**

U.S. PATENT DOCUMENTS

D598,824 S * 8/2009 Bauer et al. D12/169
D610,504 S * 2/2010 Bucher et al. D12/169
D630,976 S * 1/2011 Clottu D12/169
D644,575 S * 9/2011 Messale D12/169
D659,605 S * 5/2012 Varga D12/169
D671,049 S * 11/2012 Davidson et al. D12/169
D690,631 S * 10/2013 Kazama D12/169
D698,290 S * 1/2014 Mori et al. D12/169
D698,711 S 2/2014 Endo et al.
D698,712 S 2/2014 Sato et al.

D699,167 S 2/2014 Sato et al.
D703,592 S * 4/2014 Kwon et al. D12/169
D713,304 S * 9/2014 Tsuchida et al. D12/169
D714,196 S * 9/2014 Mays et al. D12/169
D715,708 S * 10/2014 Mays et al. D12/169
D718,678 S * 12/2014 Ishizuka et al. D12/169

FOREIGN PATENT DOCUMENTS

JP D1441551 S 5/2012
JP D1444803 S 6/2012
JP D1445040 S 7/2012
JP D1451939 S 10/2012
JP D1454373 S 11/2012
JP D1458082 S 12/2012
JP D1451046 S 1/2013
JP D1474813 S 7/2013
JP D1481526 S 10/2013

(Continued)

Primary Examiner — Melody N Brown

(74) *Attorney, Agent, or Firm* — Global IP Counselors, LLP

(57) **CLAIM**

The ornamental design for a rear bumper for an automobile,
as shown and described.

DESCRIPTION

FIG. 1 is a front elevational view of a rear bumper for auto-
mobile showing our new design;
FIG. 2 is a top plan view thereof;
FIG. 3 is a bottom plan view thereof;
FIG. 4 is a right side elevational view thereof;
FIG. 5 is a left side elevational thereof;
FIG. 6 is a top, front and right side perspective view thereof;
and,
FIG. 7 is a bottom, front and left side perspective view
thereof.
The rear view of the rear bumper forms no part of the claimed
design.

1 Claim, 7 Drawing Sheets

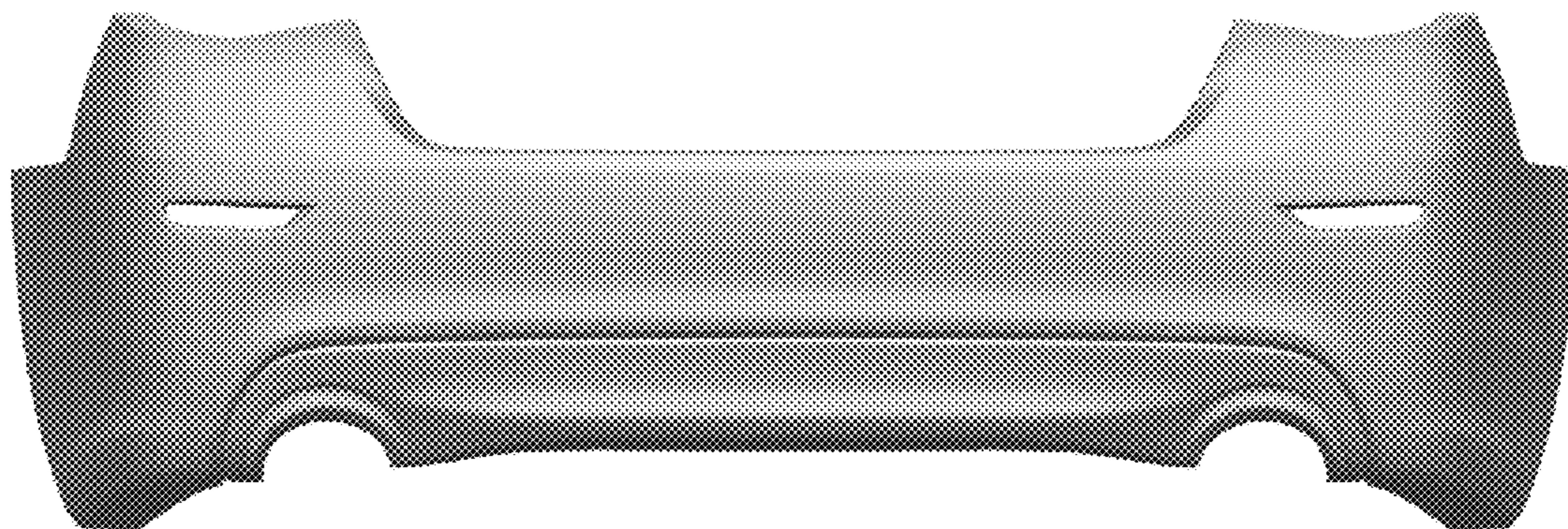

(56)

References Cited

FOREIGN PATENT DOCUMENTS

JP D1486085 S 12/2013
JP D1486325 S 12/2013
JP D1486870 S 12/2013
JP D1489383 S 2/2014

JP D1472543 S 6/2014
JP D1446730 S 7/2014
JP D1511275 S 11/2014
JP D1513119 S 12/2014
JP D1489460 S 2/2015
JP D1501249 S 6/2015
JP D1530845 S 8/2015

* cited by examiner

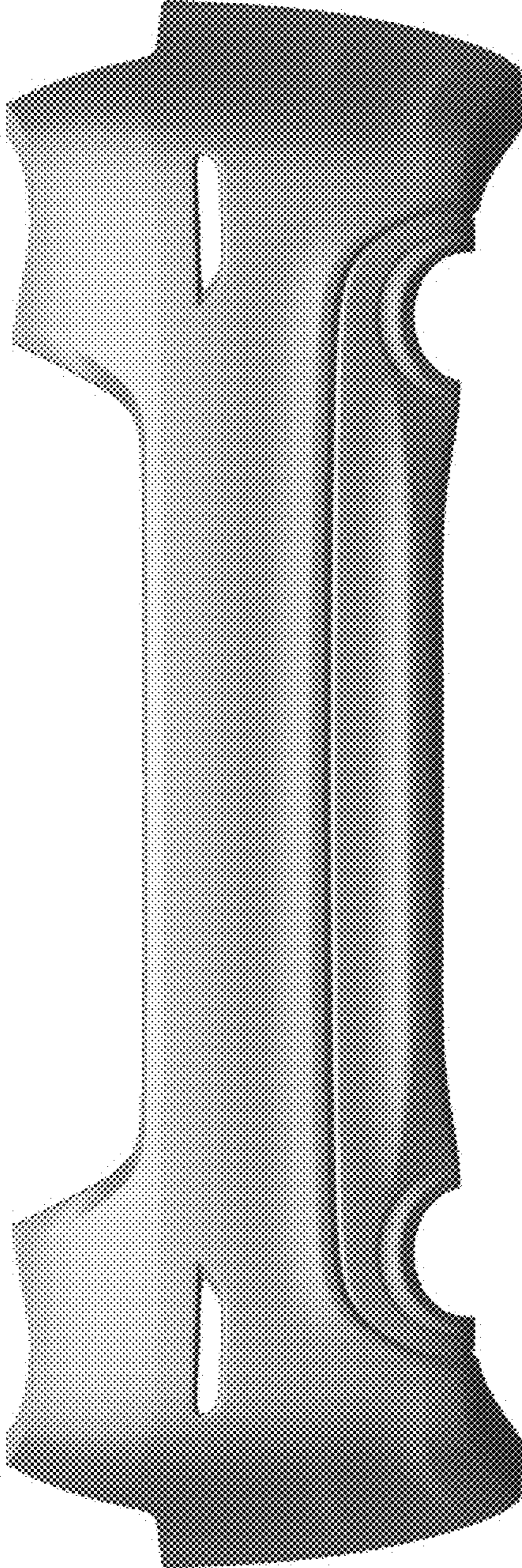

FIG. 1



FIG. 2

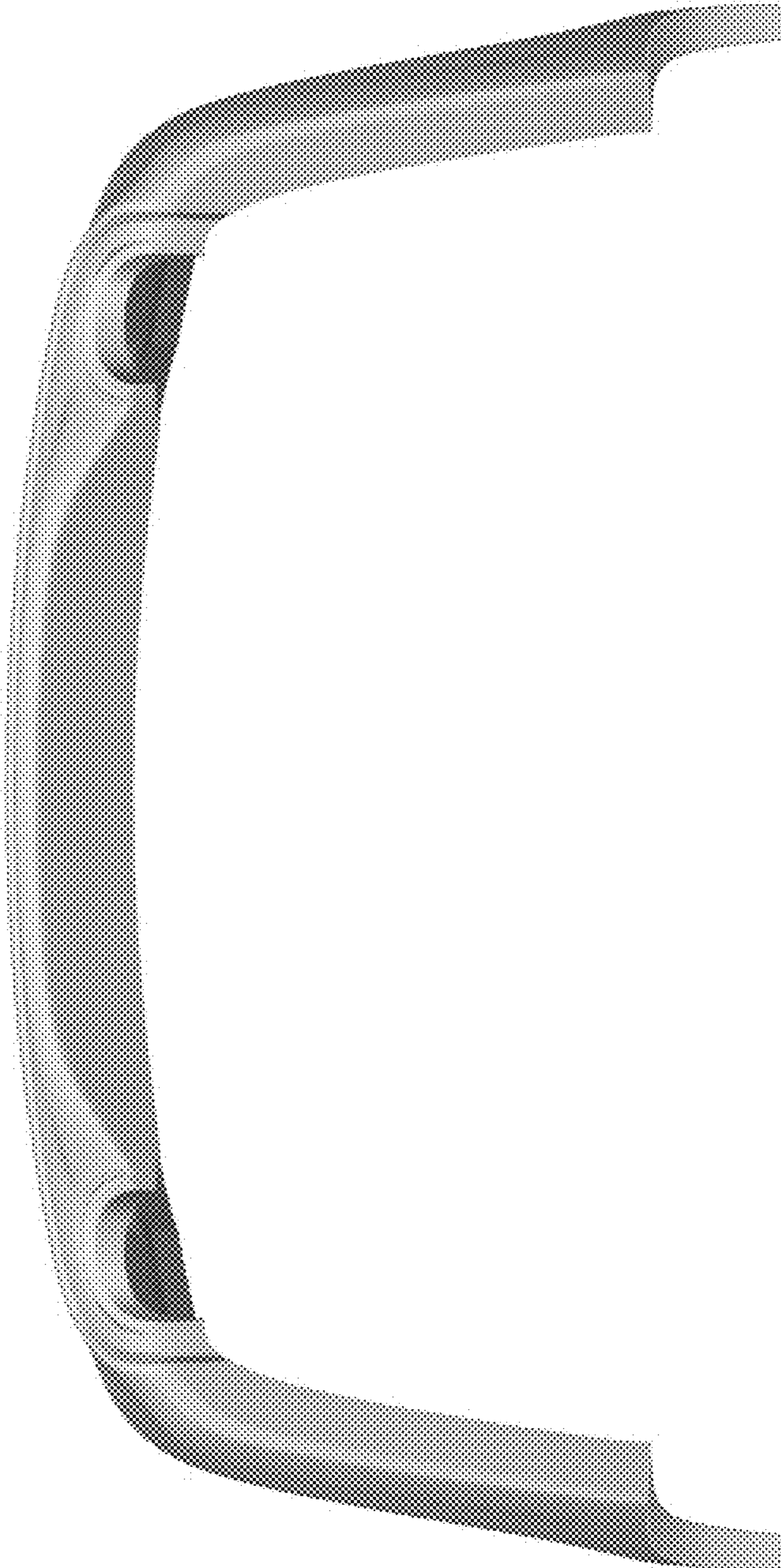

FIG. 3

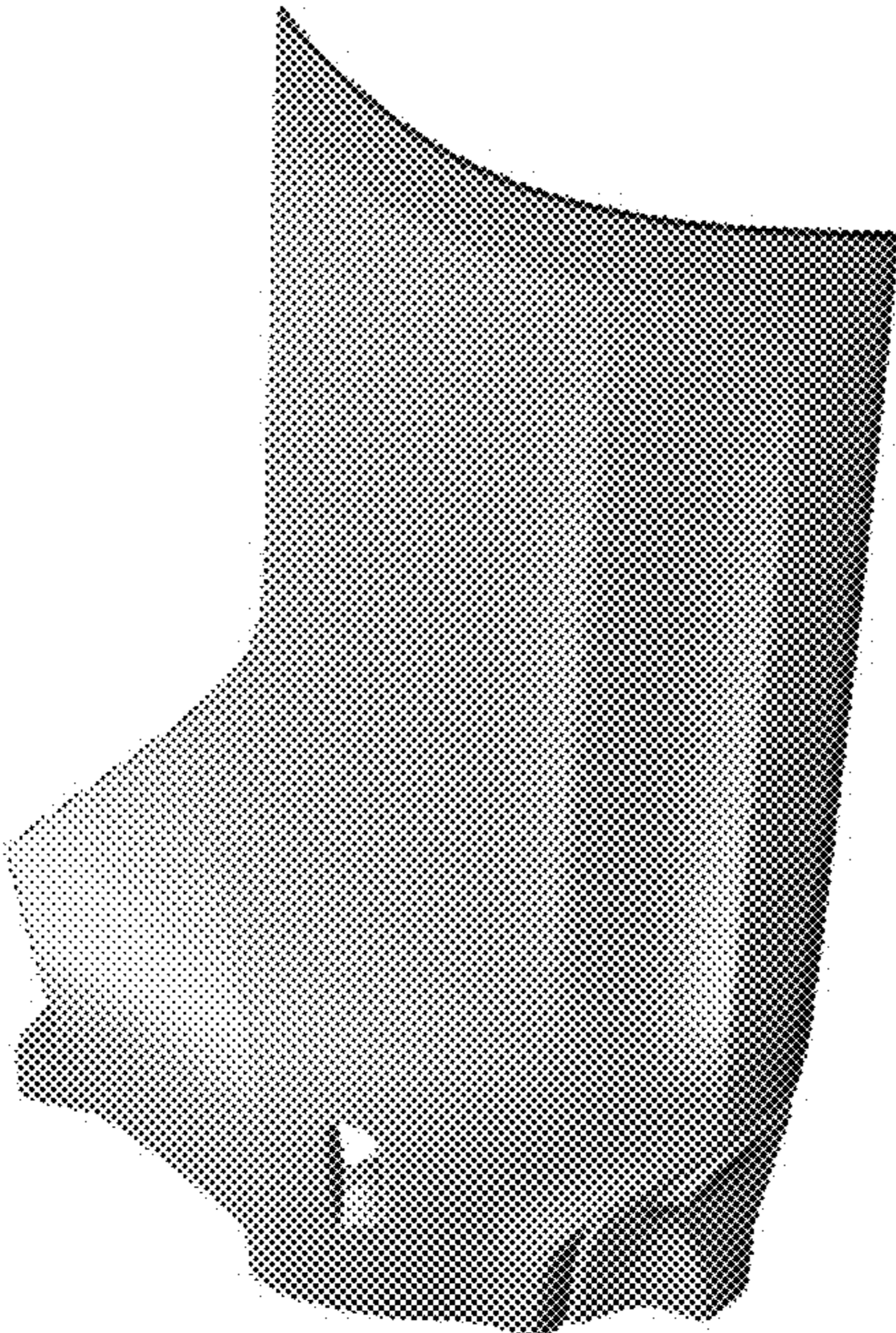

FIG. 4

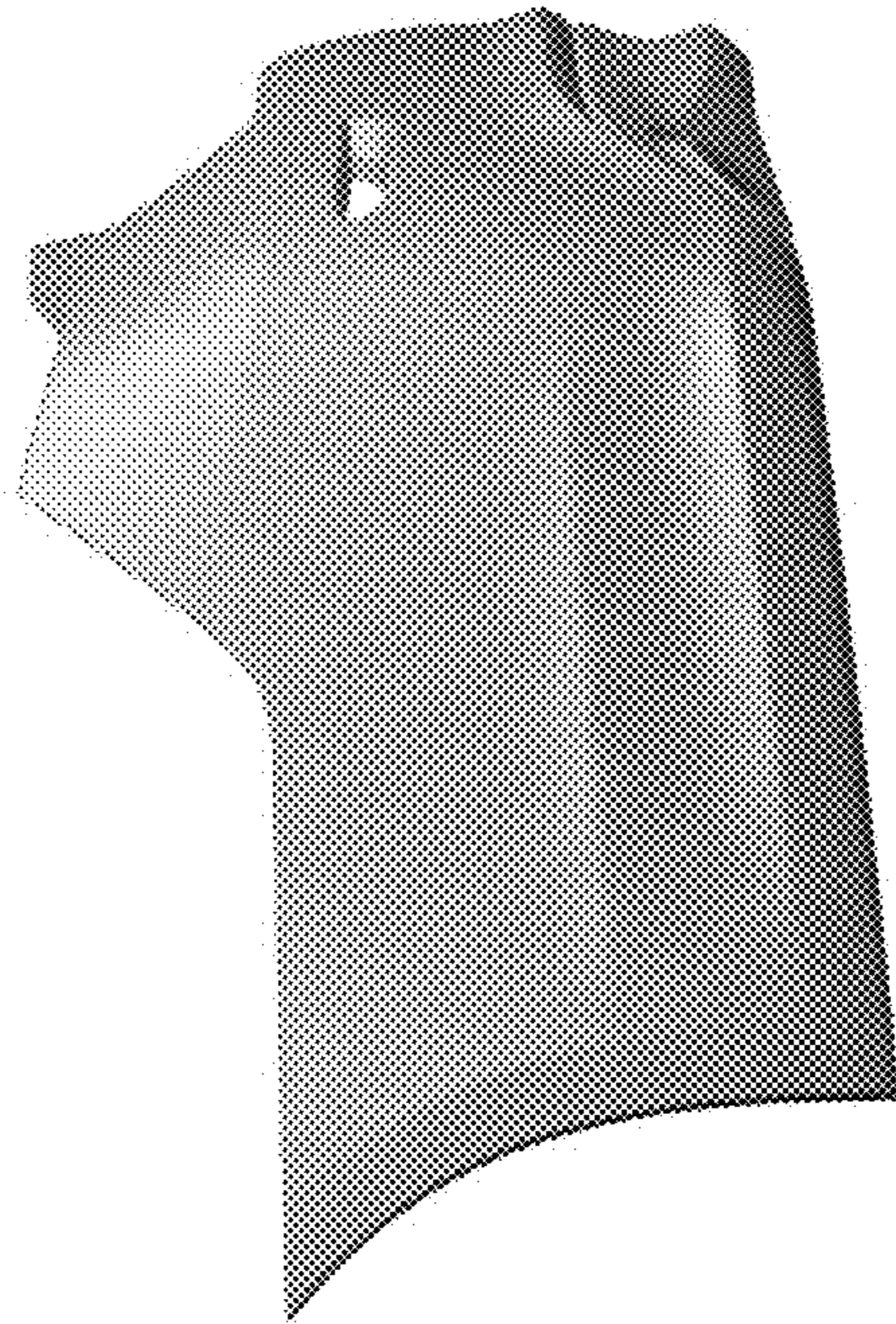

FIG. 5

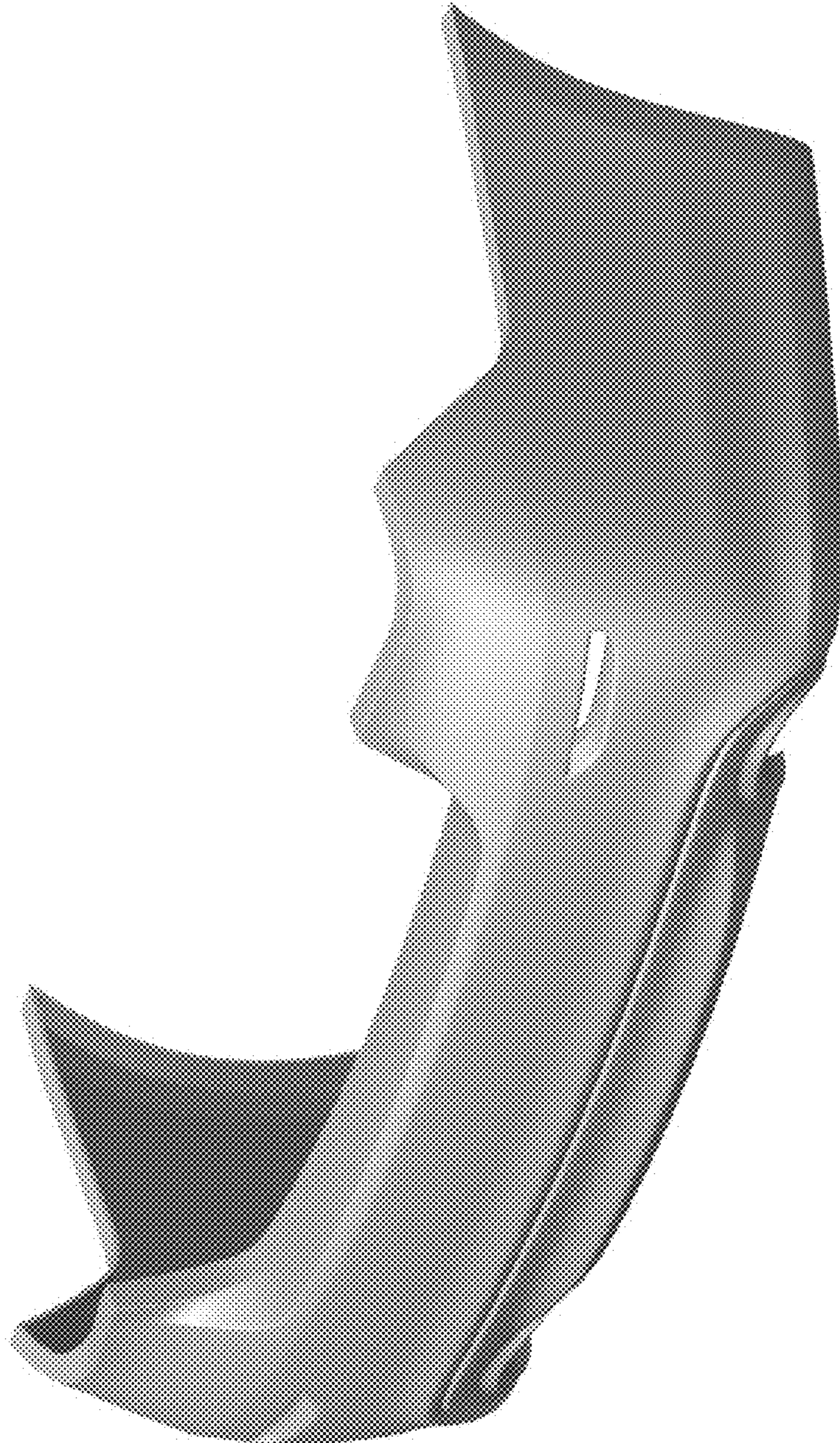

FIG. 6

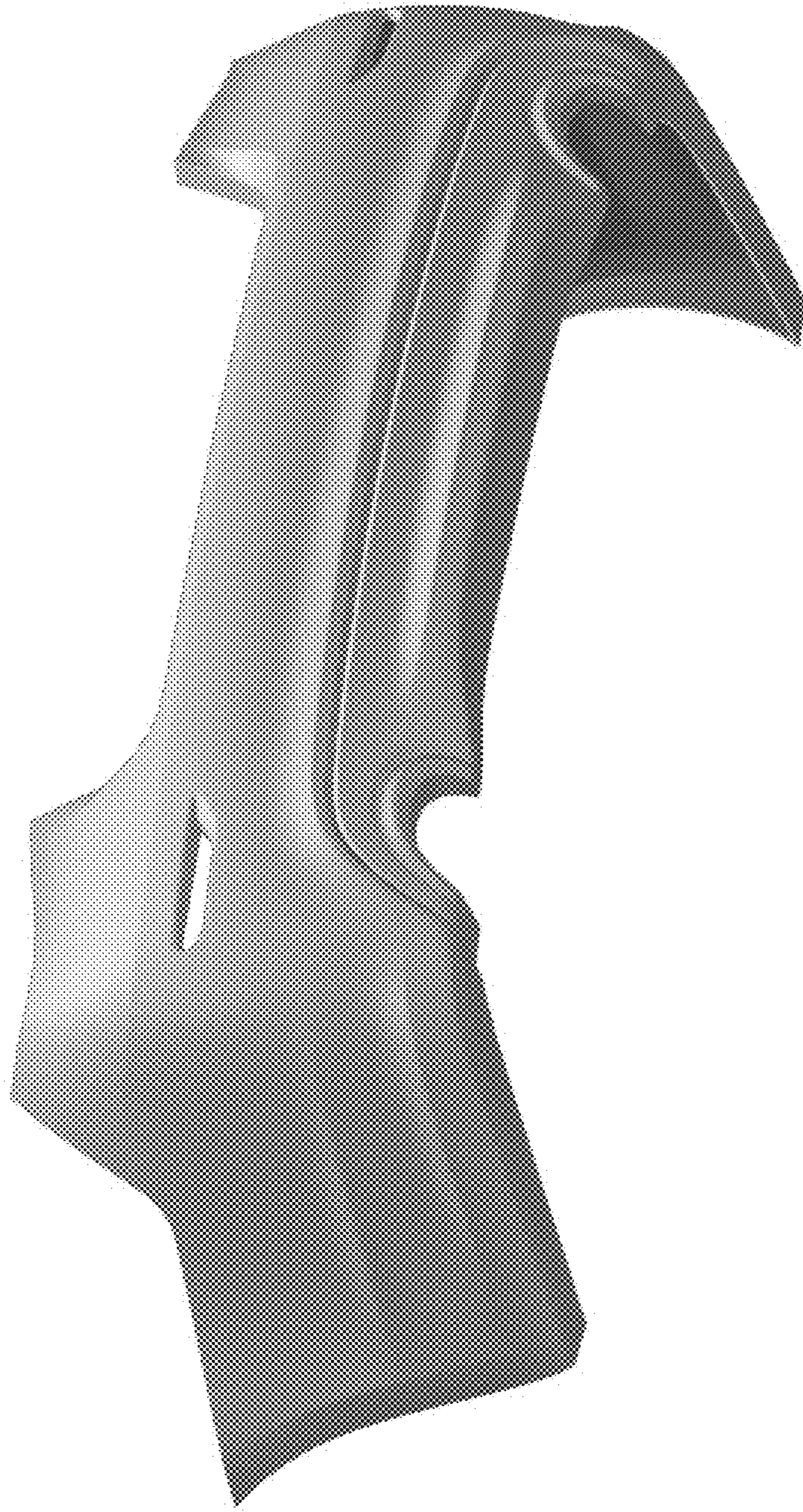

FIG. 7