



US00D746177S

(12) **United States Design Patent**
Broen et al.

(10) **Patent No.:** **US D746,177 S**
(45) **Date of Patent:** **** Dec. 29, 2015**

- (54) **CART**
- (71) Applicant: **PepsiCo, Inc.**, Purchase, NY (US)
- (72) Inventors: **Martin Eduardo Broen**, New York, NY (US); **Christopher Erlin Granneberg**, Brooklyn, NY (US)
- (73) Assignee: **PepsiCo, Inc.**, Purchase, NY (US)
- (**) Term: **14 Years**
- (21) Appl. No.: **29/493,753**
- (22) Filed: **Jun. 12, 2014**
- (51) **LOC (10) Cl.** **12-10**
- (52) **U.S. Cl.**
USPC **D12/102; D34/20**
- (58) **Field of Classification Search**
USPC D12/101, 102, 105, 114; 280/204, 656, 280/789; D34/12-27; 312/249.1, 249.11; 235/385; 705/23
CPC B62B 5/0003; B62B 5/0079; B62H 3/02
See application file for complete search history.

D573,514	S	*	7/2008	Liu	D12/102
D623,312	S	*	9/2010	Tafel	D25/16
8,505,932	B1	*	8/2013	Piccirillo	280/30
D698,700	S	*	2/2014	Dempsey et al.	D12/101
D698,701	S	*	2/2014	Dempsey et al.	D12/101
2002/0180228	A1	*	12/2002	Poarch et al.	296/22
2009/0184488	A1	*	7/2009	Dixon	280/202
2014/0091551	A1	*	4/2014	Walter	280/267

OTHER PUBLICATIONS

“2 Wheels and A Bad Foot in Amsterdam—Part 3.” I Love Biking SF & OAK., May 25, 2013 [online], [retrieved on Aug. 4, 2015]. Retrieved from the Internet <URL: <http://ilovebikingsf.com/2013/05/25/2-wheels-and-a-bad-foot-in-amsterdam-part-3/>>.*

Jackson, Lisa. “The Coolest Bike Food Carts.” Jetsetta., Nov. 11, 2010 [online], [retrieved on Aug. 4, 2015]. Retrieved from the Internet <URL: <http://jetsetta.com/the-coolest-bike-food-carts/>>.*

(Continued)

Primary Examiner — Philip S Hyder
Assistant Examiner — Darlington Ly
(74) *Attorney, Agent, or Firm* — Sterne, Kessler, Goldstein & Fox P.L.L.C.

(57) **CLAIM**
The ornamental design for a cart, as shown and described.

DESCRIPTION

FIG. 1 is a top, front, right perspective view of a cart showing our new design;
FIG. 2 is a right side view thereof;
FIG. 3 is a front view thereof;
FIG. 4 is a left side view thereof;
FIG. 5 is a top view thereof; and,
FIG. 6 is a top, rear, left perspective view thereof.
The broken line showing portions of the cart and environmental structure of a tricycle forms no part of the claimed design.

1 Claim, 6 Drawing Sheets

(56) **References Cited**

U.S. PATENT DOCUMENTS

1,962,454	A	*	6/1934	Meanor et al.	126/268
D194,694	S	*	2/1963	Nagy	D21/425
3,724,873	A	*	4/1973	Glamb et al.	280/203
3,843,164	A	*	10/1974	Flegel	280/492
D304,813	S	*	11/1989	Kelly	D12/113
5,020,814	A	*	6/1991	George et al.	280/204
5,123,668	A	*	6/1992	Ligas	280/204
D340,429	S	*	10/1993	Smith	D12/102
D351,575	S	*	10/1994	Fenton et al.	D12/102
D368,680	S	*	4/1996	Freeman	D12/113
D383,094	S	*	9/1997	Mast	D12/102
5,810,378	A	*	9/1998	Brinkley	280/204
D547,812	S	*	7/2007	Seckel et al.	D21/425

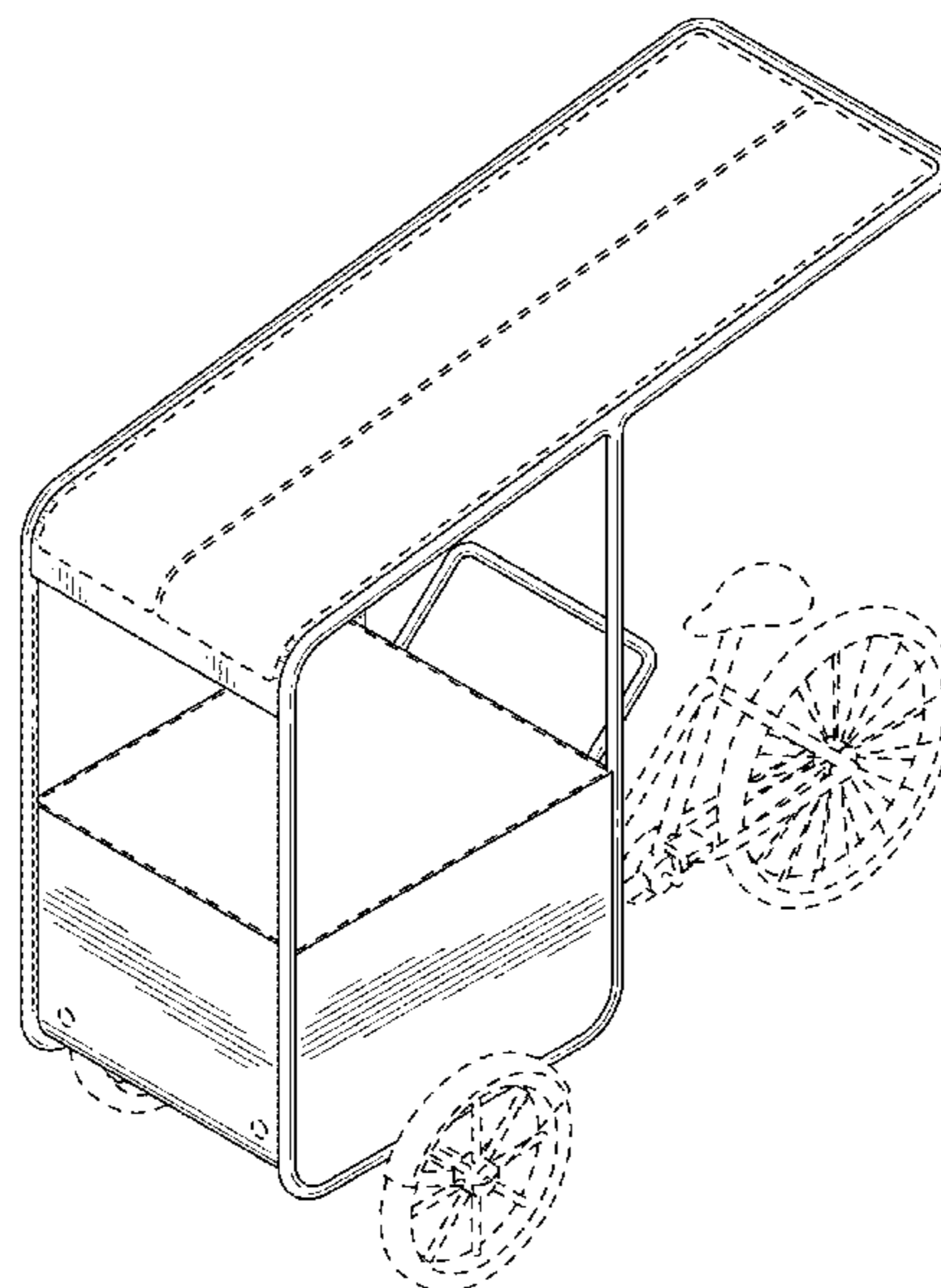

(56)

References Cited

OTHER PUBLICATIONS

Milionis, Allison. "Mobile Movement: Local Restaurants Go Mobile." Neighborhood Notes., Sep. 28, 2010 [online], [retrieved on Aug. 4, 2015]. Retrieved from the Internet <URL: http://www.neighborhoodnotes.com/news/2010/09/mobile_movement_local_restaurants_go_mobile/>.*

neighborhoodnotes.com/news/2010/09/mobile_movement_local_restaurants_go_mobile/>.*
"The Ice Cream Bike." Dream Maker Ice Cream Carts., Aug. 6, 2011 [online], [retrieved on Aug. 4, 2015]. Retrieved from the Internet <URL: <http://www.dreammakericecreamcarts.com/>>.*

* cited by examiner

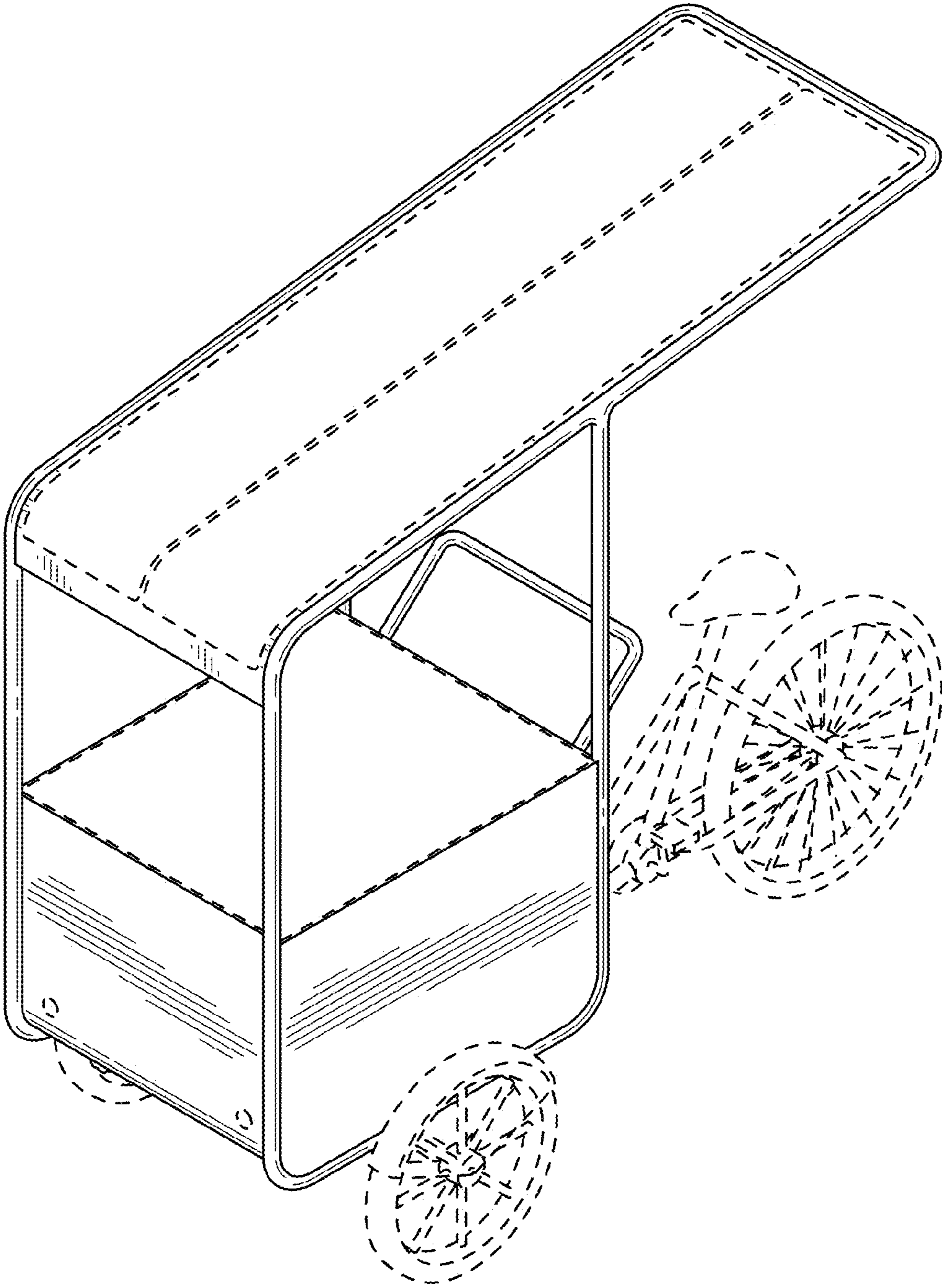

FIG. 1

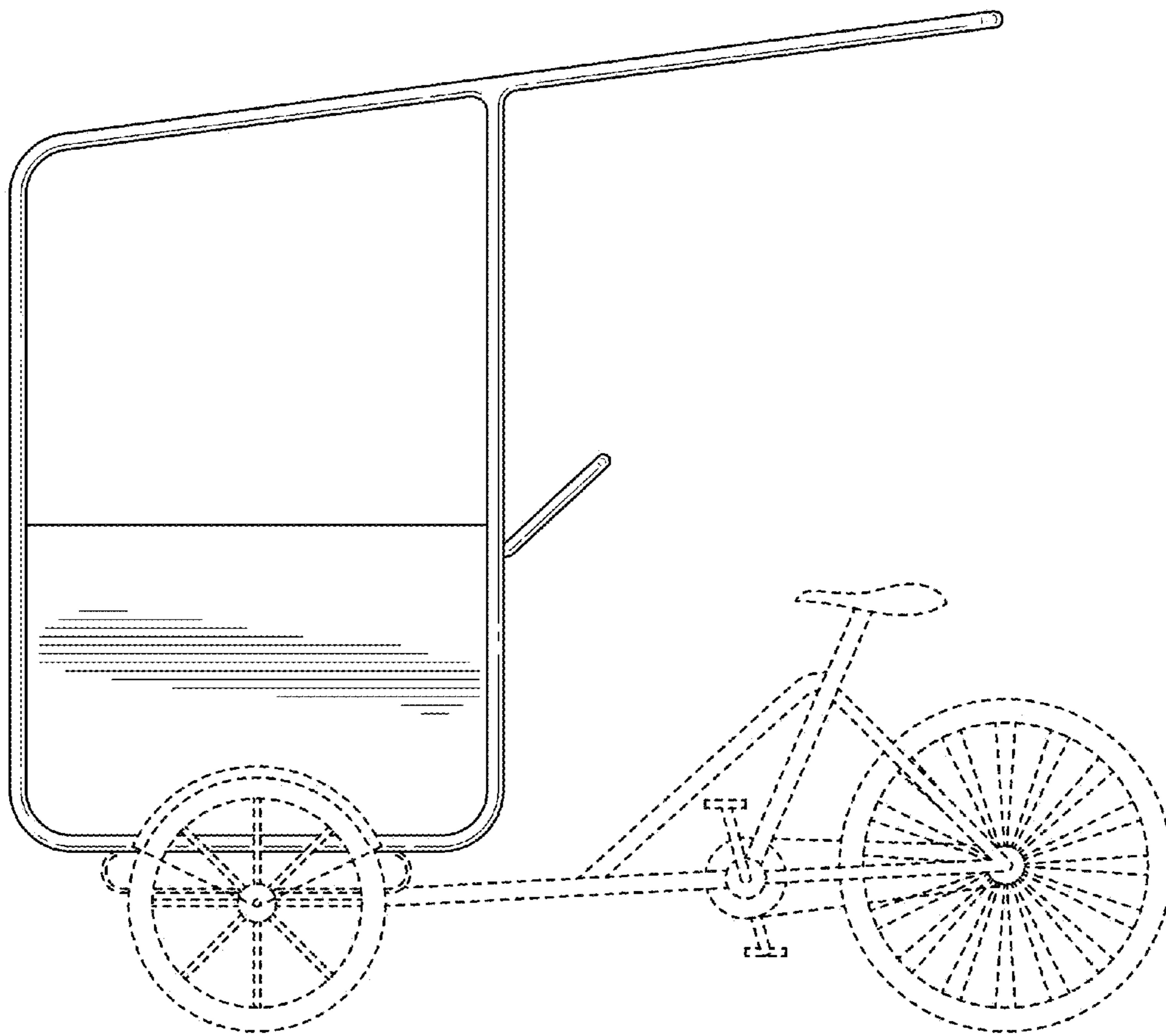

FIG. 2

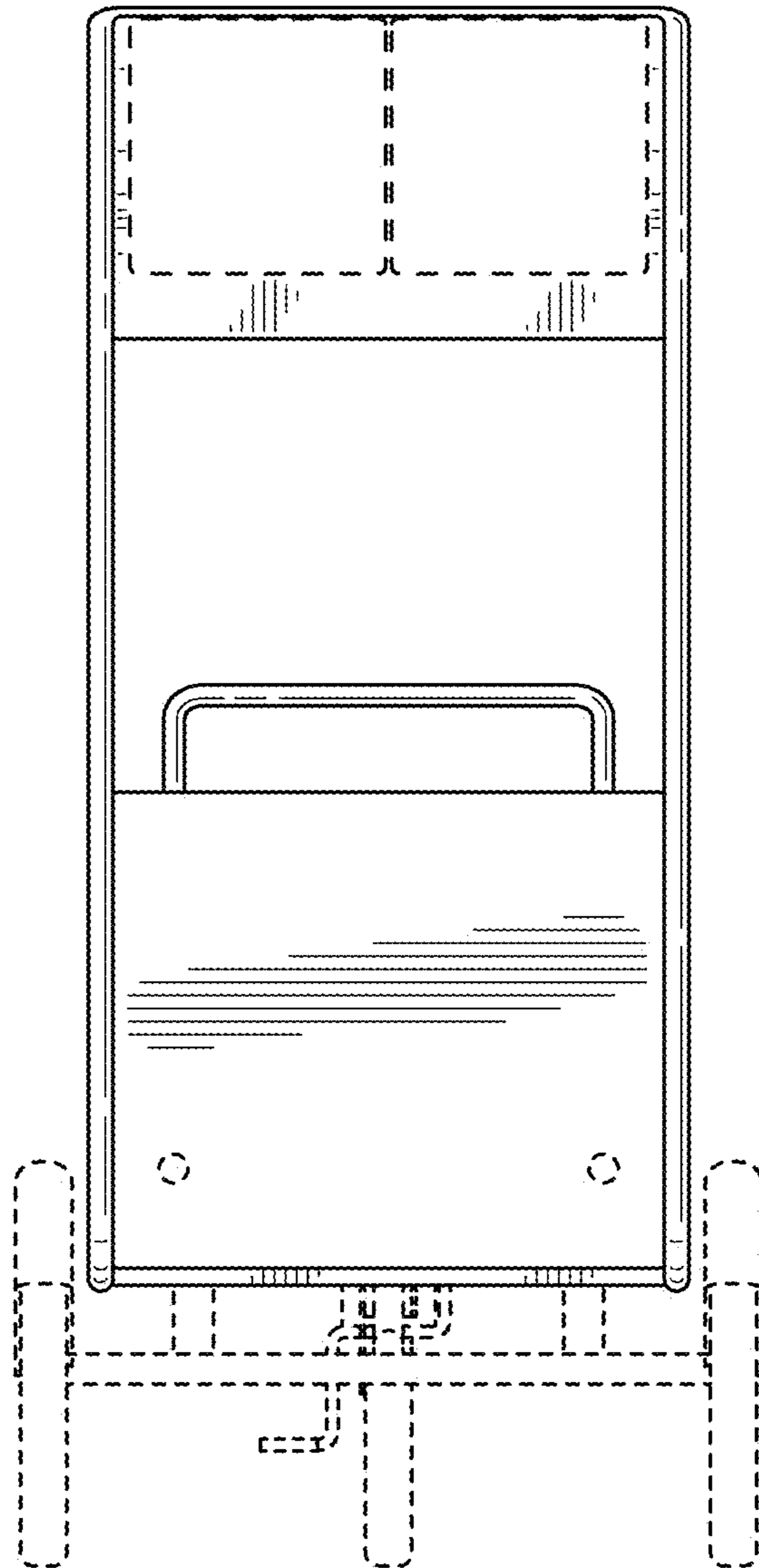

FIG. 3

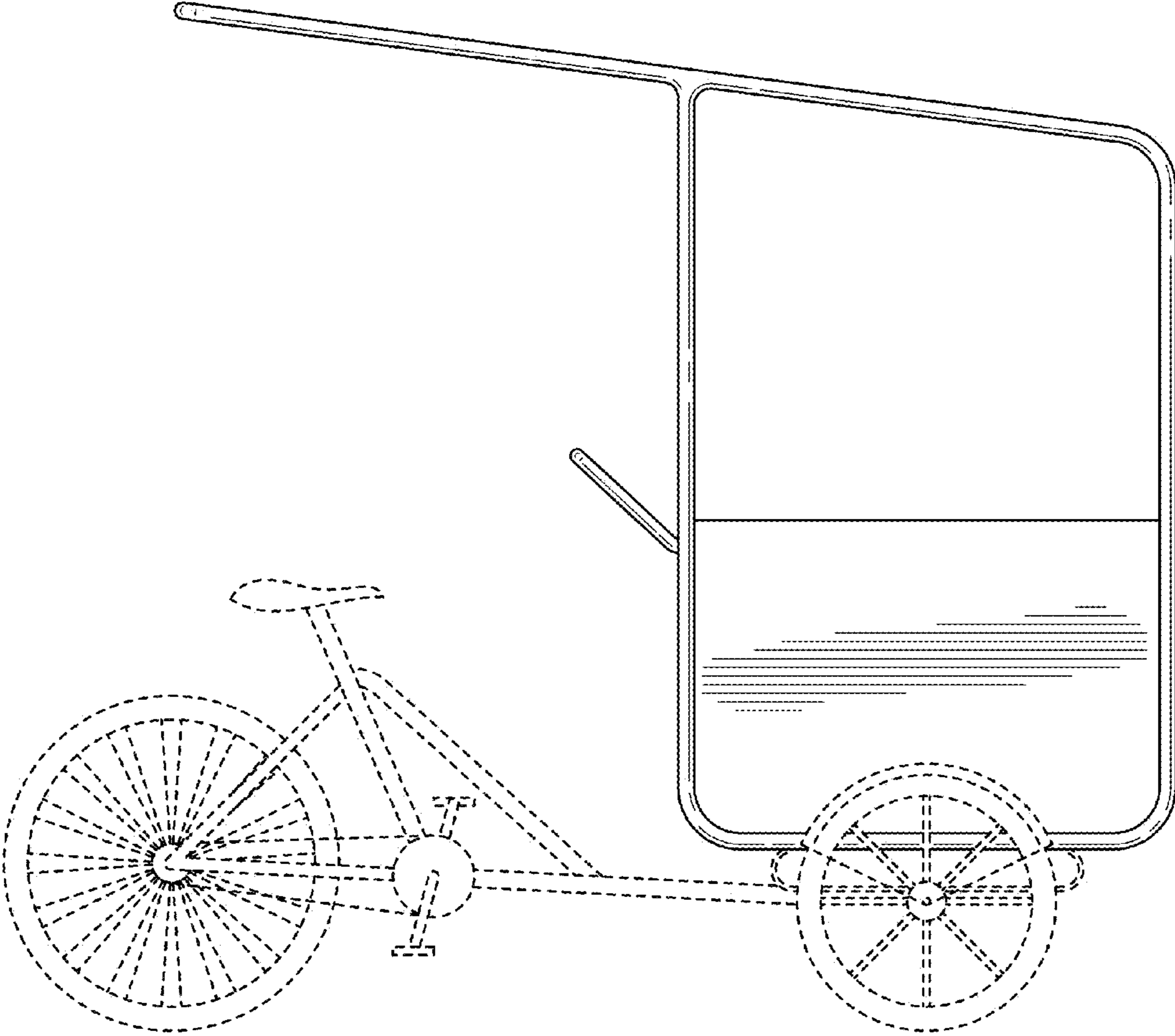

FIG. 4

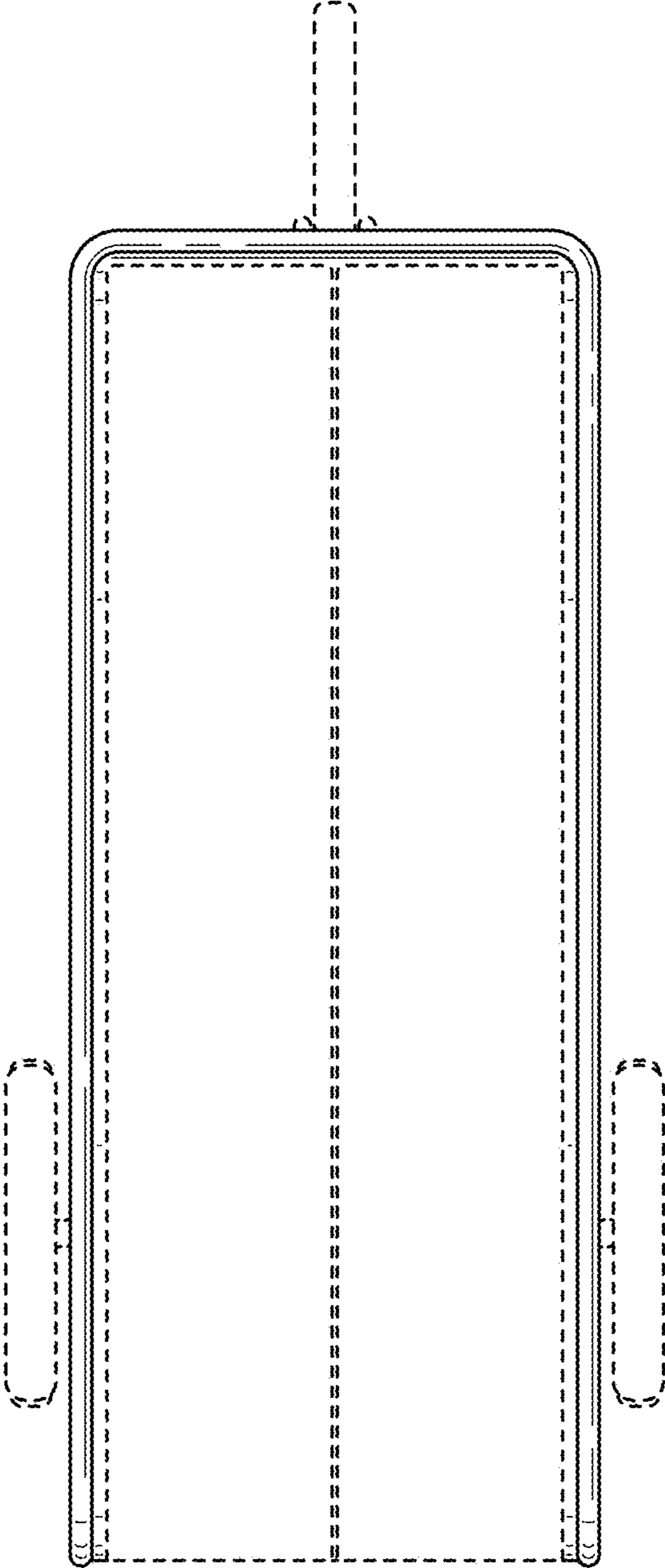

FIG. 5

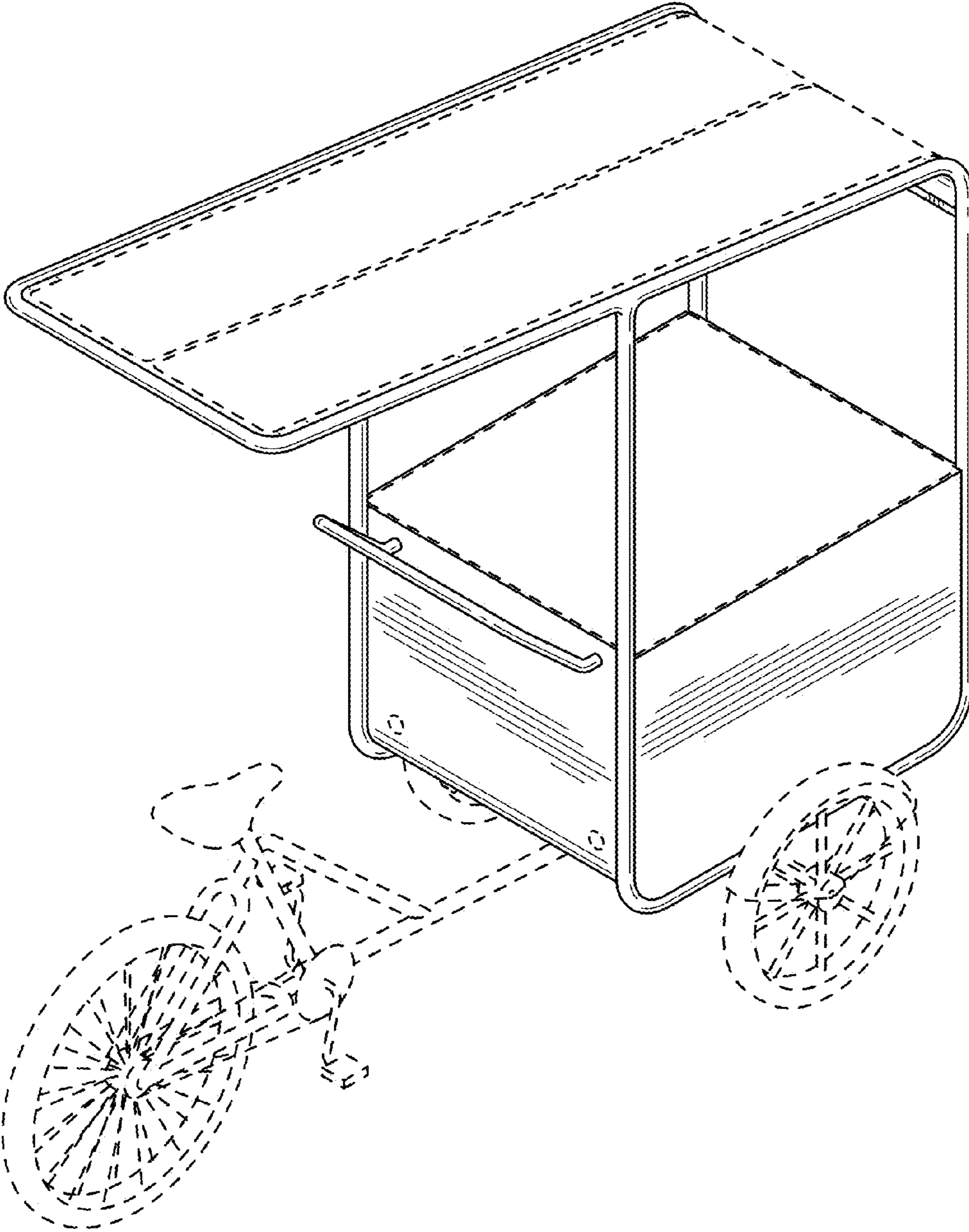

FIG. 6