



US00D746174S

(12) **United States Design Patent**  
**Storms**

(10) **Patent No.:** **US D746,174 S**

(45) **Date of Patent:** **\*\* Dec. 29, 2015**

(54) **GOLF CART REAR BODY**

(71) Applicant: **Jimmy Storms**, La Marque, TX (US)

(72) Inventor: **Jimmy Storms**, La Marque, TX (US)

(\*\*) Term: **14 Years**

(21) Appl. No.: **29/449,874**

(22) Filed: **Mar. 15, 2013**

(51) **LOC (10) Cl.** ..... **12-02**

(52) **U.S. Cl.**  
USPC ..... **D12/16**

(58) **Field of Classification Search**  
USPC ..... D12/16, 14, 1, 86, 90, 91, 92, 167, 169,  
D12/93, 107, 85, 87, 88, 82; 224/274;  
280/DIG. 5; 296/37.16; 180/233, 908,  
180/89.1, 89.11, 6.5  
See application file for complete search history.

(56) **References Cited**

**U.S. PATENT DOCUMENTS**

D464,913	S	*	10/2002	Cerny et al.	.....	D12/86
D493,749	S	*	8/2004	Duncan	.....	D12/16
D498,436	S	*	11/2004	Bonner et al.	.....	D12/16
D498,704	S	*	11/2004	Bonner et al.	.....	D12/16
D517,448	S	*	3/2006	Essig	.....	D12/16
7,240,948	B1	*	7/2007	Houston	.....	296/63
D584,187	S	*	1/2009	Rossello et al.	.....	D12/16
D589,398	S	*	3/2009	Tuo	.....	D12/16
D600,593	S	*	9/2009	Hanson et al.	.....	D12/16
7,585,010	B2	*	9/2009	Hardy et al.	.....	296/37.16
D617,681	S	*	6/2010	Tuo	.....	D12/16
D646,201	S	*	10/2011	Zhang	.....	D12/16
D652,349	S	*	1/2012	Kristensen	.....	D12/16
2005/0224539	A1	*	10/2005	Hardy et al.	.....	224/274
2006/0180383	A1	*	8/2006	Bataille et al.	.....	180/311
2006/0230869	A1	*	10/2006	Cosby et al.	.....	74/512

\* cited by examiner

*Primary Examiner* — Eric Goodman

*Assistant Examiner* — Clese Moore, Jr.

(74) *Attorney, Agent, or Firm* — Karen B. Tripp

(57) **CLAIM**

The ornamental design for a golf cart rear body, as shown and described.

**DESCRIPTION**

FIG. 1 is a perspective view of a rear golf cart body showing our design for a retrofitted or remanufactured golf cart with the rear seat on the same horizontal plane as the front seat.

FIG. 2 is an elevational side view of the rear golf cart body of FIG. 1.

FIG. 3 is a perspective view of the rear golf cart body of FIG. 1 with the remainder of the golf cart removed.

FIG. 4 is an elevational front end view of the rear golf cart body of FIG. 3.

FIG. 5 is an elevational rear end view of the rear golf cart body of FIG. 3.

FIG. 6 is an elevational side view of the rear golf cart body of FIG. 3.

FIG. 7 is an elevational side view of the opposing side of the rear golf cart body of FIG. 3.

FIG. 8 is a top or plan view of the rear golf cart body of FIG. 3; and,

FIG. 9 is a bottom view of the rear golf cart body of FIG. 3.

This design for a golf cart rear body is intended for retrofitted or remanufactured golf carts.

A characteristic feature of the design is that the rear seat of the golf cart is on the same horizontal plane as the front seat of the golf cart. The broken lines shown illustrate environmental structure and form no part of the claimed design.

**1 Claim, 8 Drawing Sheets**

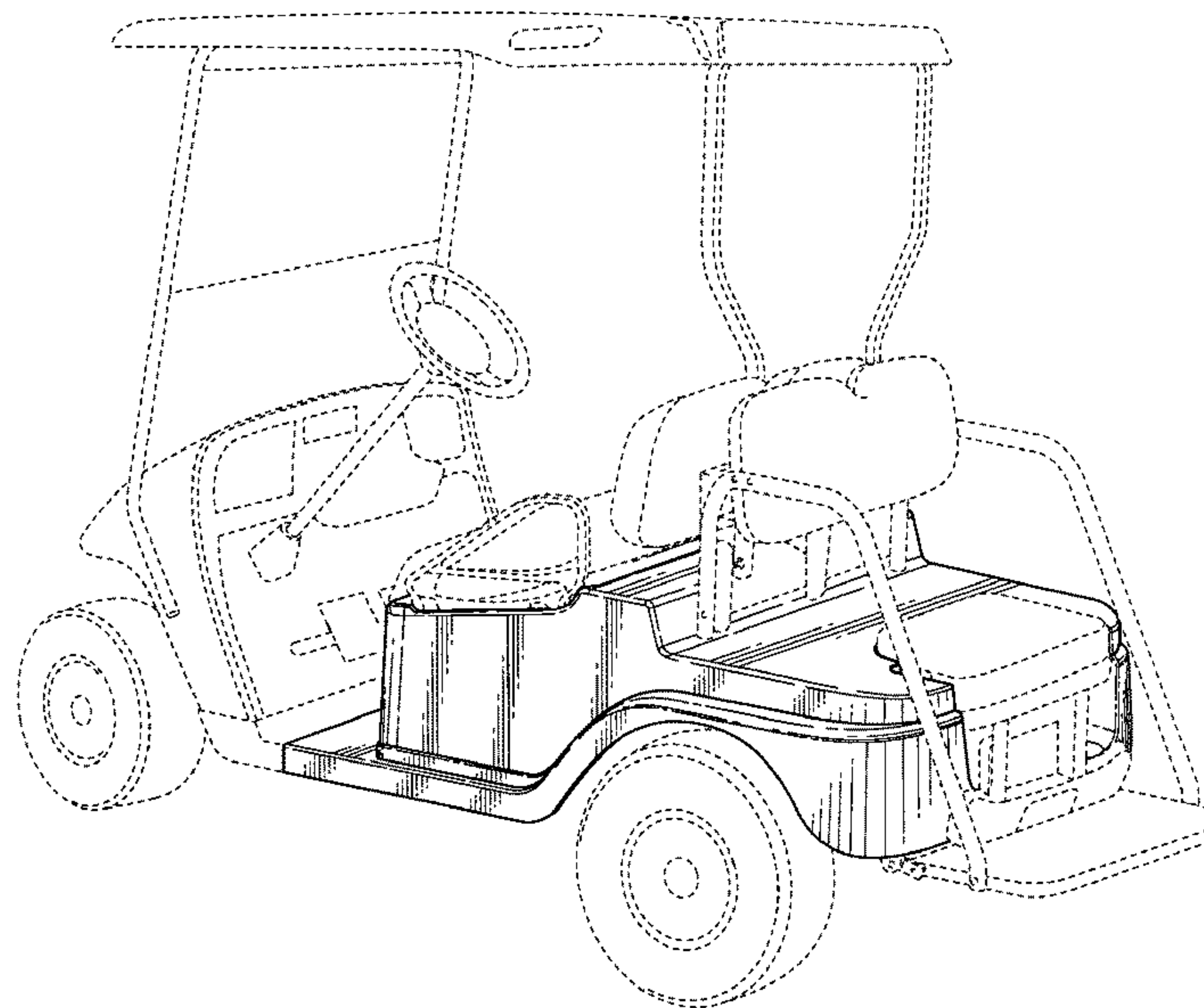

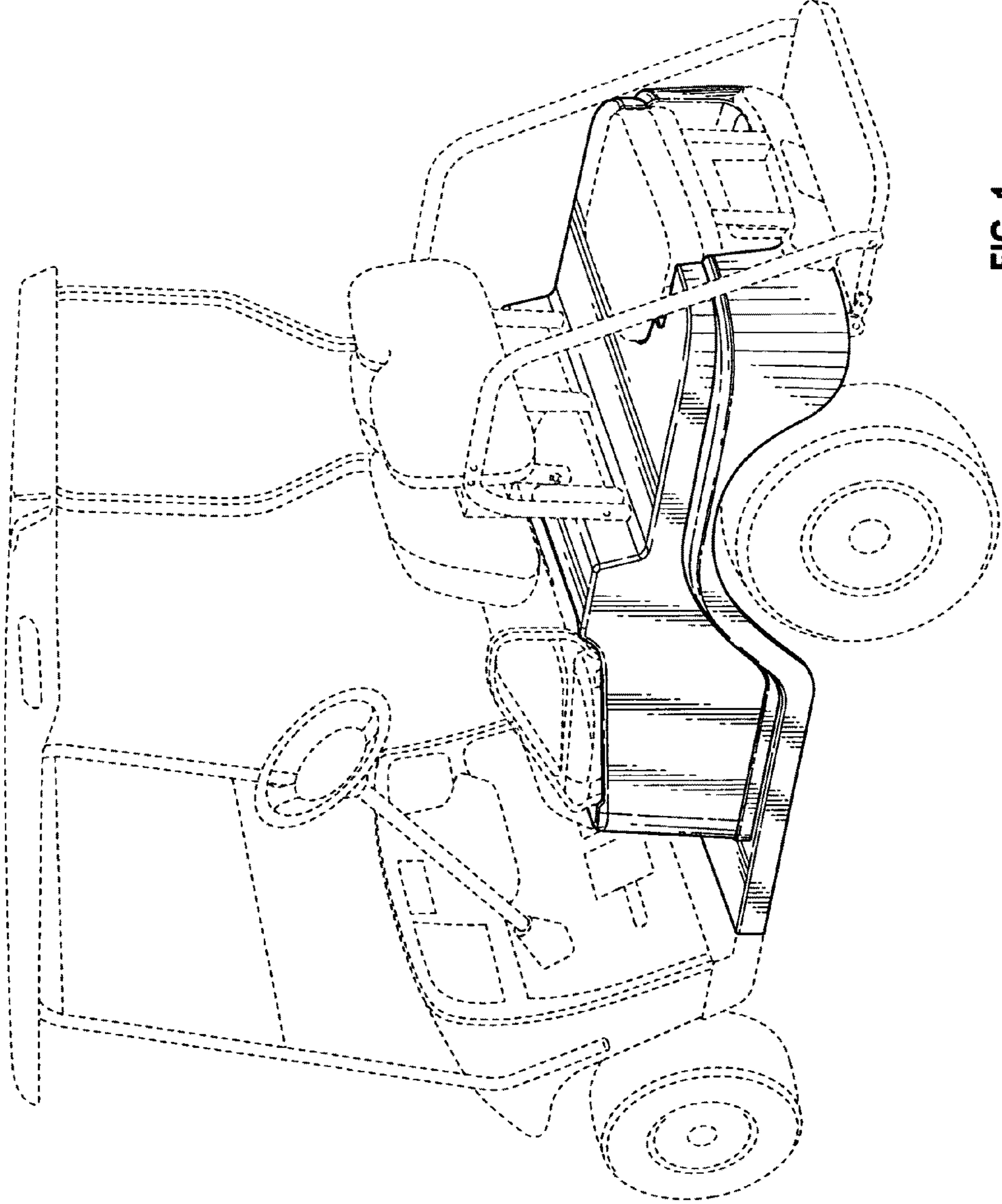

FIG. 1

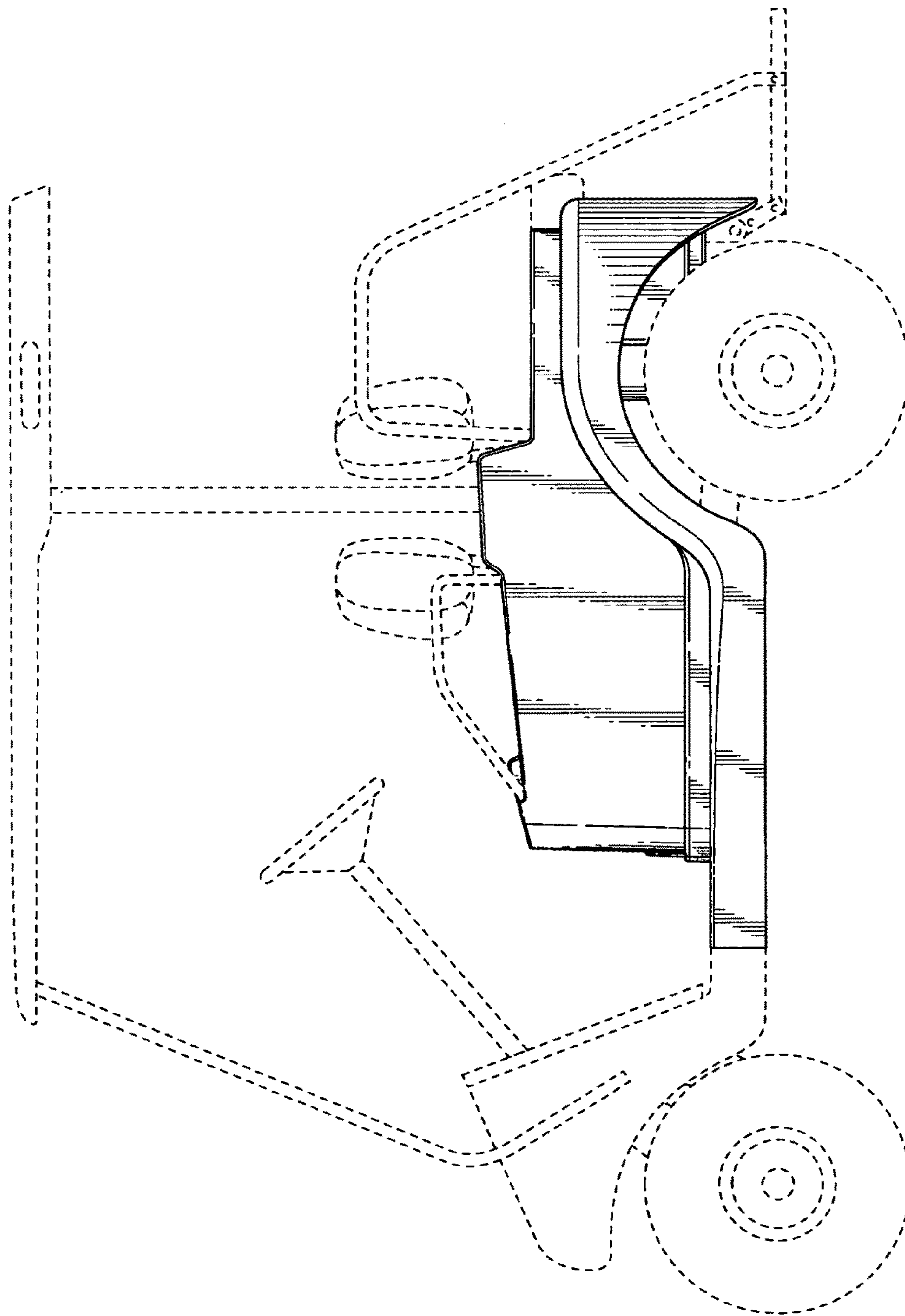

FIG. 2



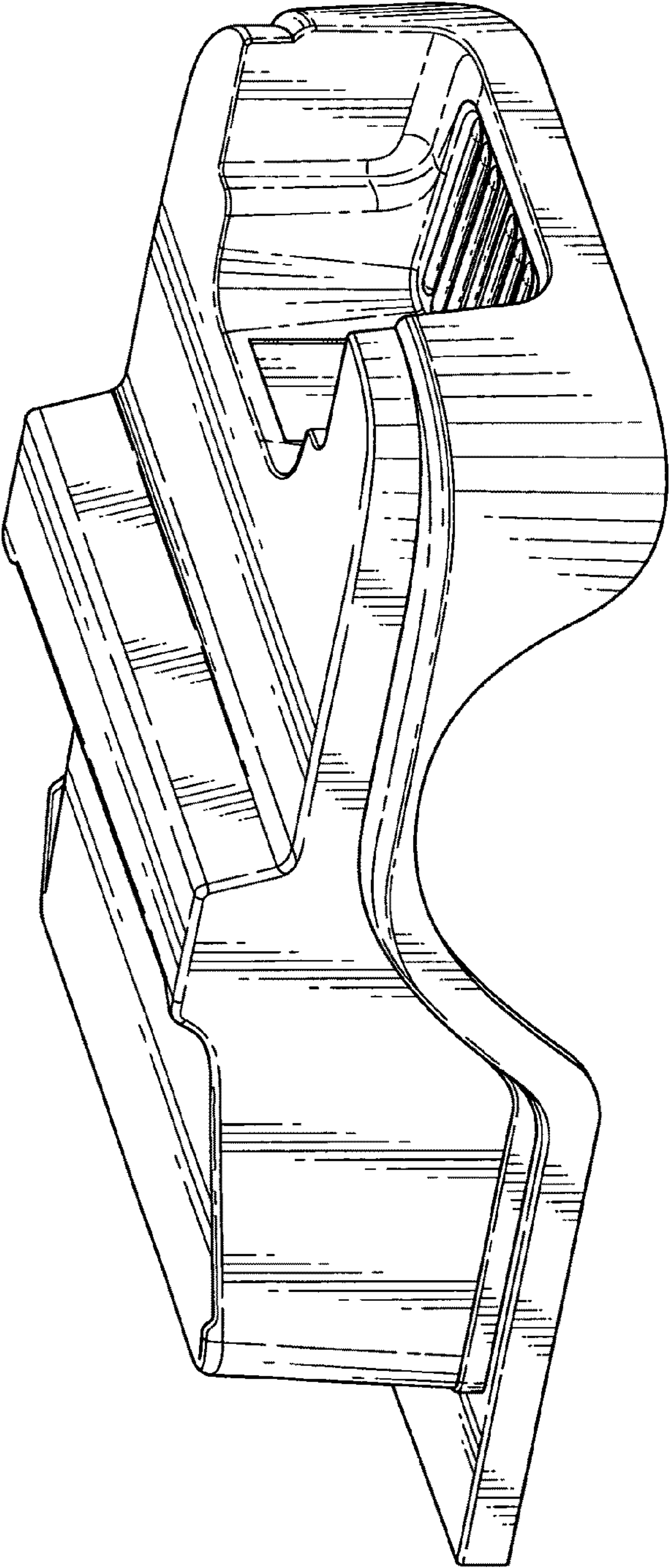

FIG. 3

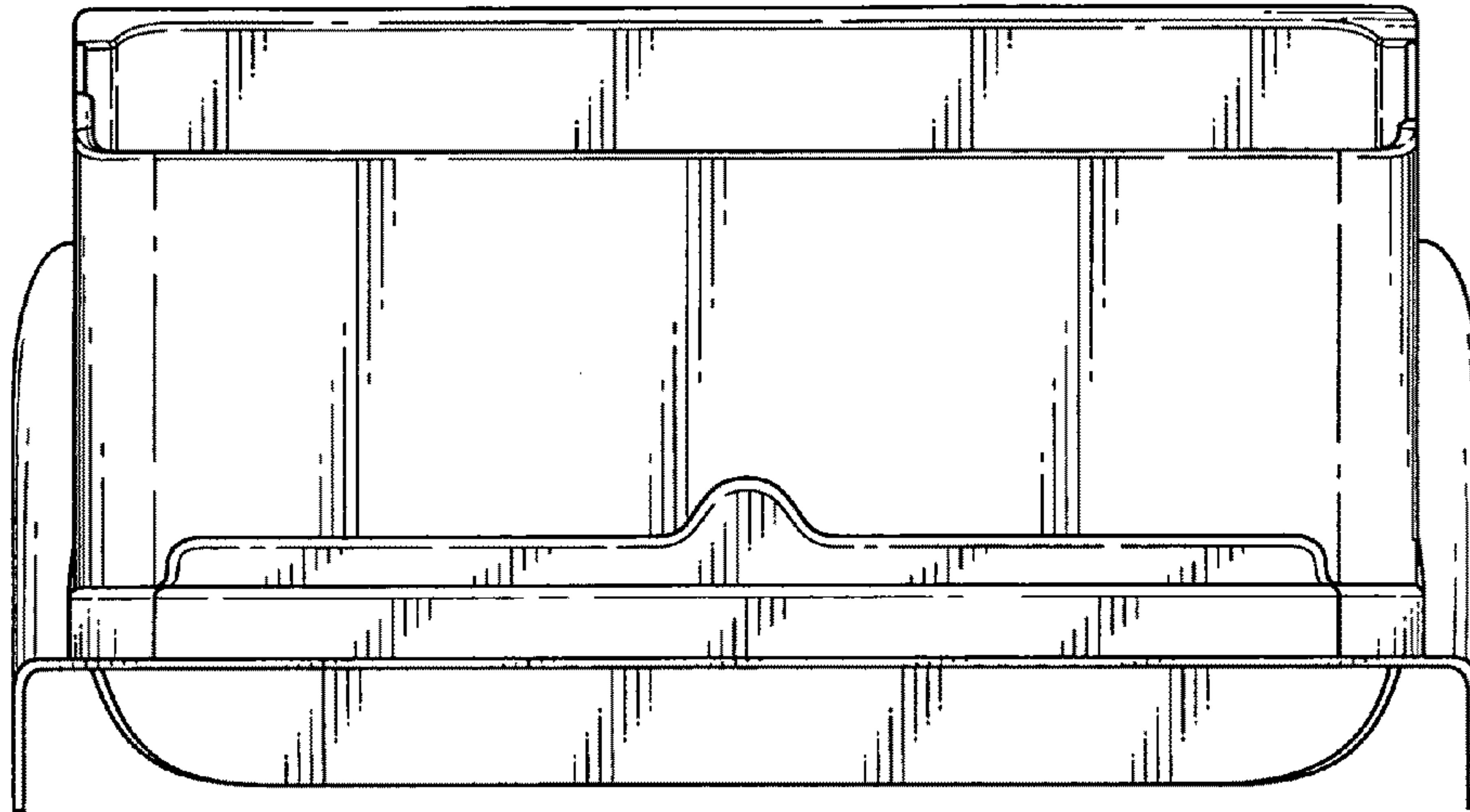

FIG. 4

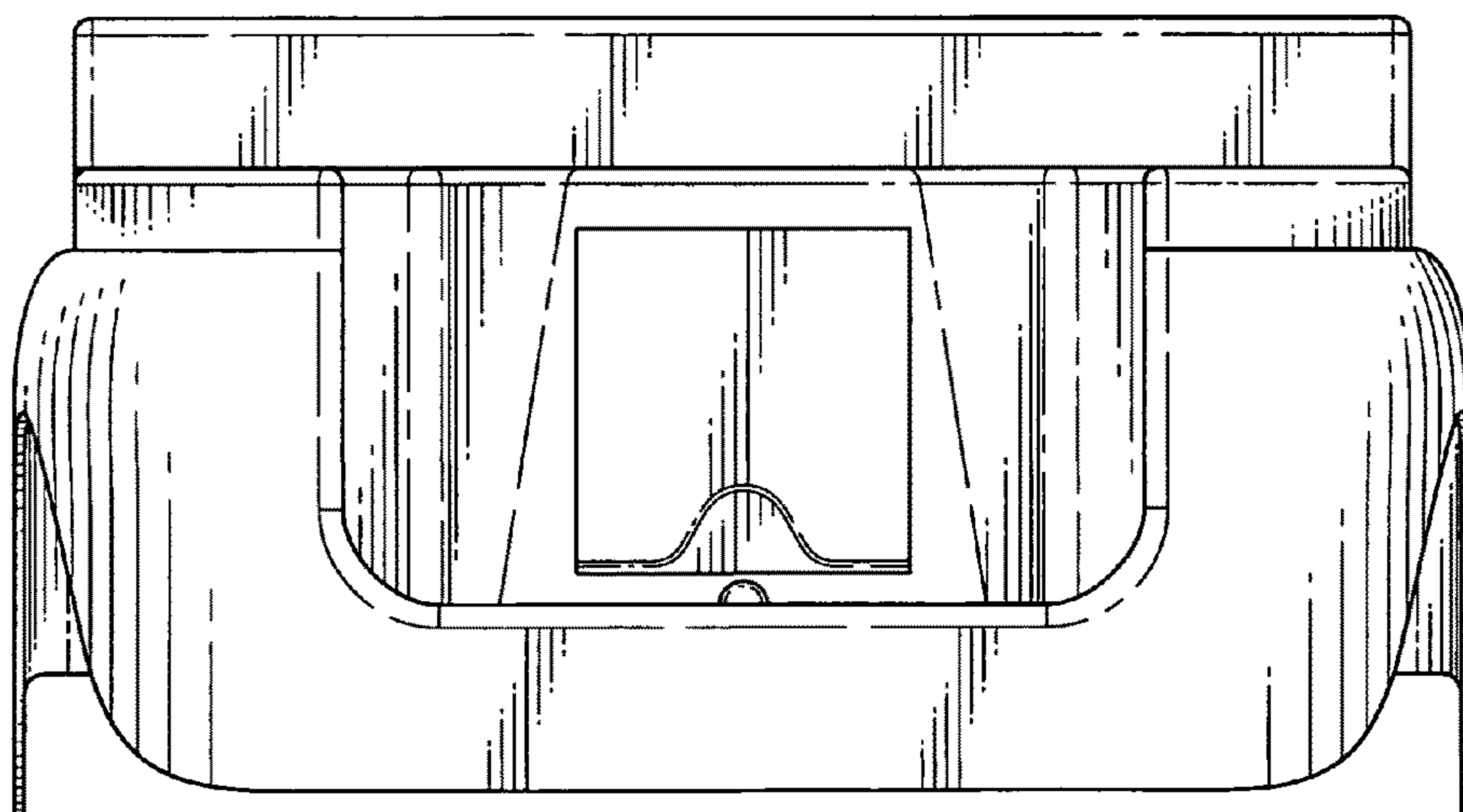

FIG. 5

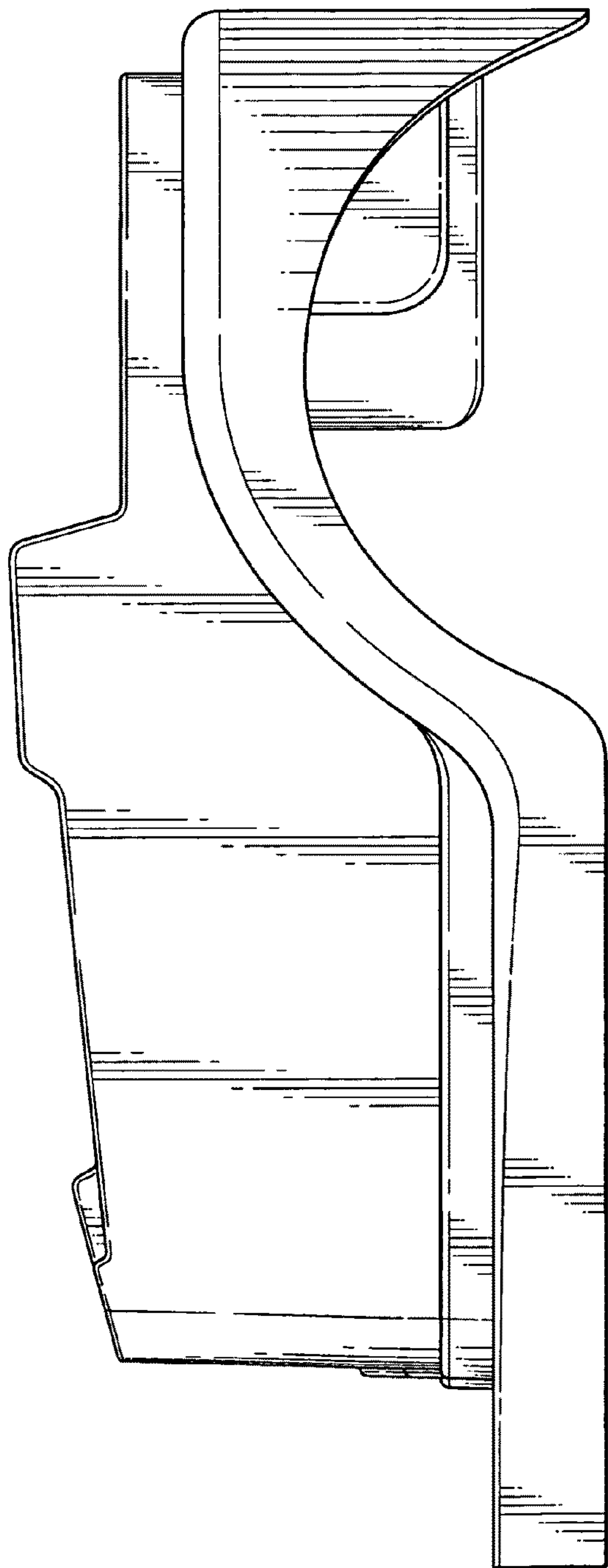

FIG. 6

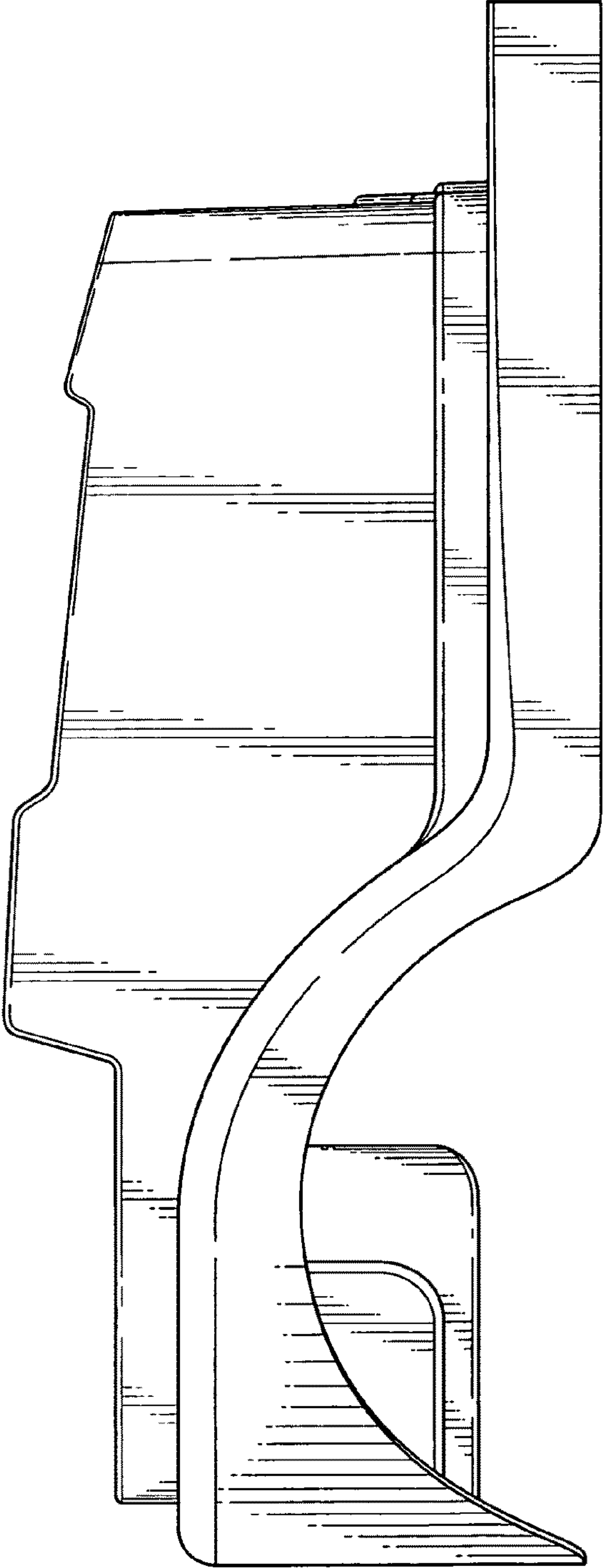

FIG. 7

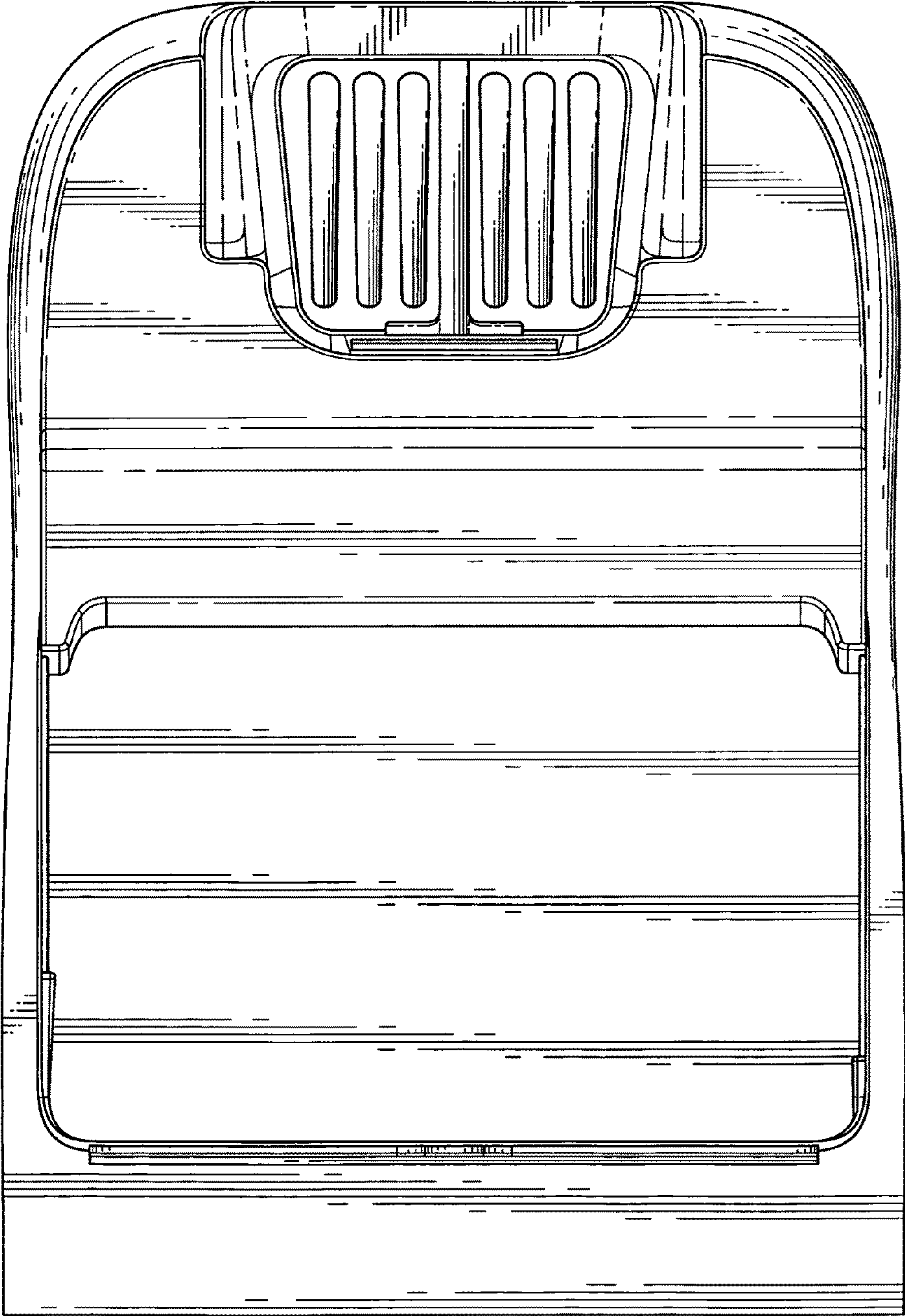

FIG. 8



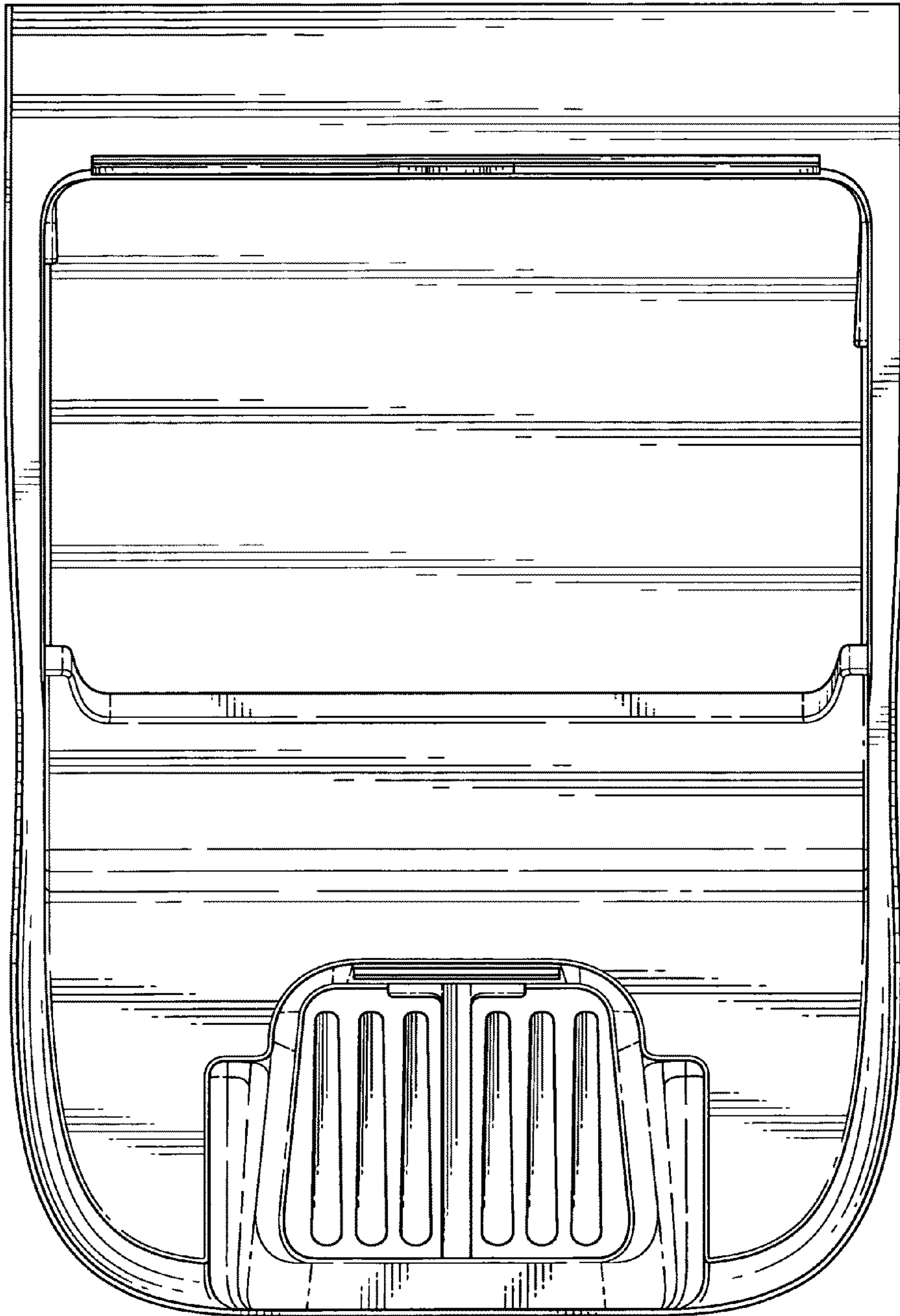

FIG. 9