



US00D745923S

(12) **United States Design Patent**
Trifilio

(10) **Patent No.:** **US D745,923 S**

(45) **Date of Patent:** **** Dec. 22, 2015**

- (54) **GUITAR EFFECTS PEDALBOARD**
- (71) Applicant: **Christian Richard Trifilio**, St Paul, MN (US)
- (72) Inventor: **Christian Richard Trifilio**, St Paul, MN (US)
- (73) Assignee: **Chemistry Design Werks LLC**, St. Paul, MN (US)

D588,830	S	*	3/2009	Chochinov et al.	D6/406.3
D609,027	S	*	2/2010	Jennings	D6/406.5
D619,823	S	*	7/2010	Jennings	D6/406.3
D620,761	S	*	8/2010	Boudreau	D7/549
D640,883	S	*	7/2011	Colfer et al.	D6/397
D690,708	S	*	10/2013	Smith et al.	D14/447
8,614,385	B2	*	12/2013	McKinney et al.	84/453
8,642,870	B1	*	2/2014	Rosa	84/453
D724,343	S	*	3/2015	Sinha	D6/406.3
2003/0230220	A1	*	12/2003	Evans et al.	108/43
2014/0077723	A1	*	3/2014	Ahern	315/299

- (**) Term: **14 Years**
- (21) Appl. No.: **29/472,202**

FOREIGN PATENT DOCUMENTS

AU	2012100641	A4	*	6/2012	G10H 1/32
WO	WO 2014114833	A1	*	7/2014	G10H 1/34

- (22) Filed: **Nov. 9, 2013**
- (51) **LOC (10) Cl.** **17-03**
- (52) **U.S. Cl.**
USPC **D17/20**
- (58) **Field of Classification Search**
USPC D6/329, 641, 650, 707, 707.15, 707.2, D6/512, 513, 514; D17/4, 9, 20, 24, 99; D10/103; D19/99, 100, 192, 101; D7/550.1, 554.2, 554.3; D14/328, 432, D14/447, 299
CPC G10H 1/348; G10H 1/34; G11B 15/02; Y10S 224/929; A47B 23/002; A47B 23/00
See application file for complete search history.

* cited by examiner

Primary Examiner — Sheryl Lane

Assistant Examiner — Ieisha Price

(74) *Attorney, Agent, or Firm* — Adams Grumbles, LLP; Brittany Nanzig

(56) **References Cited**

U.S. PATENT DOCUMENTS

D354,636	S	*	1/1995	Cable	D6/406.4
D395,969	S	*	7/1998	Barlow-Lawson	D6/511
5,866,829	A	*	2/1999	Pecoraro	84/177
D426,409	S	*	6/2000	Clark et al.	D6/511
D443,434	S	*	6/2001	Tinsley	D6/406.4
D479,417	S	*	9/2003	Couture et al.	D6/511
D493,486	S	*	7/2004	Allen	D19/52
D499,575	S	*	12/2004	Chan	D6/406.3
7,293,751	B2	*	11/2007	Eriksson	248/346.01
D584,070	S	*	1/2009	Jennings	D6/406.3
D585,663	S	*	2/2009	Beckley	D6/437

(57) **CLAIM**

The ornamental design for a guitar effects pedalboard, as shown and described.

DESCRIPTION

FIG. 1 is a right side view of a guitar effects pedalboard.
 FIG. 2 is a front view thereof;
 FIG. 3 is a top view thereof;
 FIG. 4 is a back side view thereof;
 FIG. 5 is a bottom side view thereof;
 FIG. 6 is a perspective view thereof;
 FIG. 7 is an alternate perspective view thereof;
 FIG. 8 is an alternate perspective view thereof;
 FIG. 9 is an alternate perspective view thereof;
 FIG. 10 is an alternate configuration perspective view thereof;
 FIG. 11 is an alternate configuration perspective view thereof;
 and,
 FIG. 12 is exploded view thereof.

1 Claim, 4 Drawing Sheets

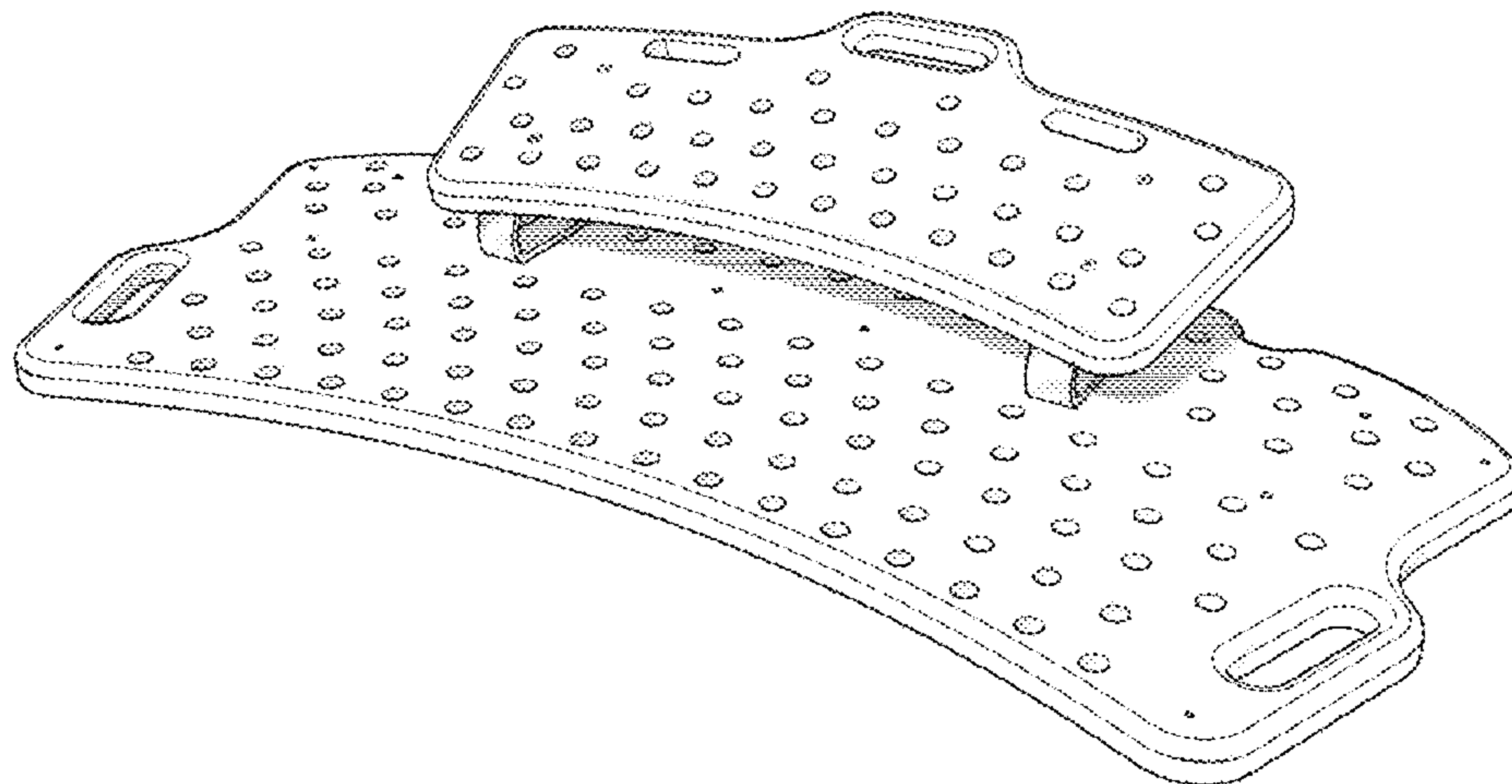

FIG. 1

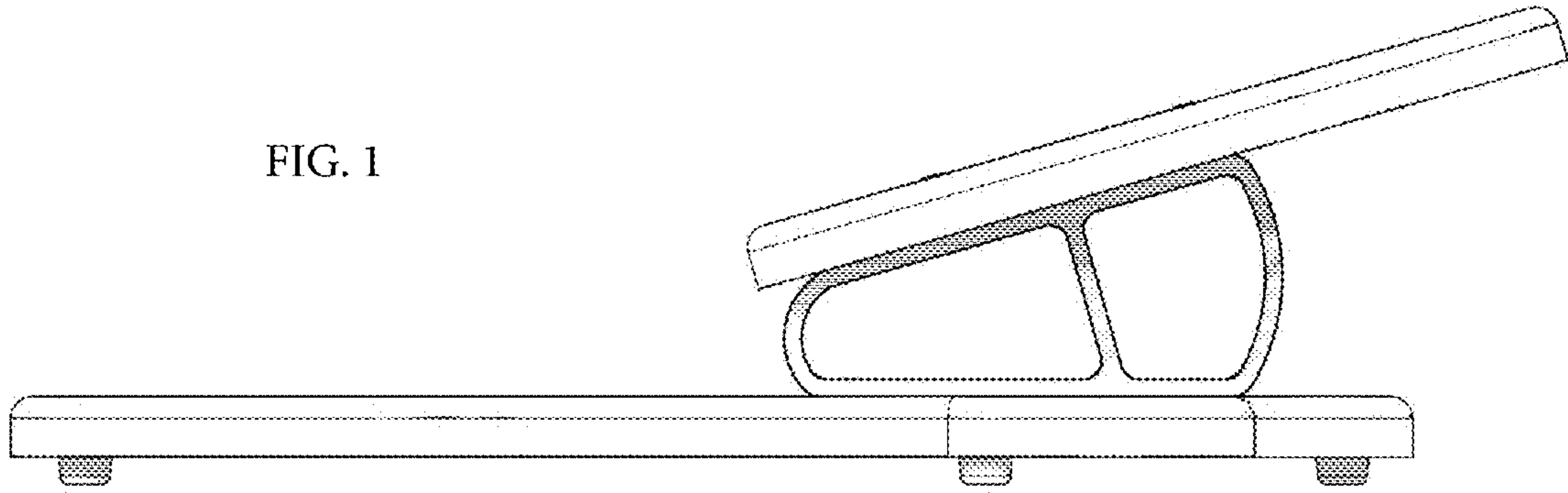

FIG. 2

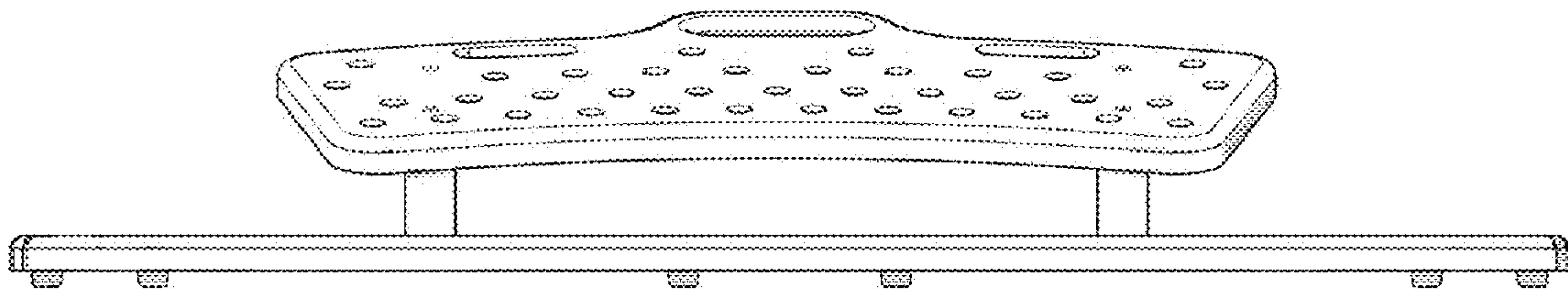

FIG. 3

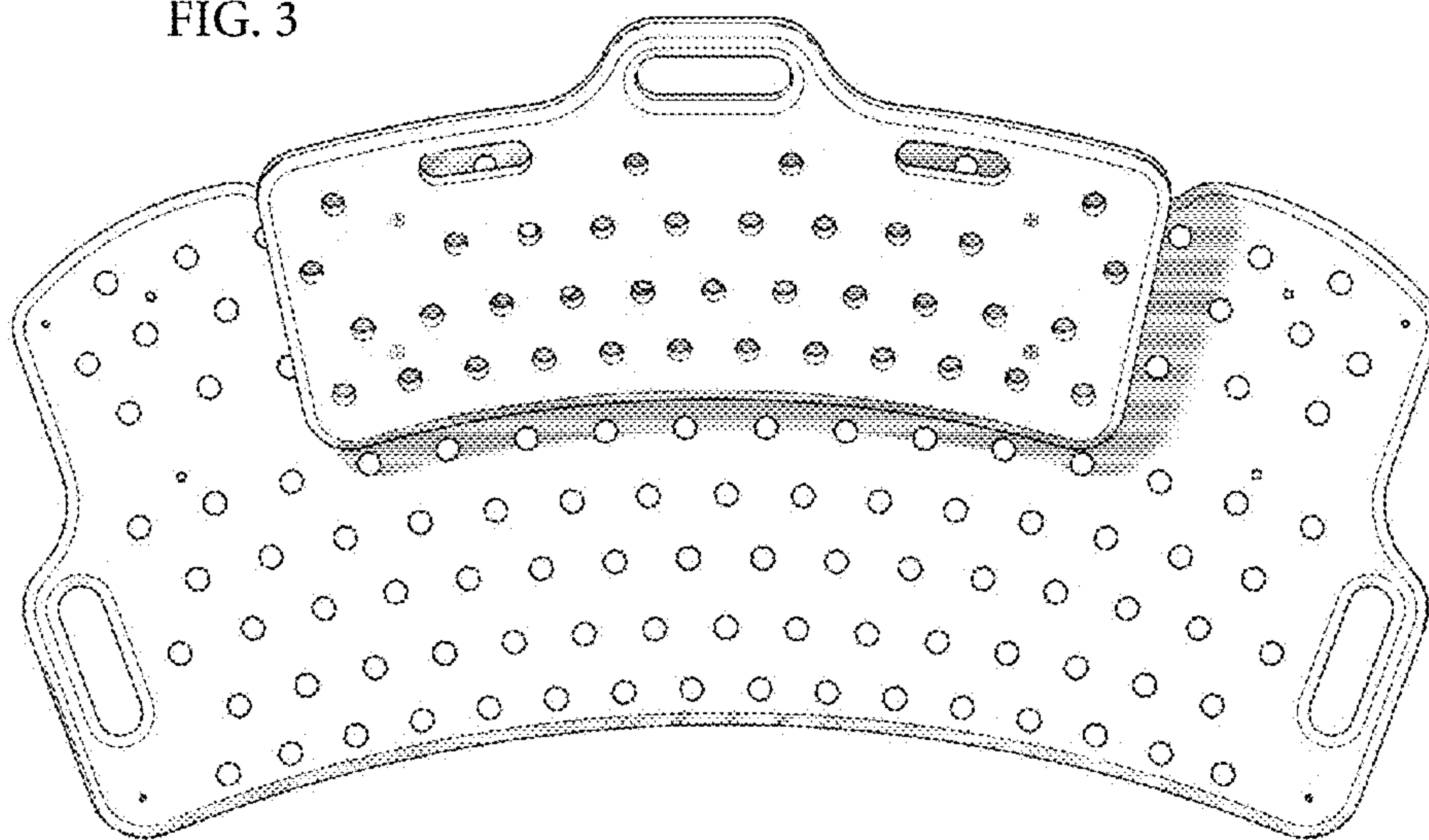

FIG. 4

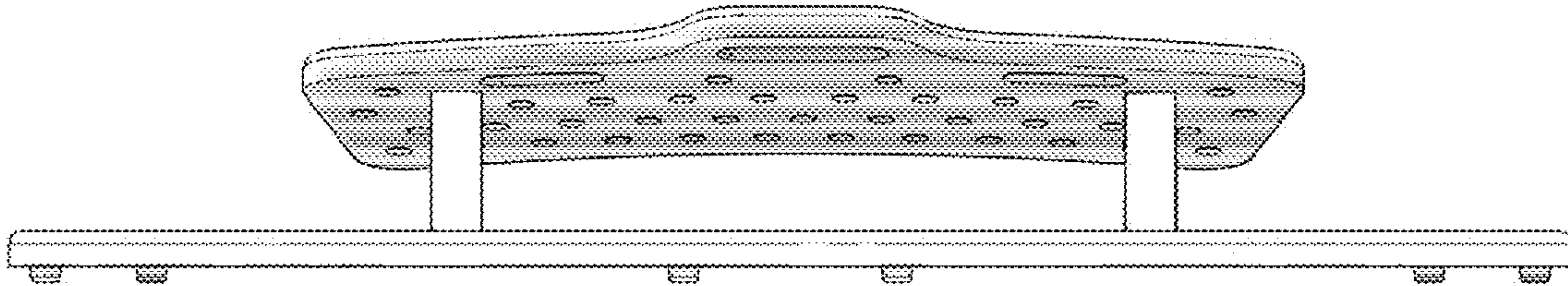

FIG. 5

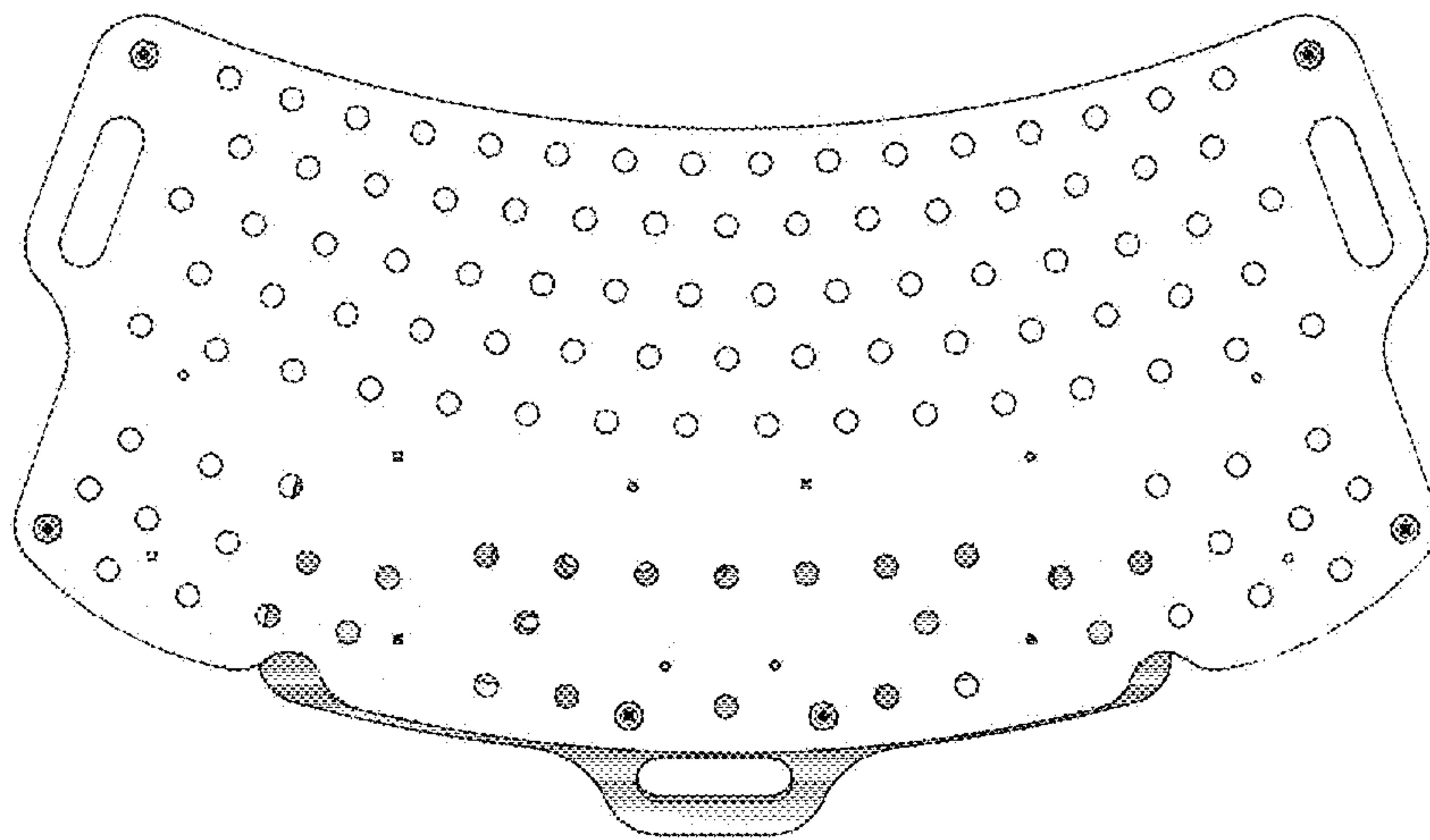

FIG. 6

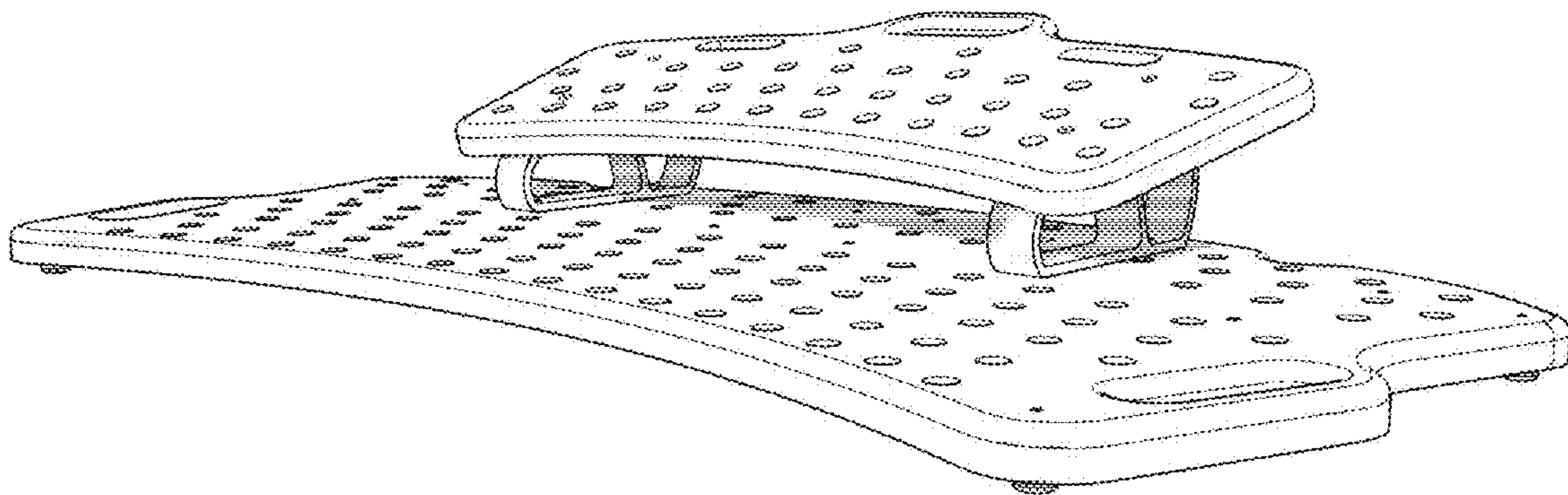

FIG. 7

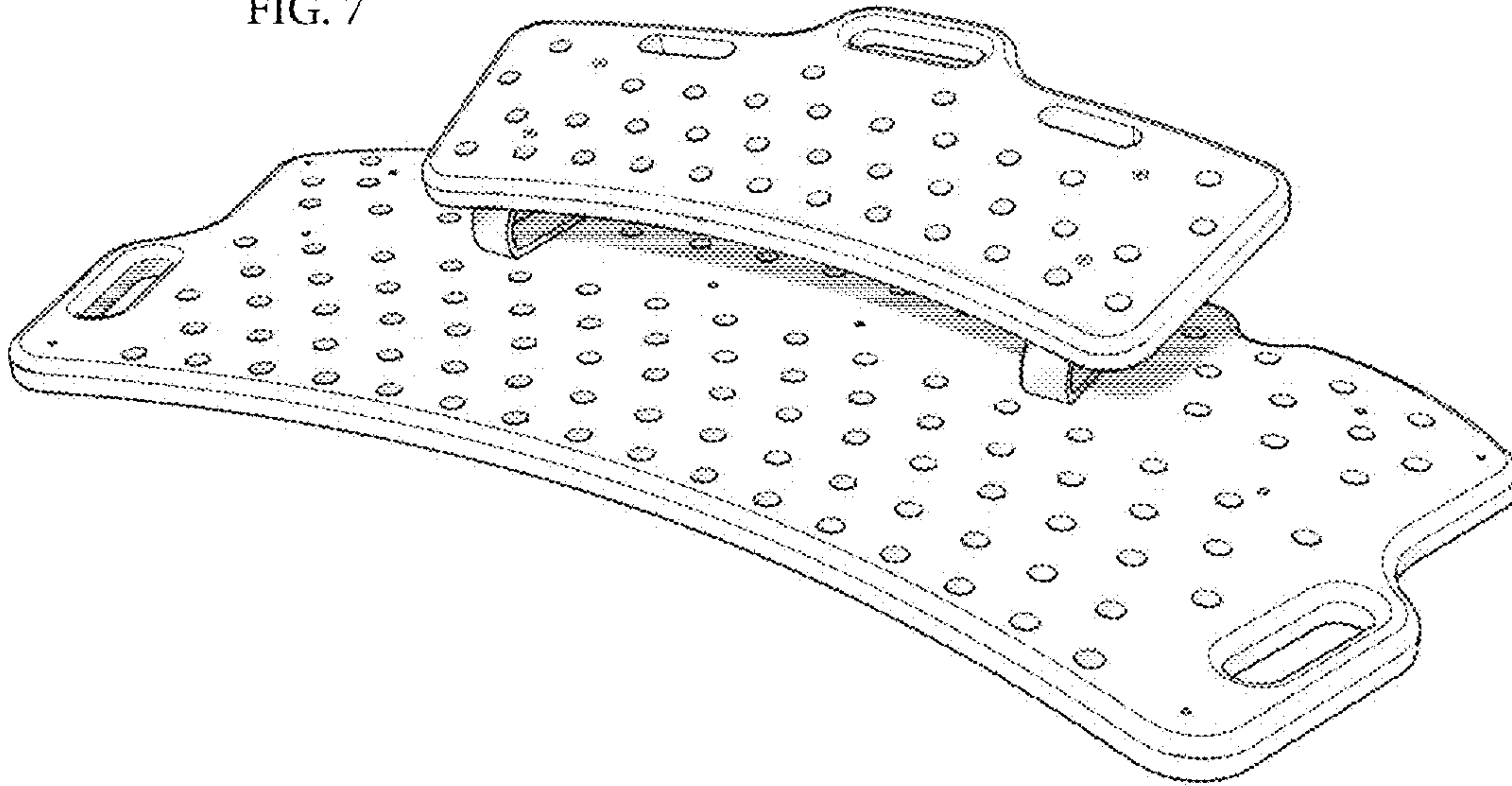

FIG. 8

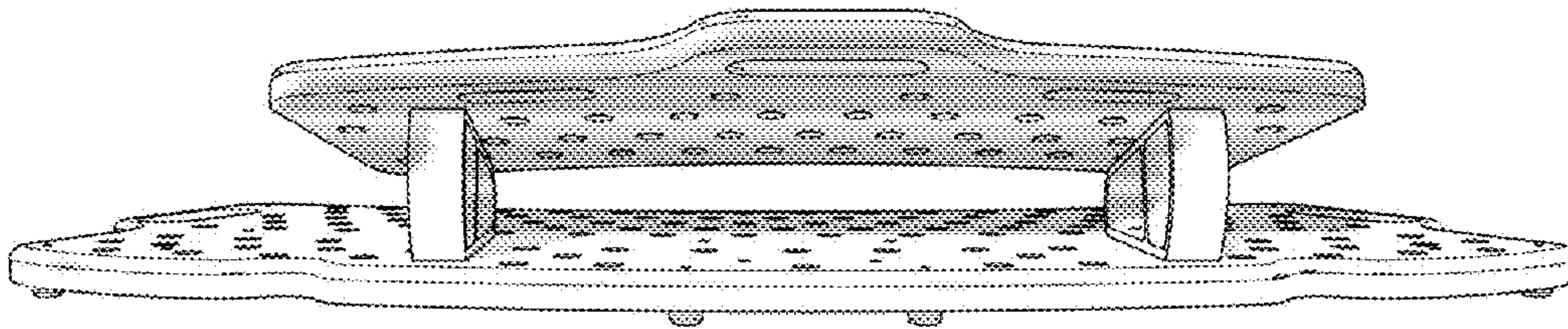

FIG. 9

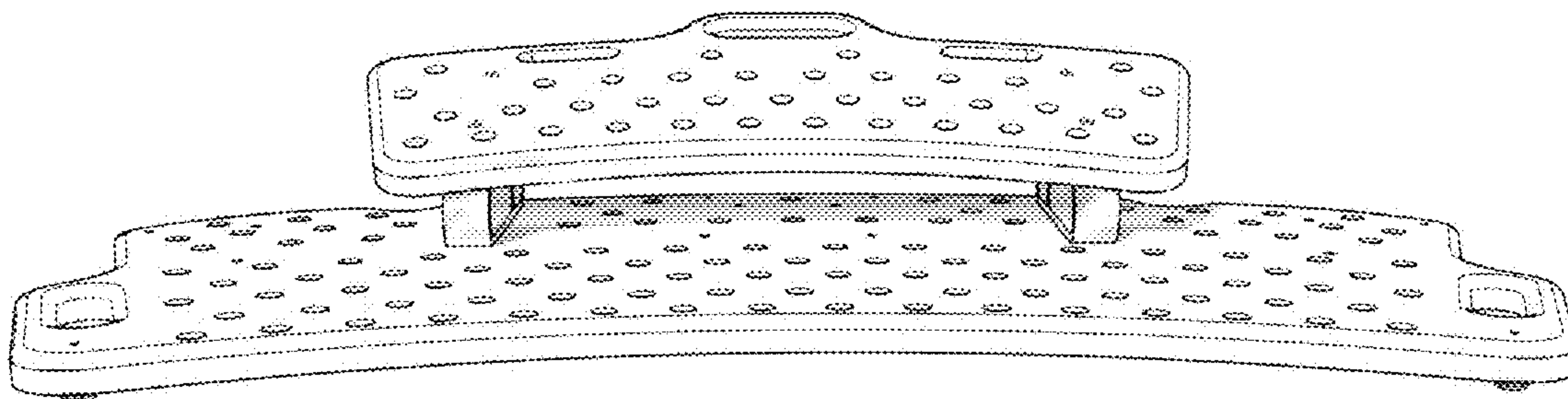

FIG. 10

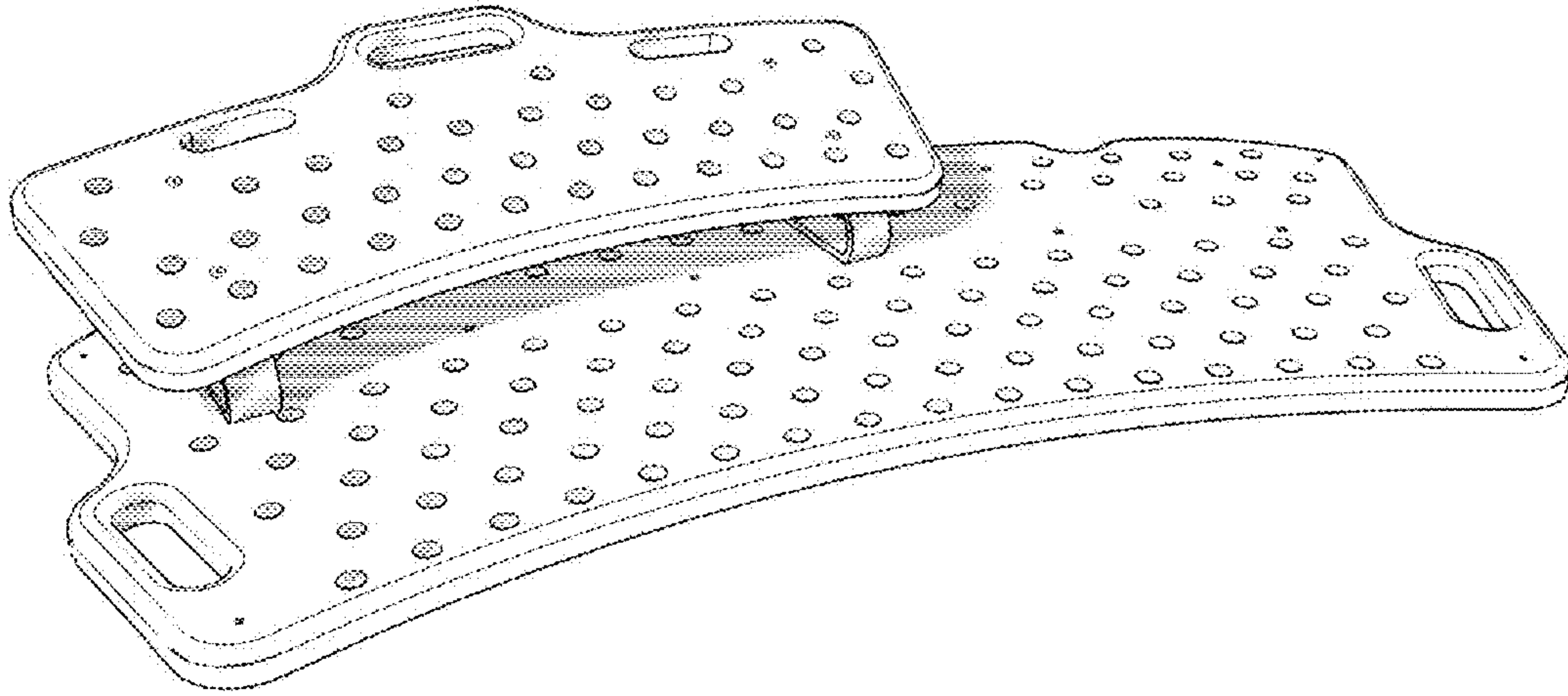

FIG. 11

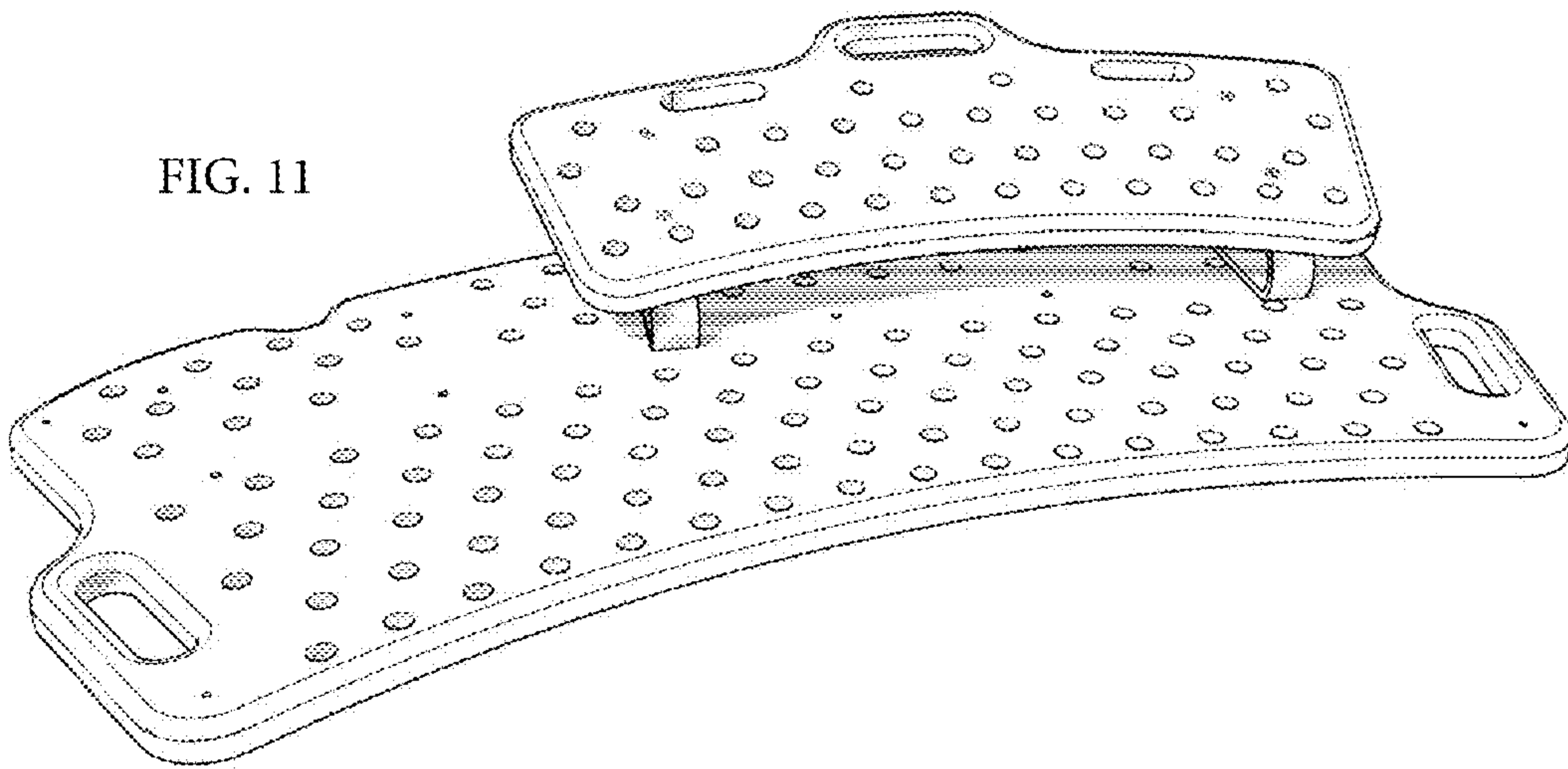

FIG. 12

