



US00D745853S

(12) **United States Design Patent**
Andresen et al.

(10) **Patent No.:** **US D745,853 S**

(45) **Date of Patent:** **** Dec. 22, 2015**

(54) **ELECTRICAL HOUSING**

(71) Applicant: **Phoenix Contact GmbH & Co. KG**,
Blomberg (DE)

(72) Inventors: **Jens Andresen**, Blomberg (DE);
Thorsten Diessel, Hiddenhausen (DE);
Dennis Sprenger, Horn-Bad Meinberg
(DE); **Detlef Nehm**,
Schieder-Schwalenberg (DE)

(73) Assignee: **PHOENIX CONTACT GMBH & CO.**
KG, Blomberg (DE)

(**) Term: **14 Years**

(21) Appl. No.: **29/467,292**

(22) Filed: **Sep. 18, 2013**

(30) **Foreign Application Priority Data**

Mar. 19, 2013 (DE) 40 2013 001 374

(51) **LOC (10) Cl.** **13-99**

(52) **U.S. Cl.**
USPC **D13/184**

(58) **Field of Classification Search**

USPC D13/123, 133, 150, 151, 153, 154, 156,
D13/184, 199; 439/97, 98, 105, 108, 207,
439/208, 304, 310, 325, 338, 344, 345, 347,
439/350, 367, 370, 372, 374, 527, 532, 533,
439/620.15, 894, 901, 903; D10/81;
361/158.1

CPC H01R 13/516

See application file for complete search history.

(56) **References Cited**

U.S. PATENT DOCUMENTS

4,404,615	A *	9/1983	Dep	361/212
6,213,795	B1 *	4/2001	Drescher et al.	439/157
7,297,014	B1 *	11/2007	Stowers et al.	439/372
D719,514	S *	12/2014	Andresen et al.	D13/151
8,979,568	B2 *	3/2015	Herbrechtsmeier et al.	..	439/346
2009/0258530	A1 *	10/2009	Nehm	439/372

* cited by examiner

Primary Examiner — Ian Simmons

Assistant Examiner — Harold Blackwell, II

(74) *Attorney, Agent, or Firm* — Leydig, Voit & Mayer, Ltd.

(57) **CLAIM**

The ornamental design for an electrical housing, as shown and described.

DESCRIPTION

FIG. 1 is a top right front perspective view of the electrical housing showing our new design;
FIG. 2 is a bottom plan view thereof;
FIG. 3 is a rear elevational view thereof, the front elevational view being the mirror image thereof;
FIG. 4 is a left side elevational view thereof, the right side elevational view being the mirror image thereof; and,
FIG. 5 is a top plan view thereof.

The broken lines in the drawings illustrate portions of an electrical housing which form no part of the claimed design.

1 Claim, 5 Drawing Sheets

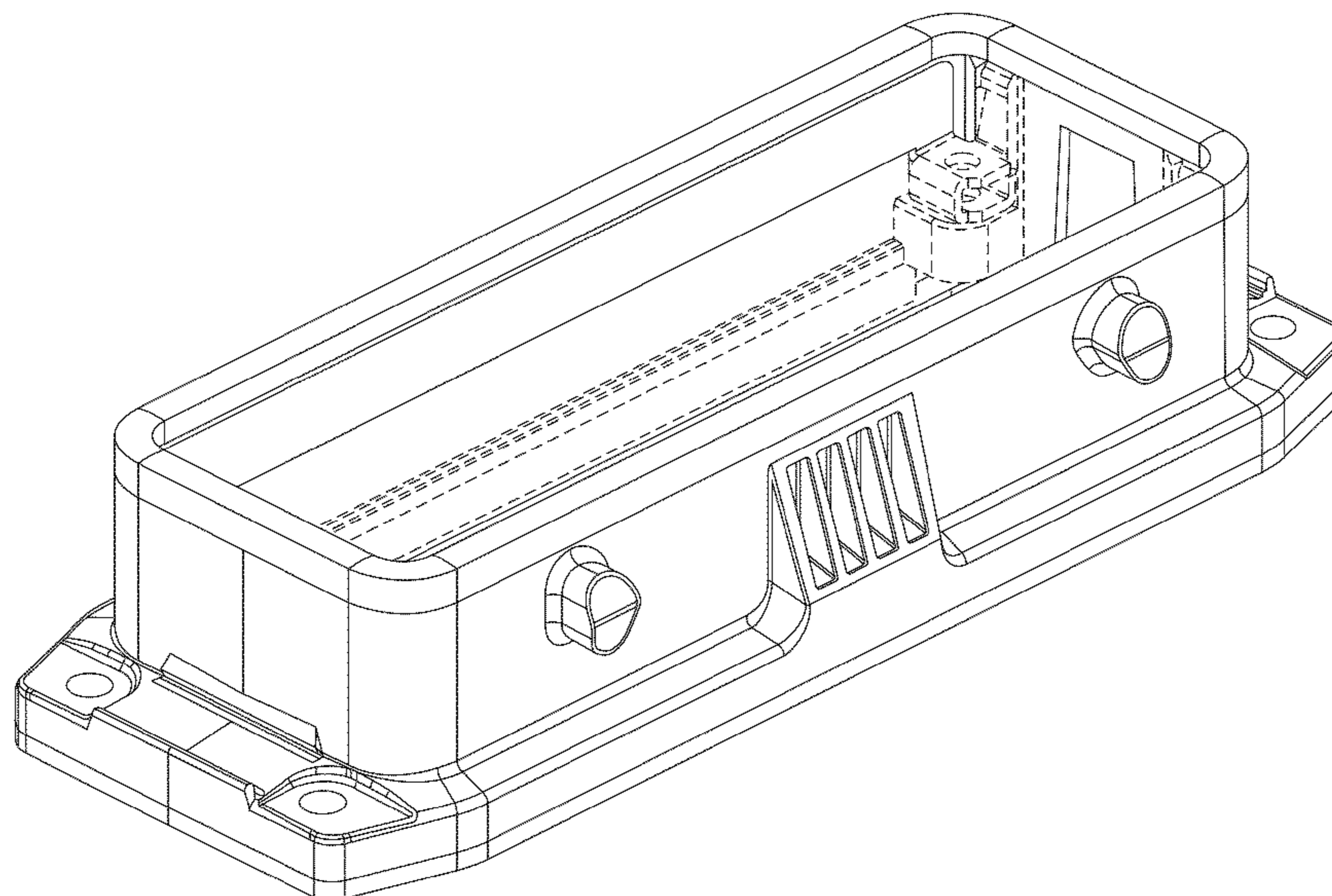

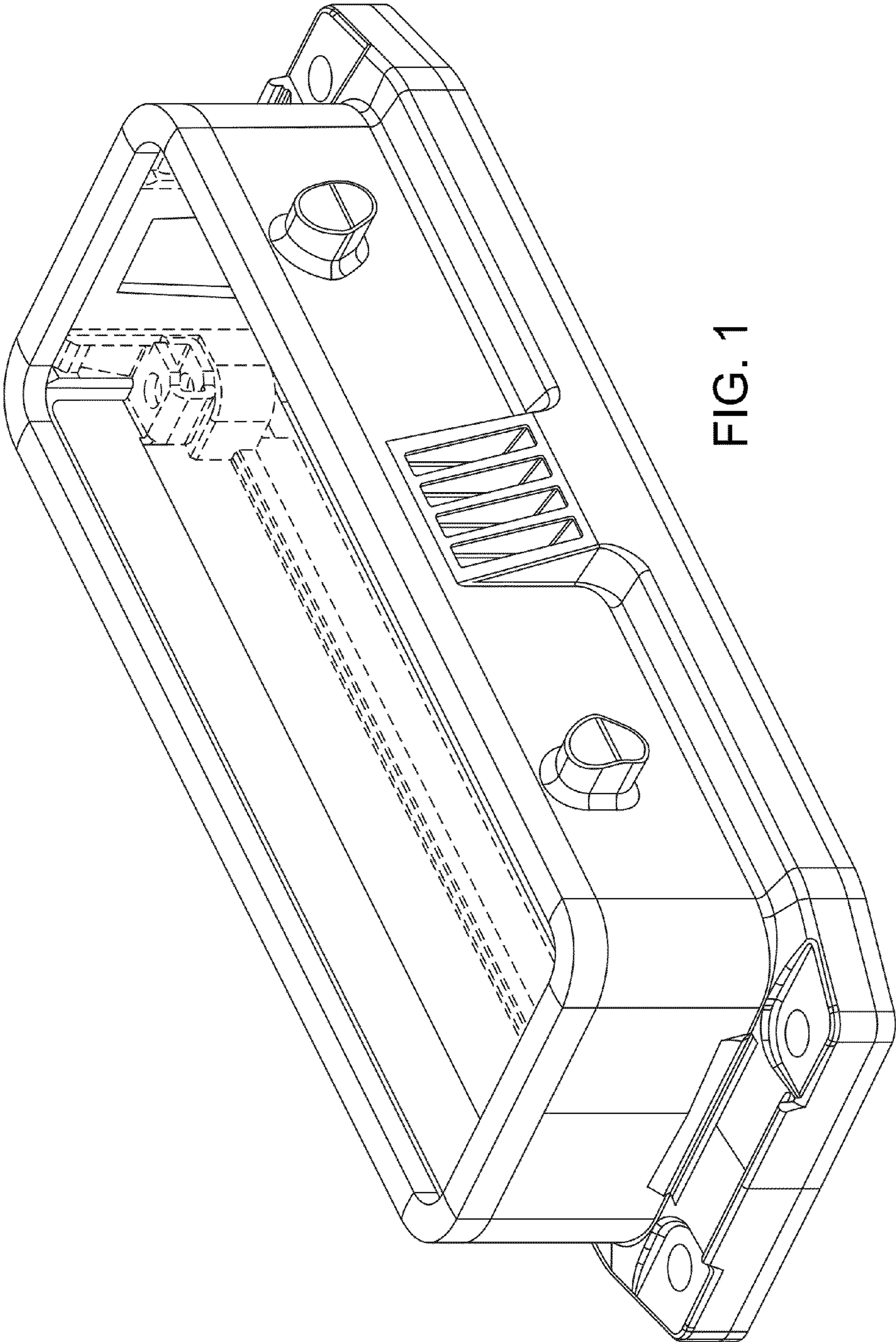

FIG. 1

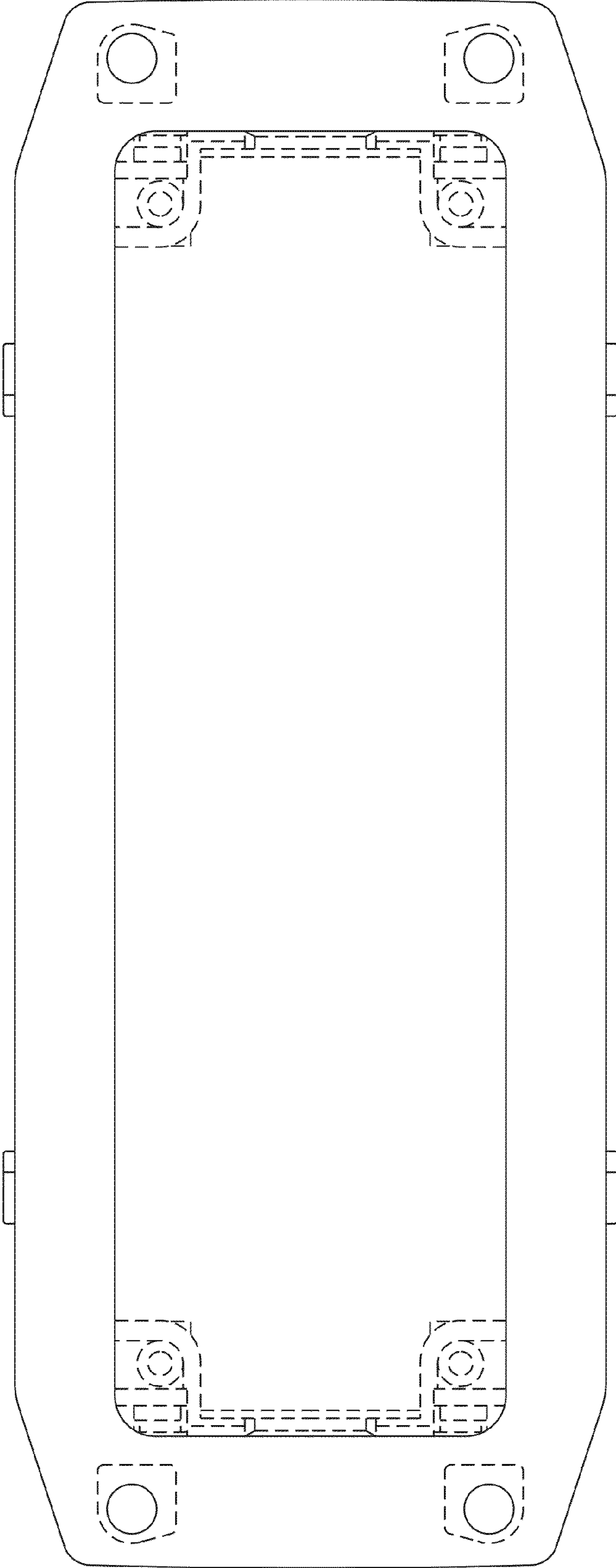

FIG. 2

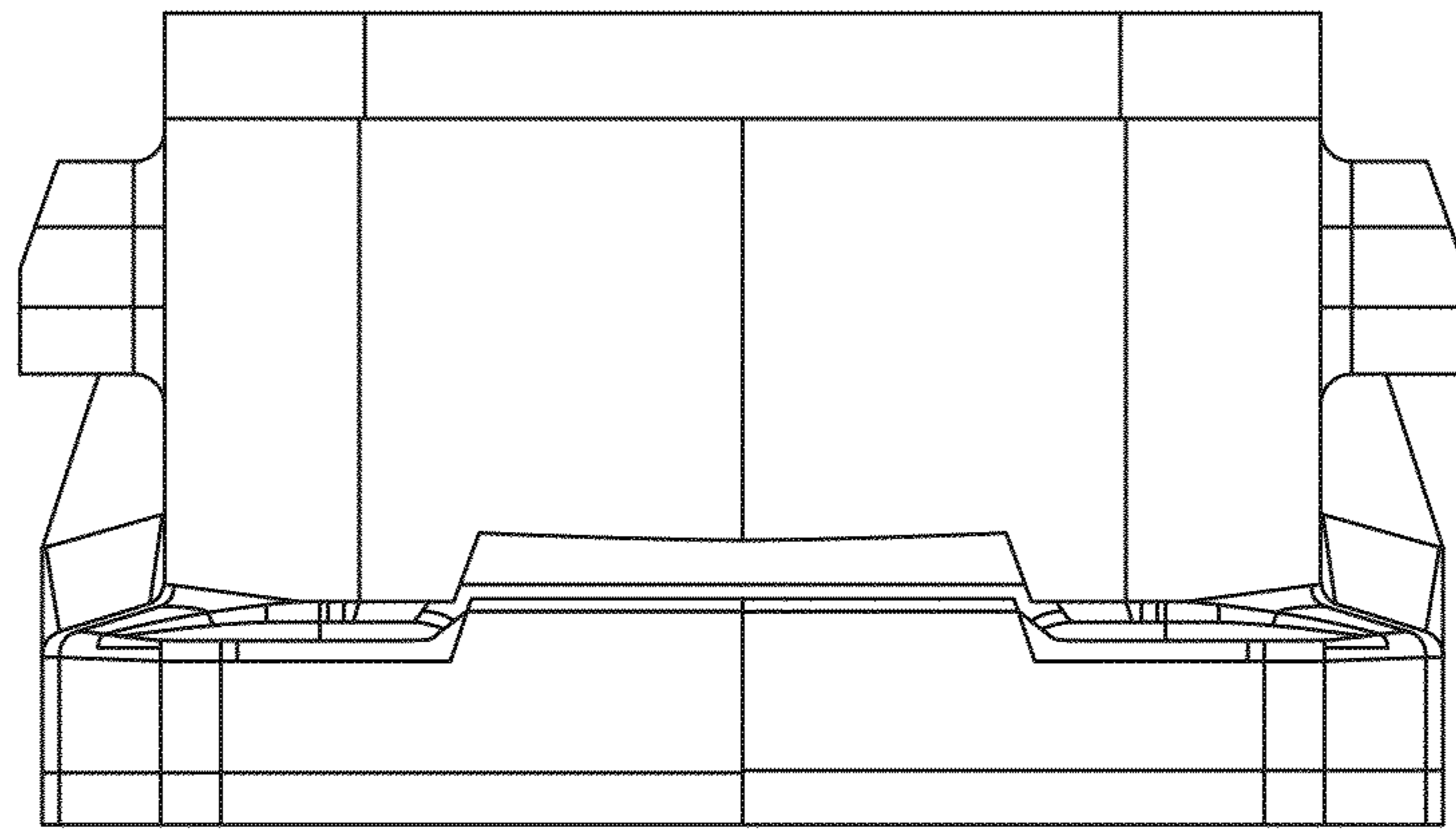

FIG. 3

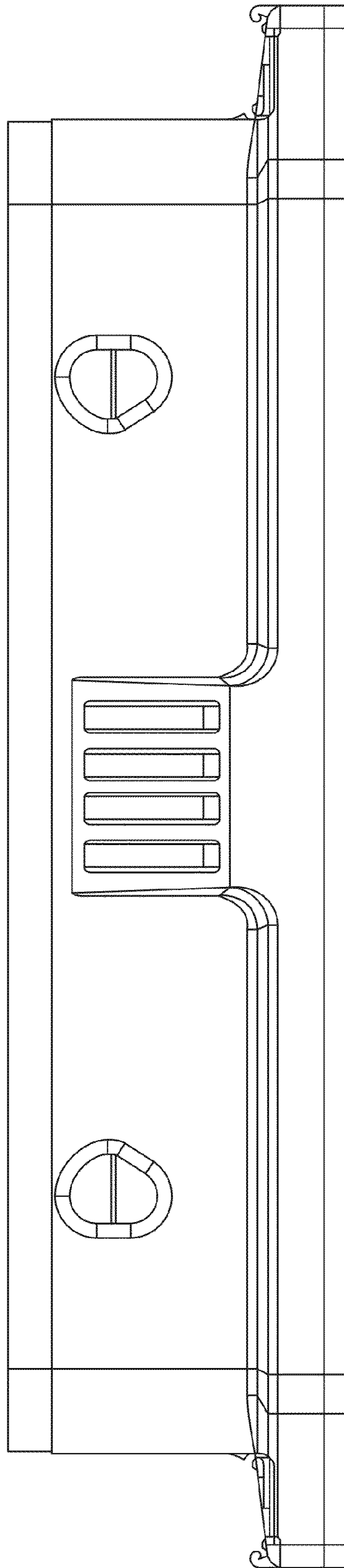

FIG. 4

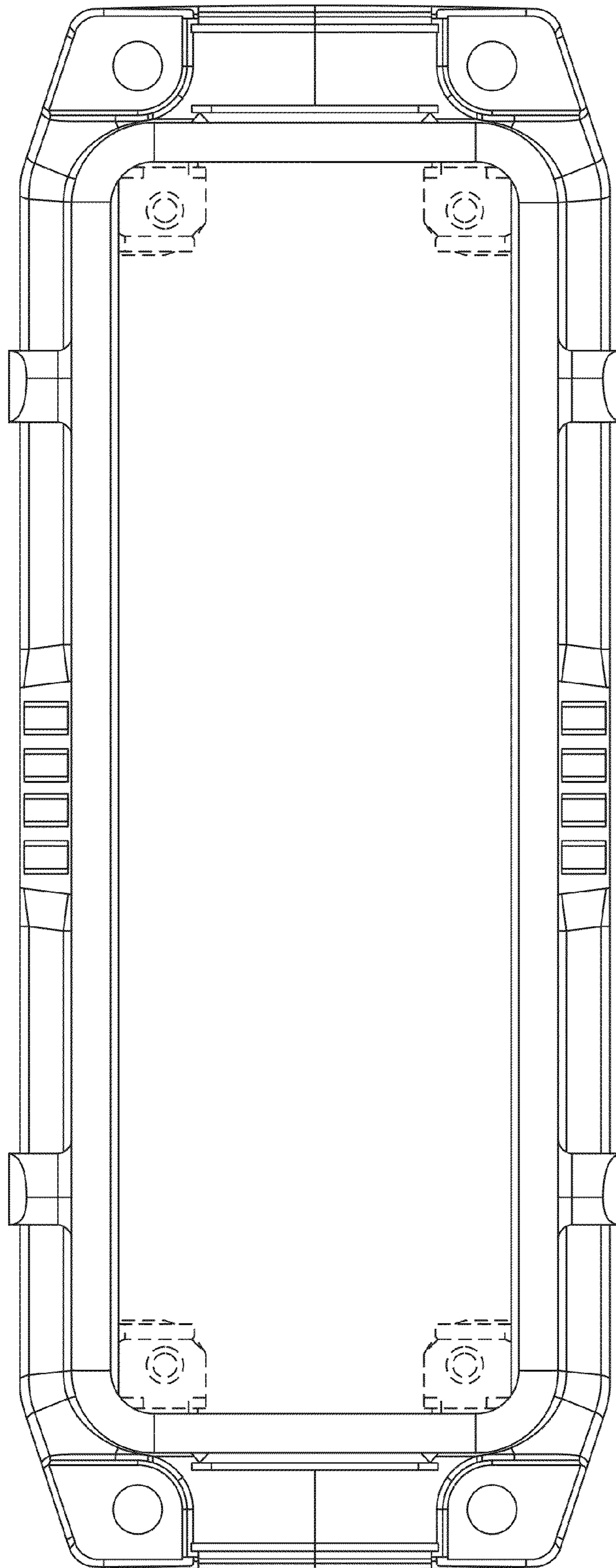

FIG. 5