



US00D745788S

(12) **United States Design Patent**  
**Schreiter**

(10) **Patent No.:** **US D745,788 S**

(45) **Date of Patent:** **\*\* Dec. 22, 2015**

(54) **WORK SURFACE**

(71) Applicant: **Johannes Schreiter**, Offenbach (DE)

(72) Inventor: **Johannes Schreiter**, Offenbach (DE)

(\*\*) Term: **14 Years**

(21) Appl. No.: **29/507,938**

(22) Filed: **Oct. 31, 2014**

(30) **Foreign Application Priority Data**

Oct. 7, 2014	(EM)	002552141-0001
Oct. 7, 2014	(EM)	002552141-0002
Oct. 7, 2014	(EM)	002552141-0003
Oct. 7, 2014	(EM)	002552141-0004
Oct. 7, 2014	(EM)	002552141-0005
Oct. 7, 2014	(EM)	002552141-0006
Oct. 7, 2014	(EM)	002552141-0007
Oct. 7, 2014	(EM)	002552141-0008

(51) **LOC (10) Cl.** ..... **06-06**

(52) **U.S. Cl.**  
USPC ..... **D6/406.3**

(58) **Field of Classification Search**  
USPC ..... D6/406.3, 406.5, 406.6, 419, 339, 511;  
D19/92; D7/550.1, 554.3, 555, 553.2  
CPC ..... A47B 17/00; A47B 23/00; A47B 23/001;  
A47B 23/002  
See application file for complete search history.

(56) **References Cited**

**U.S. PATENT DOCUMENTS**

1,708,424	A	4/1929	McLeskey	
3,317,260	A	5/1967	Levit et al.	
3,701,576	A	10/1972	Moen	
D253,438	S *	11/1979	Markley	D3/274
4,363,587	A	12/1982	Rooklyn	
D315,456	S *	3/1991	Couch et al.	D6/406.4
D327,200	S *	6/1992	Szablak et al.	D7/554.3
D328,985	S *	9/1992	Sheldon	D6/406.4
D359,399	S *	6/1995	Rath	D19/91
D364,503	S *	11/1995	Johnson	D3/273
5,692,815	A *	12/1997	Murphy	312/283

D418,327	S *	1/2000	Sullins et al.	D6/406.3
D443,999	S *	6/2001	Cable	D6/406.4
6,311,944	B1 *	11/2001	McKsymick et al.	248/461
D484,664	S *	12/2003	Arceta	D34/27
D499,574	S *	12/2004	Spicer	D6/406.3
D514,057	S *	1/2006	Borunda et al.	D12/426.1
D517,833	S *	3/2006	Jennings	D6/406.5
D616,700	S *	6/2010	Pourounidis et al.	D7/388
D630,452	S *	1/2011	Robbins et al.	D6/406.3
D656,500	S *	3/2012	Maruyama et al.	D14/447
D679,921	S *	4/2013	Kiechler	D6/406.5
8,667,903	B1 *	3/2014	Goltry	108/4
D703,002	S *	4/2014	Tiemann	D7/600.1
D708,909	S *	7/2014	Tiemann	D7/600.1
D713,692	S *	9/2014	Tsai	D7/600.1
8,851,439	B2 *	10/2014	Phifer et al.	248/460
D720,152	S *	12/2014	Chauss et al.	D6/406.3
2015/0221187	A1 *	8/2015	Cho et al.	235/7 R

**FOREIGN PATENT DOCUMENTS**

DE	2856168	A1	7/1980
JP	2000037251	A	2/2000
WO	2013160086	A1	10/2013

**OTHER PUBLICATIONS**

The International Search Report from related International Application No. PCT/EP2013/057217, mailing date Jul. 4, 2014, 2 pages.  
The International Preliminary Report on Patentability from related International Application No. PCT/EP2013/057217, 5 pages.

\* cited by examiner

*Primary Examiner* — Kelley Donnelly

(74) *Attorney, Agent, or Firm* — Lucas & Mercanti, LLP

(57) **CLAIM**

The ornamental design for a work surface, as shown and described.

**DESCRIPTION**

FIG. 1 is a perspective view of a first embodiment of the work surface from the right side showing retractable holders in a retracted position. The left side is a mirror image of the right side;

FIG. 2 is a perspective view of the first embodiment of the work surface from the right side showing all retractable hold-

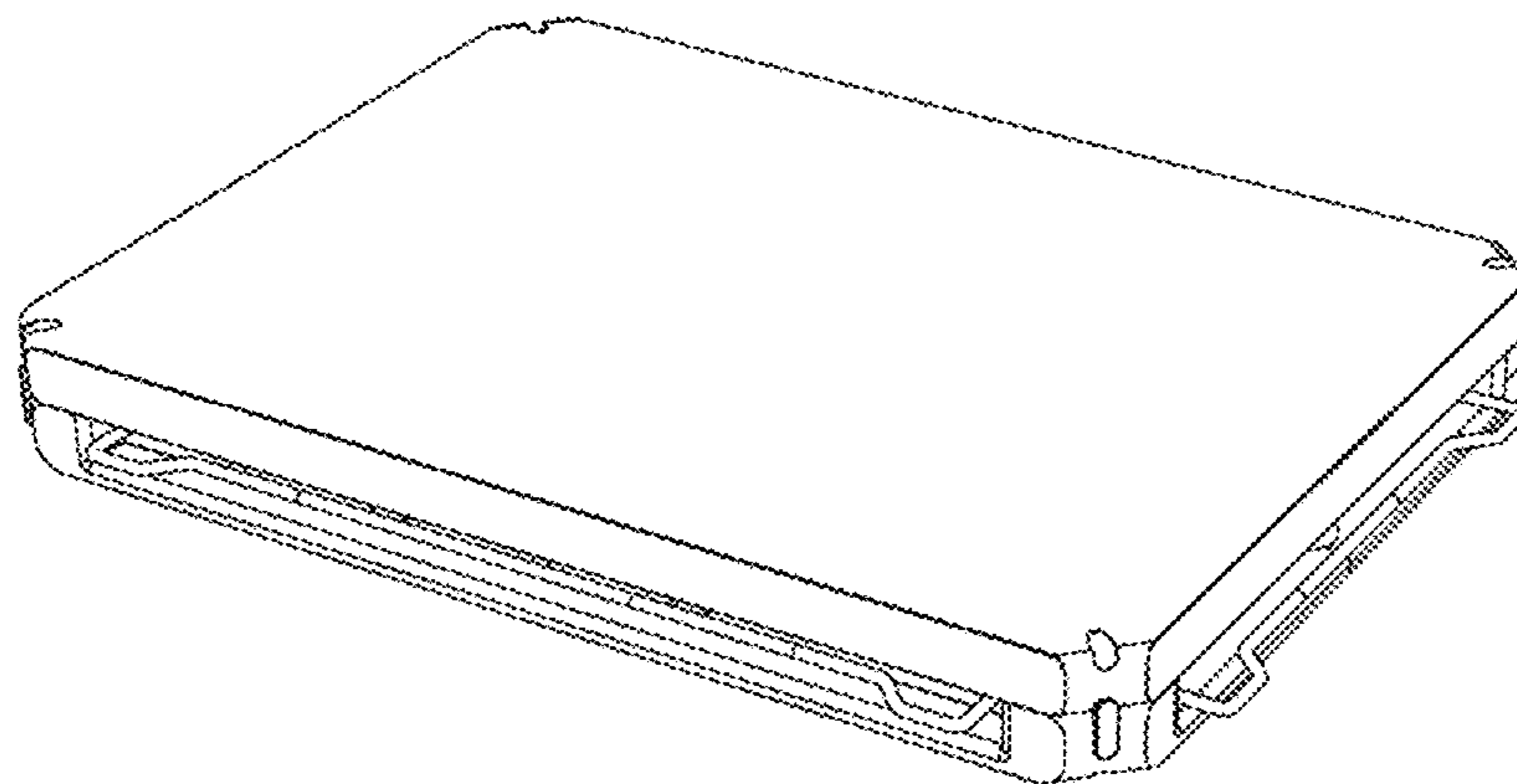

ers and all retractable dividers in an extended position. The left side is a mirror image of the right side;

FIG. 3 is a perspective view of the first embodiment of the work surface from the right side, showing all retractable holders and dividers in an extended position except for one central divider in a retracted position. The left side is a mirror image of the right side;

FIG. 4 is a perspective view of the first embodiment of the work surface from the right side showing the central retractable holder in an extended position and the side holders in a retracted position. The left side is a mirror image of the right side;

FIG. 5 is fifth perspective view of the first embodiment of the work surface from the right side showing the central retractable holder in an extended position and the side holders in a retracted position. One central divider is in a retracted position and the other central divider is in a retracted position. The left side is a mirror image of the right side;

FIG. 6 is a perspective view of the first embodiment of the work surface from the right side showing the central and left side retractable holders in a retracted position and the right side holder in an extended position;

FIG. 7 is a perspective view of the first embodiment of the work surface from the right side, showing the central and left side retractable holders in a retracted position and the right side holder in an extended position with the divider in a retracted position;

FIG. 8 is a perspective view of a second embodiment of the work surface from the right side, showing the central and right side retractable holders in an extended position and the left side holder in a retracted position;

FIG. 9 is a perspective view of the second embodiment of the work surface from the right side, the left side is a mirror image of the right side;

FIG. 10 is a perspective view of the second embodiment of the work surface from the right side, showing the central and right side retractable holders in an extended position with one central divider in a retracted position, and the left side holder in a retracted position;

FIG. 11 is a second perspective view of the second embodiment of the work surface from the right side showing the central retractable holder in an extended position and the side holders in a retracted position. The left side is a mirror image of the right side;

FIG. 12 is a perspective view of the second embodiment of the work surface from the right side showing the central retractable holder in an extended position and the side holders in a retracted position. One central divider is in a retracted position and the other central divider is in a retracted position. The left side is a mirror image of the right side;

FIG. 13 is a perspective view of the second embodiment of the work surface from the right side showing the central and left side retractable holders in a retracted position and the right side holder in an extended position; and,

FIG. 14 is a perspective view of the second embodiment of the work surface from the right side, showing the central and left side retractable holders in a retracted position and the right side holder in an extended position with the divider in retracted position.

The broken lines are for the purpose of illustrating the environment of the article only and form no part of the claimed design.

**1 Claim, 7 Drawing Sheets**

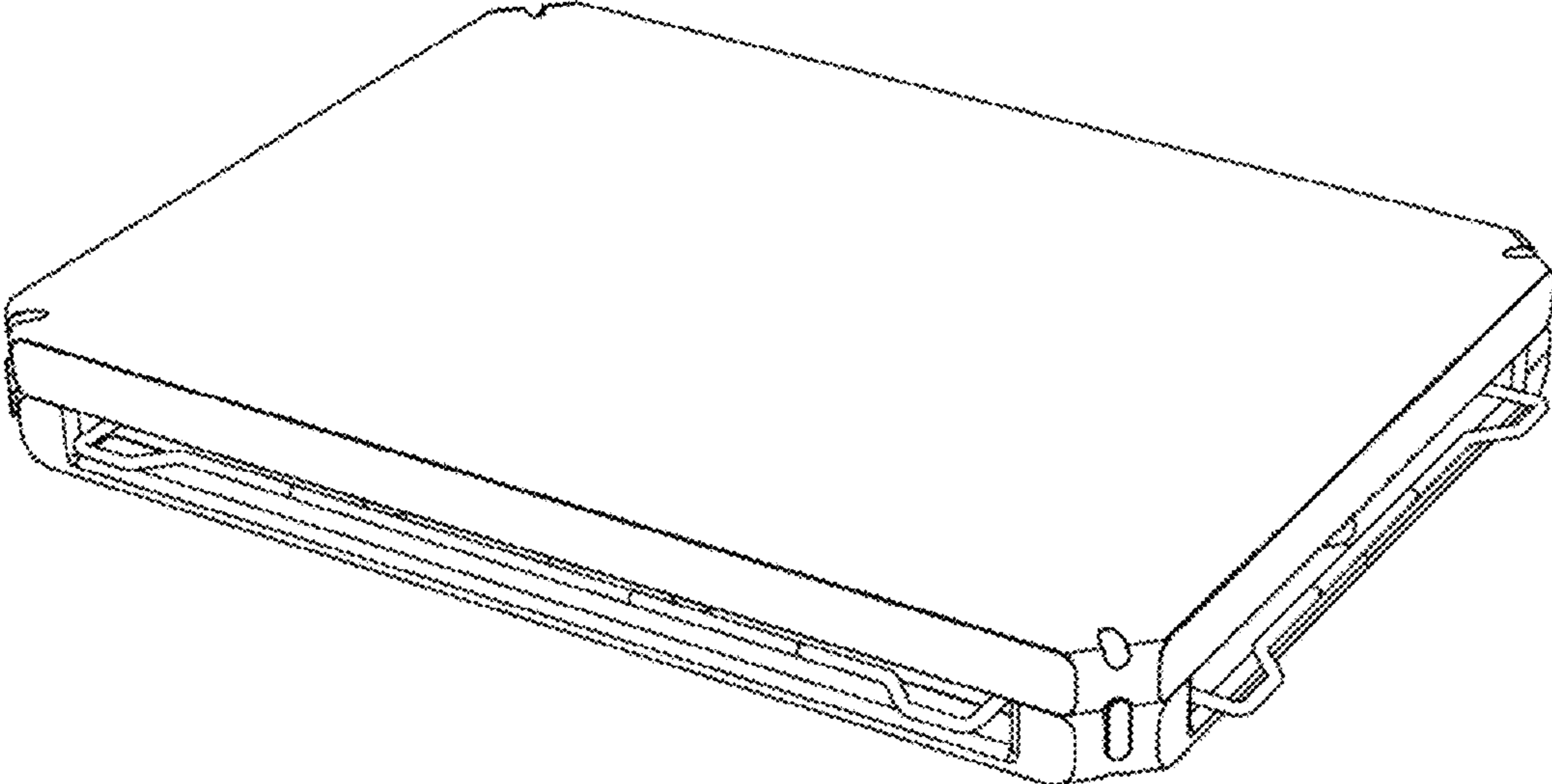

FIG. 1

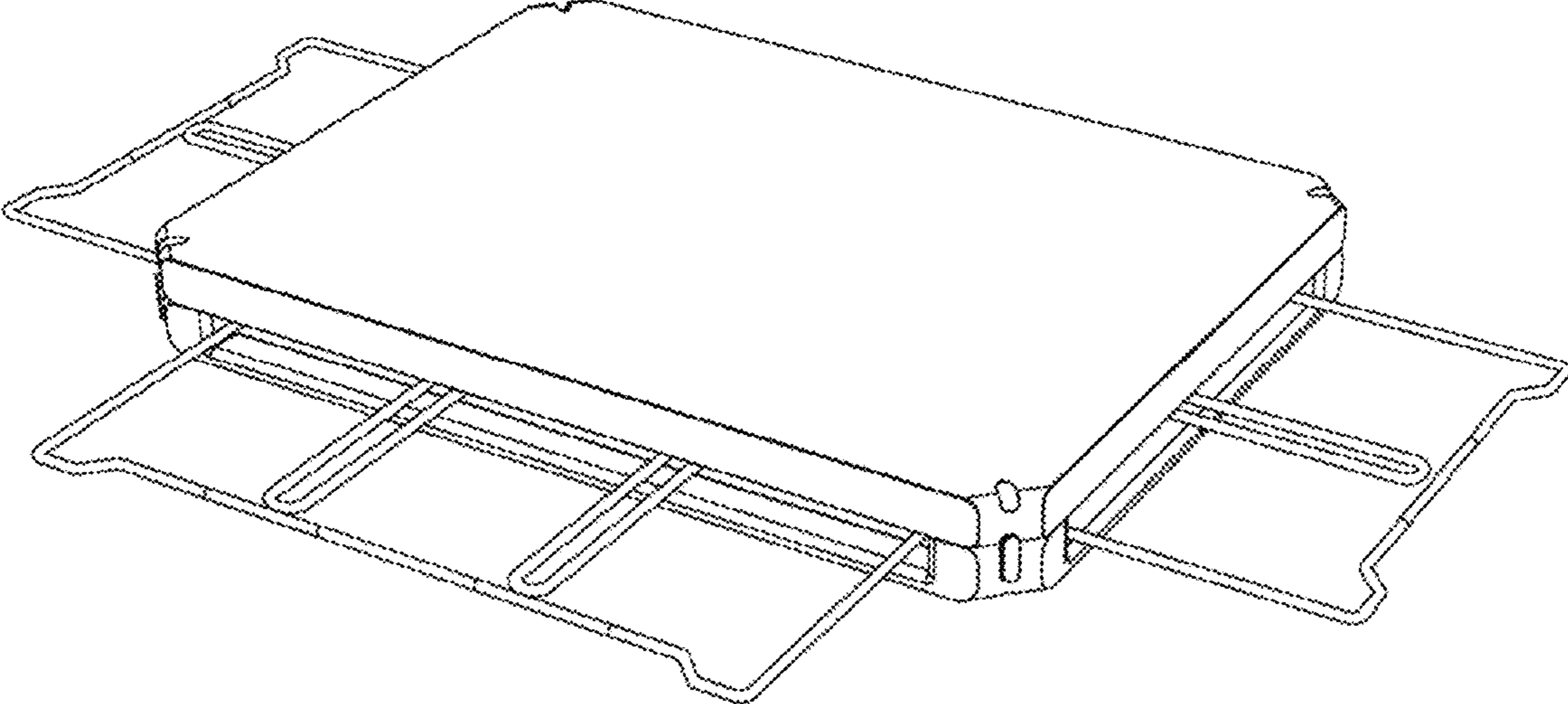

FIG. 2

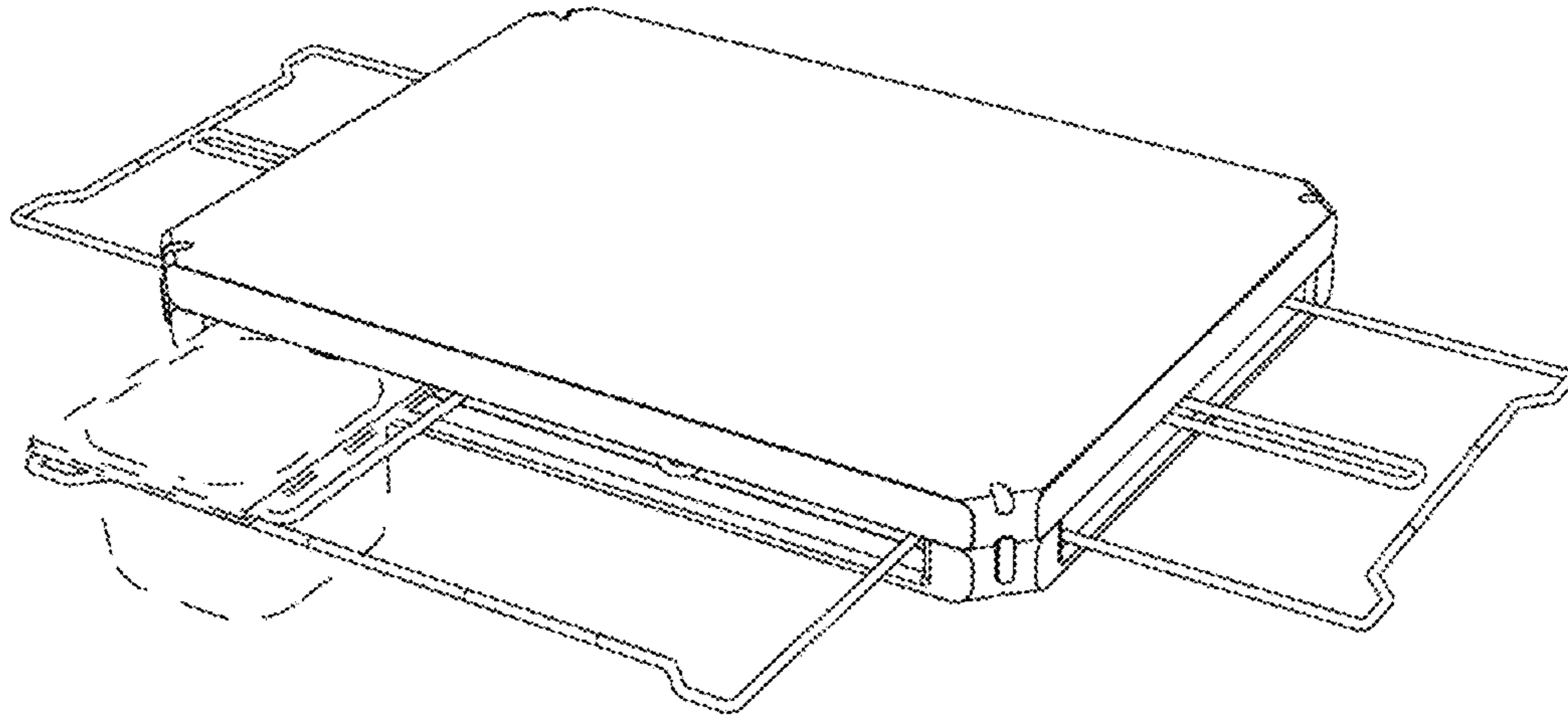

FIG. 3

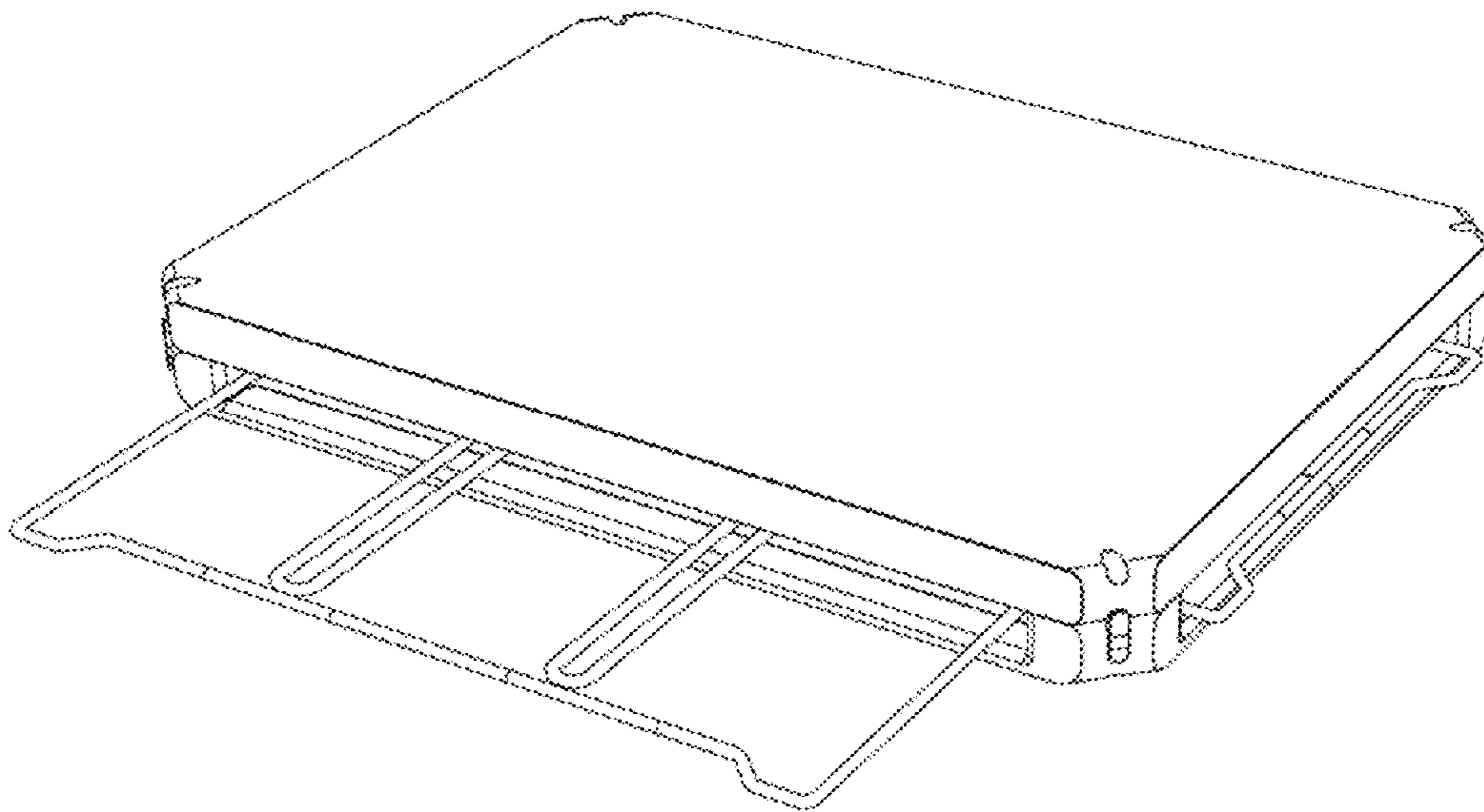

FIG. 4

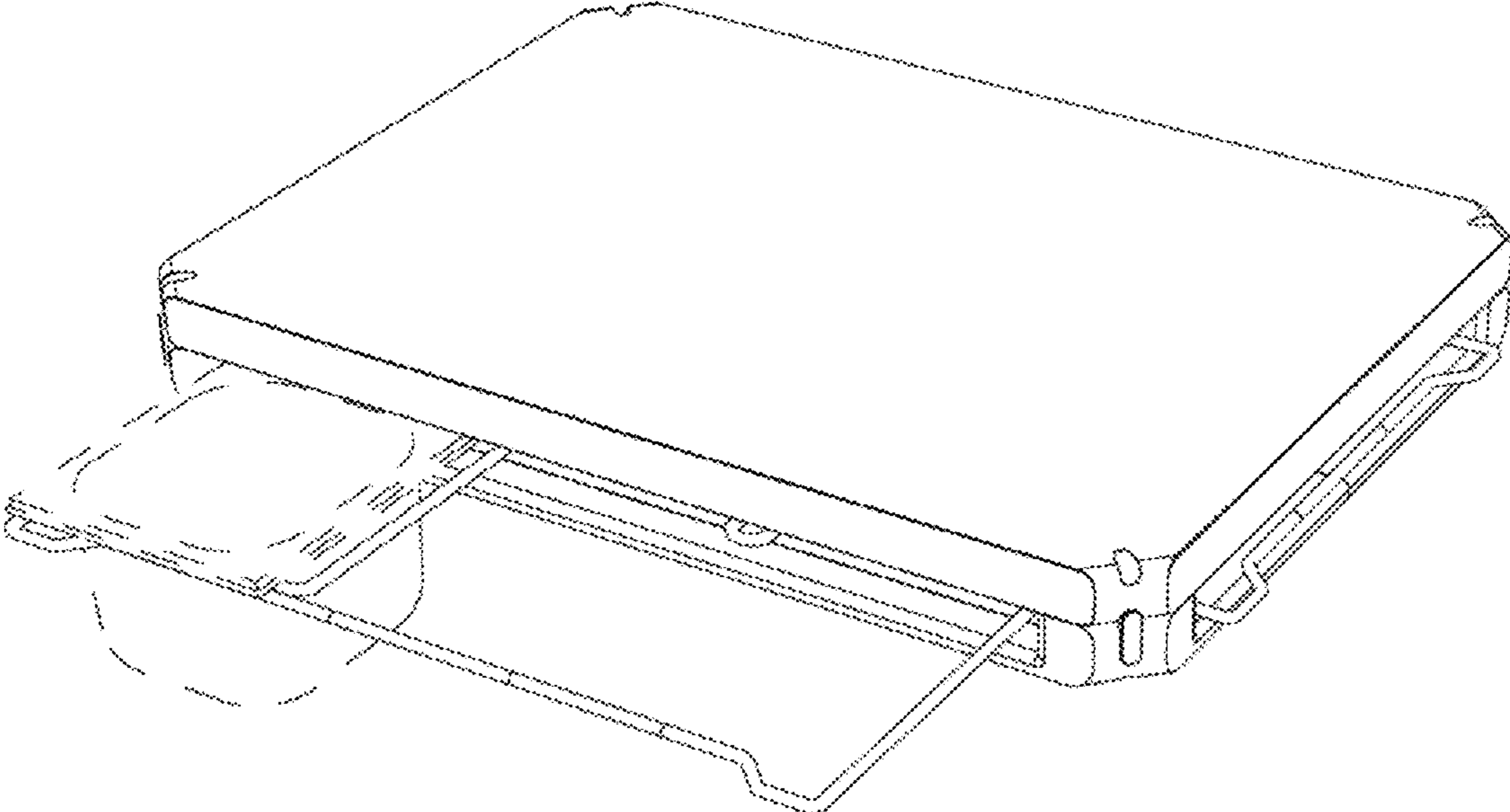

FIG. 5

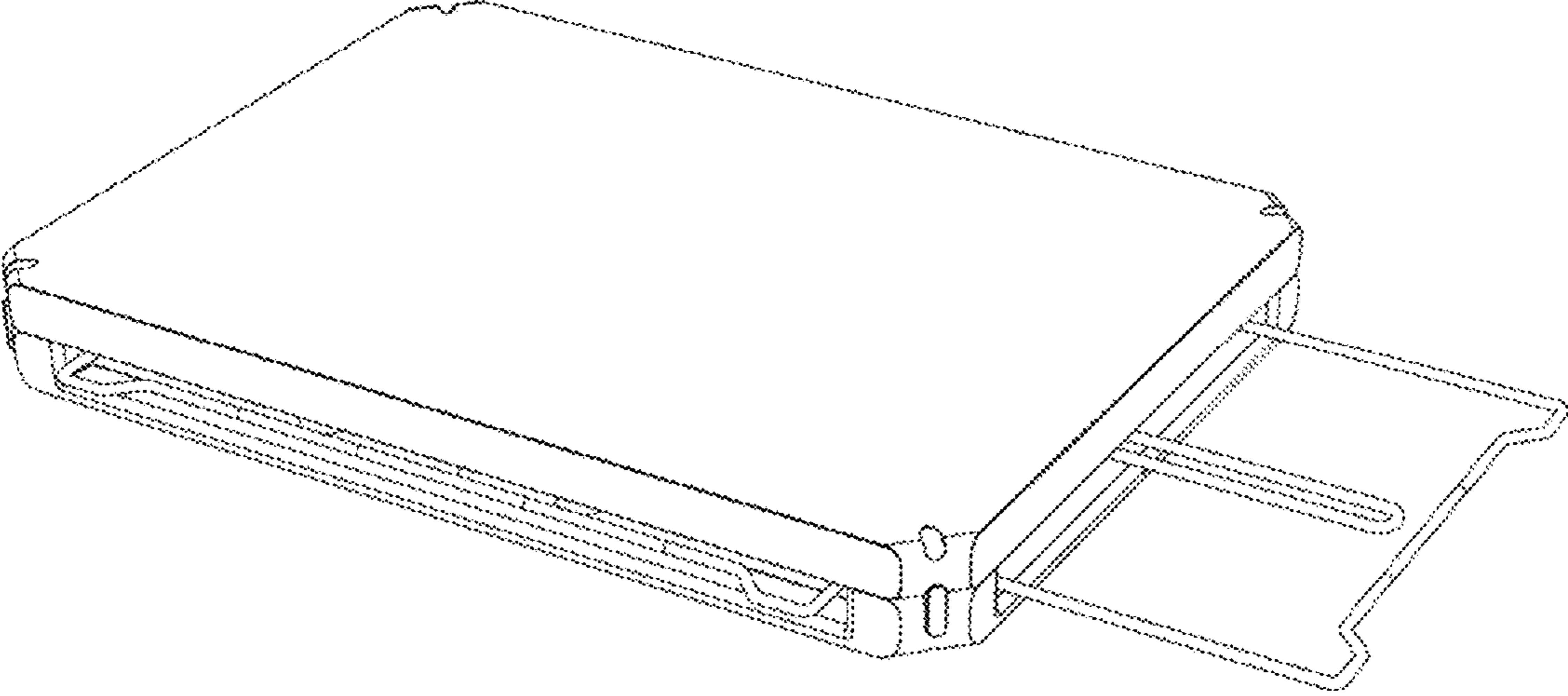

FIG. 6

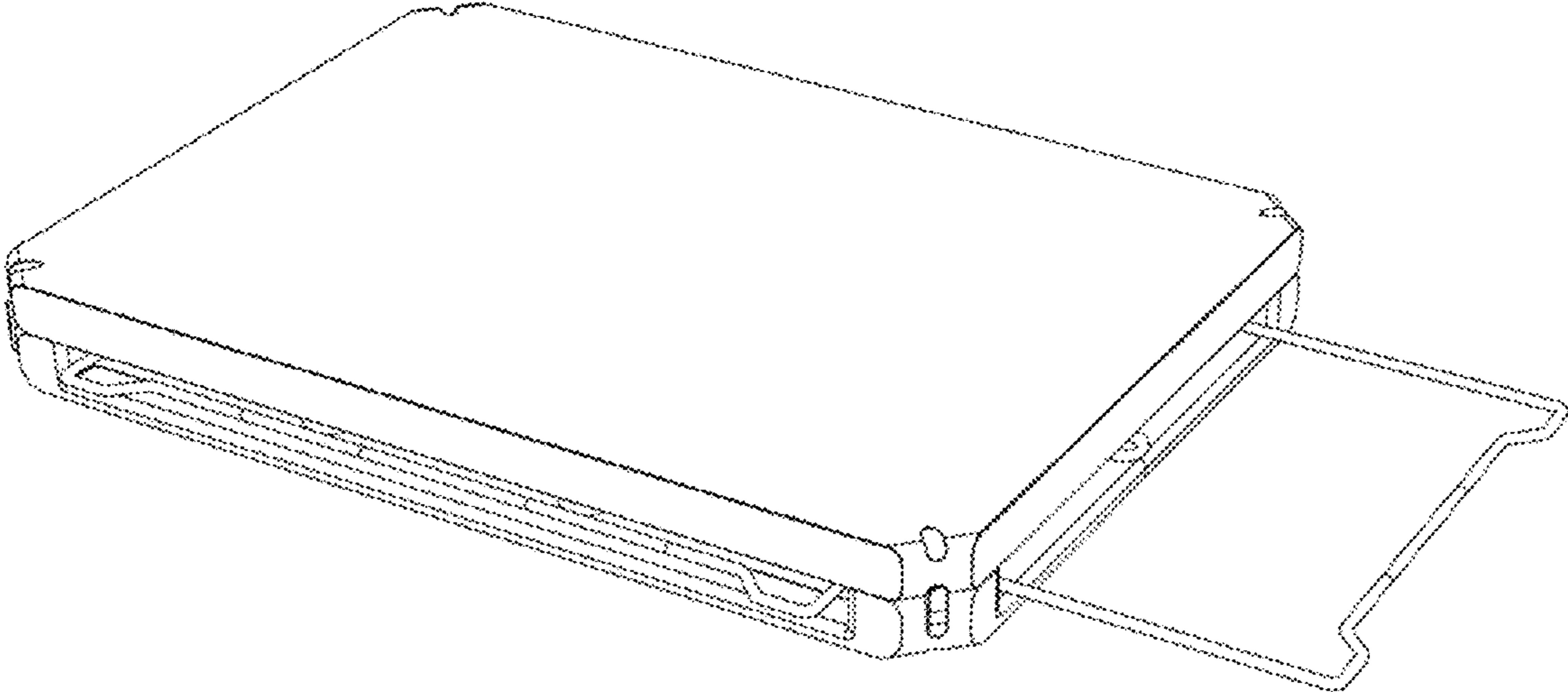

FIG. 7

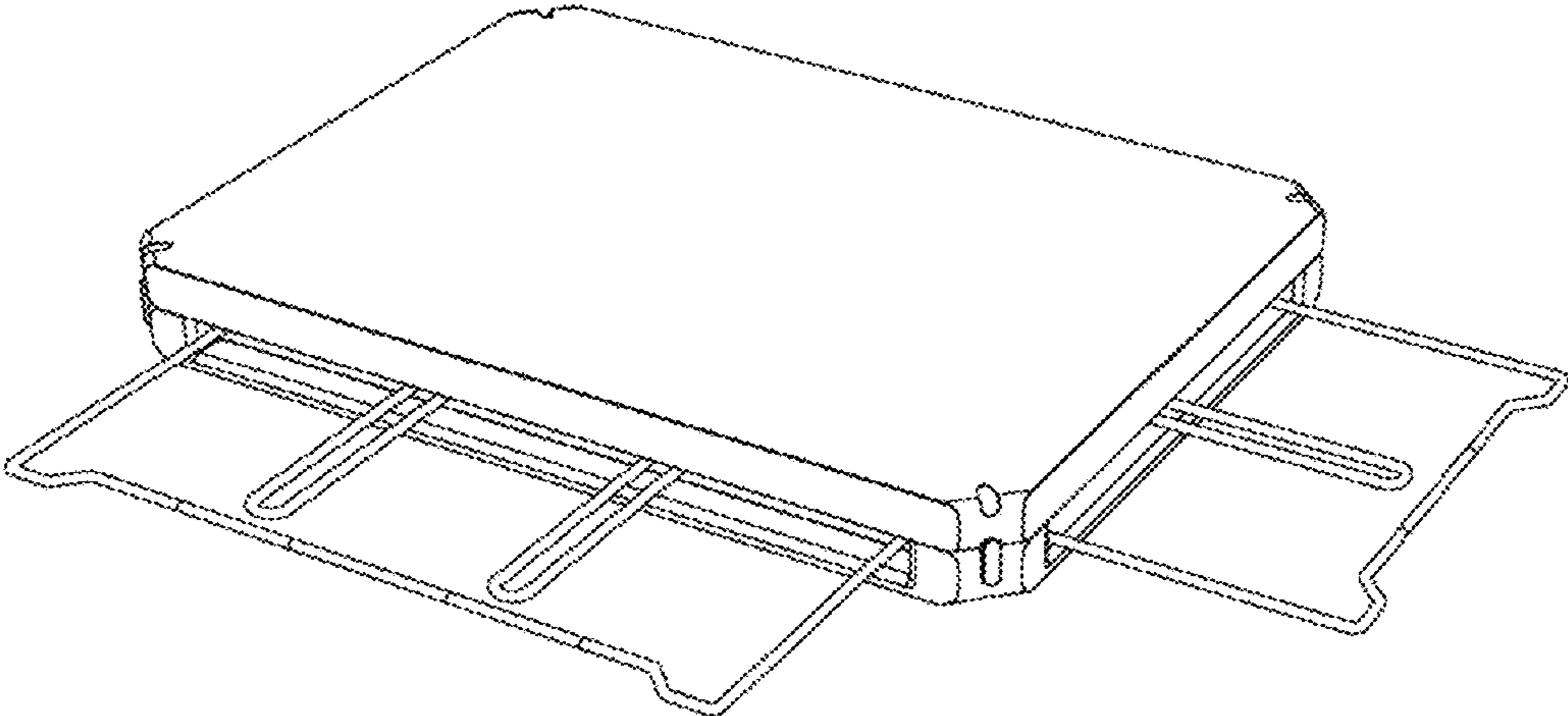

FIG. 8

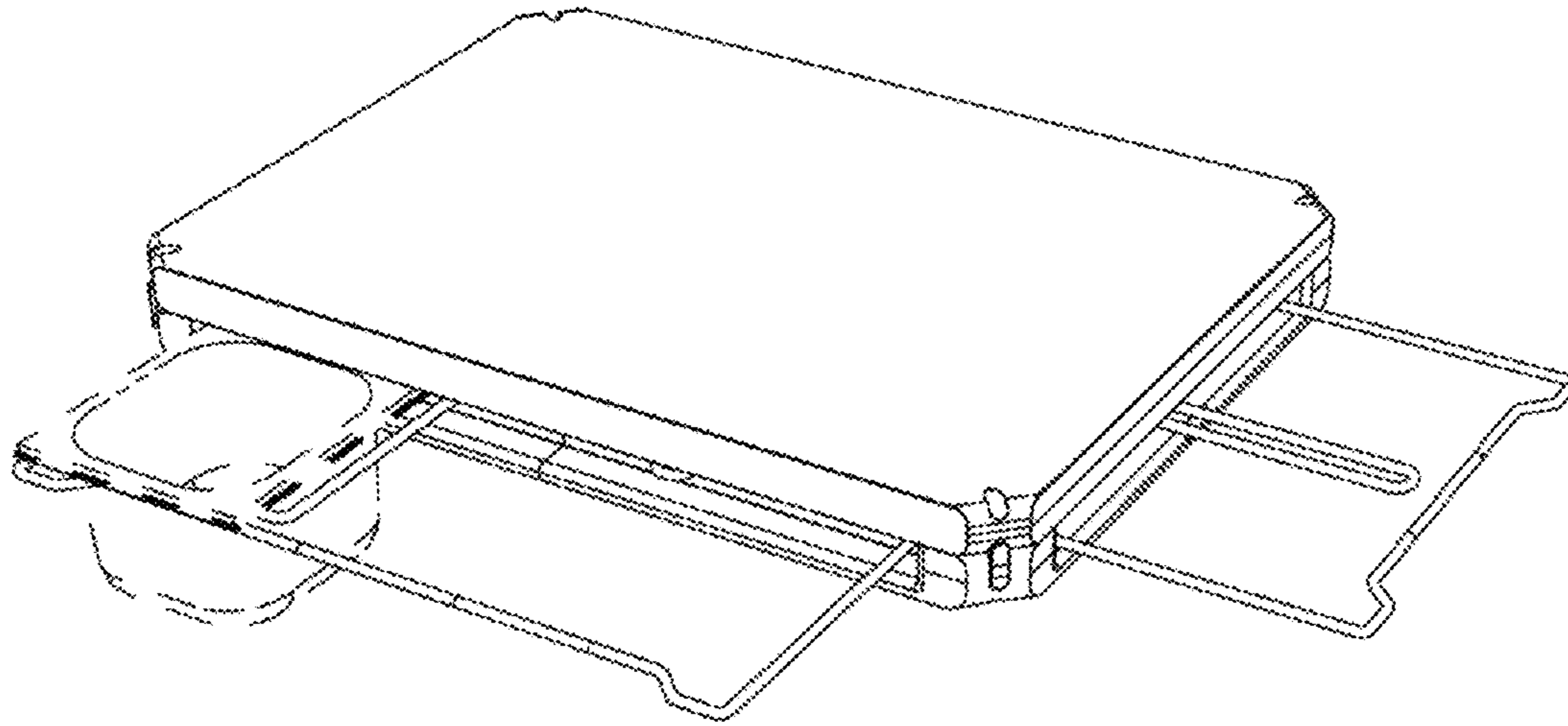

FIG. 9

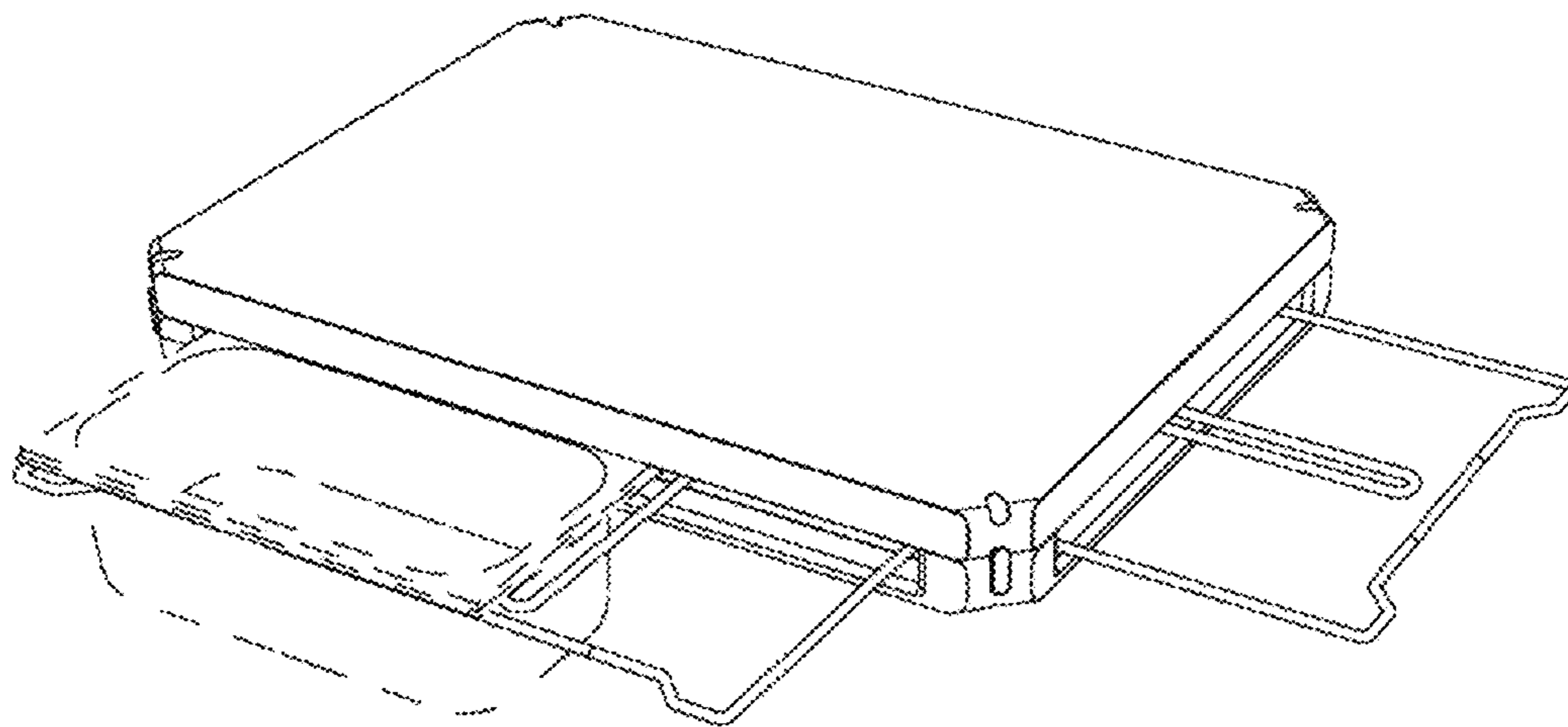

FIG. 10

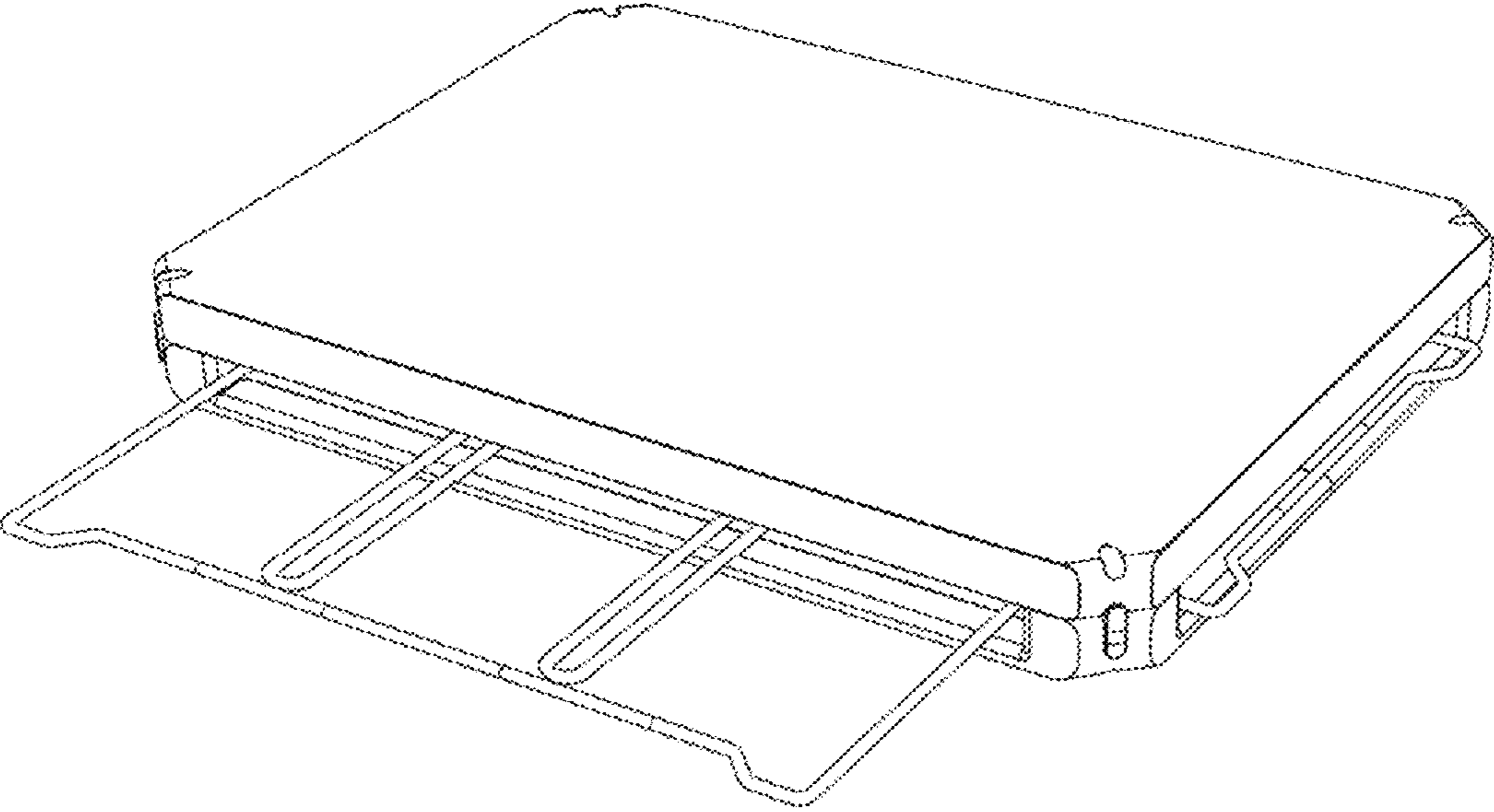

FIG. 11

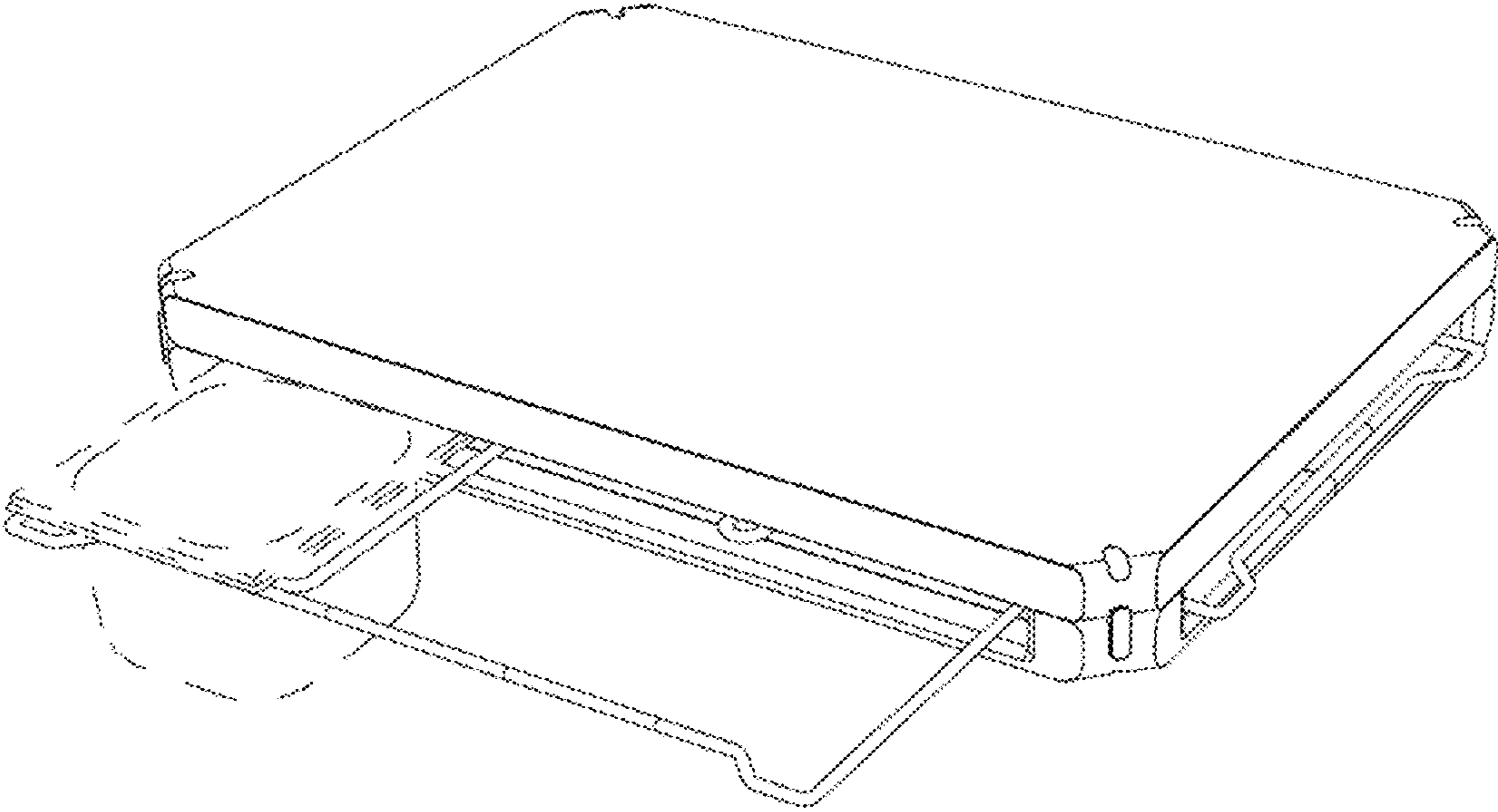

FIG. 12



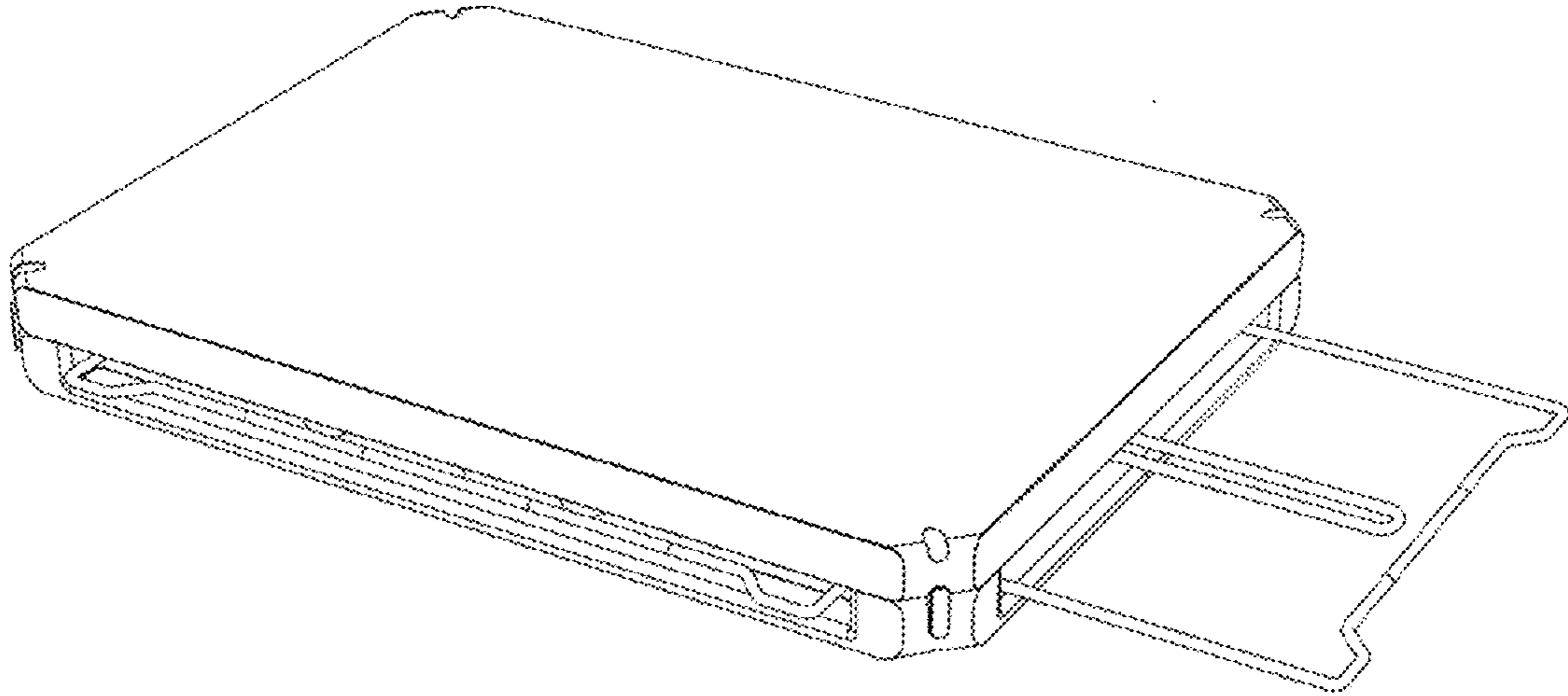

FIG. 13

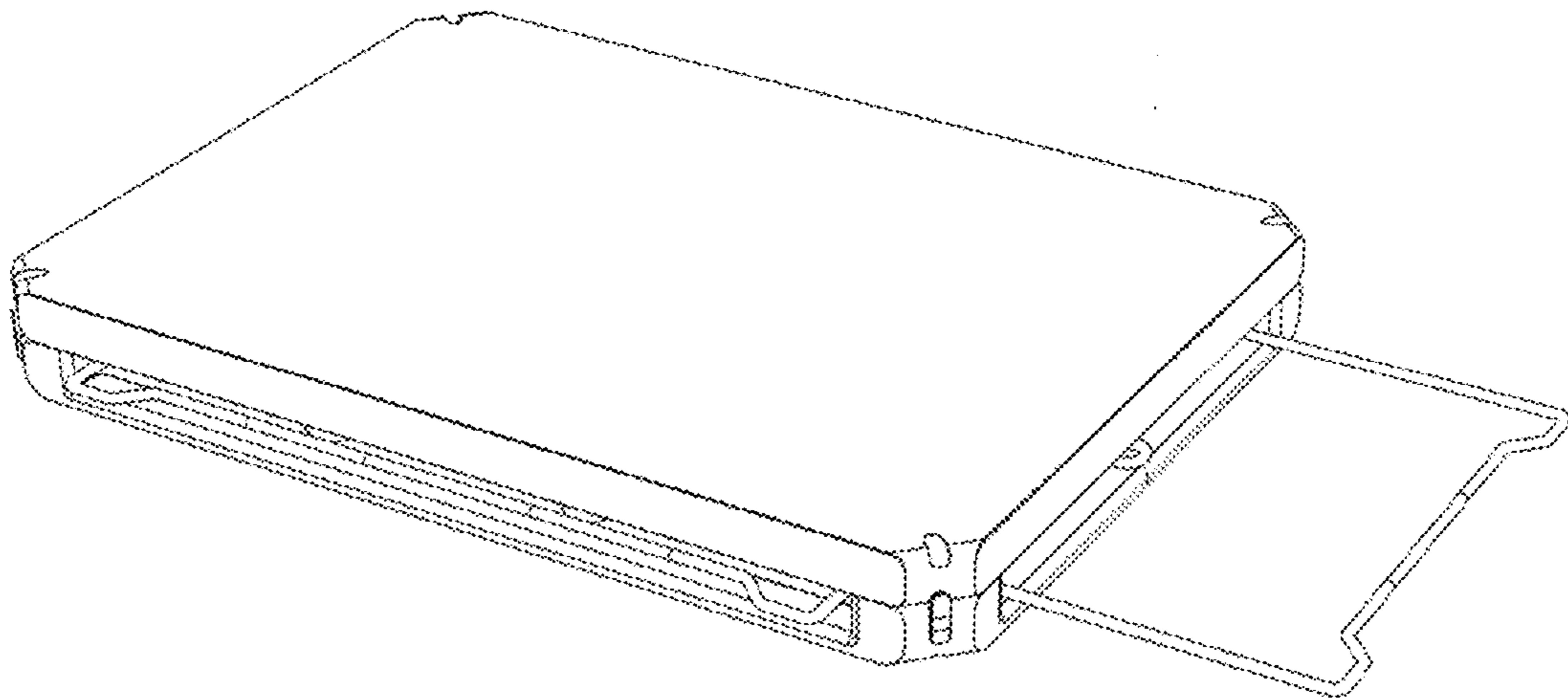

FIG. 14