



US00D745725S

(12) **United States Design Patent**
McMahan et al.

(10) **Patent No.:** **US D745,725 S**
(45) **Date of Patent:** **** Dec. 15, 2015**

(54) **VEHICLE REAR TAILLAMP**

(56) **References Cited**

(71) Applicant: **GM Global Technology Operations LLC**, Detroit, MI (US)

U.S. PATENT DOCUMENTS

D476,759 S * 7/2003 Lin D26/28
D483,890 S * 12/2003 Lin D26/28
D497,018 S * 10/2004 Lin D26/28
D541,445 S * 4/2007 Lin D26/28

(72) Inventors: **Robert B. McMahan**, Bloomfield Hills, MI (US); **Brendon C. Mackay**, Shelby Township, MI (US); **Tyler L. H. Moffett**, Detroit, MI (US)

OTHER PUBLICATIONS

Design U.S. Appl. No. 29/457,761, filed Jun. 12, 2013; First Named Inventor: Niels Loeb; Title: Vehicle Rearlight; 4 pages.
Design U.S. Appl. No. 29/457,762, filed Jun. 12, 2013; First Named Inventor: Niels Loeb; Title: Vehicle Rearlight; 4 pages.
Design U.S. Appl. No. 29/473,980, filed Nov. 27, 2013; First Named Inventor: Louis D. Thole; Title: Vehicle Rear Taillamp; 3 pages.
Design U.S. Appl. No. 29/491,286, filed May 20, 2014; First Named Inventor: Robert B. McMahan; Title: Vehicle Body Exterior; 7 pages.
Design U.S. Appl. No. 29/501,210, filed Sep. 2, 2014; First Named Inventor: Robert E. Boniface; Title: Vehicle Rearlight; 3 pages.

(73) Assignee: **GM Global Technology Operations LLC**, Detroit, MI (US)

(**) Term: **14 Years**

* cited by examiner

(21) Appl. No.: **29/503,855**

Primary Examiner — Marcus Jackson

(22) Filed: **Sep. 30, 2014**

(74) *Attorney, Agent, or Firm* — Lionel D. Anderson; Reising Ethington P.C.

(51) **LOC (10) Cl.** **26-06**

(57) **CLAIM**

(52) **U.S. Cl.**

The ornamental design for a vehicle rear taillamp, as shown and described.

USPC **D26/28**

DESCRIPTION

(58) **Field of Classification Search**

USPC D26/28-36; 362/459-468, 475-478, 362/485-487

FIG. 1 is a perspective view of a vehicle rear taillamp; FIG. 2 is a front view thereof; FIG. 3 is a side elevation view thereof; and, FIG. 4 is a top plan view thereof.

CPC F21S 48/00; F21S 48/225; F21S 48/1233; F21S 48/1266; F21S 48/1388; F21S 48/2268; F21V 21/04

In the drawings, the portions shown by broken lines form no part of the claimed design.

See application file for complete search history.

1 Claim, 2 Drawing Sheets

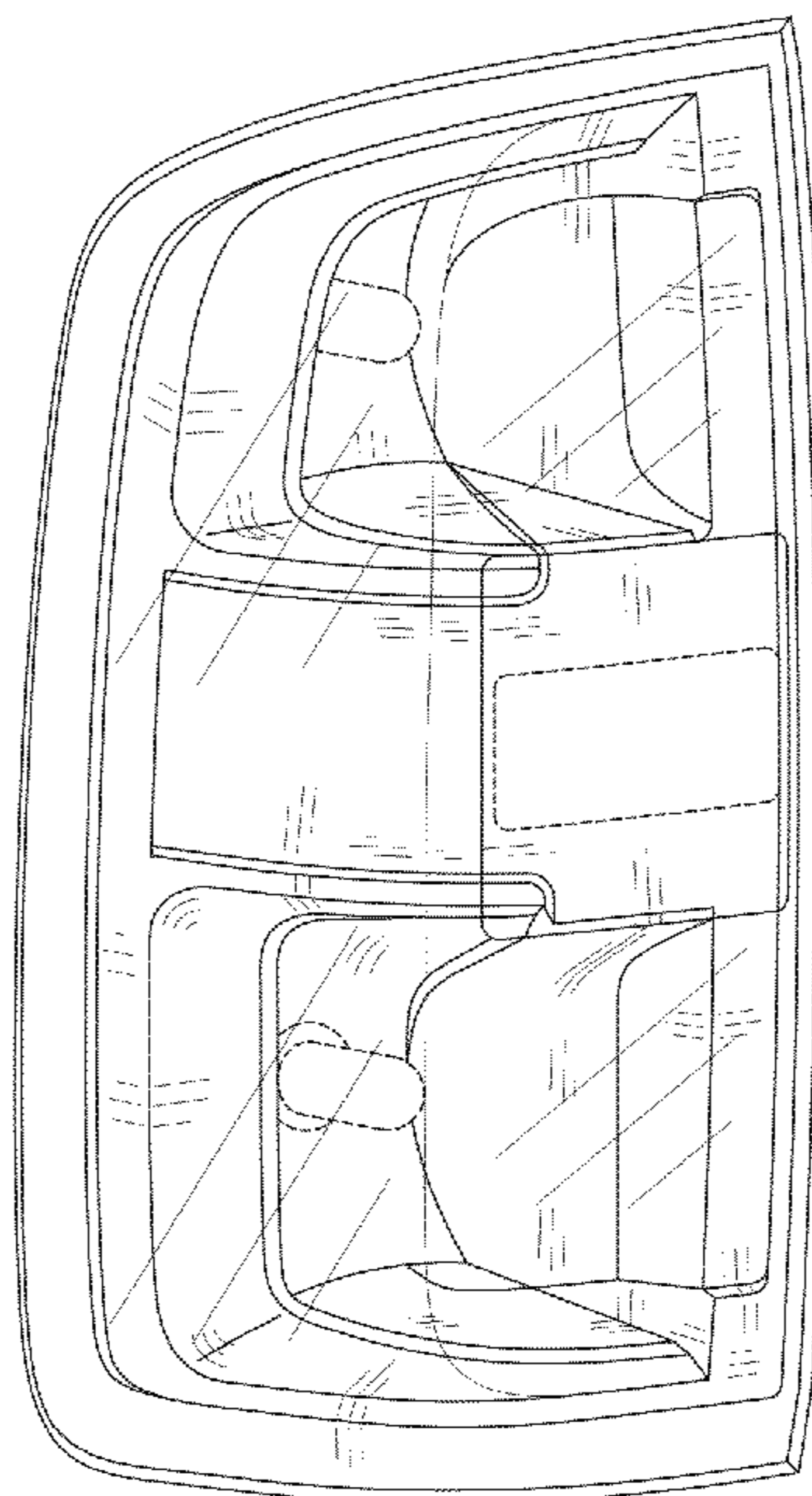

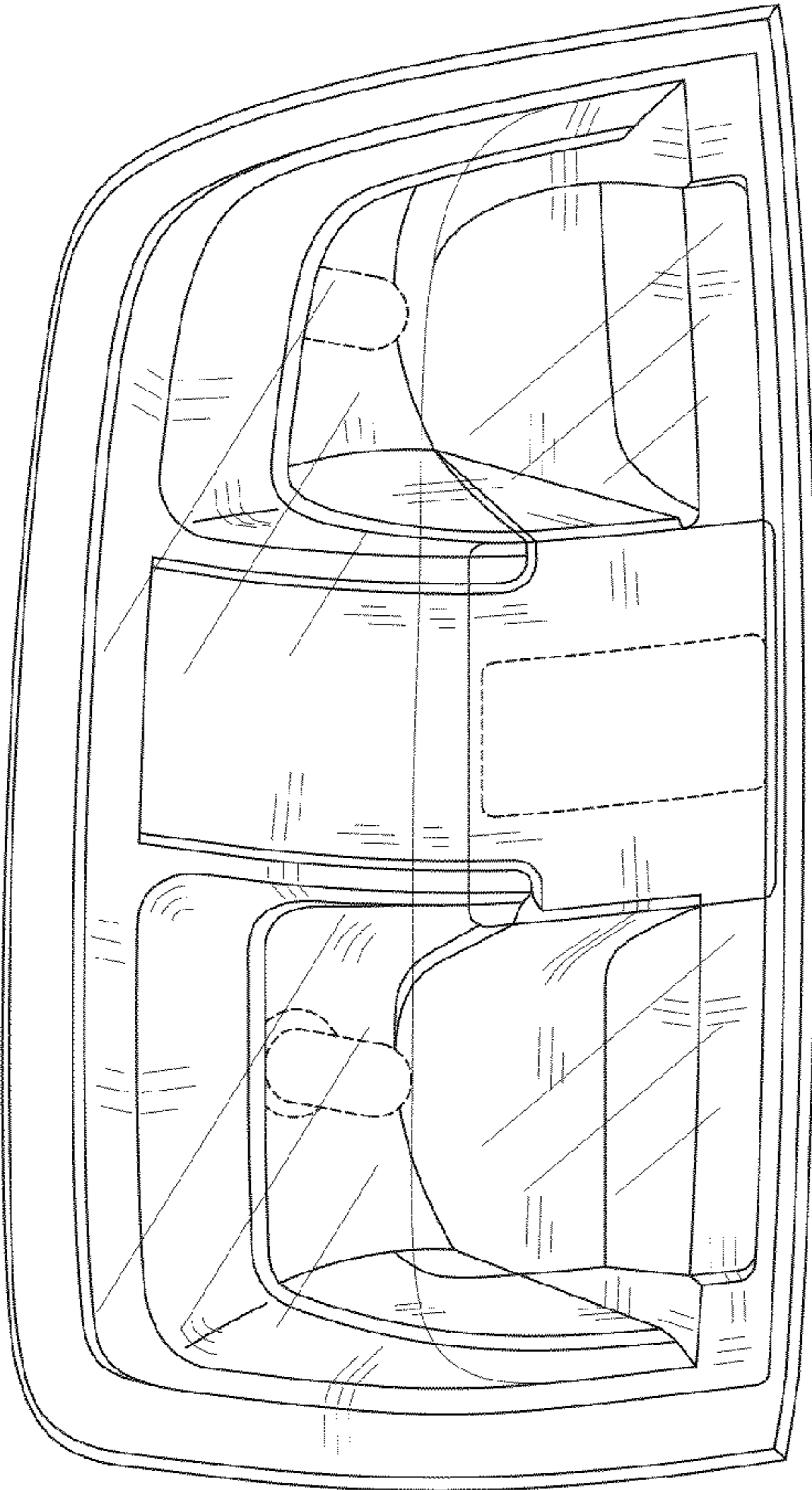

Fig-1

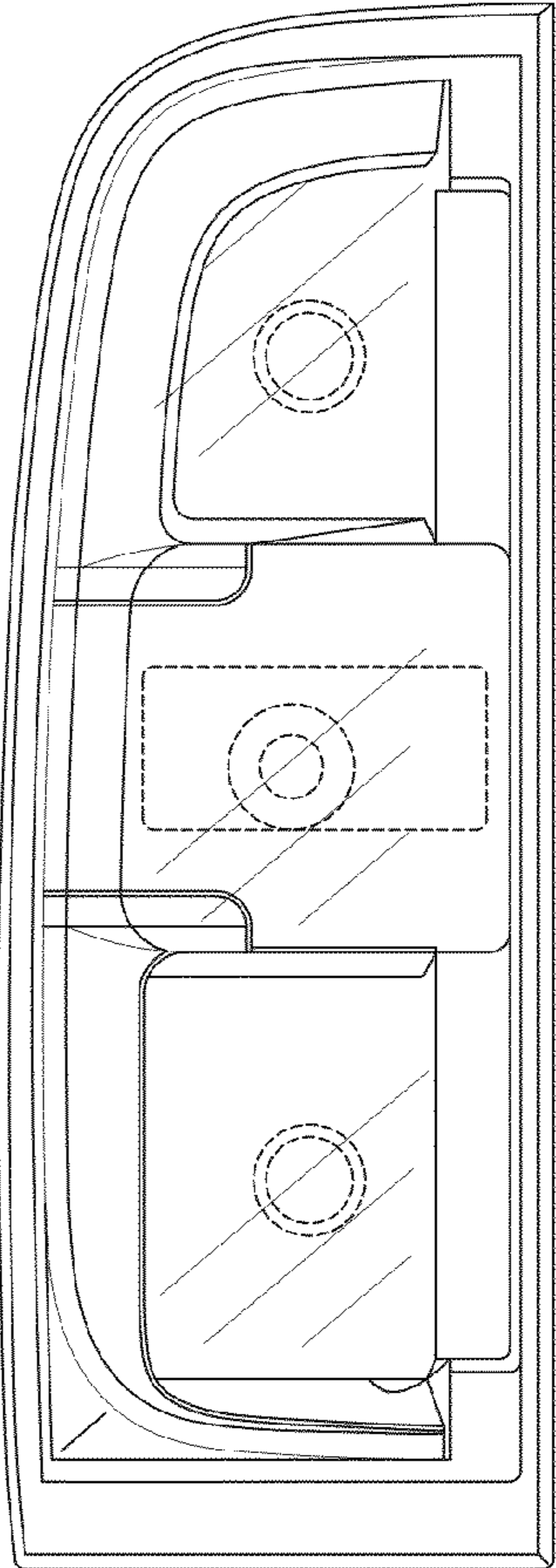

Fig-2

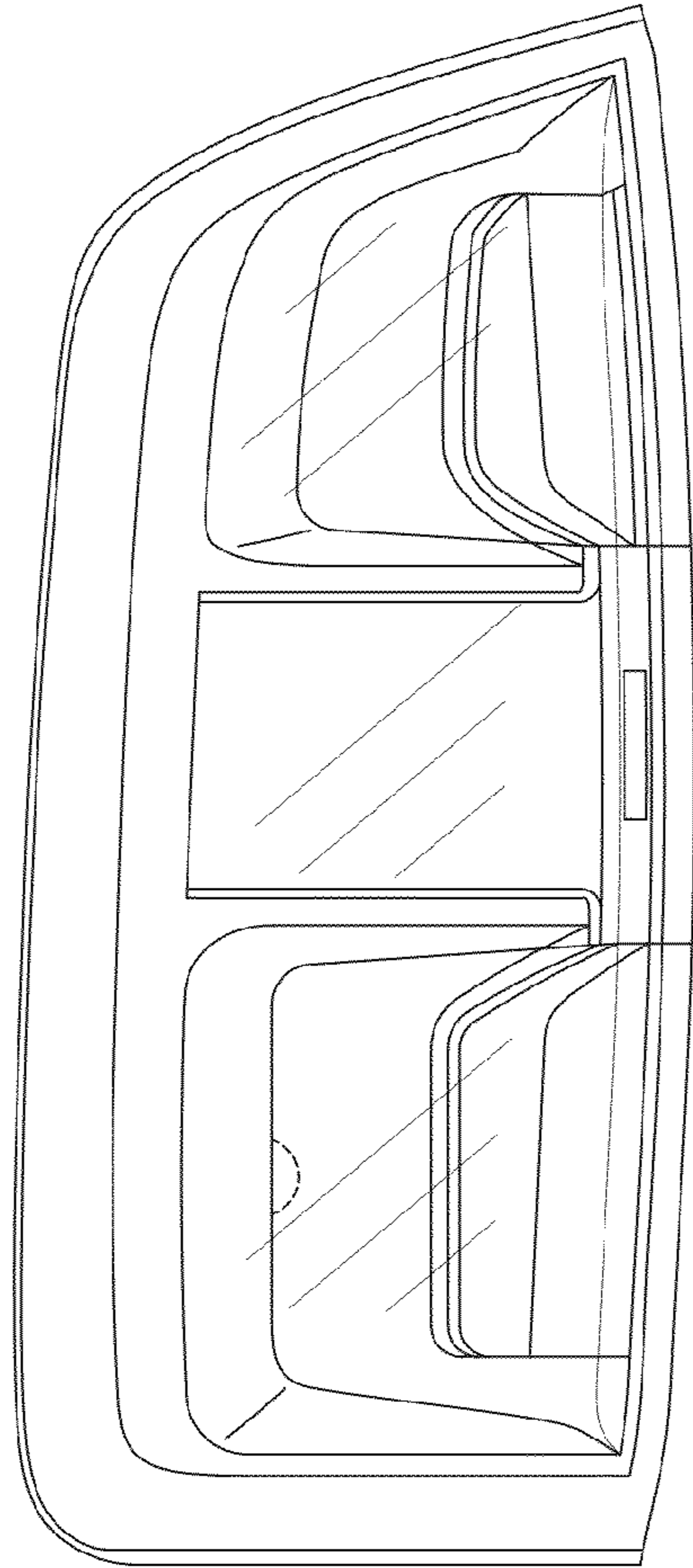

Fig-3

Fig-4

