



US00D745714S

(12) **United States Design Patent**  
**Rigolio**

(10) **Patent No.:** **US D745,714 S**

(45) **Date of Patent:** **\*\* Dec. 15, 2015**

(54) **MOTORCYCLE INDICATOR LIGHT**

(71) Applicant: **Fabrizio Rigolio**, Lonate Pozzolo VA  
(IT)

(72) Inventor: **Fabrizio Rigolio**, Lonate Pozzolo VA  
(IT)

(73) Assignee: **Rizoma IP S.r.l.**, Lonate Pozzolo VA  
(IT)

(\*\*) Term: **14 Years**

(21) Appl. No.: **29/490,888**

(22) Filed: **May 15, 2014**

(30) **Foreign Application Priority Data**

Nov. 15, 2013 (EM) ..... 002346403-0001

(51) **LOC (10) Cl.** ..... **26-06**

(52) **U.S. Cl.**  
USPC ..... **D26/28**

(58) **Field of Classification Search**  
USPC ..... D12/114; D26/24, 26, 28, 30-31, 36;  
362/459, 473, 475, 478, 485, 516, 540,  
362/542  
CPC ..... A63C 2203/14; B62J 6/00; B62J 6/02;  
B61L 15/02; B60Q 1/34; B60Q 1/305; F21S  
48/1388  
See application file for complete search history.

(56) **References Cited**

**U.S. PATENT DOCUMENTS**

5,820,254 A \* 10/1998 Duenas ..... 362/473  
D455,852 S \* 4/2002 Sawabe et al. .... D26/28  
D499,824 S \* 12/2004 Wu ..... D26/28  
D501,571 S \* 2/2005 Kouchi et al. .... D26/28

D511,016 S \* 10/2005 Tamura et al. .... D26/28  
D517,708 S \* 3/2006 Phillips et al. .... D26/28  
D518,207 S \* 3/2006 Wong et al. .... D26/28  
D549,605 S \* 8/2007 Harrell ..... D10/111  
D587,827 S \* 3/2009 Tsukui et al. .... D26/28  
D590,079 S \* 4/2009 Higashikawa ..... D26/28  
D592,328 S \* 5/2009 Chen et al. .... D26/28  
D593,234 S \* 5/2009 Matsumura ..... D26/30  
D602,184 S \* 10/2009 Wu ..... D26/28

**OTHER PUBLICATIONS**

“Rizoma—2014 Catalogue.” rizoma.com—p. 58., Jan. 13, 2014  
[online], [retrieved on Nov. 8, 2014]. Retrieved from the Internet  
<URL: [http://www.rizoma.com/webobjrizoma/CATALOG/CAT\\_2014/RIZOMA\\_CATALOGUE2014\\_WEB\\_EN.pdf](http://www.rizoma.com/webobjrizoma/CATALOG/CAT_2014/RIZOMA_CATALOGUE2014_WEB_EN.pdf)>.\*

\* cited by examiner

*Primary Examiner* — Philip S Hyder

*Assistant Examiner* — Darlington Ly

(74) *Attorney, Agent, or Firm* — Bay State IP, LLC

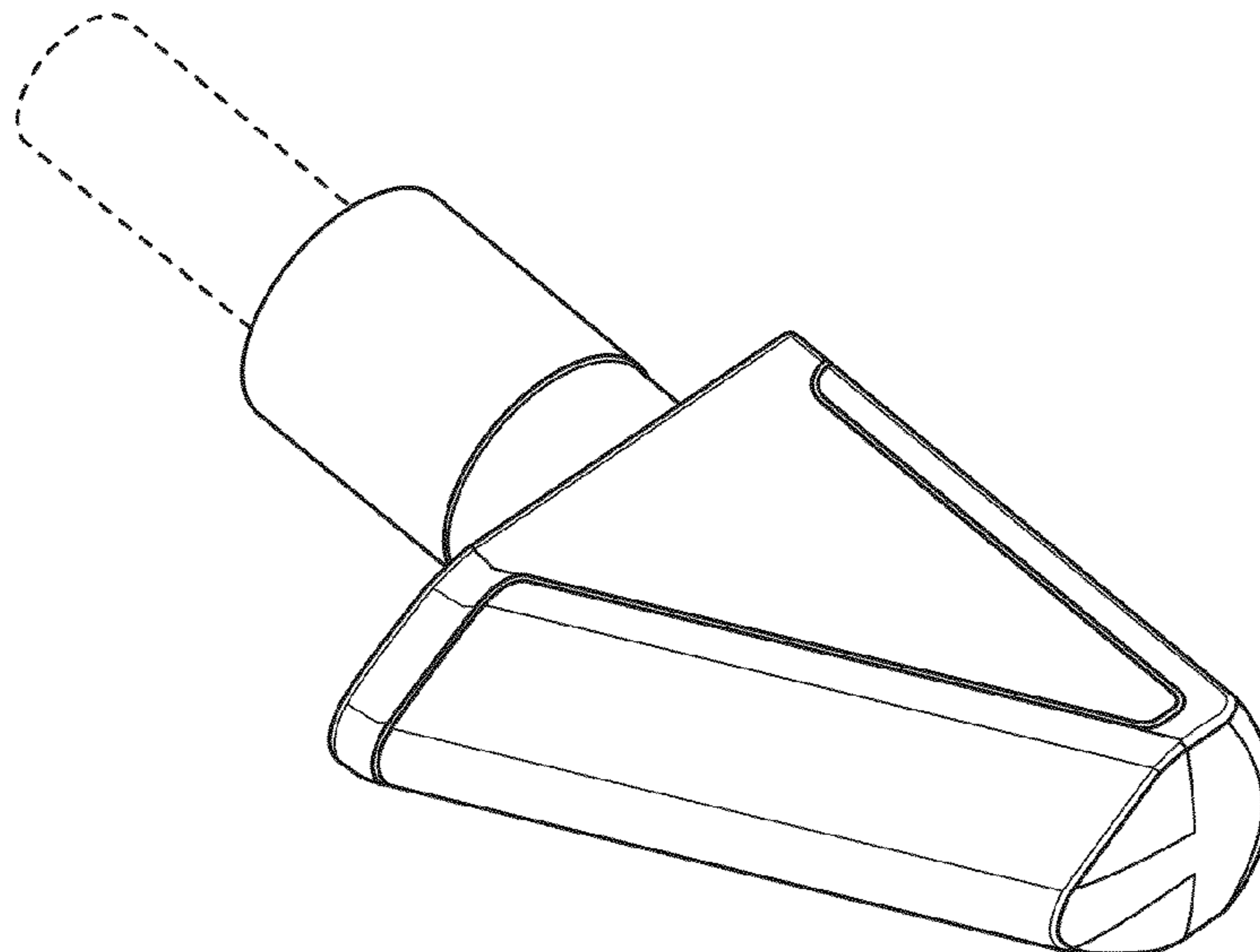
(57) **CLAIM**

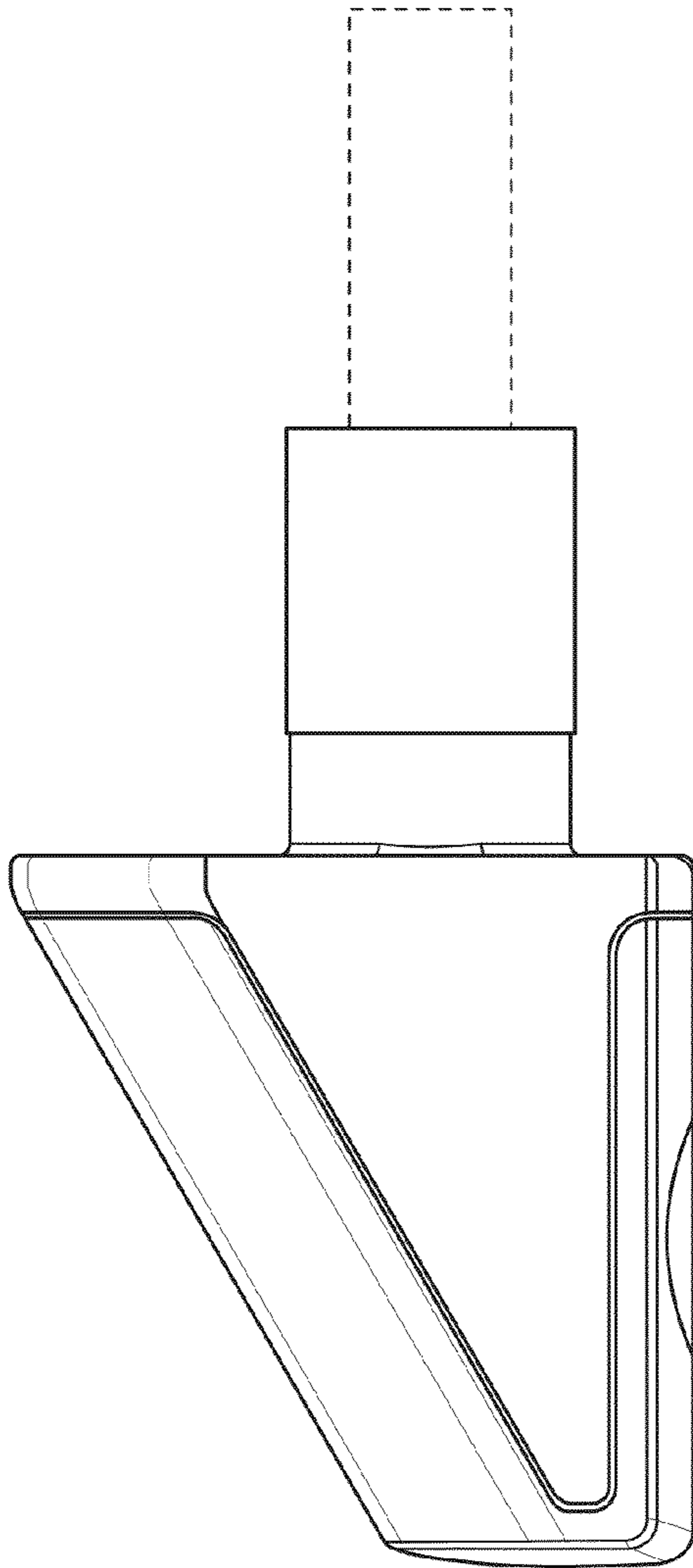
I claim the ornamental design for an motorcycle indicator light, as shown and described.

**DESCRIPTION**

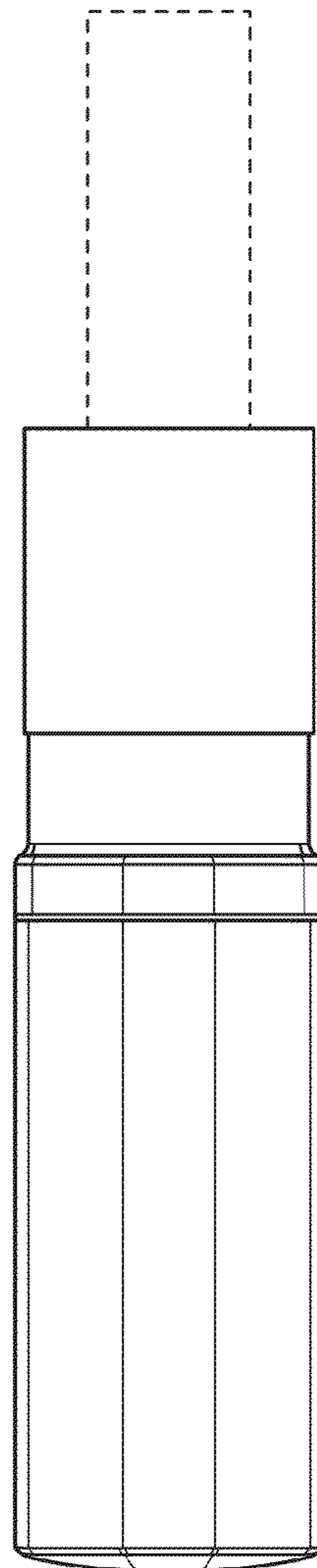
FIG. 1 is a rotated isometric top view showing my new design;  
FIG. 2 is a front elevation view thereof;  
FIG. 3 is a top, front and right-side perspective view thereof;  
FIG. 4 is a top, front, and left-side perspective view thereof;  
and,  
FIG. 5 is a rear elevation view thereof.  
The broken lines showing an extension of the motorcycle indicator light in FIGS. 1-5 have been shown for the purpose of illustrating environment that forms no part of the claimed design.

**1 Claim, 3 Drawing Sheets**

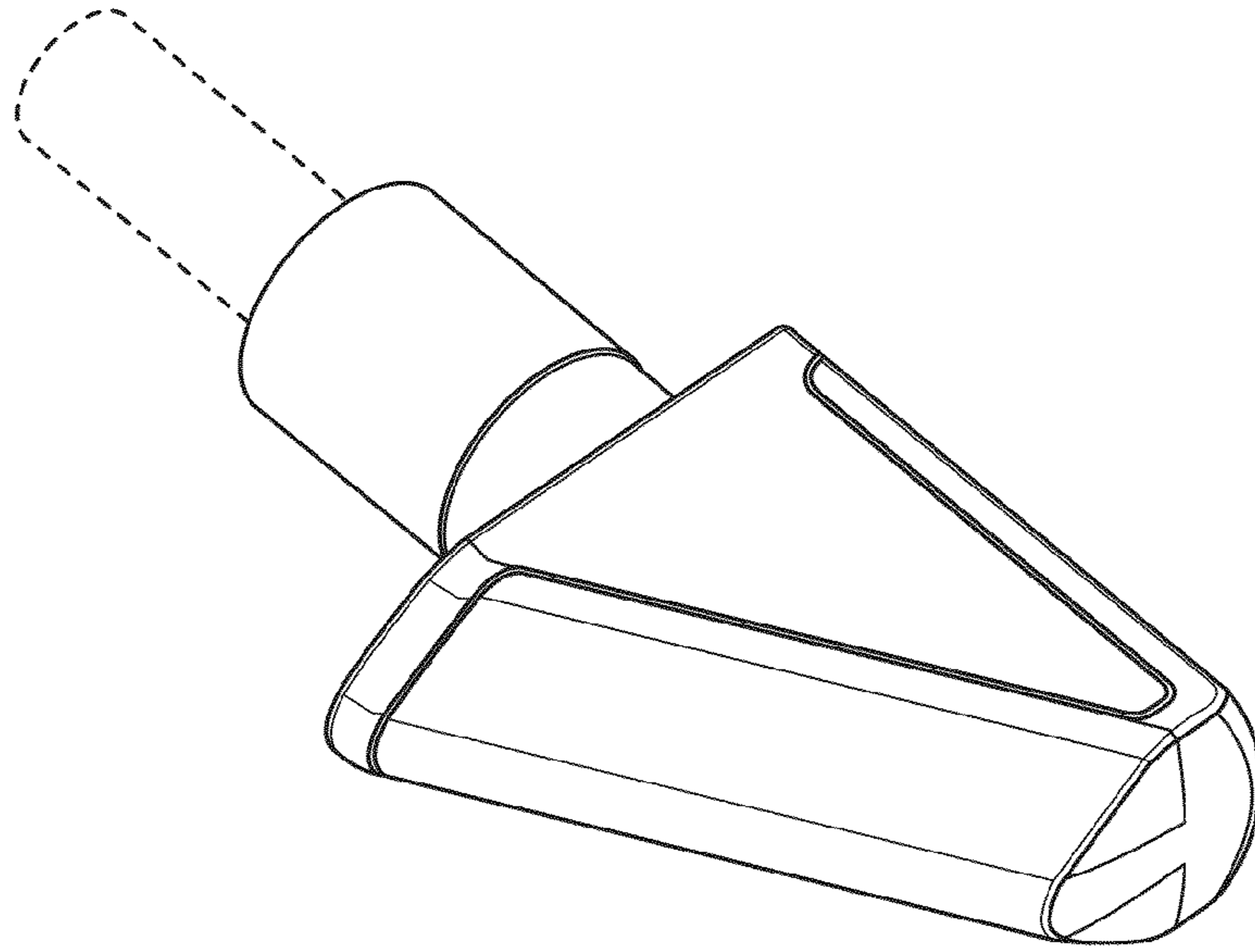




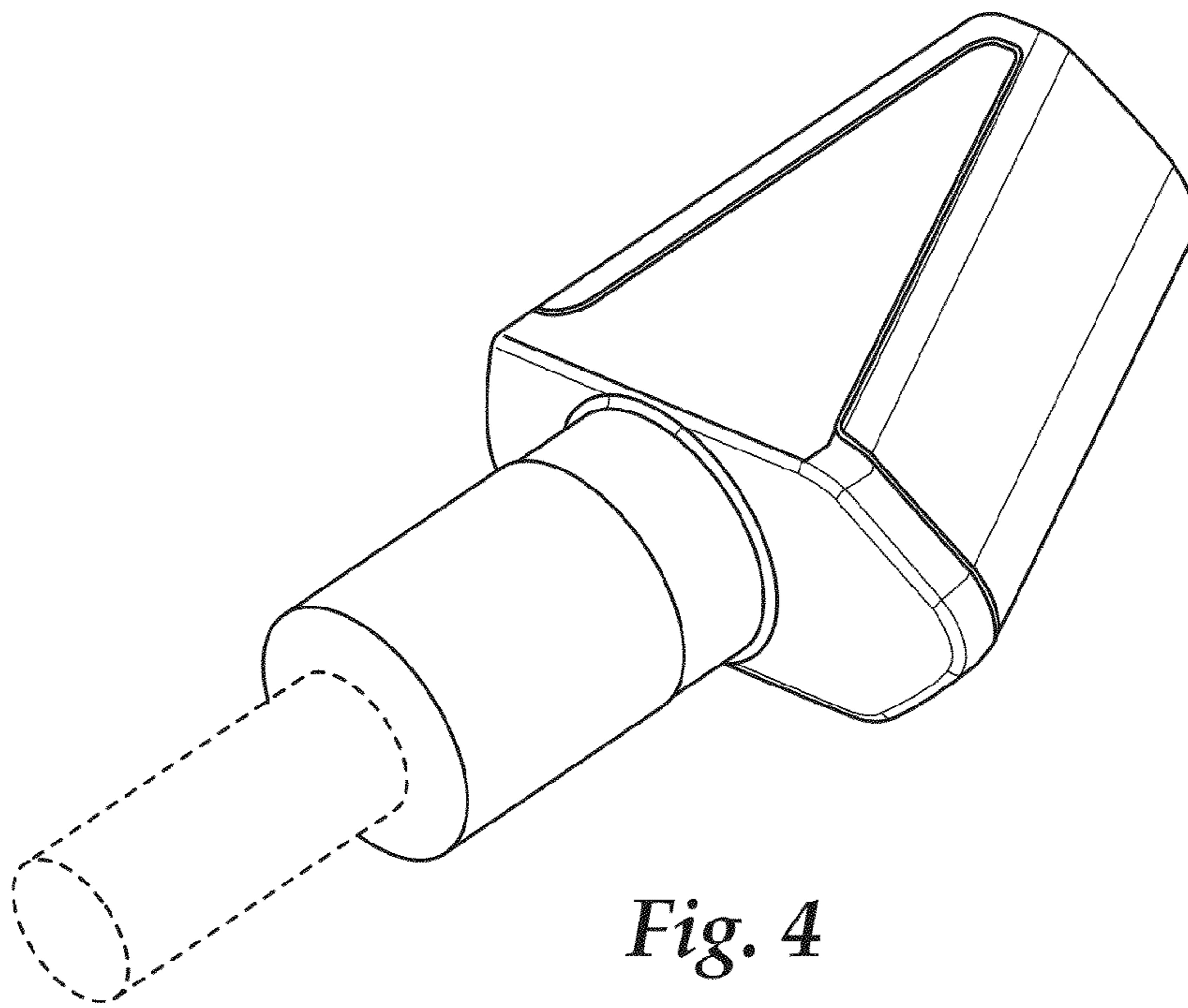
*Fig. 1*



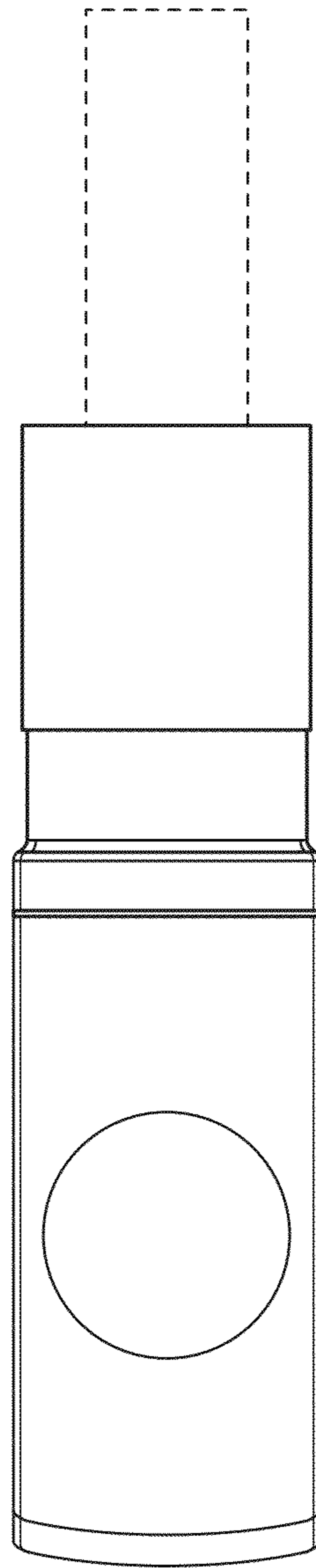
*Fig. 2*



*Fig. 3*



*Fig. 4*



*Fig. 5*