



US00D745422S

(12) **United States Design Patent**
Lanini

(10) **Patent No.:** US D745,422 S
(45) **Date of Patent:** ** Dec. 15, 2015

(54) **PARKING SENSOR RE-LOCATOR FOR A VEHICLE**
(71) Applicant: **Westin Automotive Products, Inc.**, San Dimas, CA (US)
(72) Inventor: **Jeremy Lanini**, Alta Loma, CA (US)
(73) Assignee: **WESTIN AUTOMOTIVE PRODUCTS, INC.**, San Dimas, CA (US)
(**) Term: **14 Years**

(21) Appl. No.: **29/507,431**
(22) Filed: **Oct. 28, 2014**
(51) **LOC (10) Cl.** **10-04**
(52) **U.S. Cl.**
USPC **D10/70**
(58) **Field of Classification Search**
USPC D10/65, 70
CPC G08G 1/123; G08G 1/127; G08G 1/13; G08G 1/133; G08G 1/137; G08G 1/14; G08G 1/141; G08G 1/142; G08G 1/143; G08G 1/144; G08G 1/145; G08G 1/146; G08G 1/147; G08G 1/148; G08G 1/149; G08G 1/005; G01C 21/00
See application file for complete search history.

(56) **References Cited**
U.S. PATENT DOCUMENTS
2010/0318288 A1* 12/2010 Korn et al. 701/201
2012/0299936 A1* 11/2012 Ashjaee et al. 345/501

* cited by examiner

Primary Examiner — Antoine D Davis
(74) Attorney, Agent, or Firm — The Dobrusin Law Firm, PC

(57) **CLAIM**
The ornamental design for a parking sensor re-locator for a vehicle, as shown and described.

DESCRIPTION

FIG. 1 is a perspective view of the parking sensor re-locator for a vehicle showing my new design;
FIG. 2 is a bottom view of the parking sensor re-locator for a vehicle of FIG. 1;
FIG. 3 is a top view of the parking sensor re-locator for a vehicle of FIG. 1;
FIG. 4 is a view of one side of the parking sensor re-locator for a vehicle of FIG. 1;
FIG. 5 is a view of the other side of the parking sensor re-locator for a vehicle of FIG. 1;
FIG. 6 is a front view of the parking sensor re-locator for a vehicle of FIG. 1;
FIG. 7 is a back view of the parking sensor re-locator for a vehicle of FIG. 1;
FIG. 8 is a front view of a vehicle having the parking sensor re-locator for a vehicle of FIG. 1 attached to each of the two sides of the vehicle's grill guard; and
FIG. 9 is a front view of a vehicle having two of the parking sensor re-locator for a vehicle of FIG. 1 attached to a winch tray which is attached to a grill guard of a vehicle; and,
FIG. 10 is a front view of a vehicle having parking sensor re-locator for a vehicle of FIG. 1 attached to (i) the vehicle's winch tray, and (ii) to each of two sides of the vehicle's grill guard.

The broken lines showing of environment is for illustrative purposes only and forms no part of the claimed design.

1 Claim, 5 Drawing Sheets

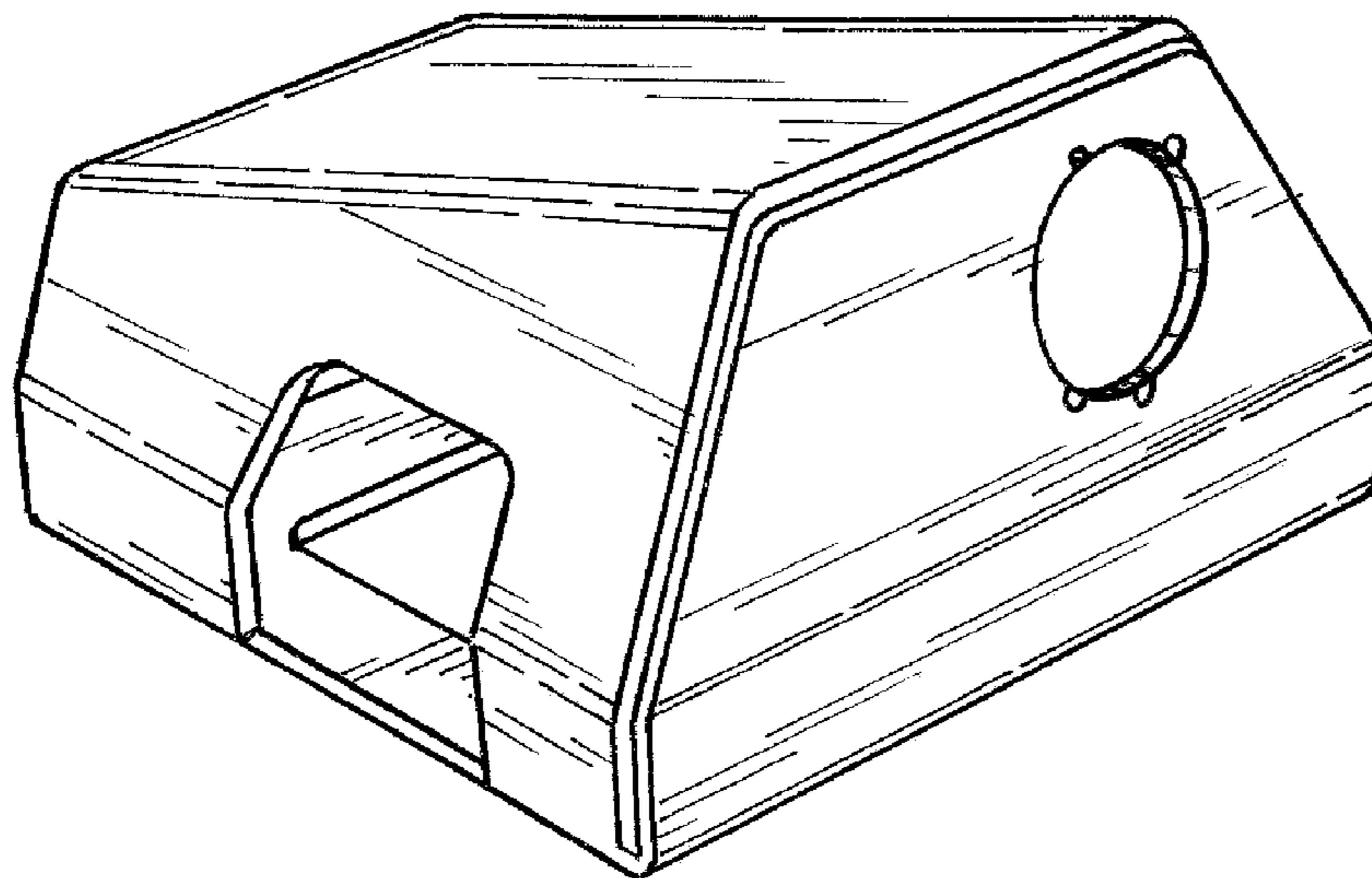

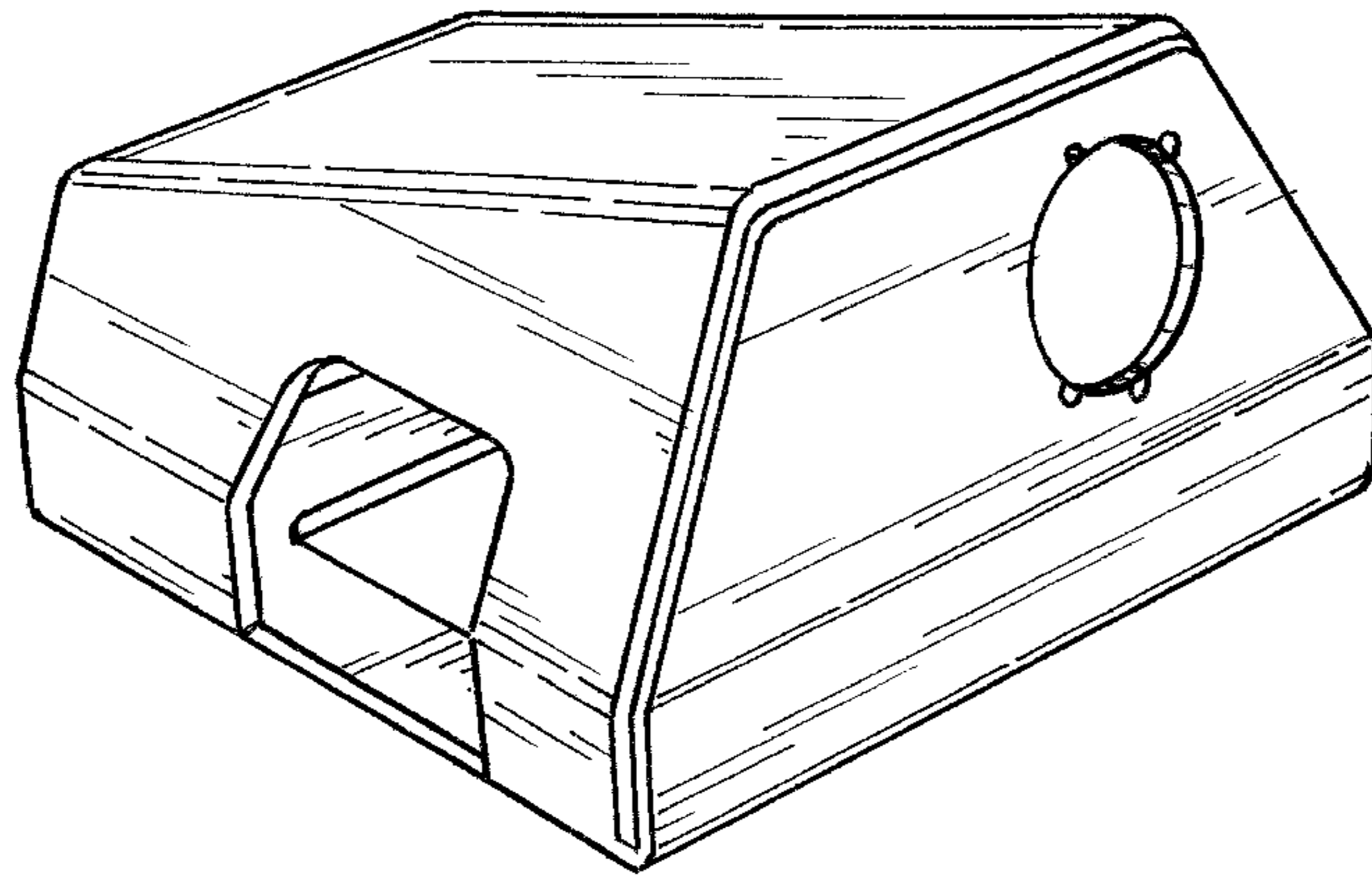

FIG. 1

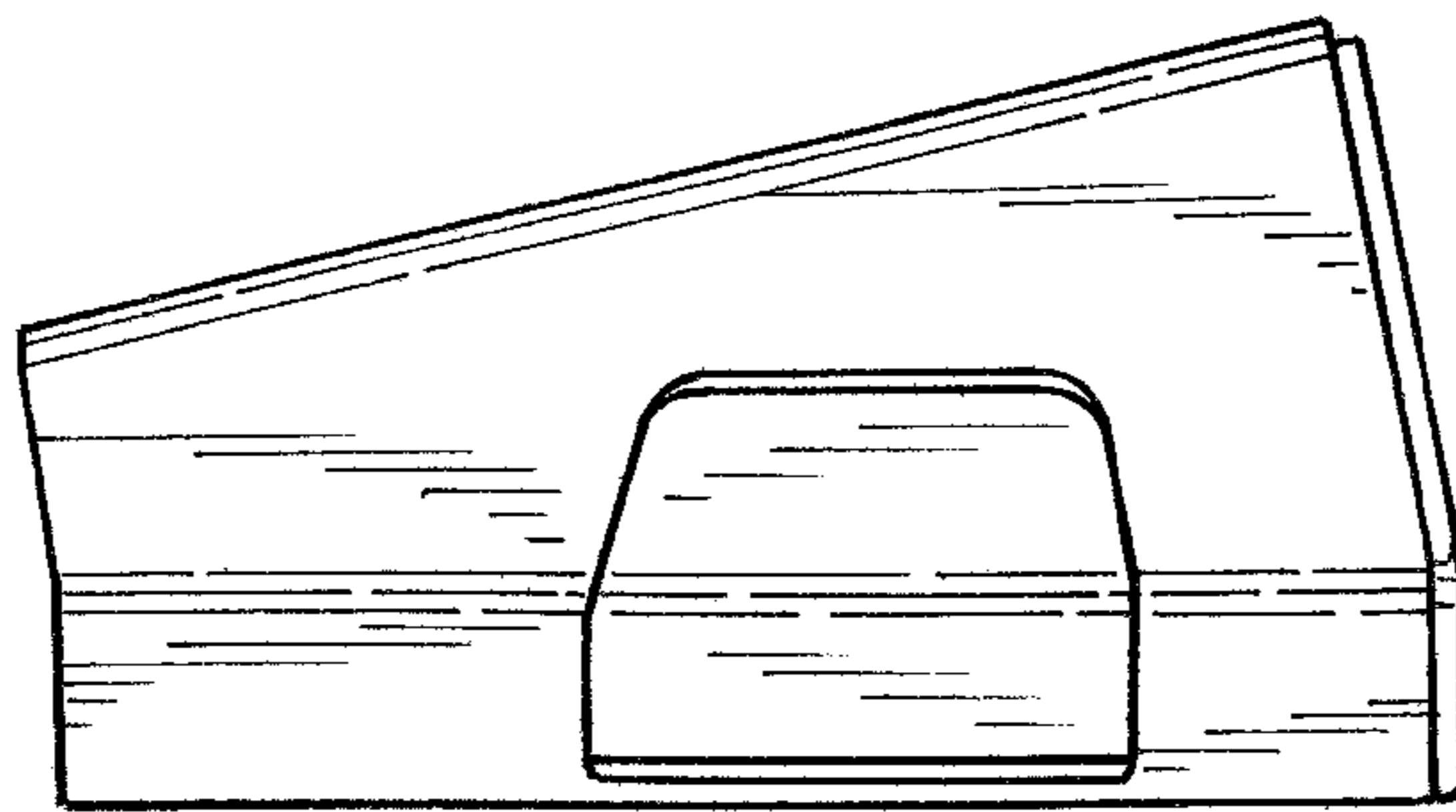

FIG. 2

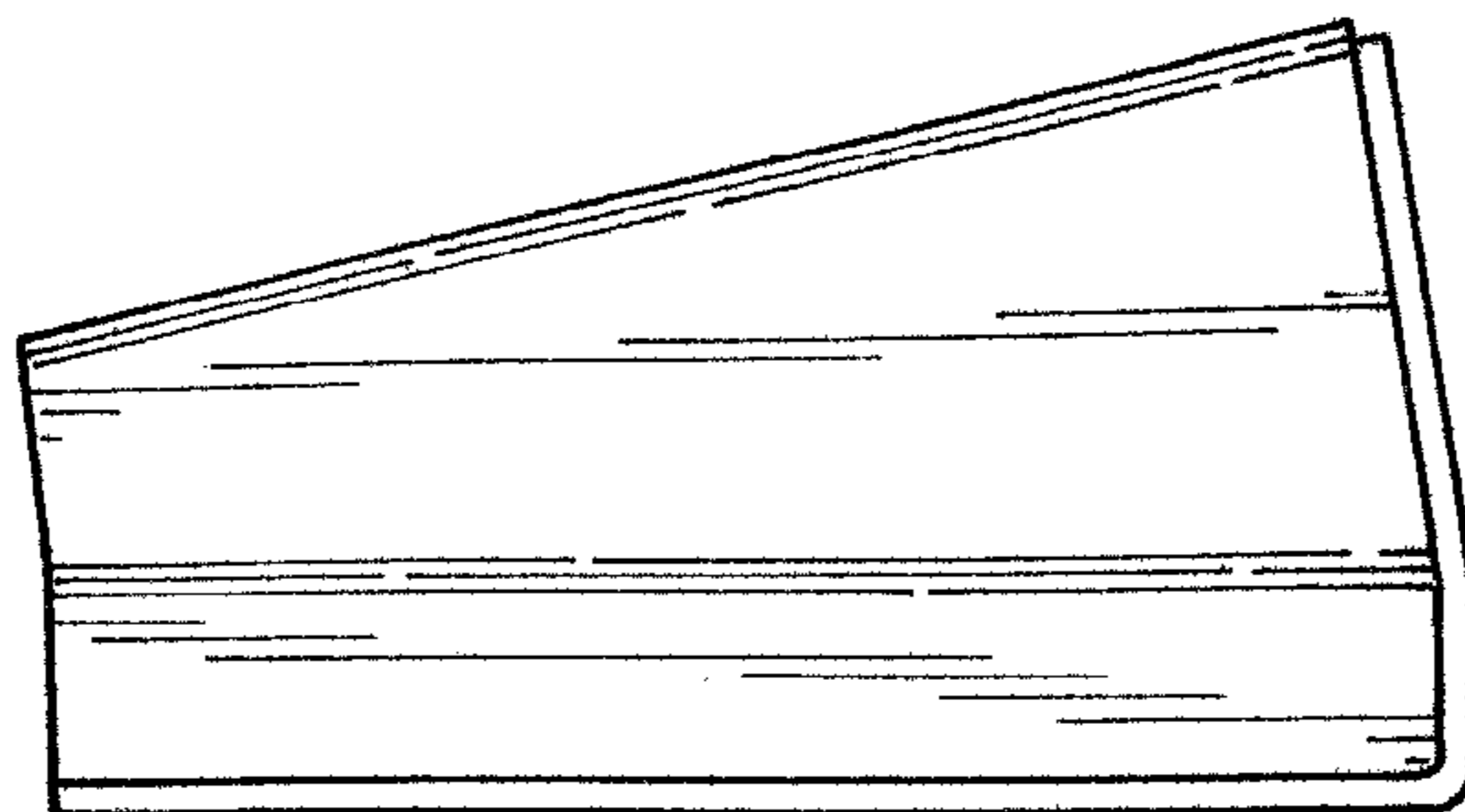

FIG. 3

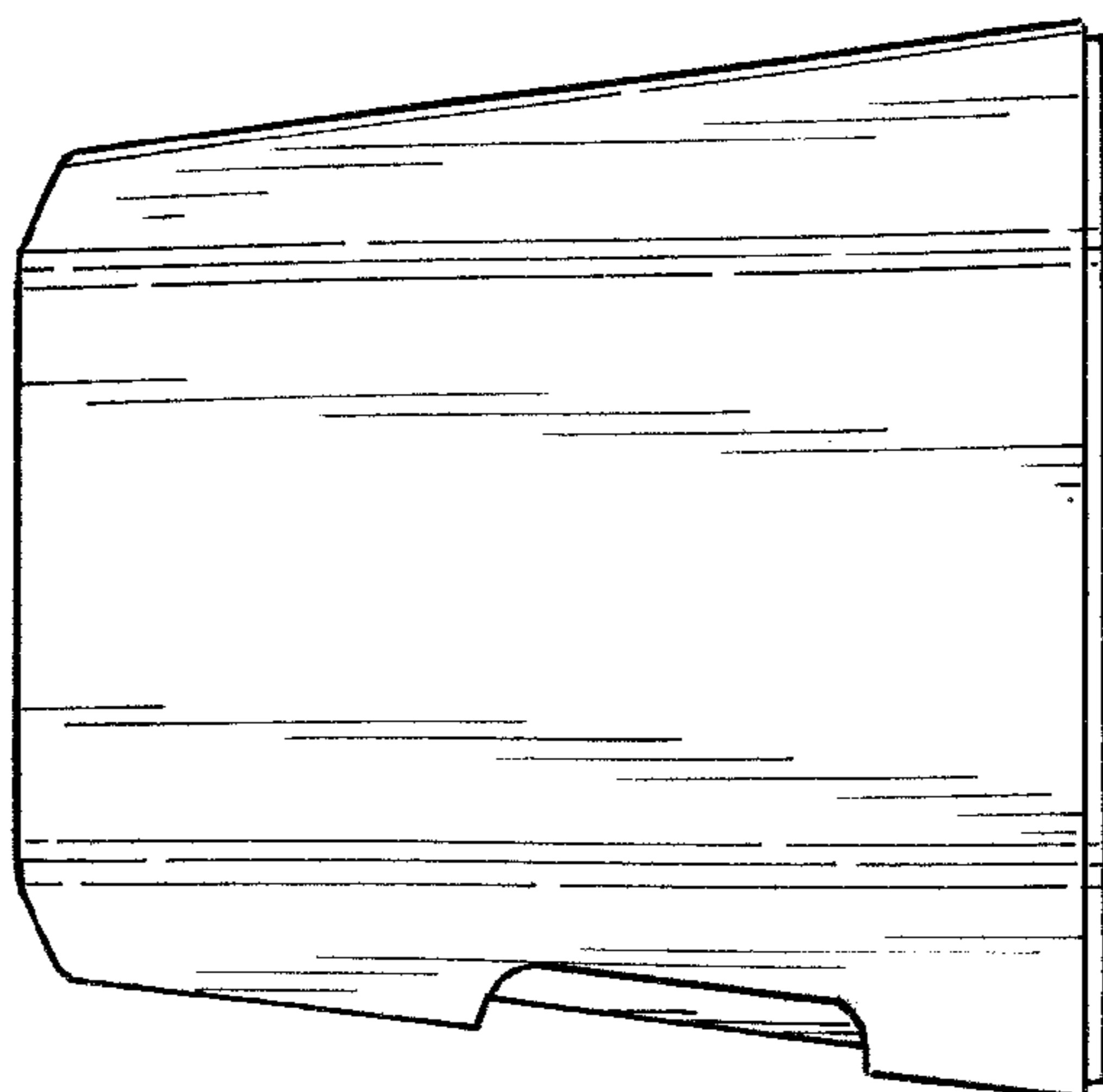

FIG. 4

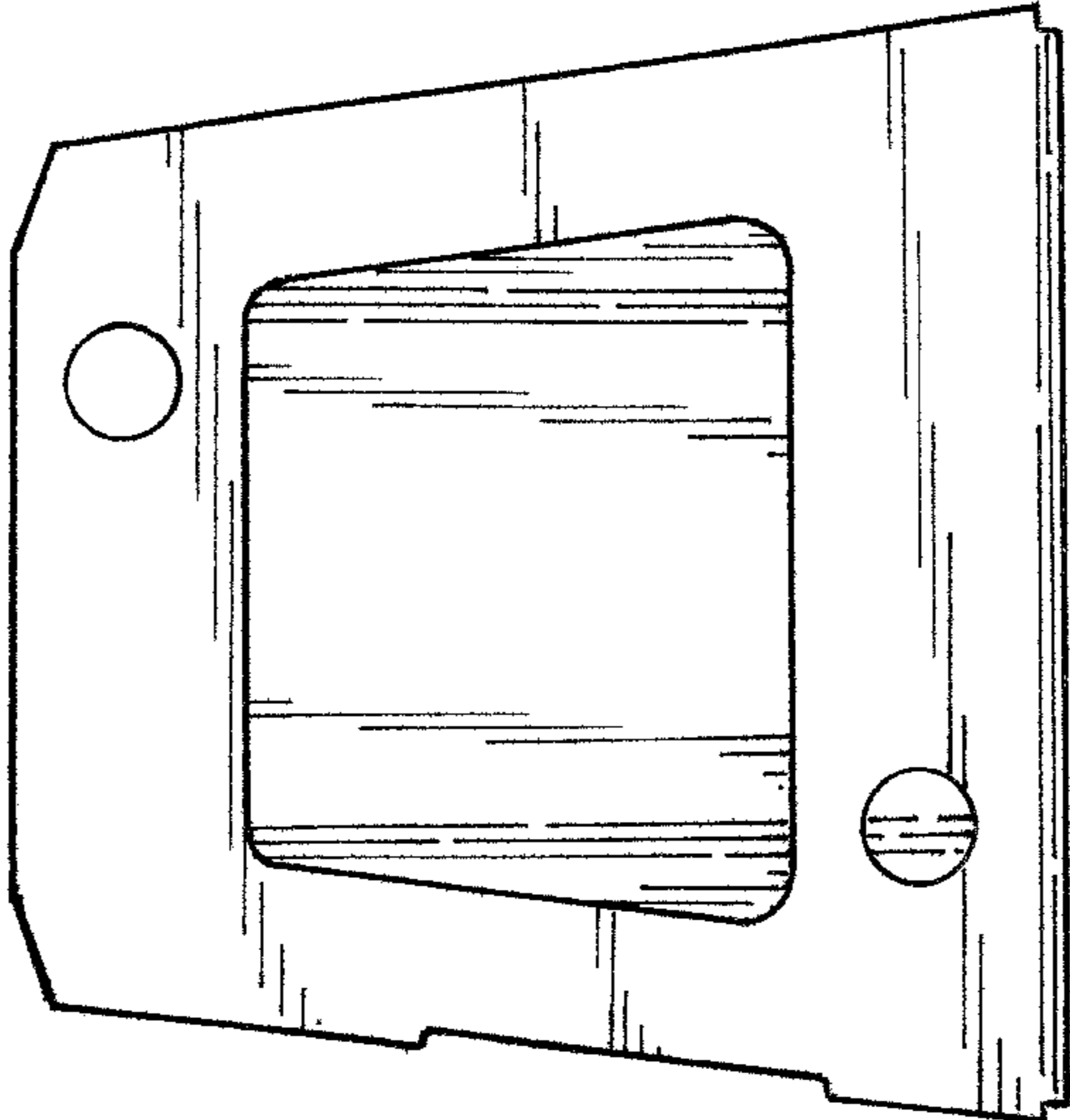

FIG. 5

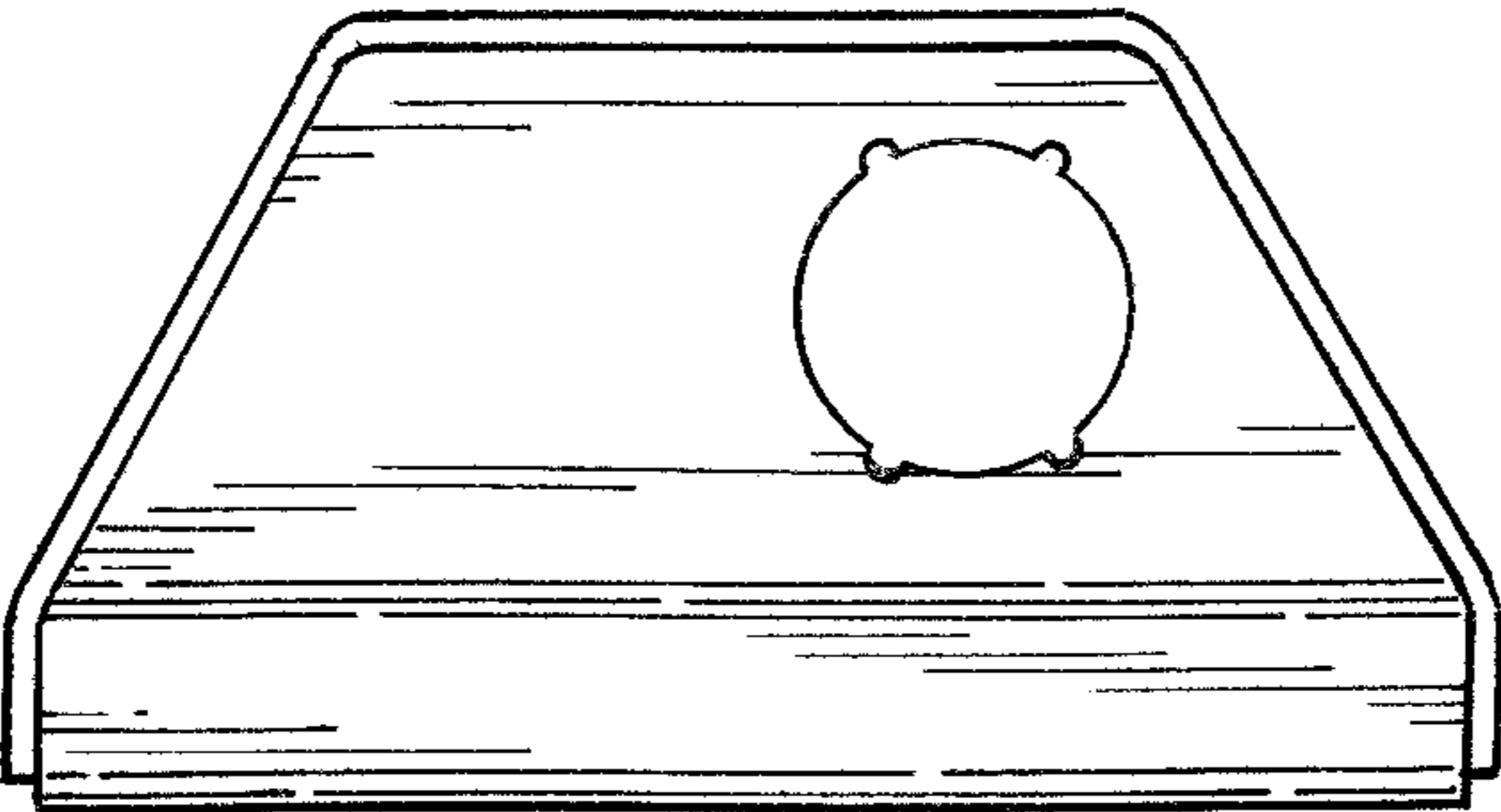

FIG. 6

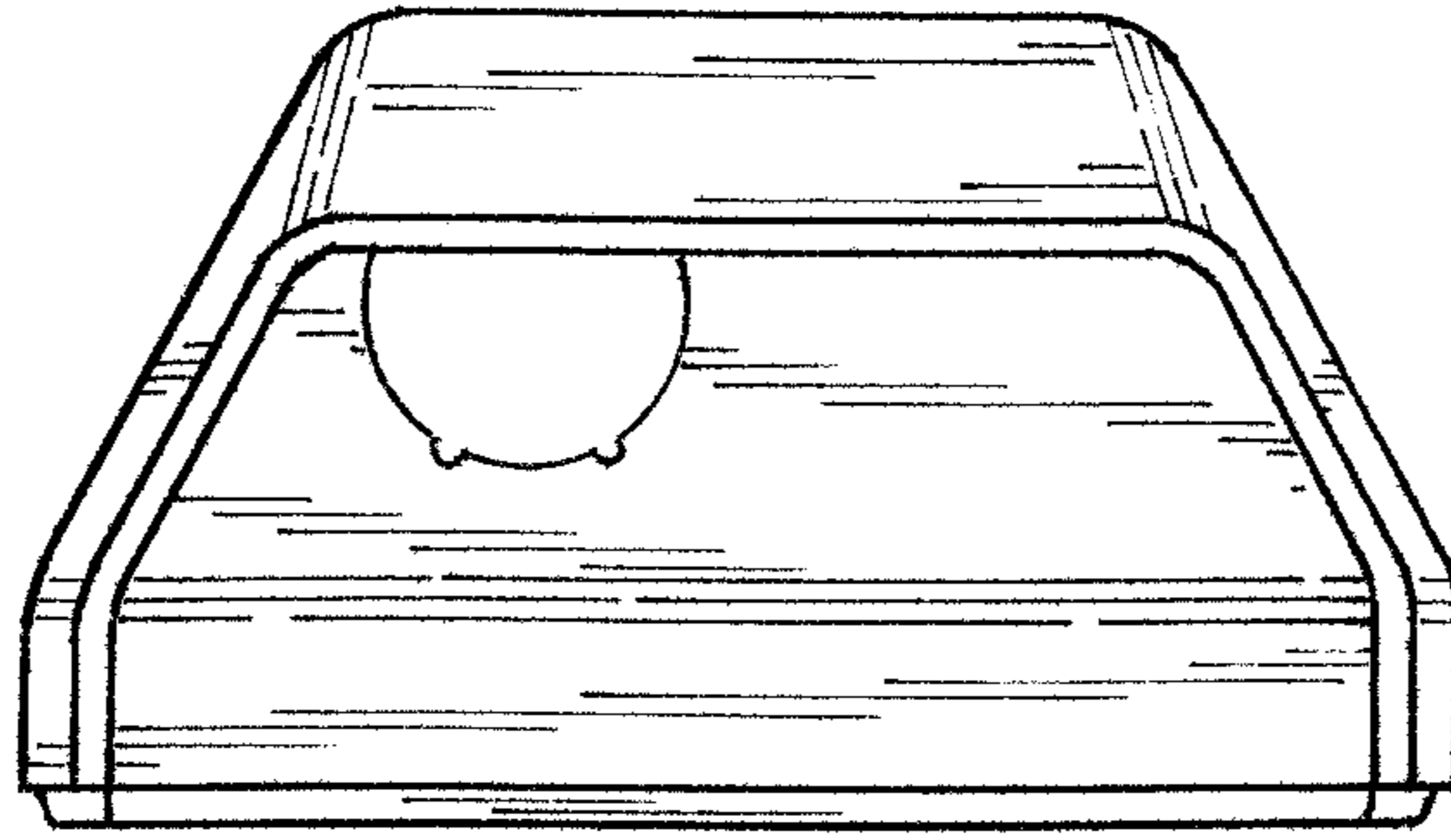

FIG. 7

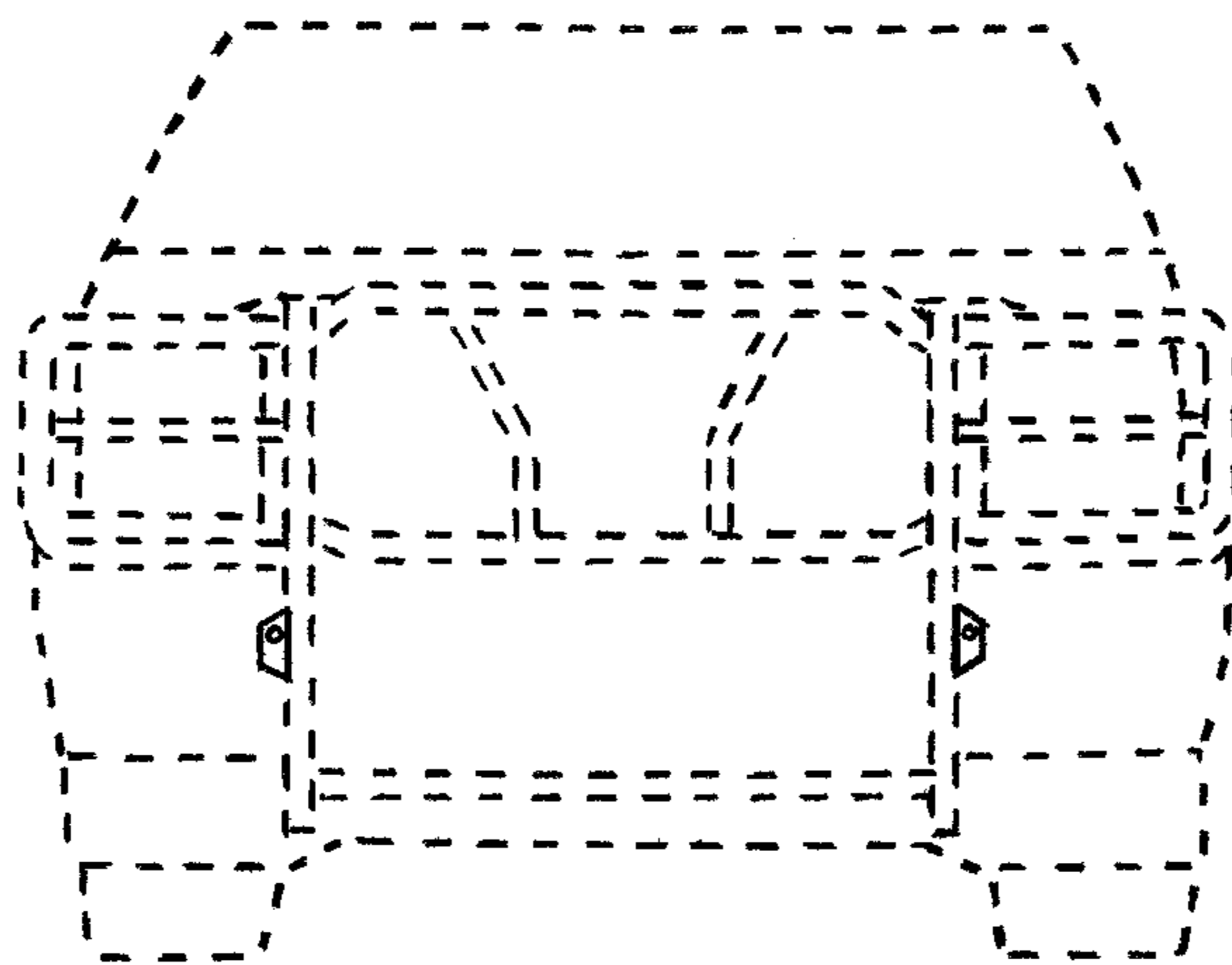

FIG. 8

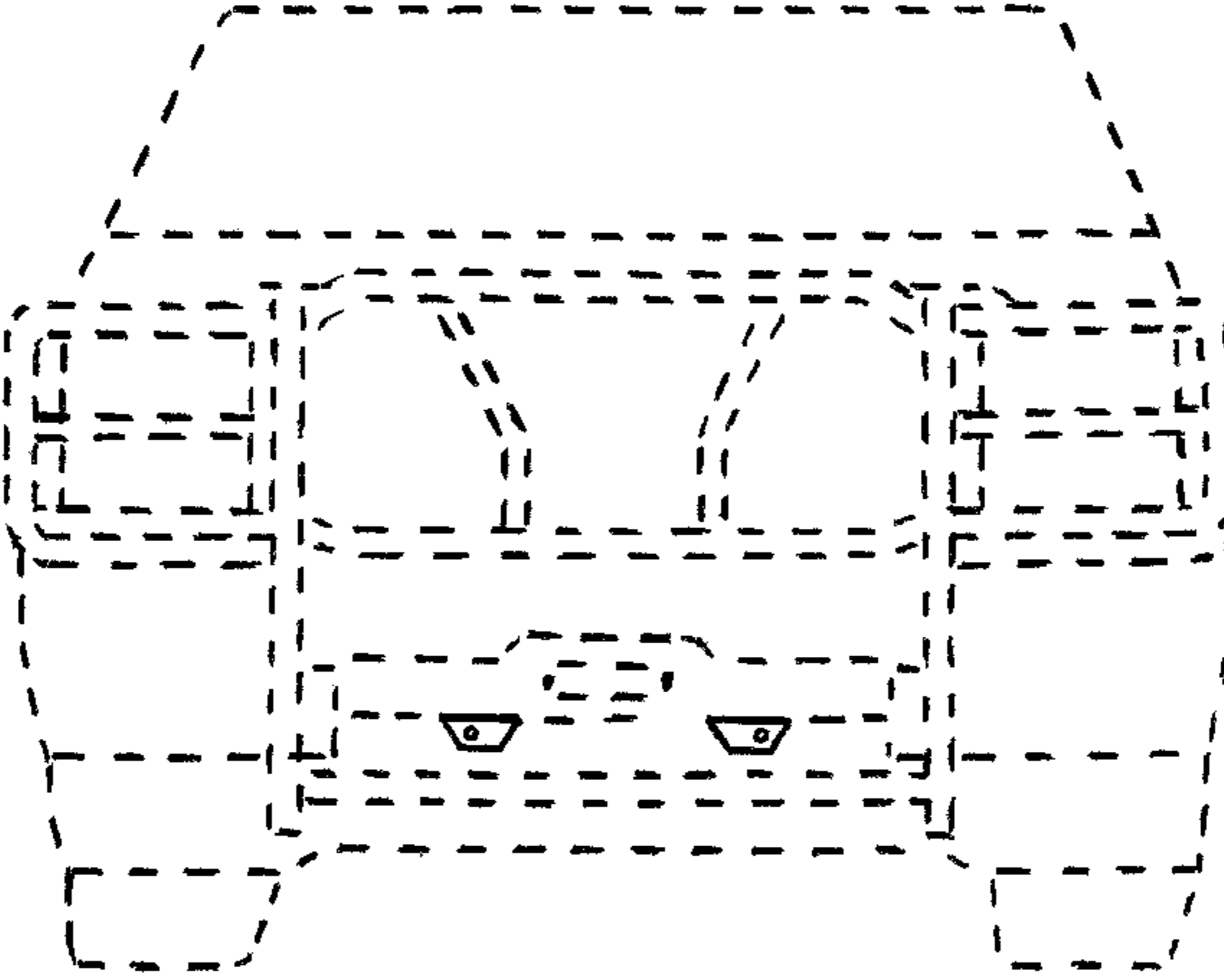

FIG. 9

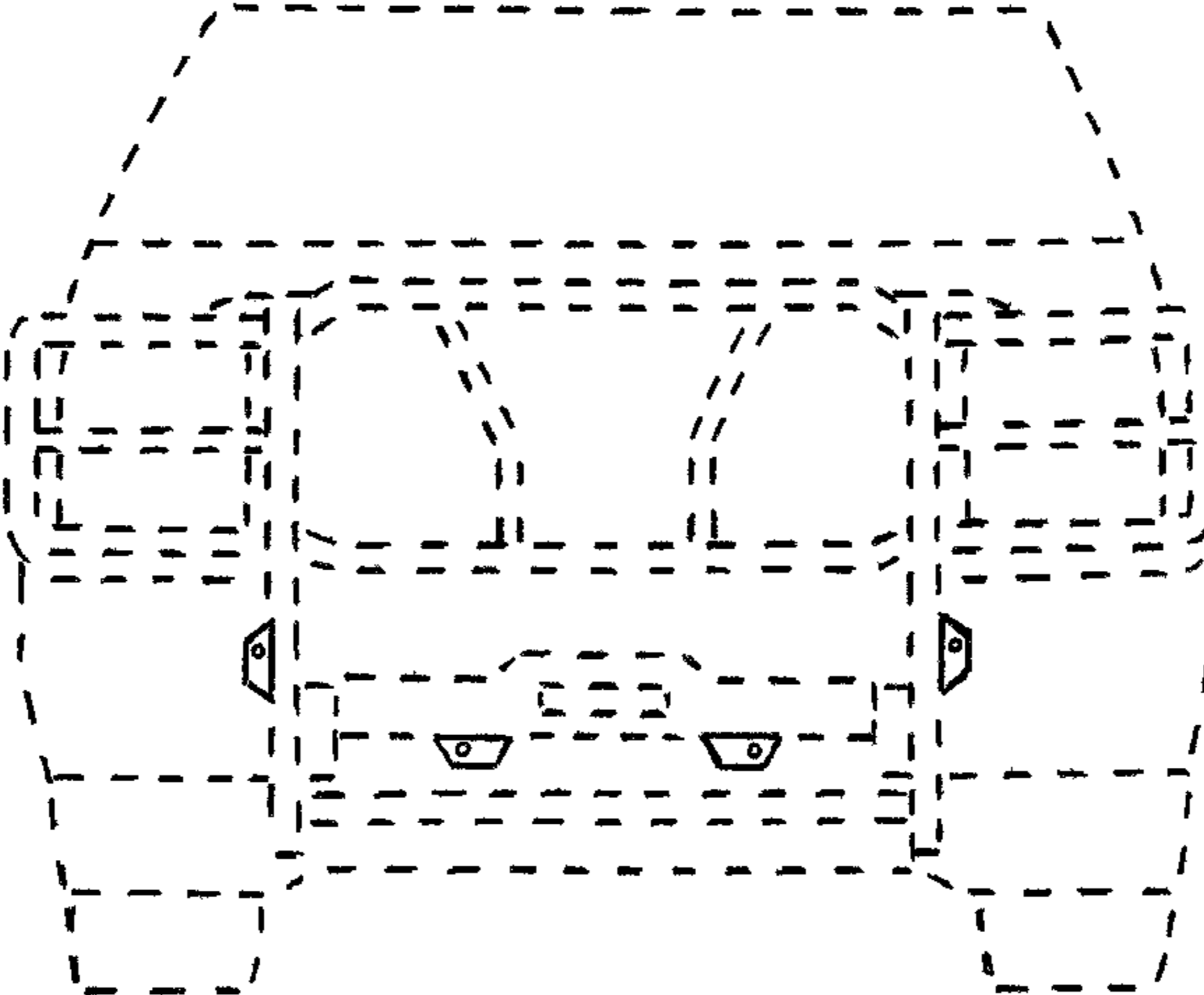

FIG. 10