



US00D744878S

(12) **United States Design Patent**
Yokino et al.

(10) **Patent No.:** **US D744,878 S**
(45) **Date of Patent:** **** Dec. 8, 2015**

(54) **SPECTROMETER**

D603,280 S * 11/2009 Shibayama D10/81
D603,731 S 11/2009 Shibayama

(71) Applicant: **HAMAMATSU PHOTONICS K.K.**,
Hamamatsu-shi, Shizuoka (JP)

(72) Inventors: **Takafumi Yokino**, Hamamatsu (JP);
Katsumi Shibayama, Hamamatsu (JP);
Katsuhiko Kato, Hamamatsu (JP)

(73) Assignee: **HAMAMATSU PHOTONICS K.K.**,
Hamamatsu-shi, Shizuoka (JP)

(**) Term: **14 Years**

(21) Appl. No.: **29/520,575**

(22) Filed: **Mar. 16, 2015**

Related U.S. Application Data

(62) Division of application No. 29/498,395, filed on Aug.
4, 2014, now Pat. No. Des. 733,599.

(30) **Foreign Application Priority Data**

Feb. 4, 2014 (JP) 2014-002259
Feb. 4, 2014 (JP) 2014-002260
Feb. 4, 2014 (JP) 2014-002261
Feb. 4, 2014 (JP) 2014-002262
Feb. 4, 2014 (JP) 2014-002263

(51) **LOC (10) Cl.** **10-04**

(52) **U.S. Cl.**
USPC **D10/75**; D10/46; D10/81

(58) **Field of Classification Search**
USPC D10/46, 75, 81; 250/226; 356/328, 406,
356/454, 456, 512, 326
CPC G01J 3/0291; G01J 3/0259; G01J 3/0256;
G01J 3/0272; G01J 1/02; G01J 1/0204;
G01J 1/0237; G01J 2003/0257; G01J
2003/0261
See application file for complete search history.

(56) **References Cited**

U.S. PATENT DOCUMENTS

7,132,644 B2 11/2006 Grunert et al.

FOREIGN PATENT DOCUMENTS

JP 2013-029325 A 2/2013
JP 2013-029327 A 2/2013
WO WO-2008/149939 A1 12/2008

OTHER PUBLICATIONS

Hamamatsu Photonics K.K., "Website of Hamamatsu Photonics
K.K.," Nov. 5, 2013.
Hamamatsu Photonics K.K., "News release from Hamamatsu
Photonics K.K.," Nov. 5, 2013.

* cited by examiner

Primary Examiner — Antoine D Davis

(74) *Attorney, Agent, or Firm* — Drinker Biddle & Reath
LLP

(57) **CLAIM**

The ornamental design for a spectrometer, as shown and
described.

DESCRIPTION

FIG. 1 is a front view of a spectrometer our new design.
FIG. 2 is a rear view of the spectrometer of FIG. 1.
FIG. 3 is a top plan view of the spectrometer of FIG. 1.
FIG. 4 is a bottom view of the spectrometer of FIG. 1.
FIG. 5 is a right side view of the spectrometer of FIG. 1.
FIG. 6 is a left side view of the spectrometer of FIG. 1.
FIG. 7 is a top perspective of the spectrometer of FIG. 1.
FIG. 8 is a bottom perspective of the spectrometer of FIG. 1;
and,
FIG. 9 is a reference view of the spectrometer of FIG. 1 in use,
wherein the spectrometer is connected to a printed circuit
board in a printer.
The features shown in dotted lines depict environmental sub-
ject matter only and form no part of the claimed design.

1 Claim, 9 Drawing Sheets

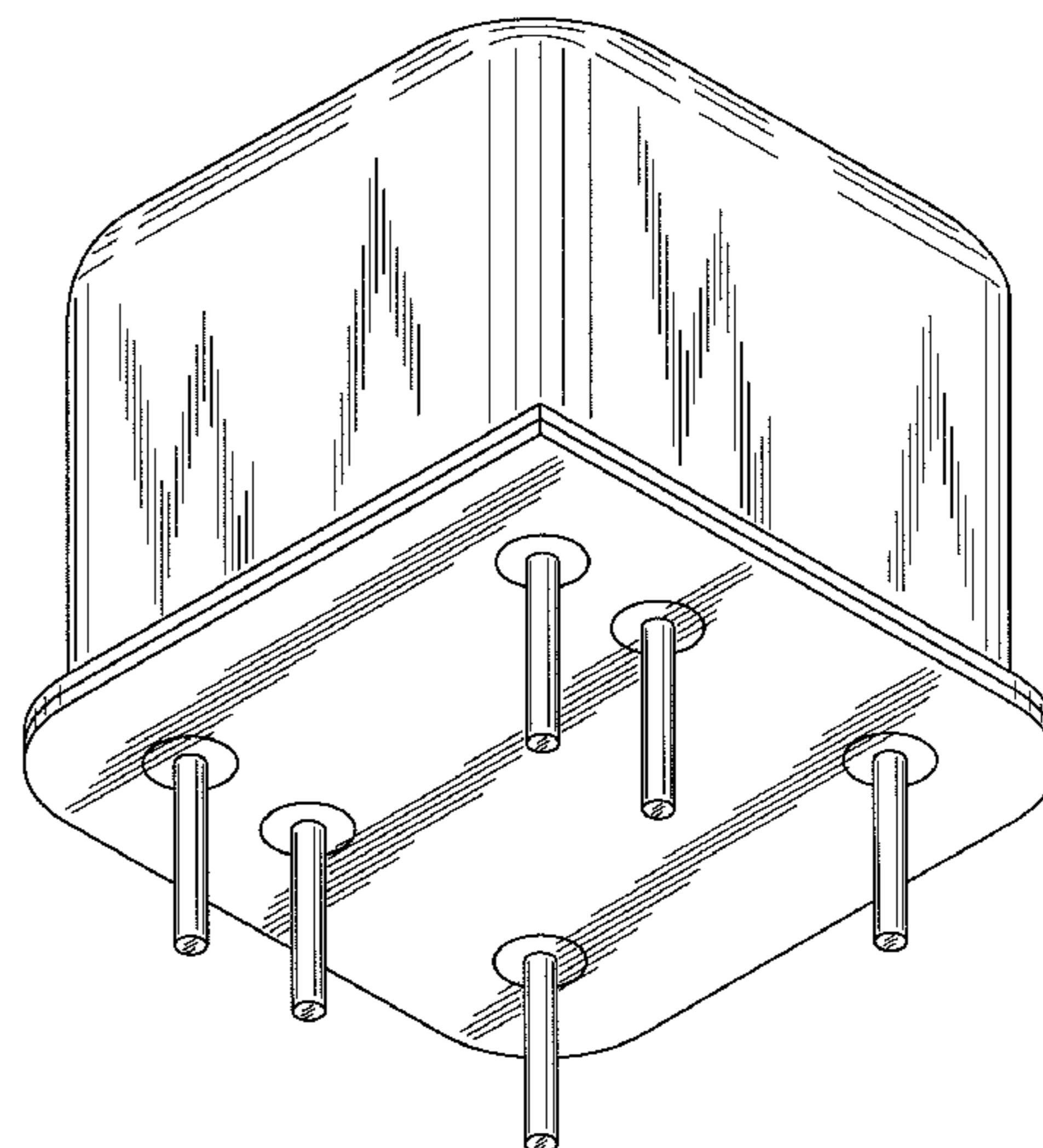
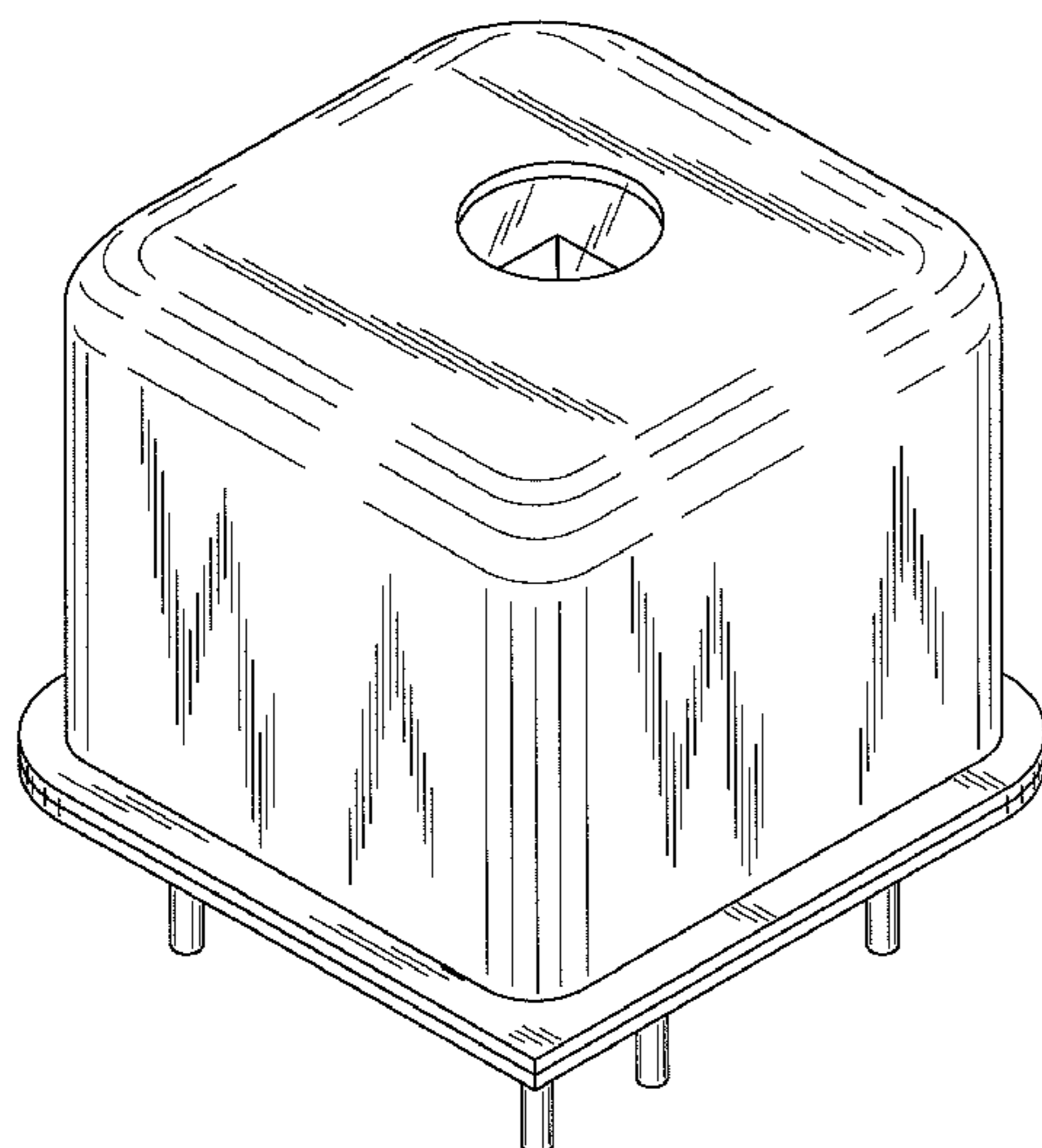

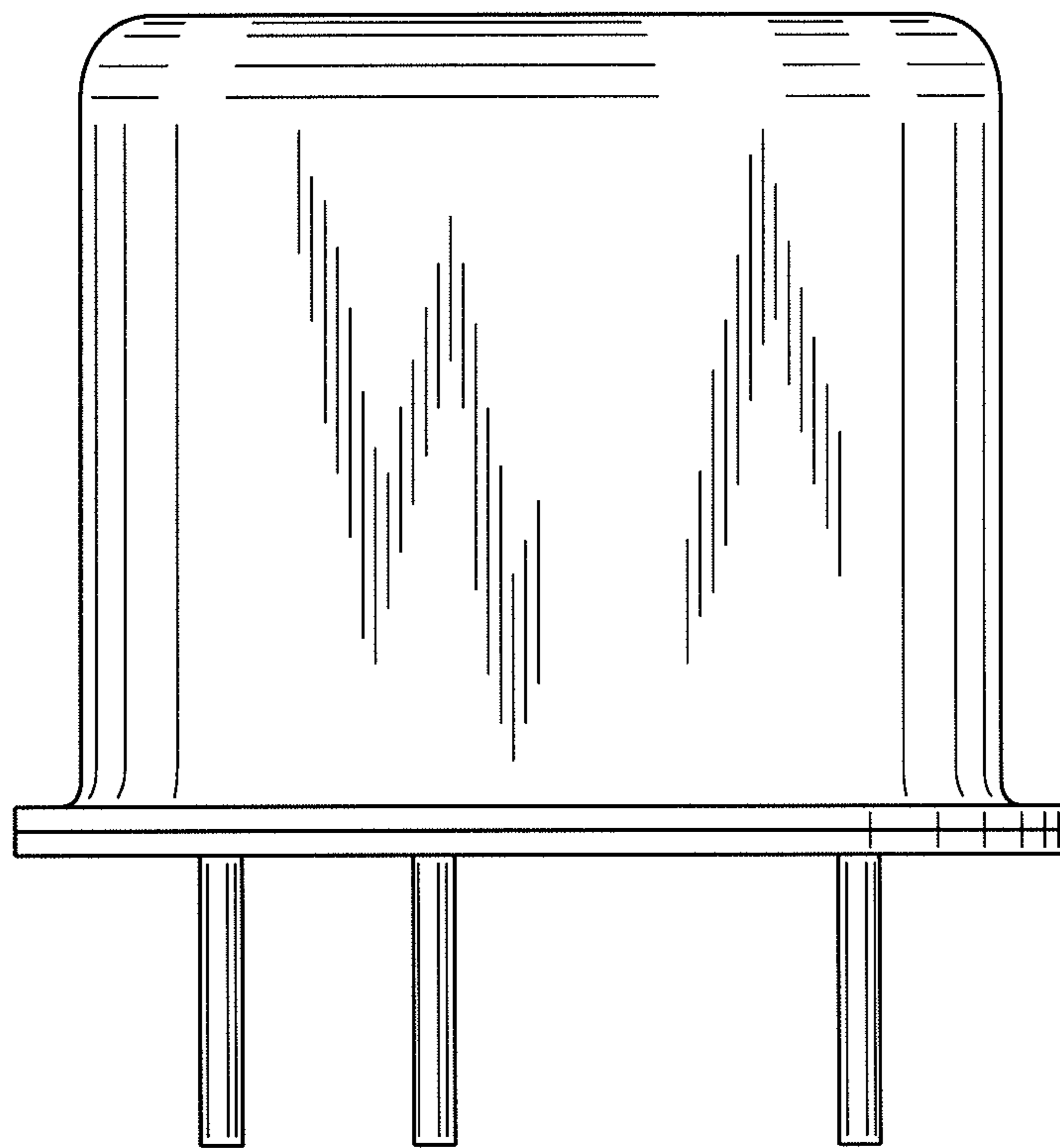

FIG. 1

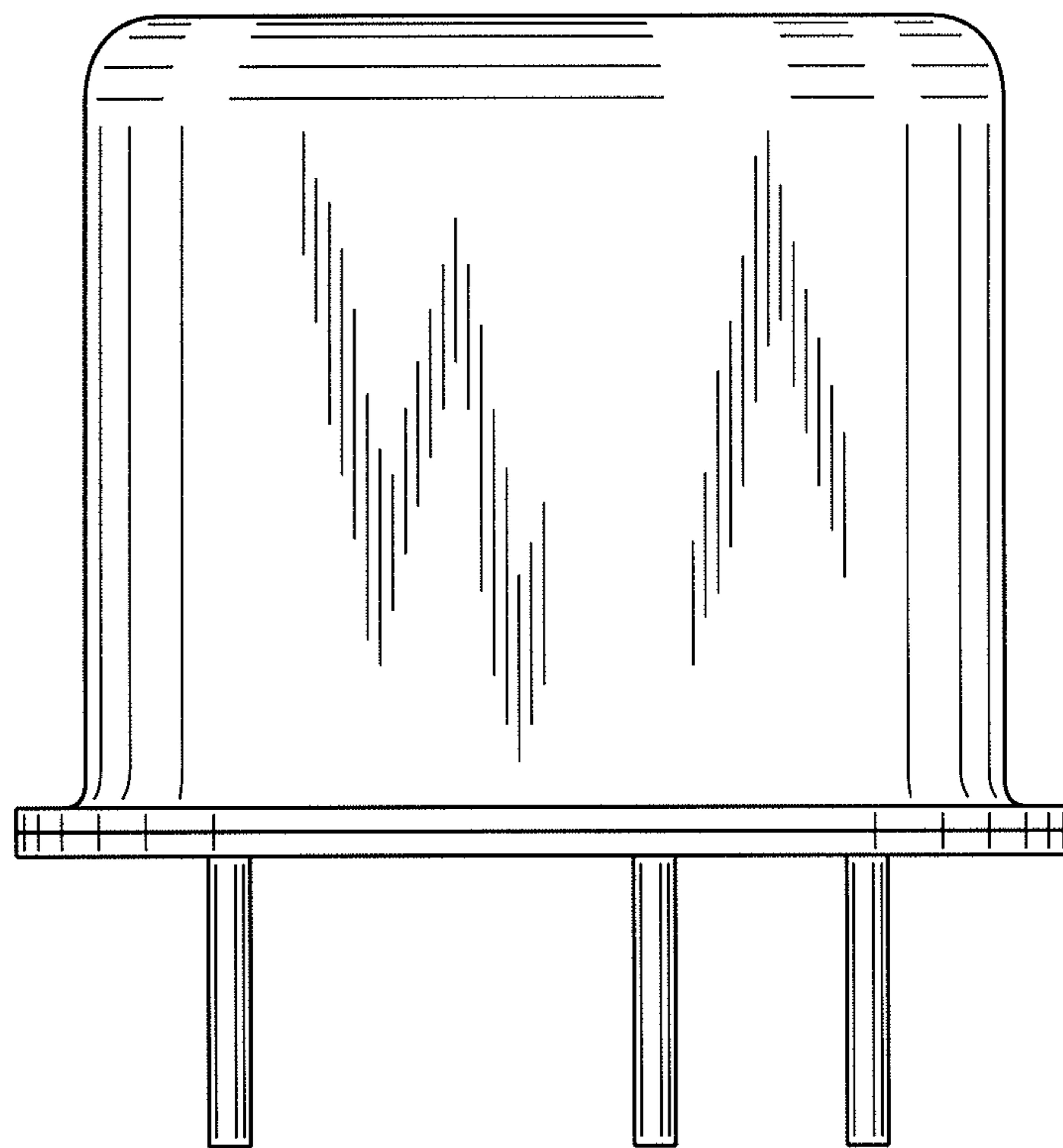

FIG. 2

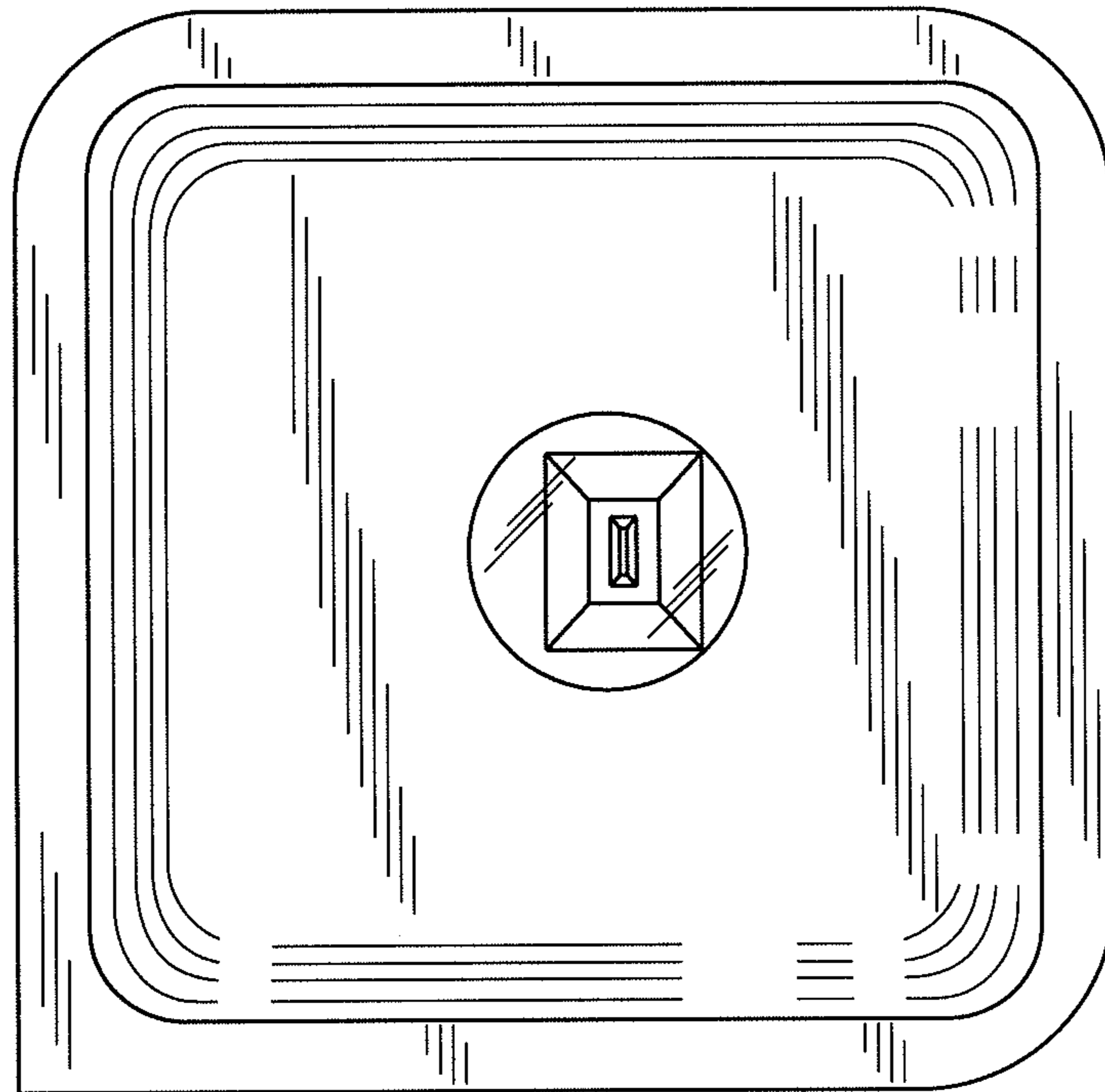

FIG. 3

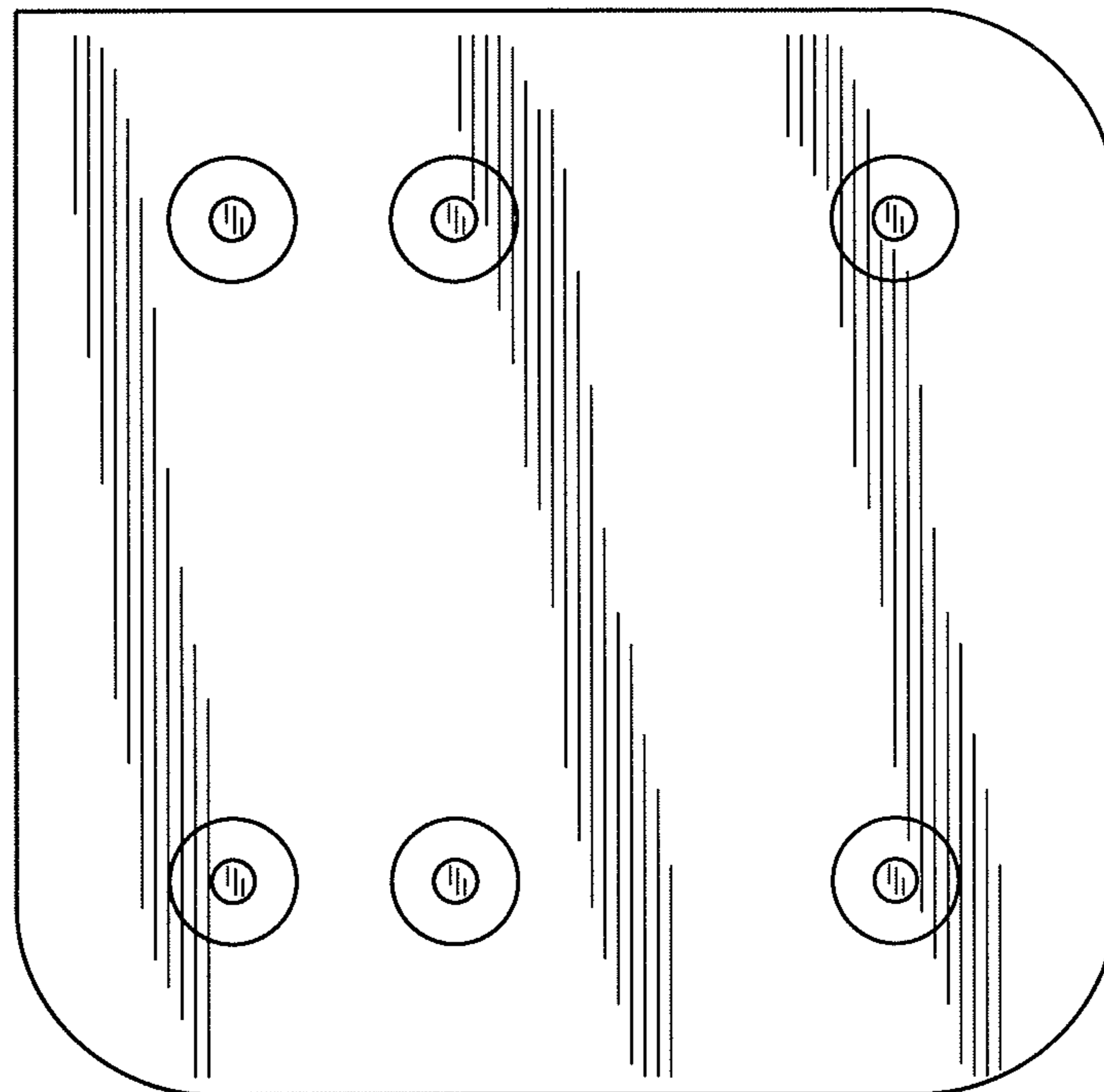

FIG. 4

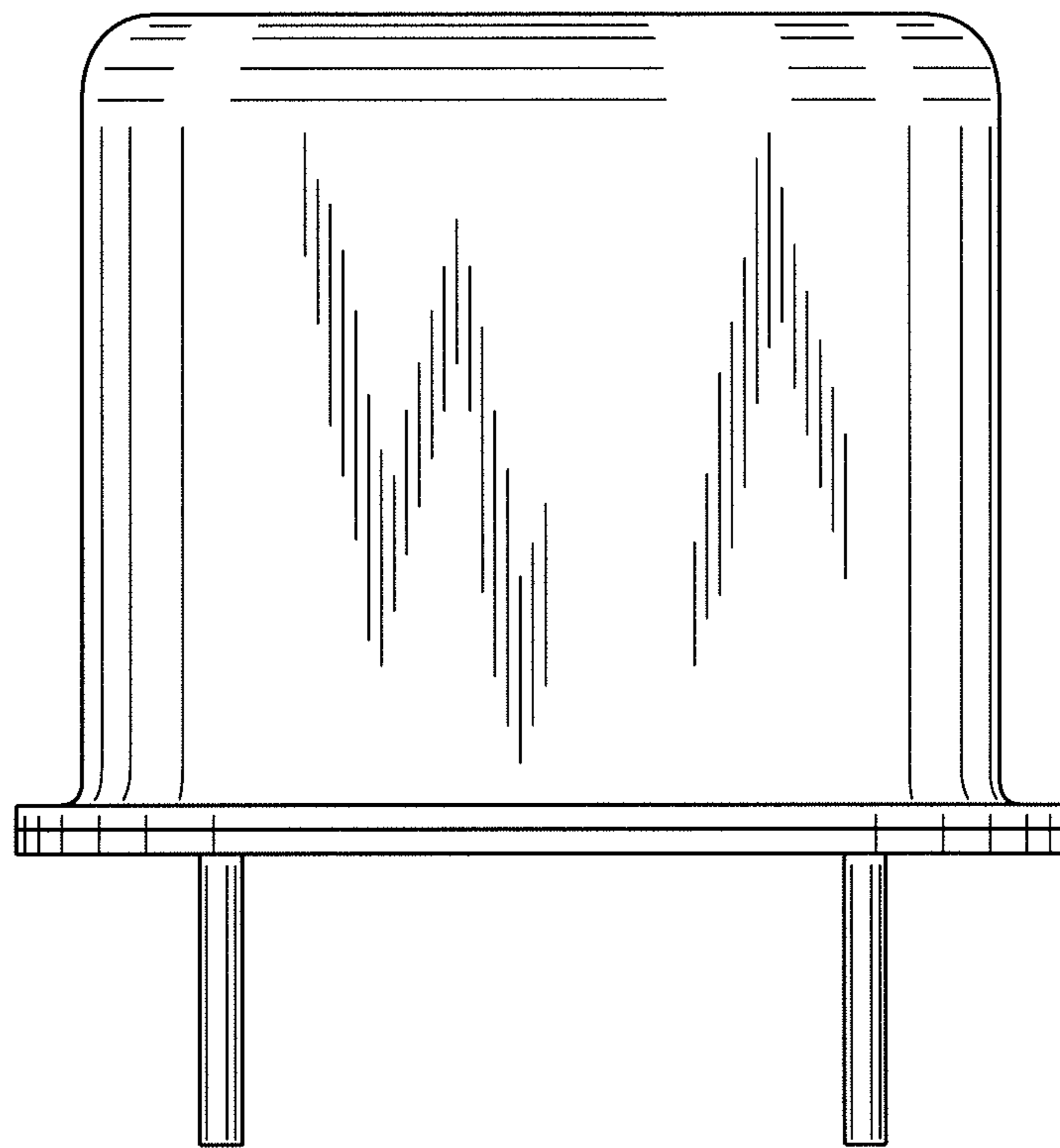

FIG. 5

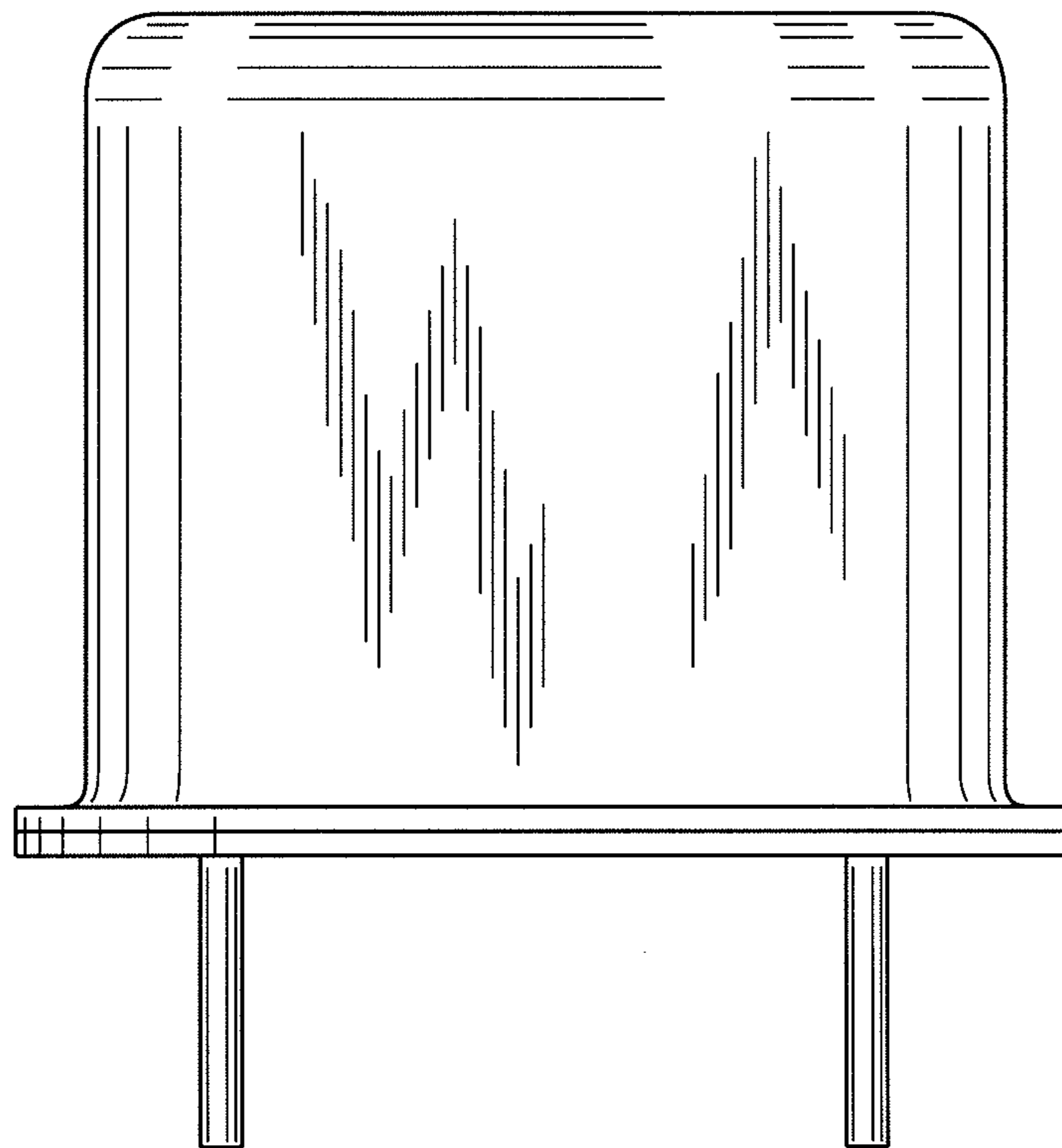

FIG. 6

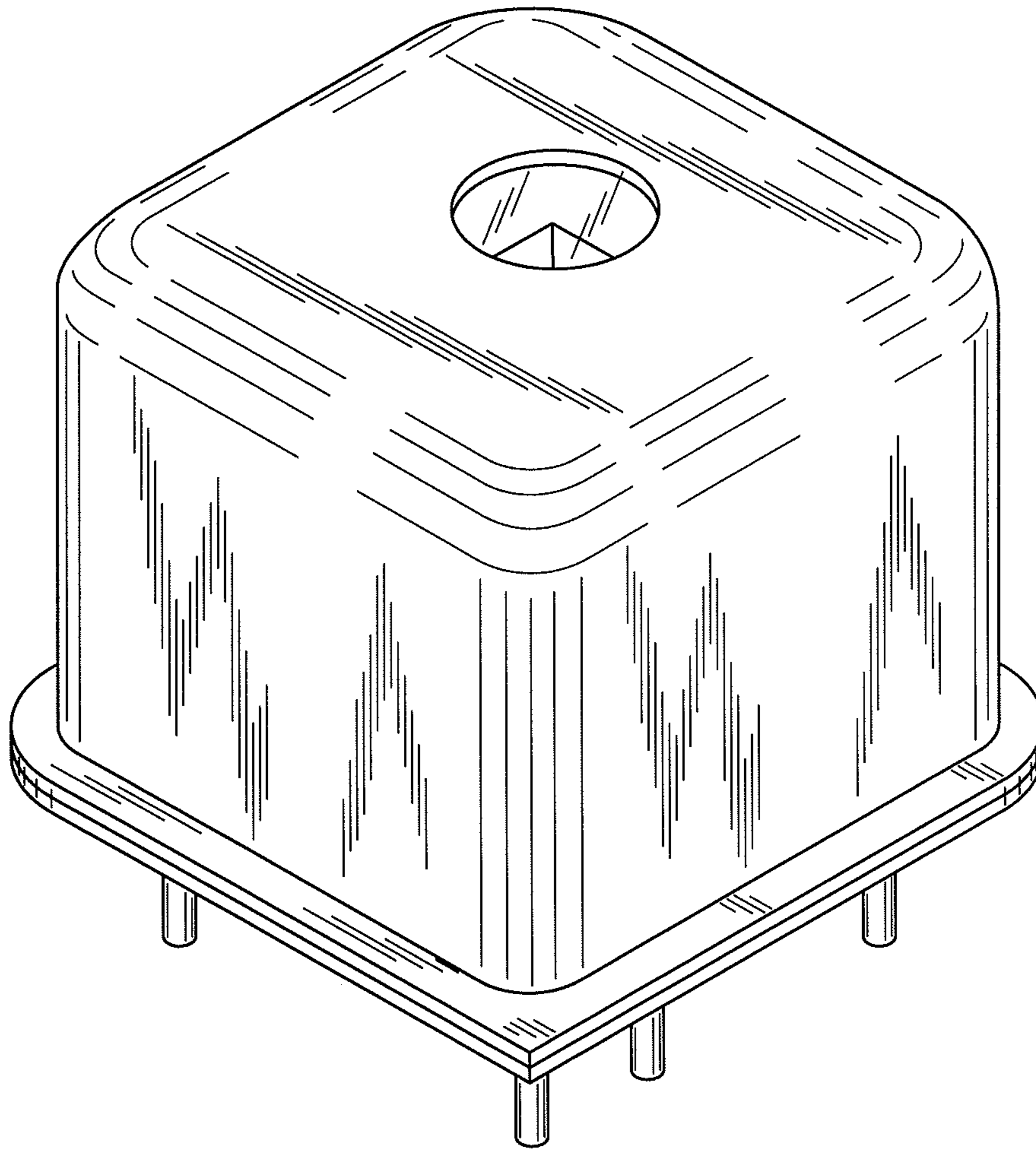

FIG. 7

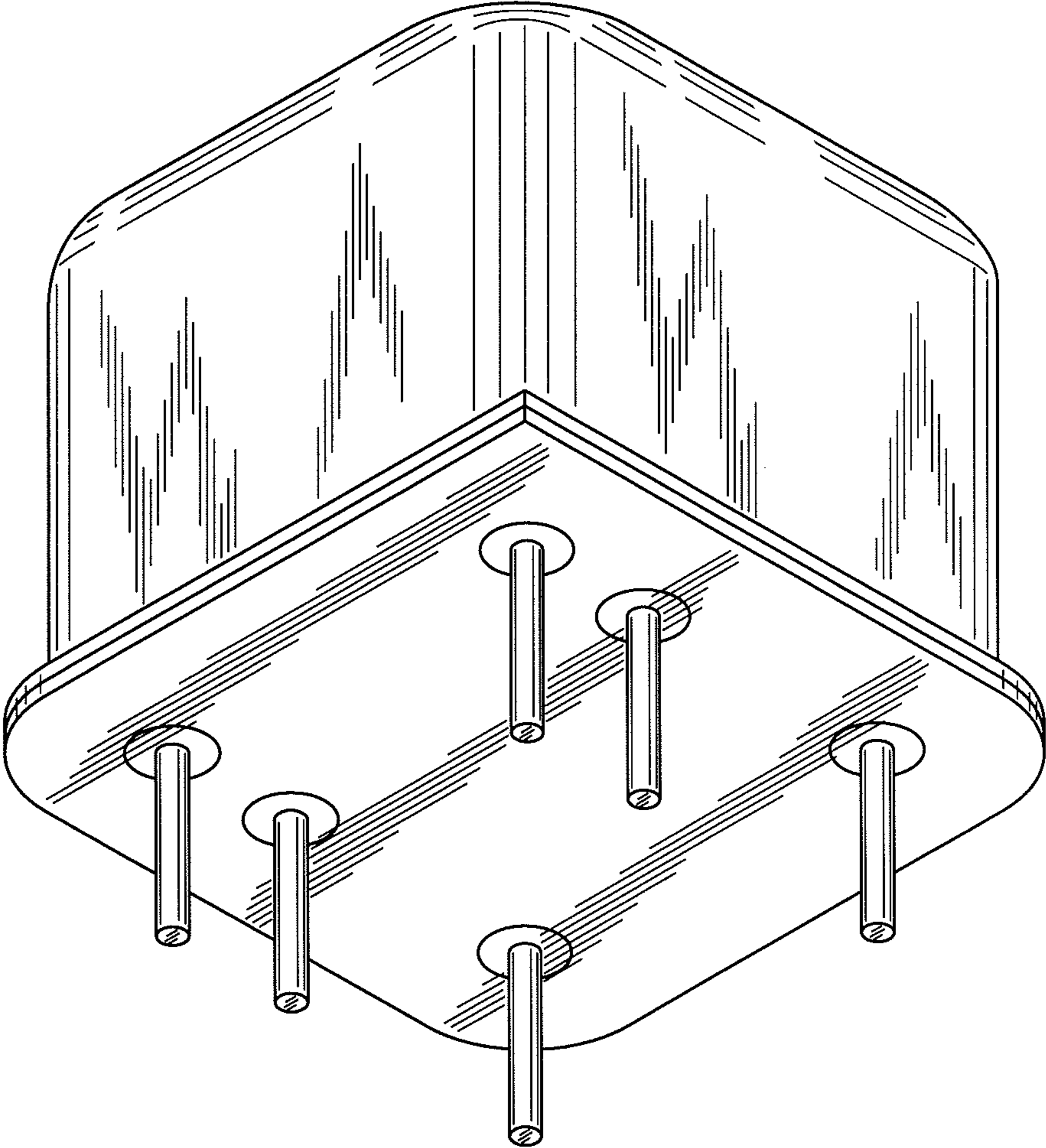

FIG. 8

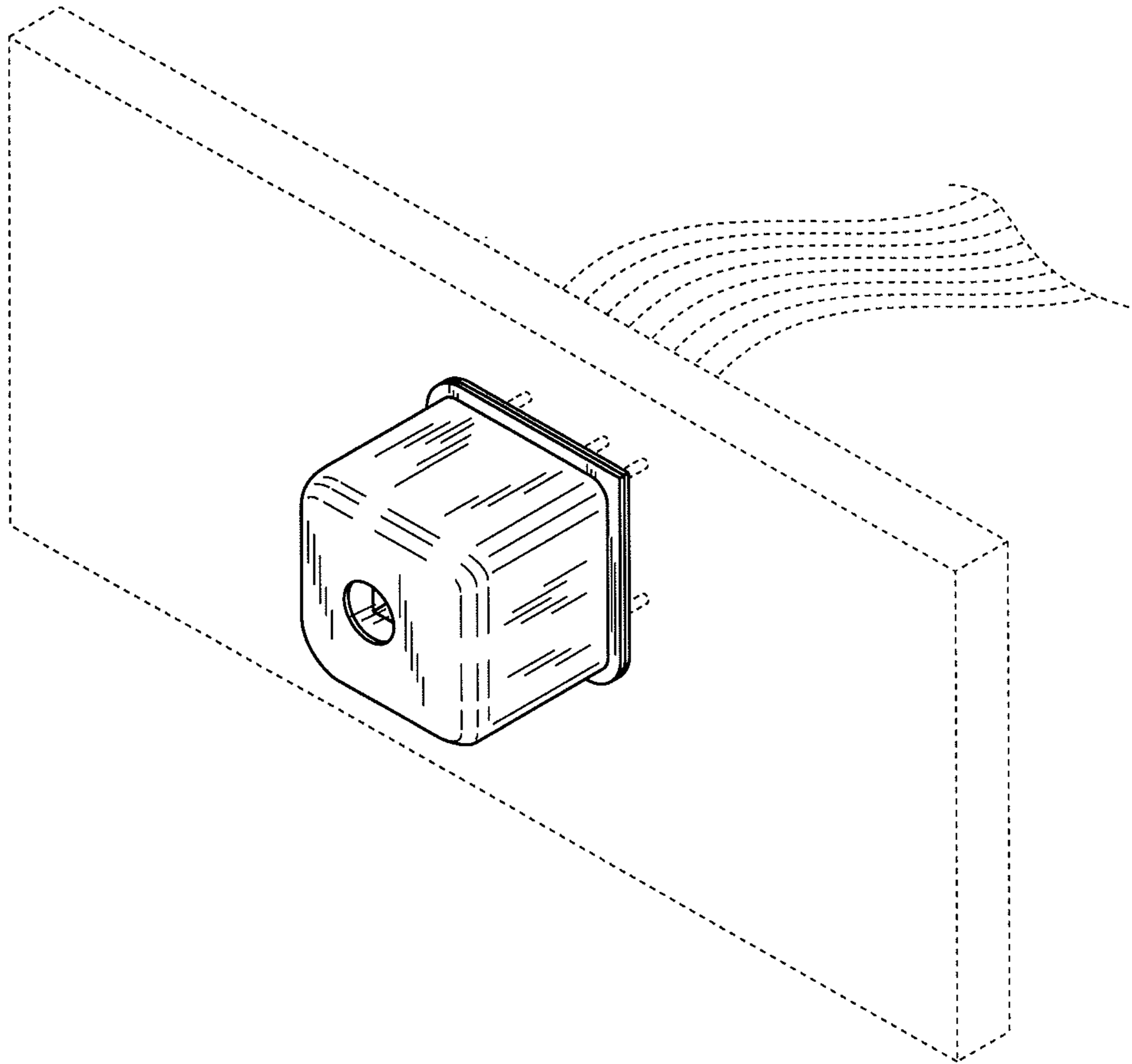

FIG. 9